

# PARTS LIST

## BRUSHCUTTERS

**BKZ4500DL**  
**BKZ5000DL**

**NOTE :**

1. Use ZENOAH genuine parts as specified in the parts list for repair and/or replacement.
2. ZENOAH does not warrant the machines, which have been damaged by the use of any parts other than those specified by the company.
3. When placing parts orders for repair and/or replacement, check if the model name and the serial number are applicable to those specified in the parts list, then use parts number described in the parts list.
4. The contents described in the parts list are accurate as of the date and may change due to improvement.
5. The parts for the machine shall be supplied ten (10) years after the machine is discontinued. [It is possible that some specific parts may be subject to change of their delivery term and list price within the limit of ten (10) years after the machine is discontinued. It is also possible that some parts may be available even after the limit of ten (10) years.]

**APPLICABLE SERIAL NUMBERS:**

September 2007

BKZ4500DL :	DRIVE UNIT	60502023	and up
	ENGINE UNIT	61102058	and up
BKZ5000DL :	DRIVE UNIT	60204904	and up
	ENGINE UNIT	61106020	and up

Fig.1 CUTTER GROUP

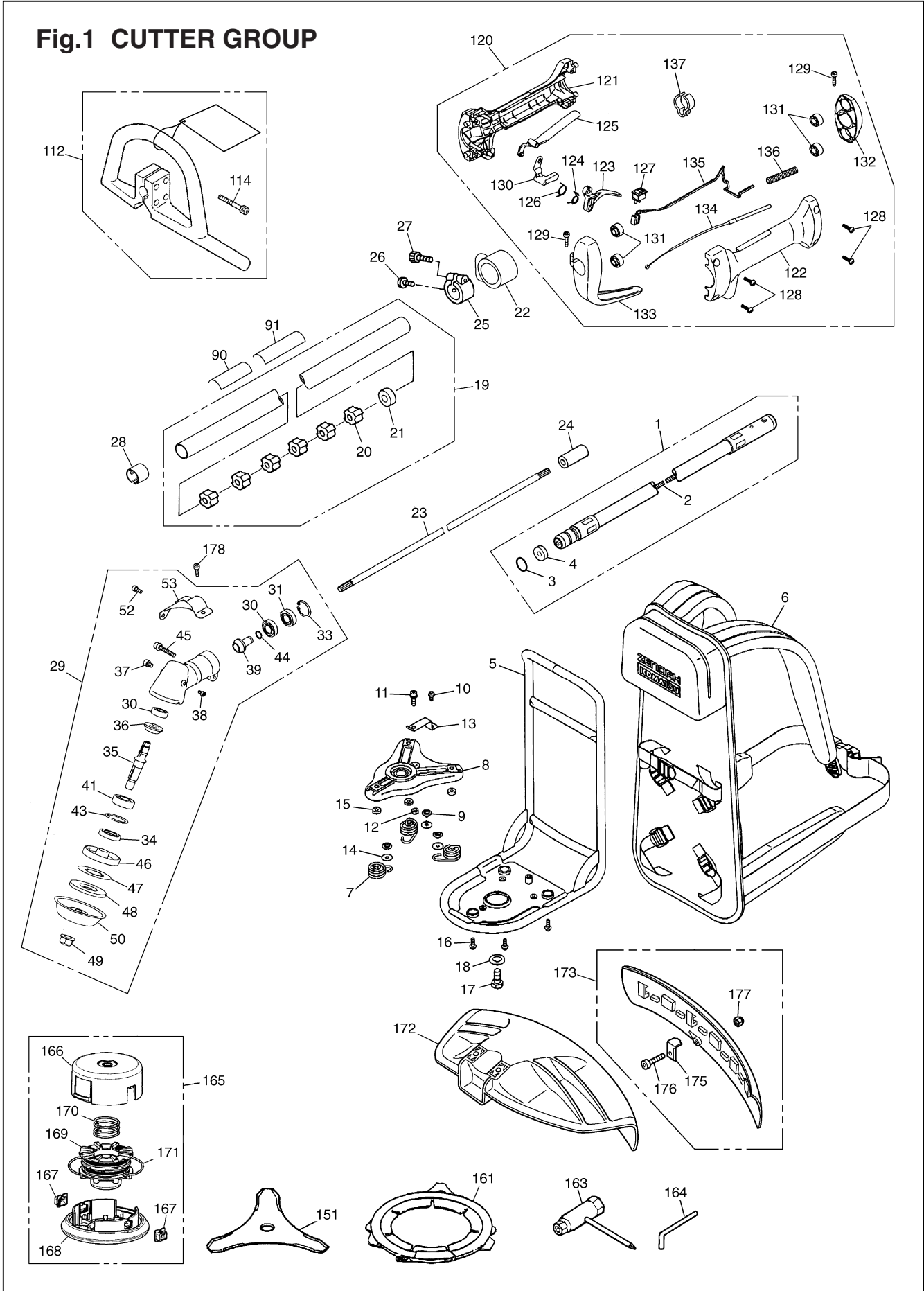

Fig.1 CUTTER GROUP

Key#	PART NUMBER	DESCRIPTION	Q'TY /UNIT	NOTE	Key#	PART NUMBER	DESCRIPTION	Q'TY /UNIT	NOTE
1	848KH05912	SHAFT FLEX ASSY	1		112	848KH03200	HANDLE ASSY	1	
2	848KH059G1	• SHAFT-FLEX	1						
3	07000-12018	• O-RING	1		114	T4950-53040	• SCREW	4	
4	848KH059K0	• SEAL	1						
5	848H7135A1	FRAME	1		120	8488R40083	GRIP ASSY	1	
6	T1141-37100	BACK CSHN ASSY	1		121	848JL233A5	• BODY-R	1	
7	848H7137A0	SPRING	3		122	848JL233B5	• BODY-L	1	
8	848H7137C0	PLATE, ENGINE	1		123	848JL233C6	• LEVER	1	
9	8488050800	BOLT	3		124	848JL233D3	• SPRING	1	
10	8488151002	BOLT TORX M5xL10 T27	1		125	848JL233E2	• LEVER-S	1	
11	T4950-62040	BOLT TORX	1		126	848JL233F3	• SPRING	1	
12	0280-10605	NUT M6xP1.0	1		127	T4506-52110	• SWITCH	1	
13	848H7137E0	STOPPER	1		128	8488251601	• SCREW TP5(P-tight)xL16 T27	4	
14	8488705010	WASHER	3		129	4820-13180	• BOLT TORX M5xL20 T27	2	
15	8488Y54010	SPACER	3		130	848JL233G2	• LEVER	1	
16	4820-85510	BOLT TORX M5xL16 T27	3		131	848JL233H3	• ABSORBER	4	
17	01010-81025	BOLT	1		132	8488RB0080	• HOLDER REAR	1	
18	01642-21016	WASHER	1		133	8488RA0081	• HOLDER FRONT	1	
19	848KD35820	PIPE COMP.	1		134	8488PA0062	• CABLE COMP.	1	
20	3180-11321	• BUSHING	6		135	8488M10020	• CORD COMP.	2	
21	6129-12120	• BEARING COMP.	1		136	8488H28501	• TUBE	1	
22	T3000-14810	COVER	1		137	848BC059M0	• CLAMP	3	
23	6129-12210	SHAFT	1						
24	6129-12220	SHAFT, joint	1		151	8488Z23010	BLADE	1	
25	6129-12230	CLAMP	1						
26	8488051000	SCREW	1		161	848JL092B1	COVER BLADE	1	
27	T4950-52001	BOLT	1						
28	6359-13910	SPACER	1		163	T4017-91130	SOCKET	1	
29	848KH06100	GEARCASE ASSY	1		164	3540-91110	BAR	1	
30	06000-06000	• BEARING	2		165	848JL06911	TAPHEAD ASSY	1	
31	06001-06000	• BEARING	1		166	848JL069M1	• CASE	1	
					167	T3189-15191	• EYELET	2	
33	04065-02612	• RING	1		168	T3189-15132	• COVER	1	
34	8488AL3500	• SEAL	1		169	T3189-15142	• CORD HOLDER	1	
35	848JL061B4	• SHAFT	1		170	T3189-15160	• SPRING	1	
36	848JL061C2	• GEAR	1		171	T3189-15180	• CORD	1	
37	T4950-60800	• BOLT TORX M6xL8 T27	1		172	848JL066A4	GUARD	1	
38	T4950-40800	• BOLT TORX M4xL8 T27	1		173	848JL06634	GURD ASSY	1	
39	848KH061D0	• PINION	1						
					175	848JL066B2	• BLADE	1	
41	06004-06202	• BEARING	1		176	4820-72150	• BOLT TORX M4xL16 T27	1	
					177	3238-13150	• NUT	1	
43	04065-03515	• RING, SNAP	1		178	T4950-63040	BOLT TORX M6xL30 T27	2	
44	3180-13330	• RING	1						
45	T4950-63540	• BOLT TORX	1						
46	848JL061F3	• HOLDER (A)	1						
47	848JL061L2	• PLATE	1						
48	848JL061G2	• HOLDER (B)	1						
49	848JL061K1	• NUT M12xP1.25	1						
50	848KH061J0	• COVER	1						
52	T4950-51200	• BOLT TORX M5xL12 T27	1						
53	848JL066C2	• PLATE	1						
90	848KF090R0	PLATE NAME	1						
91	6425-12552	PLATE	1						

Fig.2 ENGINE GROUP

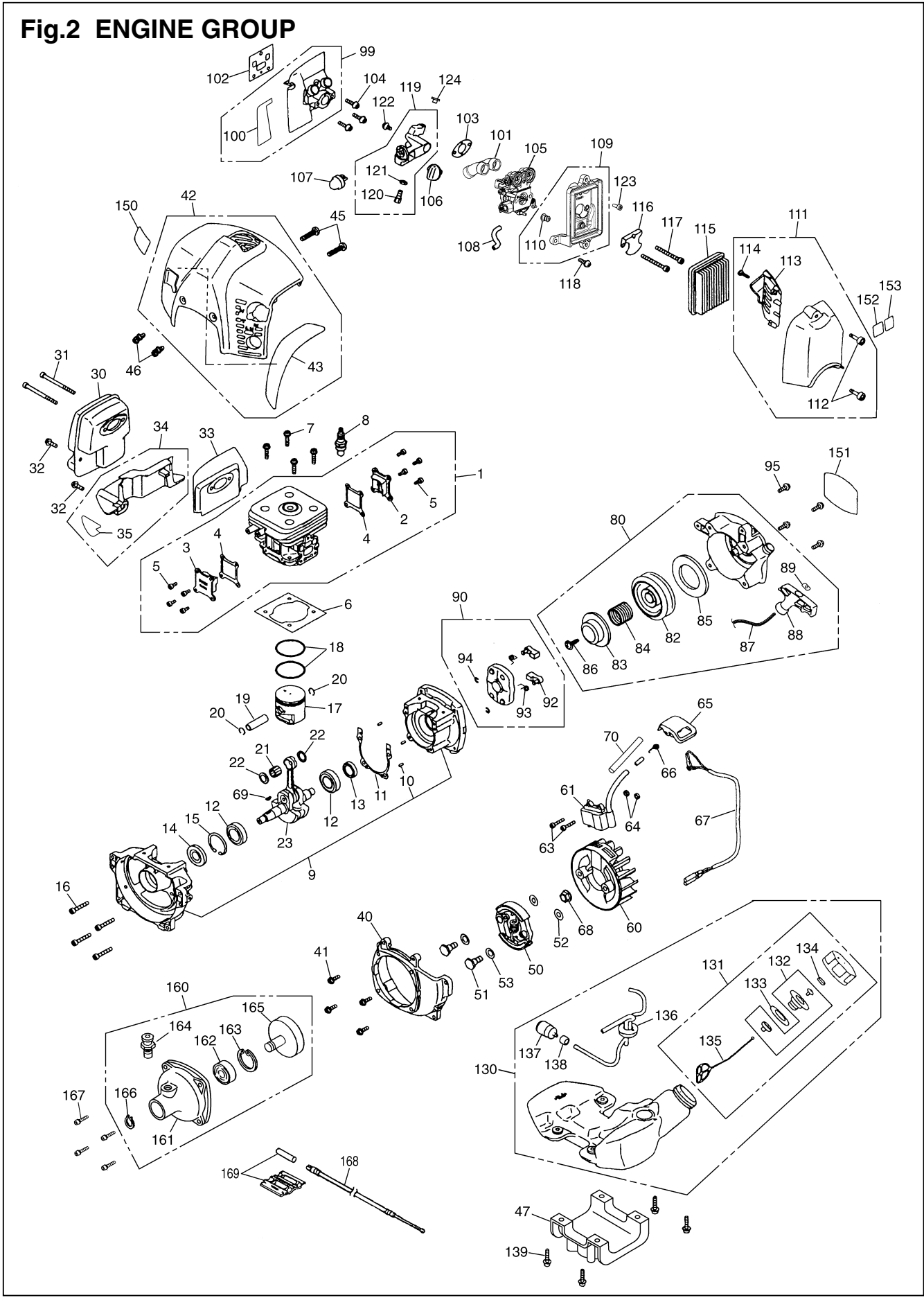
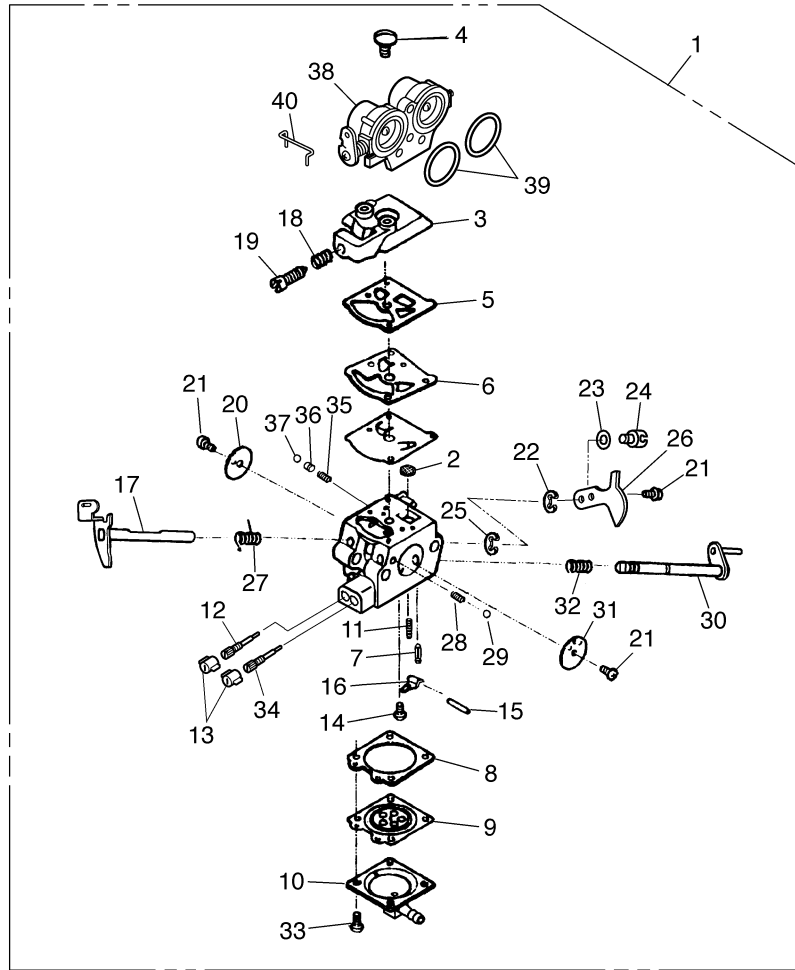

Fig.2 ENGINE GROUP

Key#	PART NUMBER	DESCRIPTION	Q'TY /UNIT	NOTE	Key#	PART NUMBER	DESCRIPTION	Q'TY /UNIT	NOTE
1	848GD01211	CYLINDER COMP.	1		90	848H707521	PULLEY ASSY	1	
2	848GD012C1	• COVER, TR, S	1		92	848H7075R1	• RATCHET	2	
3	848GD012D1	• COVER, TR, F	1		93	848H7075S0	• SPRING	2	
4	848H7012E1	• GASKET, TR	2		94	1034-72180	• E RING	2	
5	4820-16310	• BOLT TORX M4xL10 T27	8		95	4820-32120	BOLT TORX	4	
6	848H7012B1	GASKET	1		99	848H711400	INSULATOR ASSY	1	
7	4820-12130	BOLT TORX M5xL22 T27	4		100	848H7114F0	• TAPE	1	
8	3699-91867	SPARK PLUG	1	CMR7H	101	848H7082A2	PIPE	1	
9	848H702111	CRANKCASE COMP.	1		102	848H7014B2	GASKET	1	
10	2629-21130	• PIN	3		103	848H7014C1	GASKET, CARB	1	
11	T1400-21140	GASKET, CASE	1		104	T4950-52021	BOLT TORX M5xL20 T27	3	
12	84889F3511	BEARING	2		105	848H708103	CARBURETOR ASSY	1	
13	T4019-21210	SEAL	1		106	848H7082F0	KNOB	1	
14	1400-21220	SEAL	1		107	2850-81900	PUMP	1	
15	04065-03515	RING, SNAP	1		108	8488F40450	TUBE	1	
16	4820-21310	BOLT TORX M5xL30 T27	4		109	848GG08310	BODY ASSY	1	
17	848GD041A2	PISTON	1		110	848GG083D0	• GROMMET	1	
18	2670-41211	RING	2		111	848H708321	COVER ASSY	1	
19	2880-41310	PIN	1		112	8488052011	• SCREW	2	
20	3350-41320	SNAP RING	2		113	848H7083Y0	• GUARD	1	
21	1400-41410	BEARING	1		114	8488241600	• SCREW	1	
22	2670-41510	WASHER	2		115	848H7083F1	ELEMENT	1	
23	848H704201	CRANKSHAFT COMP.	1		116	T4012-82510	PLATE	1	
30	848H7115A1	MUFFLER	1		117	4820-15310	BOLT TORX M5xL50 T27	2	
31	8488156700	BOLT TORX M5xL67 T27	2		118	4820-85510	BOLT TORX M5xL16 T27	1	
32	4820-85510	BOLT TORX M5xL16 T27	2		119	848H718222	BRACKET ASSY	1	
33	848H7015C1	GASKET	1		120	T1610-13170	• SCREW	1	
34	848H711530	PLATE	1		121	0282-10604	• NUT	1	
35	848H7115F0	• TAPE	1		122	8488251601	SCREW M5xL16 T27	1	
40	848H7053A2	COVER	1		123	8488141200	BOLT M4x12 T27	1	
41	4820-85510	BOLT TORX M5xL16 T27	4		124	848GG082L1	STOPPER	1	
42	848H713110	COVER-TOP ASSY	1		130	848H718501	TANK ASSY	1	
43	848H7131E0	• TAPE	1		131	T1015-85202	• CAP ASSY	1	
45	T4970-52000	SCREW TORX 5xL20	2		132	4500-85300	•• HOLDER ASSY	1	
46	8488151002	BOLT TORX M5xL10 T27	2		133	4500-85220	•• PACKING	1	
47	848H7137D0	BRACKET	1		134	5601-85260	•• FILTER	1	
50	848H705110	SHOE COMP.	1		135	4820-85260	•• STOPPER	1	
51	1200-51211	SCREW	2		136	848H718530	• PIPE COMP.	1	
52	1200-51230	WASHER	2		137	3302-85400	• FILTER	1	
53	1200-51241	WASHER	2		138	2841-31280	• COLLER	1	
60	848H7471A0	ROTOR	1		139	T4950-53040	BOLT	4	
61	848H707122	COIL ASSY	1		150	848H7090B1	LABEL, COVER	1	
63	T4950-42200	BOLT TORX M4xL22 T27	2		151	848GD190C1	LABEL, RECOIL	1	
64	1260-71261	SPACER	2		152	2634-31420	LABEL (CE)	1	
65	T1400-72110	CAP	1		153	8488X01180	LABEL	1	
66	1900-72120	SPRING	1		160	6129-11100	HOUSING ASSY	1	
67	T1400-73200	CORD COMP.	1		161	6129-11110	• HOUSING	1	
68	1400-43230	NUT	1		162	06002-06001	• BEARING	1	
69	1000-43240	KEY	1		163	04065-02812	• RING	1	
70	2850-71320	TUBE	1		164	848EEN5321	• STOPPER COMP.	1	
80	848H707511	RECOIL ASSY	1		165	6278-12311	• DRUM	1	
82	848H7075C0	• REEL	1		166	04064-01210	• SNAP RING	1	
83	848H7075L1	• PLATE, CAM	1		167	T4950-62040	BOLT TORX M6xL20 T27	4	
84	848H7075K1	• SPRING, DAMPER	1		168	8488P40330	CABLE COMP.	1	
85	848H7075B1	• SPRING, SPIRAL	1		169	T1000-83300	JOINT ASSY	1	
86	848H7075E1	• SCREW	1						
87	848H7075F1	• ROPE	1						
88	848H7075J1	• KNOB	1						
89	848H7075G1	• STOPPER	1						

**Fig.3 CARBURETOR**



Key#	PART NUMBER	DESCRIPTION	Q'TY /UNIT	NOTE	Key#	PART NUMBER	DESCRIPTION	Q'TY /UNIT	NOTE
1	848H708103	CARBURETOR ASSY	1		24	1751-81141	• SWIVEL	1	
2	3306-81380	• SCREEN	1		25	1148-81390	• RING	1	
3	848H7081H0	• COVER	1		26	848H7181Z1	• LEVER, throttle	1	
4	848H7081P0	• SCREW	1		27	2670-81410	• SPRING	1	
5	3304-81140	• GASKET	1		28	3350-81350	• SPRING	1	
6	1172-81150	• DIAPHRAGM	1		29	3350-81220	• BALL	1	
7	3356-81310	• VALVE	1		30	848H7181E0	• SHAFT ASSY, choke	1	
8	2850-81290	• GASKET	1		31	848H7180C0	• VALVE	1	
9	3310-81260	• DIAPHRAGM	1		32	3350-81391	• SPRING	1	
10	848H7081G0	• COVER	1		33	3310-81351	• SCREW	4	
11	1488-81370	• SPRING	1		34	848H7181B0	• NEEDLE	1	
12	2812-81330	• NEEDLE	1		35	2810-81530	• SPRING	1	
13	3415-81490	• CAP	2		36	2812-81510	• PISTON	1	
14	3310-81240	• SCREW	1		37	2812-81520	• BALL	1	
15	3310-81250	• PIN	1		38	848H708200	• BODY ASSY, air valve	1	
16	3310-81230	• LEVER	1		39	848H7082A0	• RING, packing	2	
17	848H7081T1	• SHAFT	1		40	848H7082B0	• LINK ROD	1	
18	1282-81460	• SPRING	1						
19	1145-81540	• SCREW	1						
20	848H7081U1	• VALVE	1						
21	2880-81470	• SCREW	3						
22	1751-81130	• RING	1						
23	1751-81190	• WASHER	1						



Fig.4 CUTTER GROUP

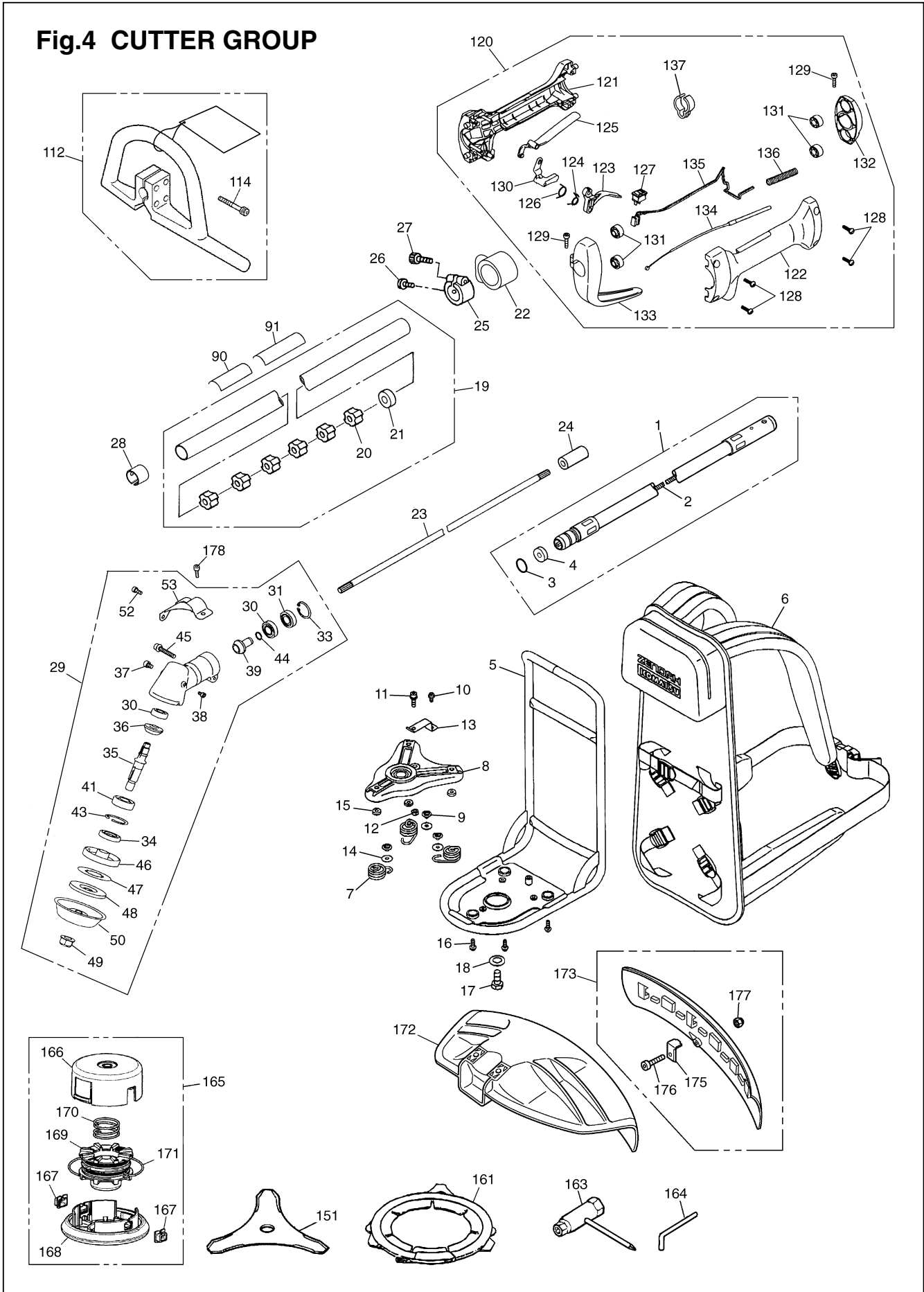



Fig.4 CUTTER GROUP

Key#	PART NUMBER	DESCRIPTION	Q'TY /UNIT	NOTE	Key#	PART NUMBER	DESCRIPTION	Q'TY /UNIT	NOTE
1	848KH05912	SHAFT FLEX ASSY	1		112	848KH03200	HANDLE ASSY	1	
2	848KH059G1	• SHAFT-FLEX	1						
3	07000-12018	• O-RING	1		114	T4950-53040	• SCREW	4	
4	848KH059K0	• SEAL	1						
5	848H7135A1	FRAME	1		120	8488R40083	GRIP ASSY	1	
6	T1141-37100	BACK CSHN ASSY	1		121	848JL233A5	• BODY-R	1	
7	848H7137A0	SPRING	3		122	848JL233B5	• BODY-L	1	
8	848H7137C0	PLATE, ENGINE	1		123	848JL233C6	• LEVER	1	
9	8488050800	BOLT	3		124	848JL233D3	• SPRING	1	
10	8488151002	BOLT TORX M5xL10 T27	1		125	848JL233E2	• LEVER-S	1	
11	T4950-62040	BOLT TORX	1		126	848JL233F3	• SPRING	1	
12	0280-10605	NUT M6xP1.0	1		127	T4506-52110	• SWITCH	1	
13	848H7137E0	STOPPER	1		128	8488251601	• SCREW TP5(P-tight)xL16 T27	4	
14	8488705010	WASHER	3		129	4820-13180	• BOLT TORX M5xL20 T27	2	
15	8488Y54010	SPACER	3		130	848JL233G2	• LEVER	1	
16	4820-85510	BOLT TORX M5xL16 T27	3		131	848JL233H3	• ABSORBER	4	
17	01010-81025	BOLT	1		132	8488RB0080	• HOLDER REAR		
18	01642-21016	WASHER	1		133	8488RA0081	• HOLDER FRONT	1	
19	848KD35820	PIPE COMP.	1		134	8488PA0062	• CABLE COMP.	1	
20	3180-11321	• BUSHING	6		135	8488M10020	• CORD COMP.	2	
21	6129-12120	• BEARING COMP.	1		136	8488H28501	• TUBE	1	
22	T3000-14810	COVER	1		137	848BC059M0	• CLAMP	1	
23	6129-12210	SHAFT	1						
24	6129-12220	SHAFT, joint	1		151	8488Z23010	BLADE	1	
25	6129-12230	CLAMP	1						
26	8488051000	SCREW	1		161	848JL092B1	COVER BLADE	1	
27	T4950-52001	BOLT	1						
28	6359-13910	SPACER	1		163	T4017-91130	SOCKET	1	
29	848KH06100	GEARCASE ASSY	1		164	3540-91110	BAR	1	
30	06000-06000	• BEARING	2		165	848JL06911	TAPHEAD ASSY	1	
31	06001-06000	• BEARING	1		166	848JL069M1	• CASE	1	
					167	T3189-15191	• EYELET	2	
33	04065-02612	• RING	1		168	T3189-15132	• COVER	1	
34	8488AL3500	• SEAL	1		169	T3189-15142	• CORD HOLDER	1	
35	848JL061B4	• SHAFT	1		170	T3189-15160	• SPRING	1	
36	848JL061C2	• GEAR	1		171	T3189-15180	• CORD	1	
37	T4950-60800	• BOLT TORX M6xL8 T27	1		172	848JL066A4	GUARD	1	
38	T4950-40800	• BOLT TORX M4xL8 T27	1		173	848JL06634	GURD ASSY	1	
39	848KH061D0	• PINION	1						
					175	848JL066B2	• BLADE	1	
41	06004-06202	• BEARING	1		176	4820-72150	• BOLT TORX M4xL16 T27	1	
					177	3238-13150	• NUT	1	
43	04065-03515	• RING, SNAP	1		178	T4950-63040	BOLT TORX M6xL30 T27	2	
44	3180-13330	• RING	1						
45	T4950-63540	• BOLT TORX	1						
46	848JL061F3	• HOLDER (A)	1						
47	848JL061L2	• PLATE	1						
48	848JL061G2	• HOLDER (B)	1						
49	848JL061K1	• NUT M12xP1.25	1						
50	848KH061J0	• COVER	1						
52	T4950-51200	• BOLT TORX M5xL12 T27	1						
53	848JL066C2	• PLATE	1						
90	848KH090R0	PLATE NAME	1						
91	6425-12552	PLATE	1						

Fig.5 ENGINE GROUP

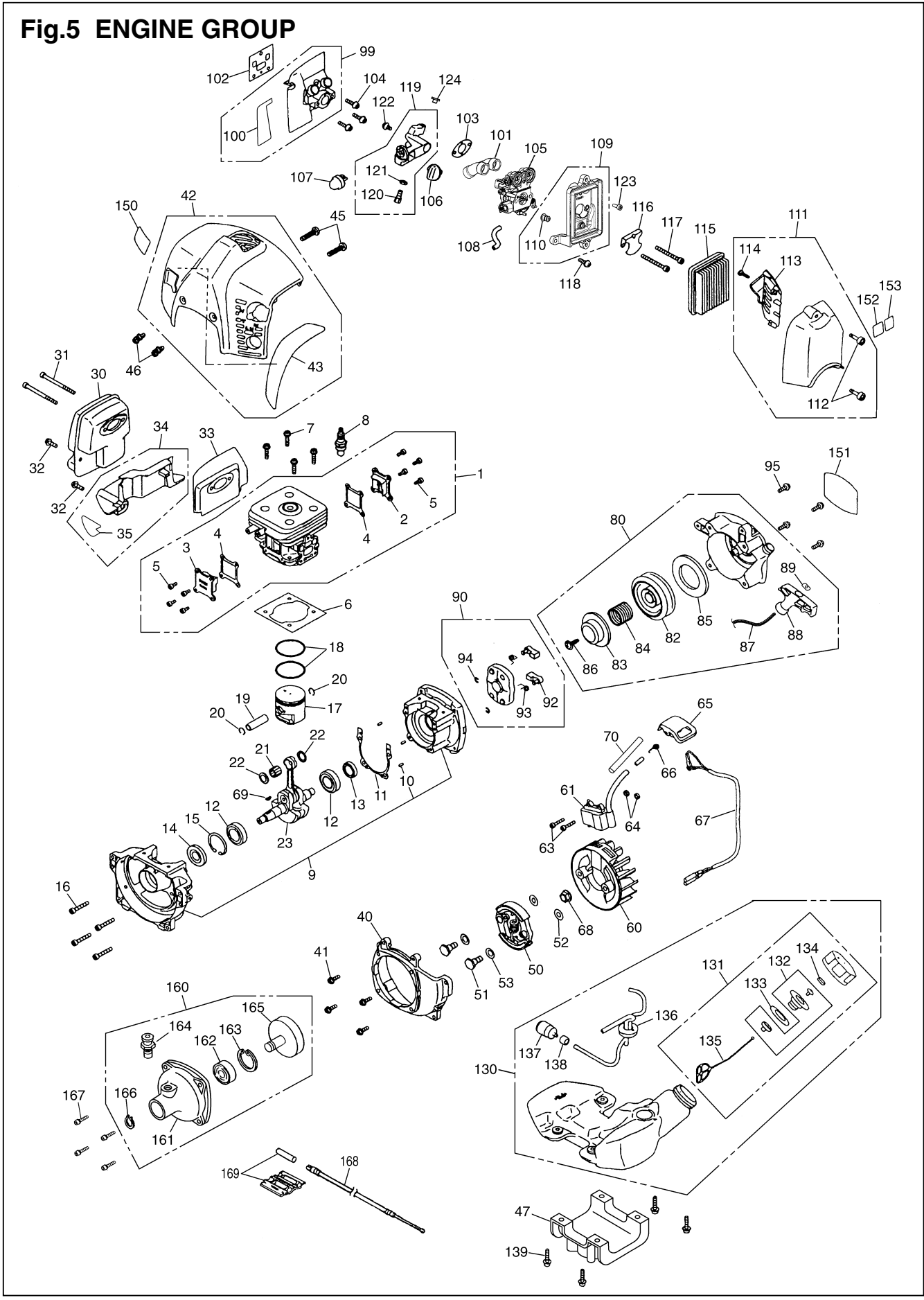
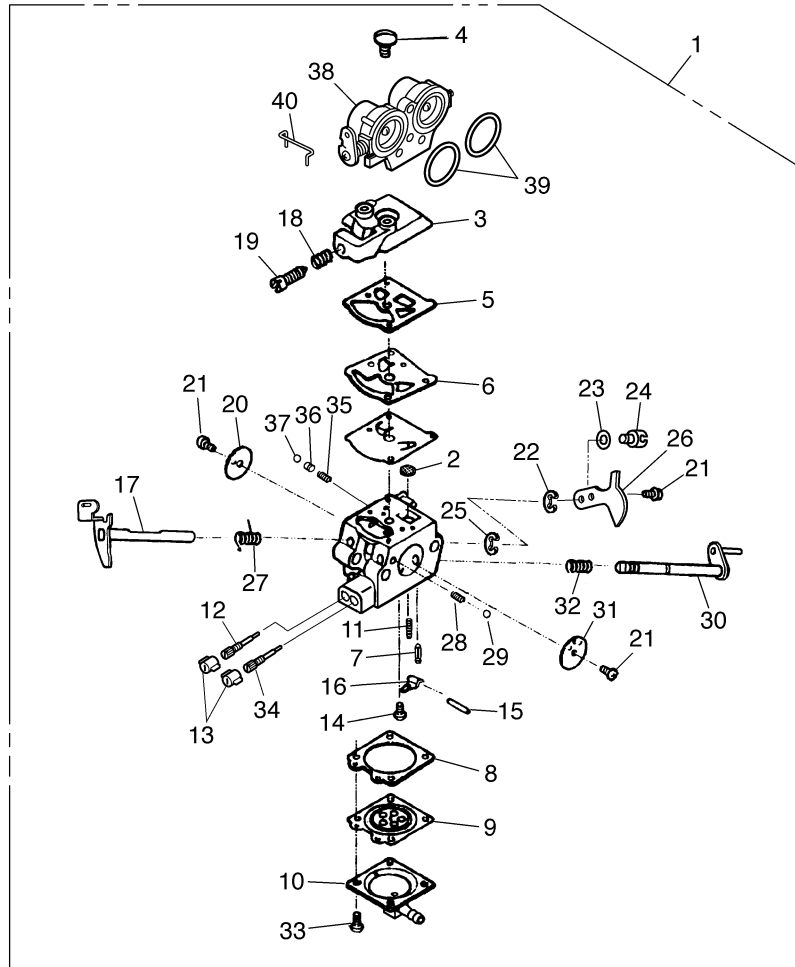

Fig.5 ENGINE GROUP

Key#	PART NUMBER	DESCRIPTION	Q'TY /UNIT	NOTE	Key#	PART NUMBER	DESCRIPTION	Q'TY /UNIT	NOTE
1	848H701211	CYLINDER COMP.	1		90	848H707521	PULLEY ASSY	1	
2	848H7012C1	• COVER, TR, S	1		92	848H7075R1	• RATCHET	2	
3	848H7012D1	• COVER, TR, F	1		93	848H7075S0	• SPRING	2	
4	848H7012E1	• GASKET, TR	2		94	1034-72180	• E RING	2	
5	4820-16310	• BOLT TORX M4xL10 T27	8		95	4820-32120	BOLT TORX	4	
6	848H7012B1	GASKET	1		99	848H711400	INSULATOR ASSY	1	
7	4820-12130	BOLT TORX M5xL22 T27	4		100	848H7114F0	• TAPE	1	
8	3699-91867	SPARK PLUG	1	CMR7H	101	848H7082A2	PIPE	1	
9	848H702111	CRANKCASE COMP.	1		102	848H7014B2	GASKET	1	
10	2629-21130	• PIN	3		103	848H7014C1	GASKET, CARB	1	
11	T1400-21140	GASKET, CASE	1		104	T4950-52021	BOLT TORX M5xL20 T27	3	
12	84889F3511	BEARING	2		105	848H708103	CARBURETOR ASSY	1	
13	T4019-21210	SEAL	1		106	848H7082F0	KNOB	1	
14	1400-21220	SEAL	1		107	2850-81900	PUMP	1	
15	04065-03515	RING, SNAP	1		108	8488F40450	TUBE	1	
16	4820-21310	BOLT TORX M5xL30 T27	4		109	848GG08310	BODY ASSY	1	
17	848H7041A2	PISTON	1		110	848GG083D0	• GROMMET	1	
18	T1400-41210	RING	2		111	848H708321	COVER ASSY	1	
19	2880-41310	PIN	1		112	8488052011	• SCREW	2	
20	3350-41320	SNAP RING	2		113	848H7083Y0	• GUARD	1	
21	1400-41410	BEARING	1		114	8488241600	• SCREW	1	
22	2670-41510	WASHER	2		115	848H7083F1	ELEMENT	1	
23	848H704201	CRANKSHAFT COMP.	1		116	T4012-82510	PLATE	1	
30	848H7115A1	MUFFLER	1		117	4820-15310	BOLT TORX M5xL50 T27	2	
31	8488156700	BOLT TORX M5xL67 T27	2		118	4820-85510	BOLT TORX M5xL16 T27	1	
32	4820-85510	BOLT TORX M5xL16 T27	2		119	848H718222	BRACKET ASSY	1	
33	848H7015C1	GASKET	1		120	T1610-13170	• SCREW	1	
34	848H711530	PLATE	1		121	0282-10604	• NUT	1	
35	848H7115F0	• TAPE	1		122	8488251601	SCREW M5xL16 T27	1	
40	848H7053A2	COVER	1		123	8488141200	BOLT M4x12 T27	1	
41	4820-85510	BOLT TORX M5xL16 T27	4		124	848GG082L1	STOPPER	1	
42	848H713110	COVER-TOP ASSY	1		130	848H718501	TANK ASSY	1	
43	848H7131E0	• TAPE	1		131	T1015-85202	• CAP ASSY	1	
45	T4970-52000	SCREW TORX 5xL20	2		132	4500-85300	•• HOLDER ASSY	1	
46	8488151002	BOLT TORX M5xL10 T27	2		133	4500-85220	•• PACKING	1	
47	848H7137D0	BRACKET	1		134	5601-85260	•• FILTER	1	
50	848H705110	SHOE COMP.	1		135	4820-85260	•• STOPPER	1	
51	1200-51211	SCREW	2		136	848H718530	• PIPE COMP.	1	
52	1200-51230	WASHER	2		137	3302-85400	• FILTER	1	
53	1200-51241	WASHER	2		138	2841-31280	• COLLER	1	
60	848H7471A0	ROTOR	1		139	T4950-53040	BOLT	4	
61	848H707122	COIL ASSY	1		150	848H7090B1	LABEL, COVER	1	
63	T4950-42200	BOLT TORX M4xL22 T27	2		151	848H7190C0	LABEL, RECOIL	1	
64	1260-71261	SPACER	2		152	2634-31420	LABEL (CE)	1	
65	T1400-72110	CAP	1		153	8488X01200	LABEL	1	
66	1900-72120	SPRING	1		160	6129-11100	HOUSING ASSY	1	
67	T1400-73200	CORD COMP.	1		161	6129-11110	• HOUSING	1	
68	1400-43230	NUT	1		162	06002-06001	• BEARING	1	
69	1000-43240	KEY	1		163	04065-02812	• RING	1	
70	2850-71320	TUBE	1		164	848EEN5321	• STOPPER COMP.	1	
80	848H707511	RECOIL ASSY	1		165	6278-12311	• DRUM	1	
82	848H7475C0	• REEL	1		166	04064-01210	• SNAP RING	1	
83	848H7075L1	• PLATE, CAM	1		167	T4950-62040	BOLT TORX M6xL20 T27	4	
84	848H7075K1	• SPRING, DAMPER	1		168	8488P40330	CABLE COMP.	1	
85	848H7075B1	• SPRING, SPIRAL	1		169	T1000-83300	JOINT ASSY	1	
86	848H7075E1	• SCREW	1						
87	848H7075F1	• ROPE	1						
88	848H7075J1	• KNOB	1						
89	848H7075G1	• STOPPER	1						

**Fig.6 CARBURETOR**



Key#	PART NUMBER	DESCRIPTION	Q'TY /UNIT	NOTE	Key#	PART NUMBER	DESCRIPTION	Q'TY /UNIT	NOTE
1	848H708103	CARBURETOR ASSY	1		24	1751-81141	• SWIVEL	1	
2	3306-81380	• SCREEN	1		25	1148-81390	• RING	1	
3	848H7081H0	• COVER	1		26	848H7181Z1	• LEVER, throttle	1	
4	848H7081P0	• SCREW	1		27	2670-81410	• SPRING	1	
5	3304-81140	• GASKET	1		28	3350-81350	• SPRING	1	
6	1172-81150	• DIAPHRAGM	1		29	3350-81220	• BALL	1	
7	3356-81310	• VALVE	1		30	848H7181E0	• SHAFT ASSY, choke	1	
8	2850-81290	• GASKET	1		31	848H7180C0	• VALVE	1	
9	3310-81260	• DIAPHRAGM	1		32	3350-81391	• SPRING	1	
10	848H7081G0	• COVER	1		33	3310-81351	• SCREW	4	
11	1488-81370	• SPRING	1		34	848H7181B0	• NEEDLE	1	
12	2812-81330	• NEEDLE	1		35	2810-81530	• SPRING	1	
13	3415-81490	• CAP	2		36	2812-81510	• PISTON	1	
14	3310-81240	• SCREW	1		37	2812-81520	• BALL	1	
15	3310-81250	• PIN	1		38	848H708200	• BODY ASSY, air valve	1	
16	3310-81230	• LEVER	1		39	848H7082A0	• RING, packing	2	
17	848H7081T1	• SHAFT	1		40	848H7082B0	• LINK ROD	1	
18	1282-81460	• SPRING	1						
19	1145-81540	• SCREW	1						
20	848H7081U1	• VALVE	1						
21	2880-81470	• SCREW	3						
22	1751-81130	• RING	1						
23	1751-81190	• WASHER	1						