



## Hydraulikmotoren Serie RL Moteurs hydrauliques série RL



### APPLICATION

- » Conveyors
- » Feeding mechanism of robots and manipulators
- » Metal working machines
- » Textile machines
- » Agricultural machines
- » Food industries
- » Mining machinery etc.

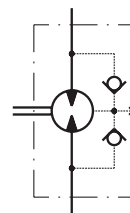

### OPTIONS

- » Model - Spool valve, roll-gerotor
- » Antifriction conical bearings
- » Flange mount
- » Shafts - straight, splined and tapered
- » Metric and BSPP ports
- » Other special features

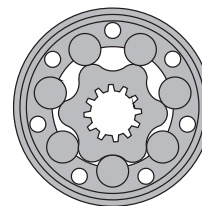

### GENERAL

<b>Max. Displacement</b>	cm <sup>3</sup> /rev. [in <sup>3</sup> /rev.]	397 [24.4]
<b>Max. Speed</b>	[RPM]	970
<b>Max. Torque</b>	daNm [lb-in]	cont.: 61 [5400] int.: 69 [6100]
<b>Max. Output</b>	kW [HP]	16 [21.5]
<b>Max. Pressure Drop</b>	bar [PSI]	cont.: 175 [2540] int.: 200 [2900]
<b>Max. Oil Flow</b>	lpm [GPM]	75 [20]
<b>Min. Speed</b>	[RPM]	10
<b>Permissible Shaft Loads</b>	daN [lbs]	P <sub>a</sub> =500 [1124]
<b>Pressure fluid</b>		Mineral based- HLP(DIN 51524) or HM(ISO 6743/4)
<b>Temperature range</b>	°C [°F]	-40÷140 [-40÷284]
<b>Optimal Viscosity range</b>	mm <sup>2</sup> /s [SUS]	20÷75 [98÷347]
<b>Filtration</b>		ISO code 20/16 (Min. recommended fluid filtration of 25 microns)

Oil flow in drain line

Pressure drop bar [PSI]	Viscosity mm <sup>2</sup> /s [SUS]	Oil flow in drain line lpm [GPM]
100 [1450]	20 [98]	2,5 [.660]
	35 [164]	1,8 [.476]
140 [2030]	20 [98]	3,5 [.925]
	35 [164]	2,8 [.740]

Pressure Losses

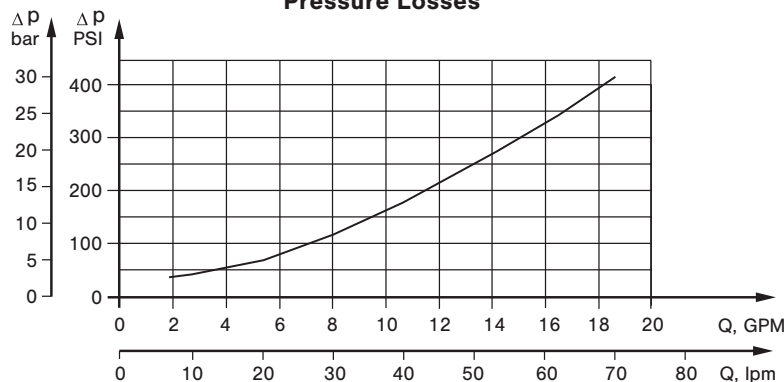

240-64.pdf

**Technische Informationen, Serie RL**  
**Informations techniques, série RL**

Type	RL 50	RL 80	RL 100	RL 125	RL 160	RL 200	RL 250	RL 315	RL 400
<b>Displacement, cm<sup>3</sup>/rev [in<sup>3</sup>/rev]</b>	51,5 [3.14]	80,3 [4.90]	99,8 [6.09]	125,7 [7.67]	159,6 [9.74]	199,8[12.19]	250,1[15.26]	315,7[19.26]	397 [24.4]
<b>Max. Speed</b>	775	750	600	475	375	300	240	190	150
<b>[RPM]</b>	970	940	750	600	470	375	300	240	190
<b>Max. Torque</b>	10 [885]	19,5 [1725]	24 [2125]	30 [2655]	38 [3360]	45 [4000]	54 [4780]	55 [4870]	61 [5400]
<b>daNm [lb-in]</b>	13 [1150]	22 [1947]	28 [2480]	34 [3010]	43 [3805]	50 [4425]	61 [5400]	69 [6100]	69 [6100]
	17 [1505]	27 [2390]	32 [2832]	37 [3275]	46 [4070]	56 [4960]	71 [6280]	84 [77430]	87 [7700]
<b>Max. Output</b>	7 [9.5]	12,5 [17]	13 [17.4]	12,5 [16.8]	12,5 [16.8]	11 [14.8]	10 [13.4]	9 [12]	7,5 [10]
<b>kW [HP]</b>	8,5 [11.9]	15 [20.1]	15 [20.1]	14,5 [19]	14 [18.8]	13 [17.4]	12 [16.1]	10 [13.4]	9 [12]
<b>Max. Pressure Drop</b>	140 [2030]	175 [2540]	175 [2540]	175 [2540]	175 [2540]	175 [2540]	175 [2540]	135 [1960]	110 [1600]
<b>bar [PSI]</b>	175 [2540]	200 [2900]	200 [2900]	200 [2900]	200 [2900]	200 [2900]	200 [2900]	175 [2540]	140 [2030]
	225 [3260]	225 [3260]	225 [3260]	225 [3260]	225 [3260]	225 [3260]	225 [3260]	210 [3045]	175 [2540]
<b>Max. Oil Flow</b>	40 [11]	60 [16]	60 [16]	60 [16]	60 [16]	60 [16]	60 [16]	60 [16]	60 [16]
<b>lpm [GPM]</b>	50 [13]	75 [20]	75 [20]	75 [20]	75 [20]	75 [20]	75 [20]	75 [20]	75 [20]
<b>Max. Inlet Pressure</b>	175 [2540]	175 [2540]	175 [2540]	175 [2540]	175 [2540]	175 [2540]	175 [2540]	175 [2540]	175 [2540]
<b>bar [PSI]</b>	200 [2900]	200 [2900]	200 [2900]	200 [2900]	200 [2900]	200 [2900]	200 [2900]	200 [2900]	200 [2900]
	225 [3260]	225 [3260]	225 [3260]	225 [3260]	225 [3260]	225 [3260]	225 [3260]	225 [3260]	225 [3260]
<b>Max. Return Pressure</b>	100 [1450]	100 [1450]	100 [1450]	100 [1450]	100 [1450]	100 [1450]	100 [1450]	100 [1450]	100 [1450]
<b>without Drain</b>	50 [725]	50 [725]	50 [725]	50 [725]	50 [725]	50 [725]	50 [725]	50 [725]	50 [725]
<b>Line or Max. Pressure</b>	25 [365]	25 [365]	25 [365]	25 [365]	25 [365]	25 [365]	25 [365]	25 [365]	25 [365]
<b>in Drain Line</b>	15 [220]	15 [220]	15 [220]	15 [220]	15 [220]	15 [220]	15 [220]	15 [220]	15 [220]
<b>bar [PSI]</b>	100 [1450]	100 [1450]	100 [1450]	100 [1450]	100 [1450]	100 [1450]	100 [1450]	100 [1450]	100 [1450]
<b>Max. Return Pressure</b>	140 [2030]	175 [2540]	175 [2540]	175 [2540]	175 [2540]	175 [2540]	175 [2540]	175 [2540]	175 [2540]
<b>with Drain Line</b>	175 [2540]	200 [2900]	200 [2900]	200 [2900]	200 [2900]	200 [2900]	200 [2900]	200 [2900]	200 [2900]
<b>bar [PSI]</b>	225 [3260]	225 [3260]	225 [3260]	225 [3260]	225 [3260]	225 [3260]	225 [3260]	225 [3260]	225 [3260]
<b>Max. Starting Pressure with Unloaded Shaft, bar [PSI]</b>	10 [145]	10 [145]	10 [145]	9 [130]	7 [102]	5 [73]	5 [73]	5 [73]	5 [73]
<b>Min. Starting Torque daNm [lb-in]</b>	8 [710]	15 [1330]	20 [1770]	25 [2215]	32 [2835]	37 [3275]	45 [3983]	45 [3983]	49 [4335]
<b>Min. Speed***, [RPM]</b>	10	10	10	10	10	10	10	10	10
<b>Weight, kg [lb]</b>	7,7 [17]	7,8 [17.2]	8,1 [17.8]	8,2 [18]	8,4 [18.5]	8,9 [19.6]	9,3 [20.5]	10,0 [22]	10,7 [23.6]

\* Intermittent operation: the permissible values may occur for max. 10% of every minute.

\*\* Peak load: the permissible values may occur for max. 1% of every minute.

\*\*\* For speeds lower than given, consult factory or your regional manager.

- Intermittent speed and intermittent pressure must not occur simultaneously.
- Recommended filtration is per ISO cleanliness code 20/16. A nominal filtration of 25 micron or better.
- Recommend using a premium quality, anti-wear type mineral based hydraulic oil HLP(DIN51524) or HM ( ISO 6743/4).  
If using synthetic fluids consult the factory for alternative seal materials.
- Recommended minimum oil viscosity 13 mm<sup>2</sup>/s [70 SUS] at 50°C [122°F].
- Recommended maximum system operating temperature is 82°C [180°F].
- To assure optimum motor life fill with fluid prior to loading and run at moderate load and speed for 10-15 minutes.



**Leistungs-Diagramme, Serie RL 50/80**  
**Diagrammes de puissance, série RL 50/80**

RL 50

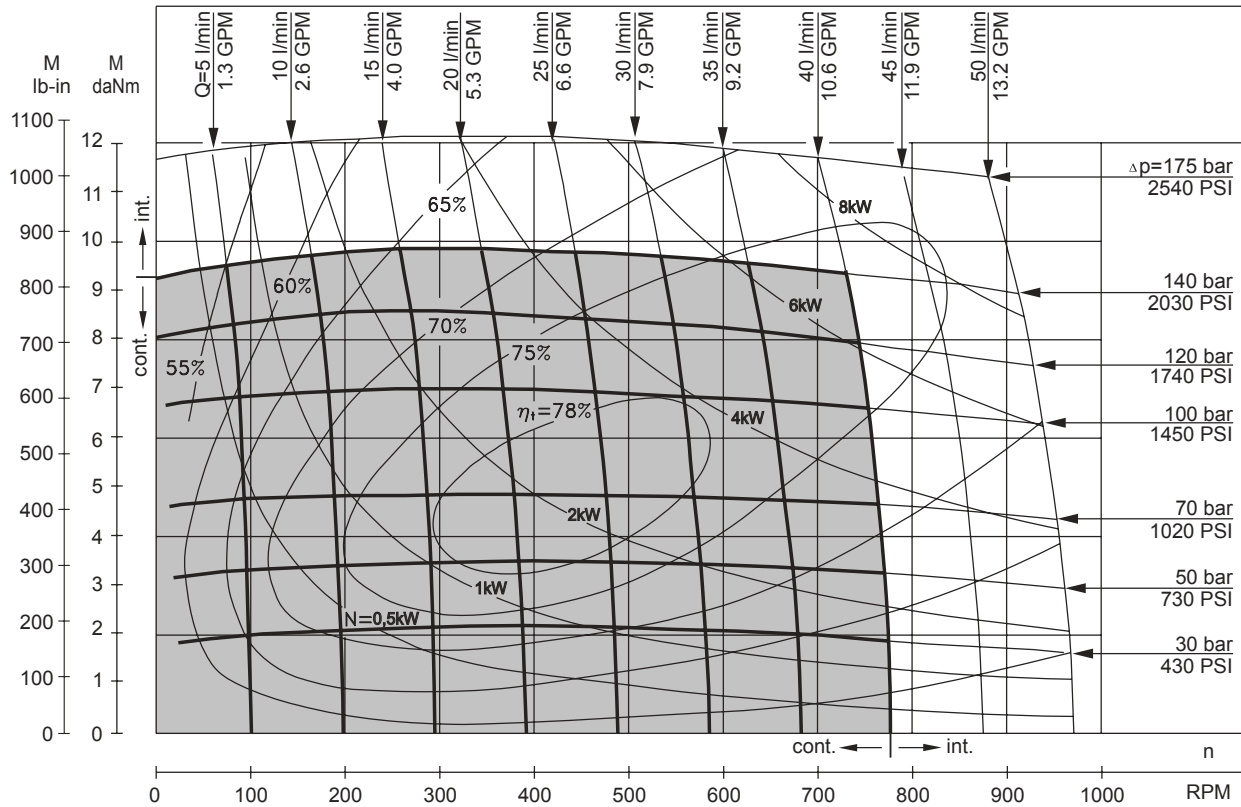

RL 80

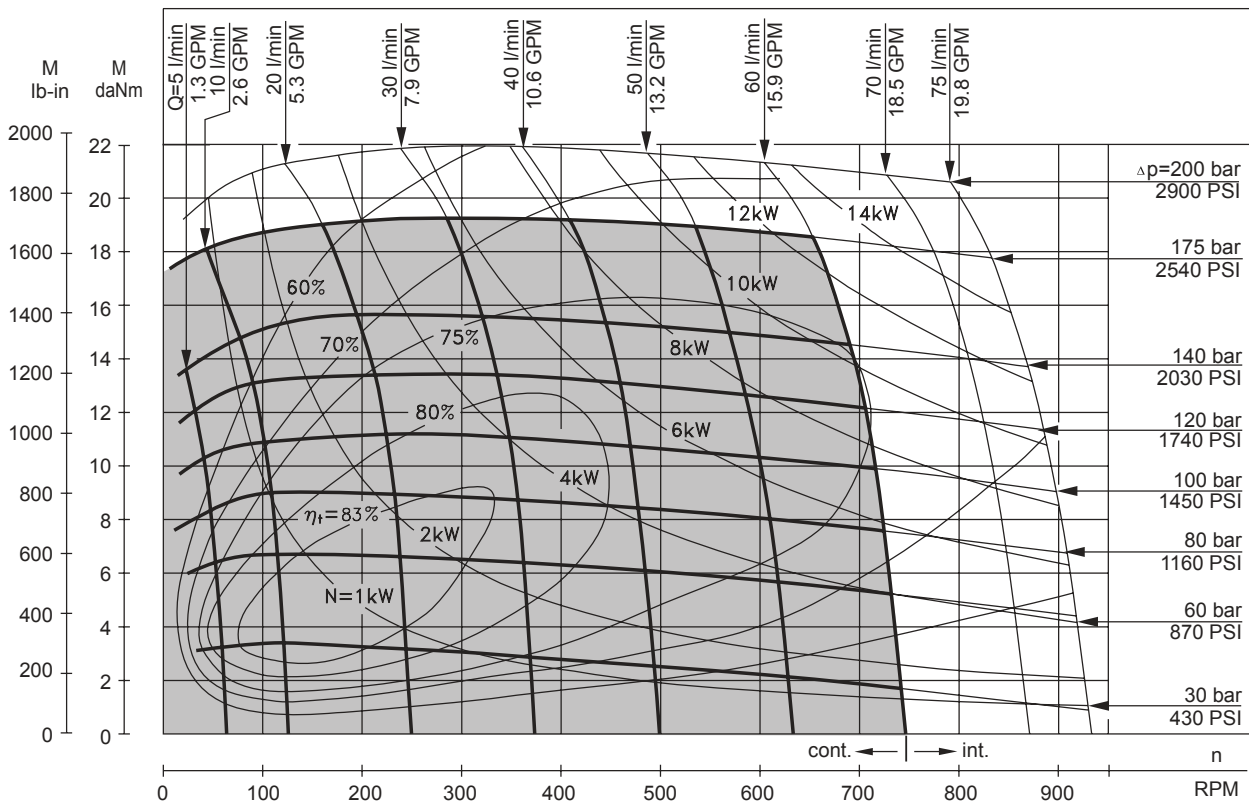

The function diagrams data is for average performance of randomly selected motors at back pressure 5÷10 bar [72.5÷145 PSI] and oil with viscosity of 32 mm<sup>2</sup>/s [150 SUS] at 50°C [122°F].

240-66.pdf



**Leistungs-Diagramme, Serie RL 100/125**  
**Diagrammes de puissance, série RL 100/125**

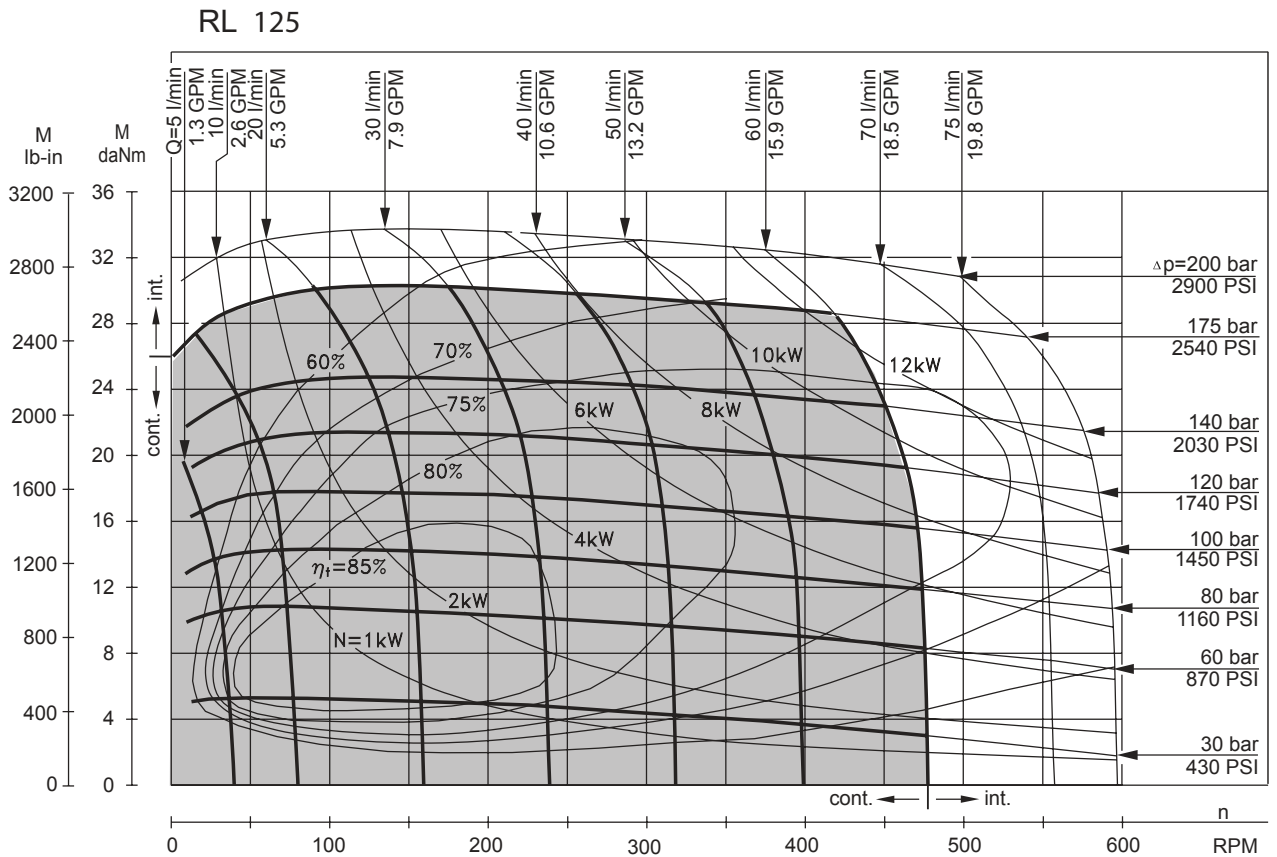
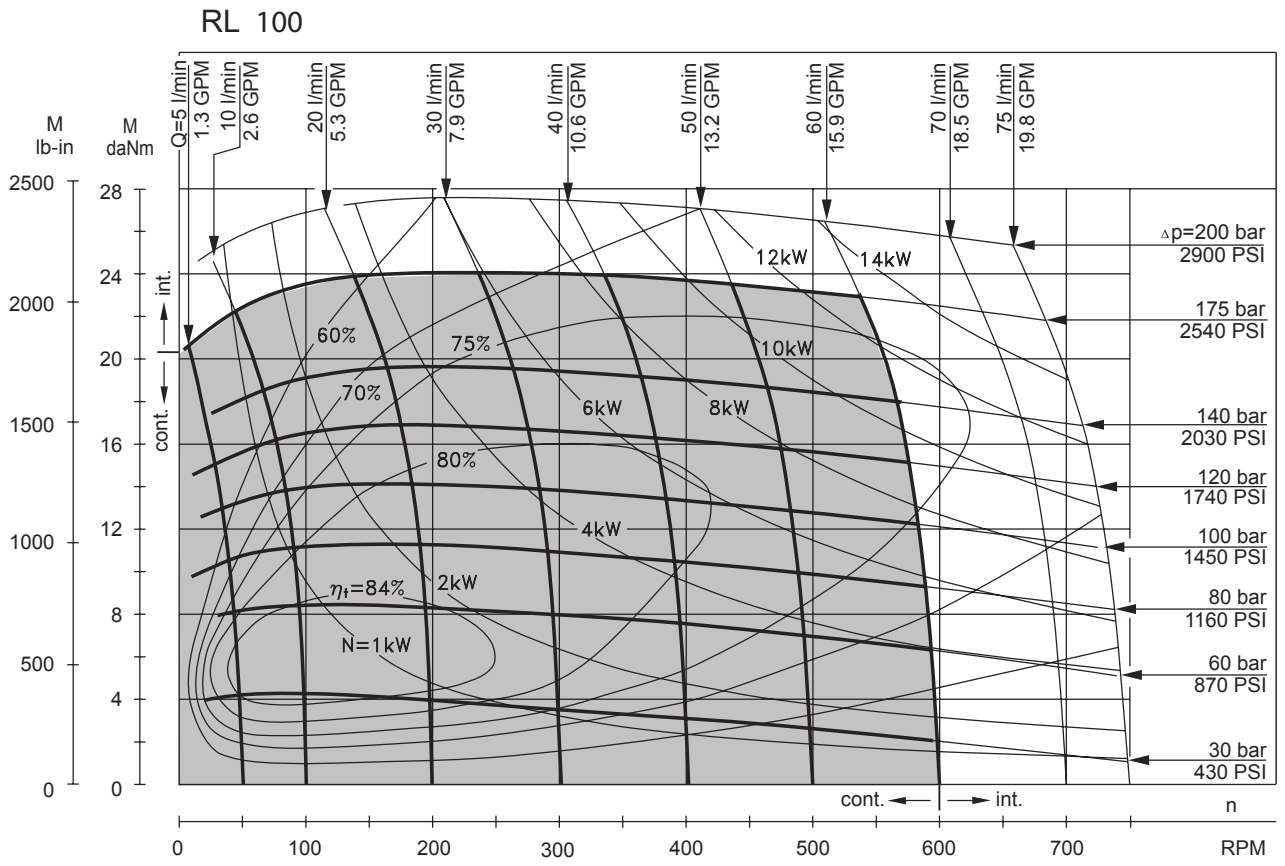

The function diagrams data is for average performance of randomly selected motors at back pressure 5÷10 bar [72.5÷145 PSI] and oil with viscosity of 32 mm<sup>2</sup>/s [150 SUS] at 50°C [122°F].

240-67.pdf



# Leistungs-Diagramme, Serie RL 160/200

## Diagrammes de puissance, série RL 160/200

RL 160

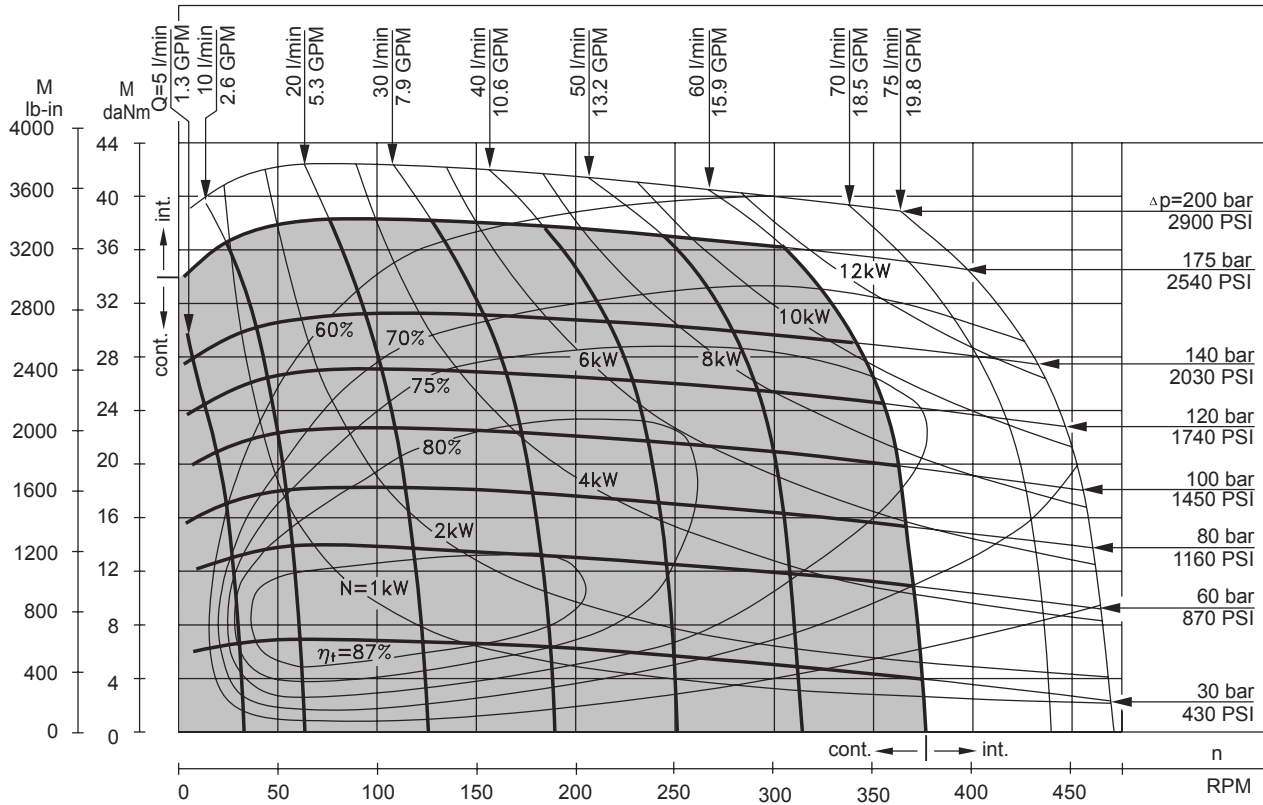

RL 200

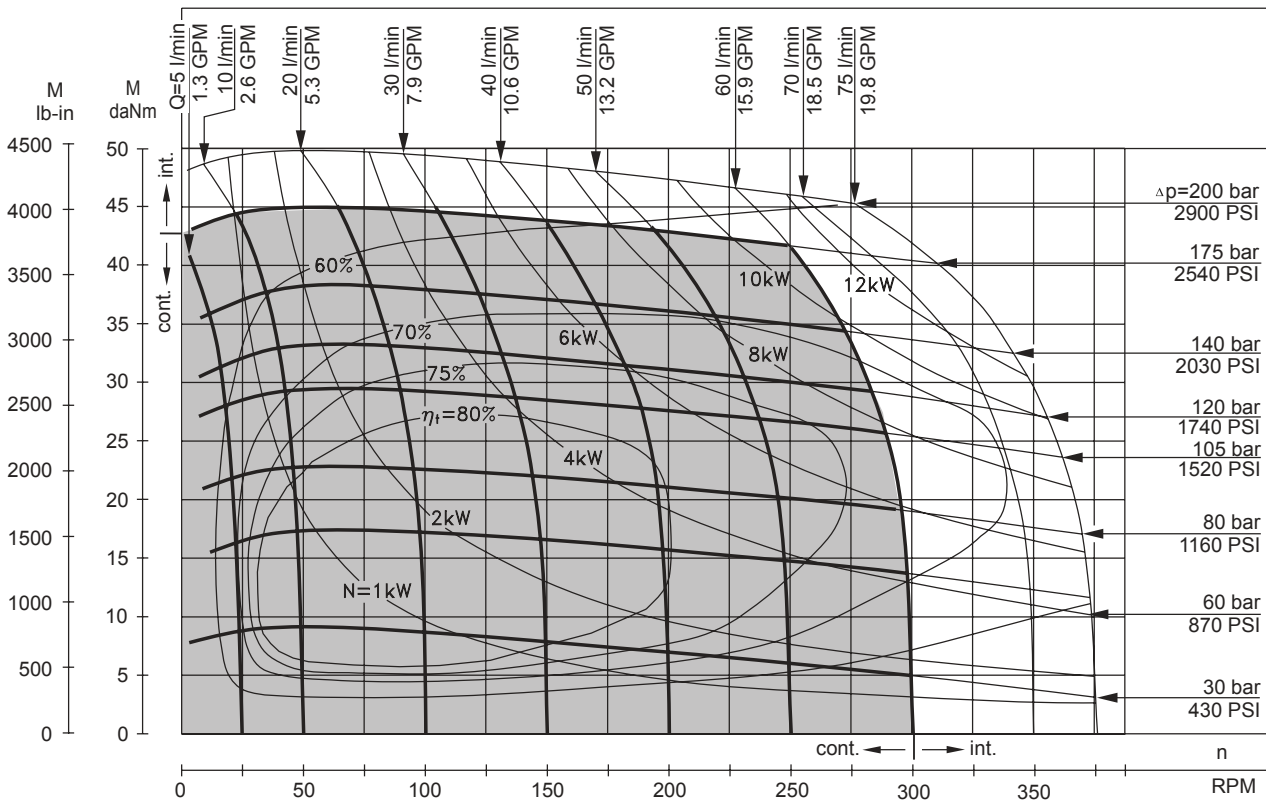

The function diagrams data is for average performance of randomly selected motors at back pressure 5÷10 bar [72.5÷145 PSI] and oil with viscosity of 32 mm<sup>2</sup>/s [150 SUS] at 50°C [122°F].

240-68.pdf





**Leistungs-Diagramme, Serie RL 250/315**  
**Diagrammes de puissance, série RL 250/315**

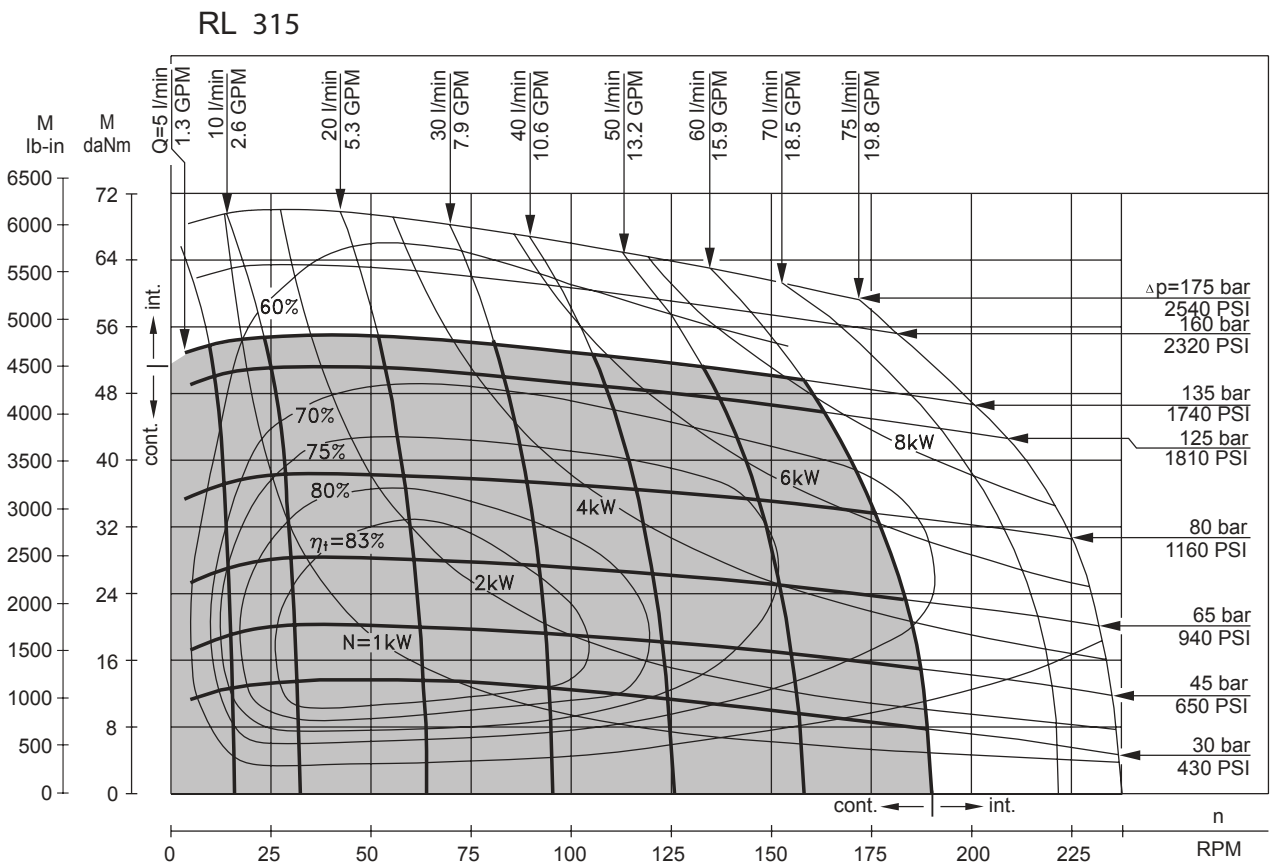
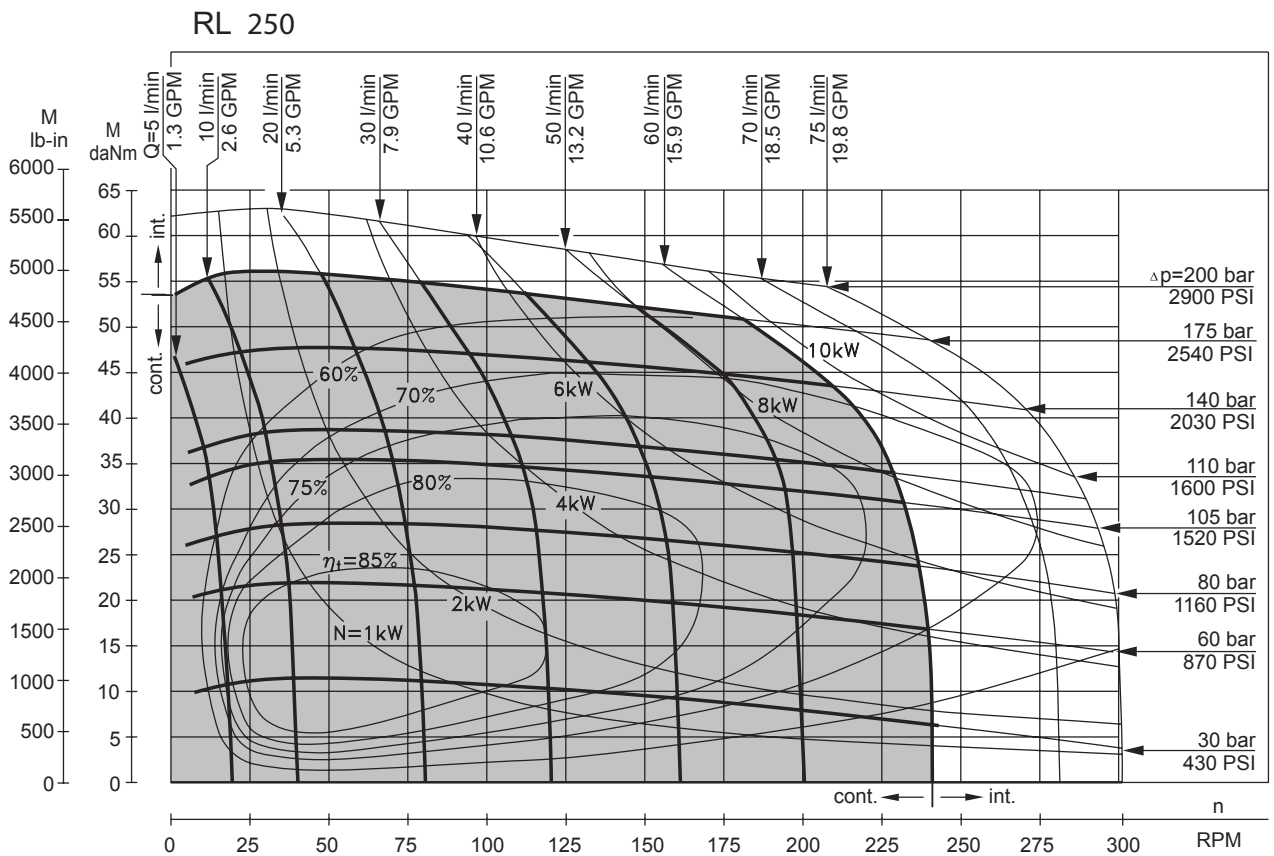

The function diagrams data is for average performance of randomly selected motors at back pressure 5÷10 bar [72.5÷145 PSI] and oil with viscosity of 32 mm<sup>2</sup>/s [150 SUS] at 50°C [122°F].



**Leistungs-Diagramme,, Serie RL 400**  
**Diagrammes de puissance, série RL 400**

RL 400

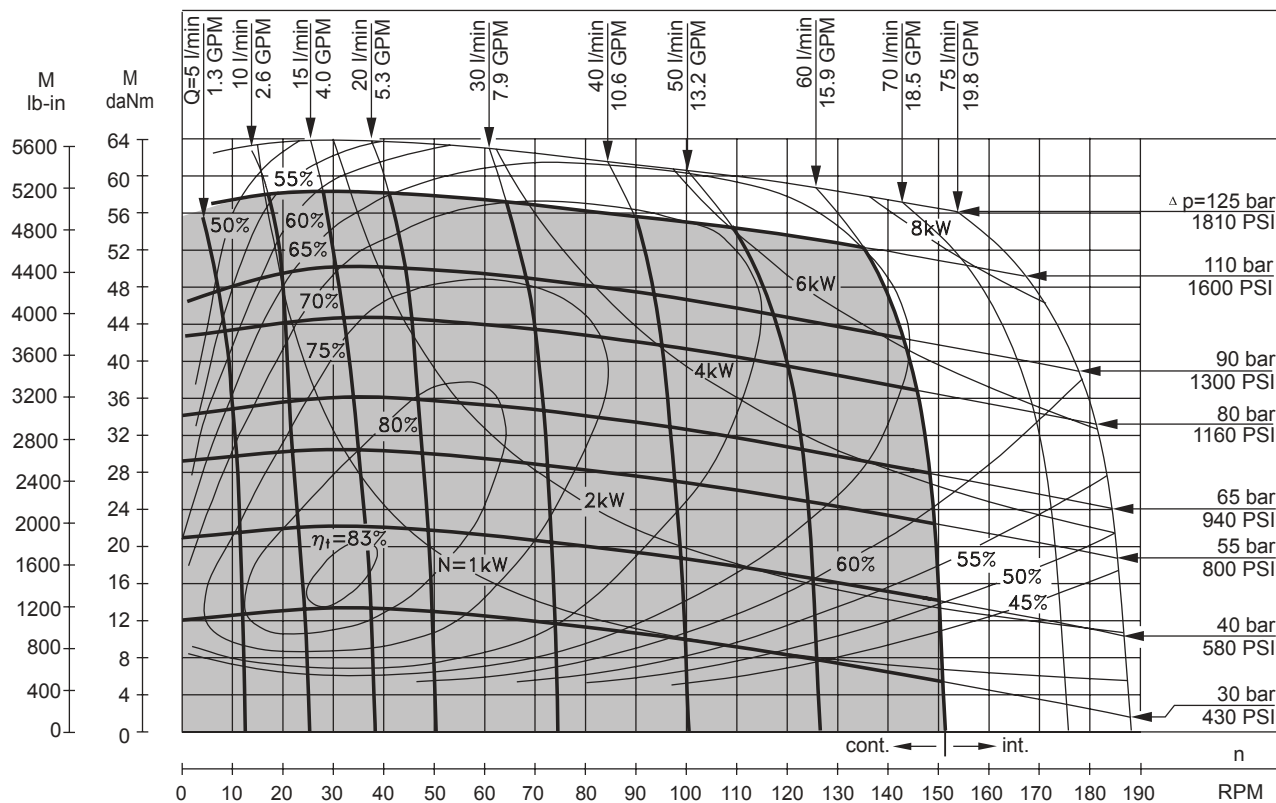

The function diagrams data is for average performance of randomly selected motors at back pressure 5÷10 bar [72.5÷145 PSI] and oil with viscosity of 32 mm<sup>2</sup>/s [150 SUS] at 50°C [122°F].

240-70.pdf



**Abmessungen- und Montage-Daten, Serie RL**  
**Dimensions et données d'installation, série RL**

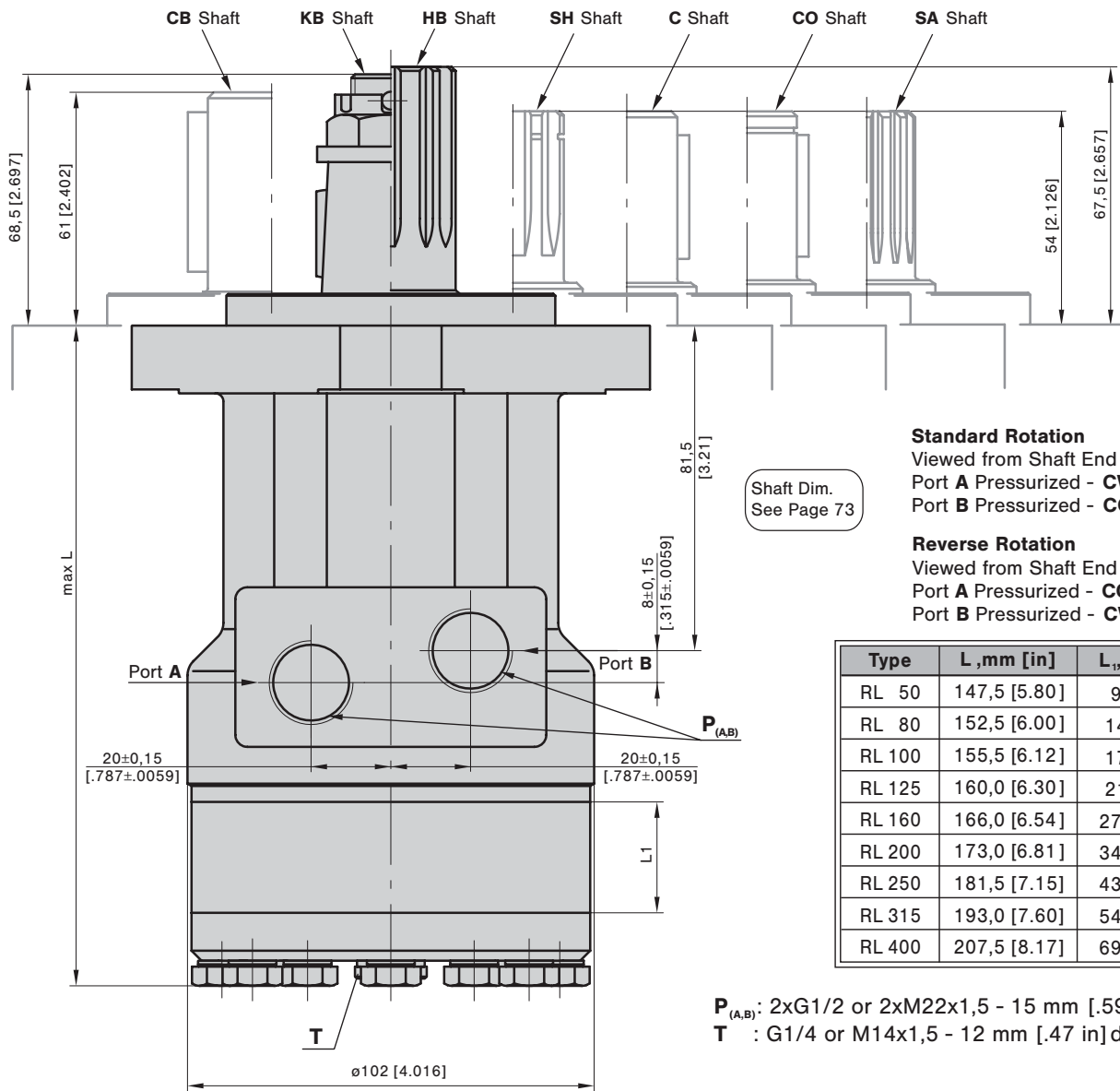

Shaft Dim.  
See Page 73

**Standard Rotation**  
Viewed from Shaft End  
Port A Pressurized - CW  
Port B Pressurized - CCW

**Reverse Rotation**  
Viewed from Shaft End  
Port A Pressurized - CCW  
Port B Pressurized - CW

Type	L, mm [in]	L <sub>1</sub> , mm [in]
RL 50	147,5 [5.80]	9,0 [0.35]
RL 80	152,5 [6.00]	14,0 [0.55]
RL 100	155,5 [6.12]	17,4 [0.69]
RL 125	160,0 [6.30]	21,8 [0.86]
RL 160	166,0 [6.54]	27,8 [1.09]
RL 200	173,0 [6.81]	34,8 [1.37]
RL 250	181,5 [7.15]	43,5 [1.71]
RL 315	193,0 [7.60]	54,8 [2.16]
RL 400	207,5 [8.17]	69,4 [2.73]

**P<sub>(A,B)</sub>**: 2xG1/2 or 2xM22x1,5 - 15 mm [.59 in] depth  
**T** : G1/4 or M14x1,5 - 12 mm [.47 in] depth



**MOUNTING**

**Square Mount (4 Holes)**

**F Oval Mount (4 Holes)**

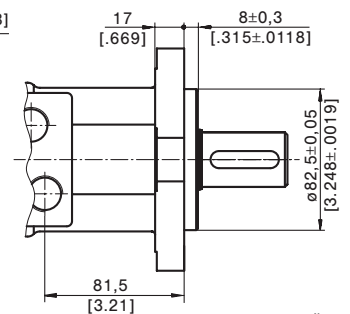
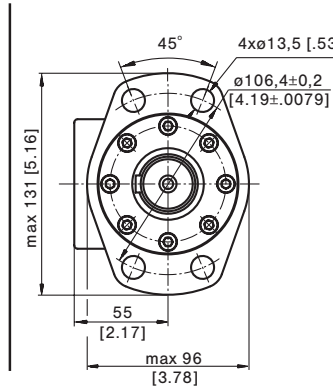
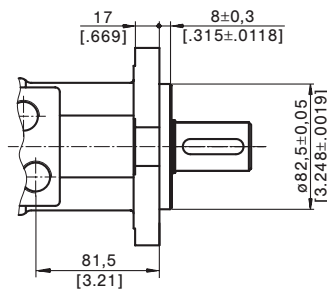
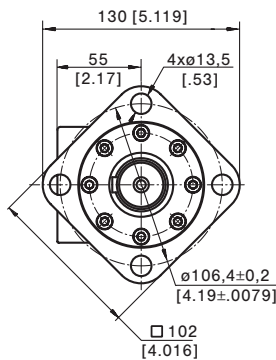

240-71.pdf





## Anschlusswellen für RL Motoren Arbre de transmission pour moteurs RL

**C** -  $\varnothing 25$  straight, Parallel key A8x7x30 DIN 6885  
Max. Torque 34 daNm [3010 lb-in]

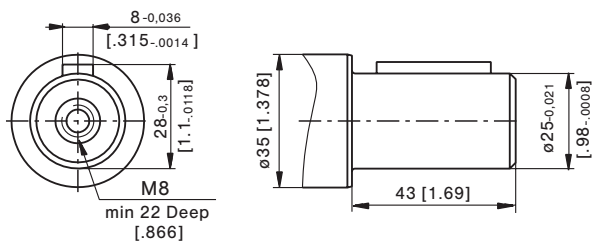

**SA** - splined B25x22 DIN 5482  
Max. Torque 40 daNm [3540 lb-in]

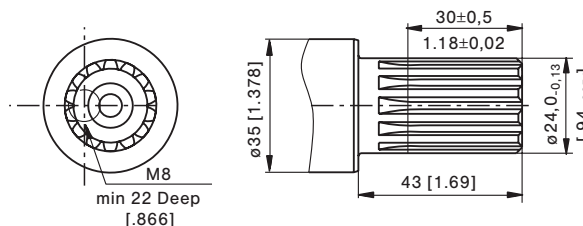

**CO** -  $\varnothing 1$ " straight, Parallel key  $1/4$ "x $1/4$ "x $1 1/4$ " BS46  
Max. Torque 34 daNm [3010 lb-in]

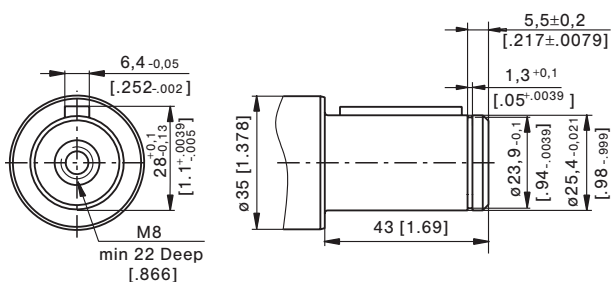

**CB** -  $\varnothing 32$  straight, Parallel key A10x8x40 DIN 6885  
Max. Torque 77 daNm [6815 lb-in]

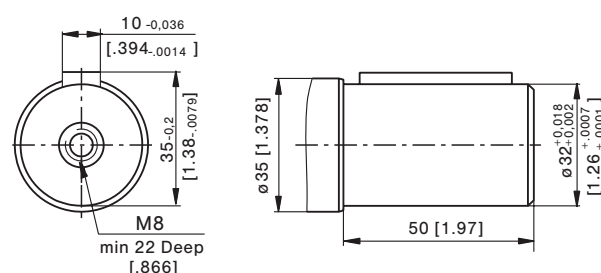

**SH** - splined, BS 2059 (SAE 6B)  
Max. Torque 40 daNm [3540 lb-in]

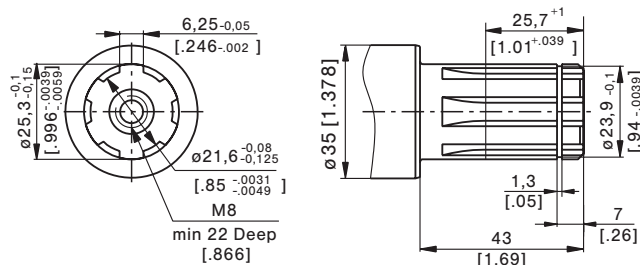

**HB** -  $\varnothing 1 1/4$ " splined 14T, DP12/24 ANSI B92.1-1976  
Max. Torque 95 daNm [8410 lb-in]

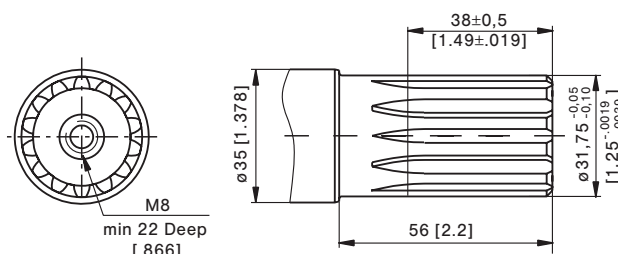

**KB** - tapered 1:10, Woodruff key 6x9 DIN6888  
Max. Torque 95 daNm [8410 lb-in]

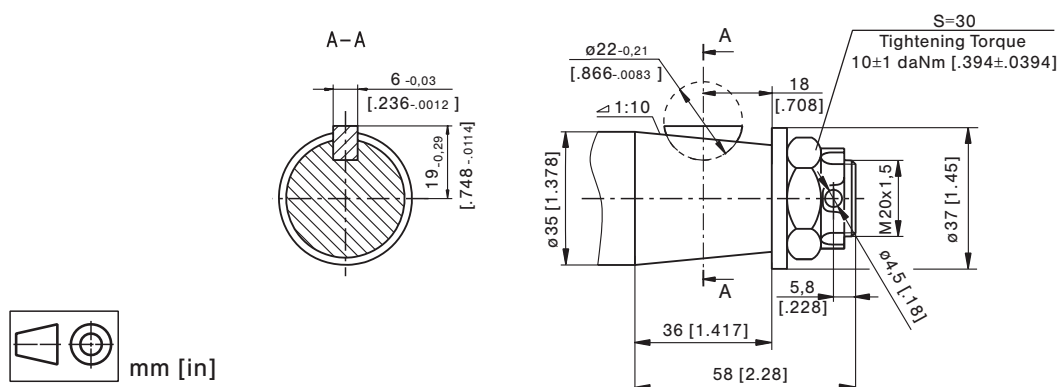



## Zulässige Wellenbelastung für RL Motoren Charges d'arbre admissibles pour moteurs RL

The curves apply to a B10 bearings life of 2000 hrs

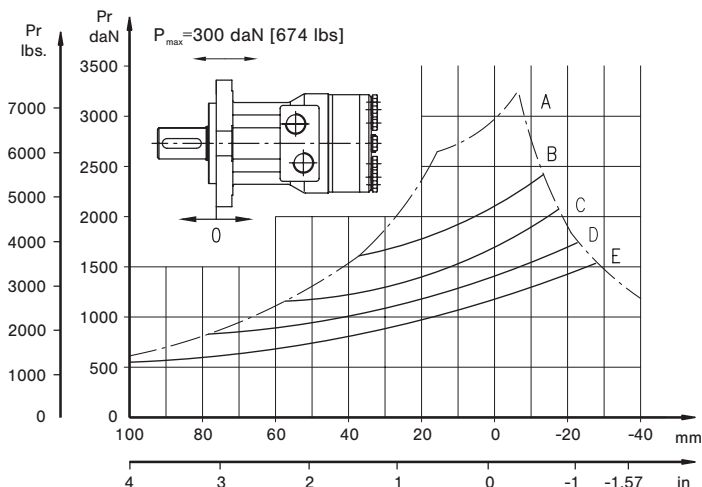

- A** - Max. radial shaft load
- B** -  $n=50 \text{ min}^{-1}$
- C** -  $n=100 \text{ min}^{-1}$
- D** -  $n=200 \text{ min}^{-1}$
- E** -  $n=400 \text{ min}^{-1}$

### MAX. PERMISSIBLE SHAFT SEAL PRESSURE

Max return pressure without drain line or max. pressure in drain line

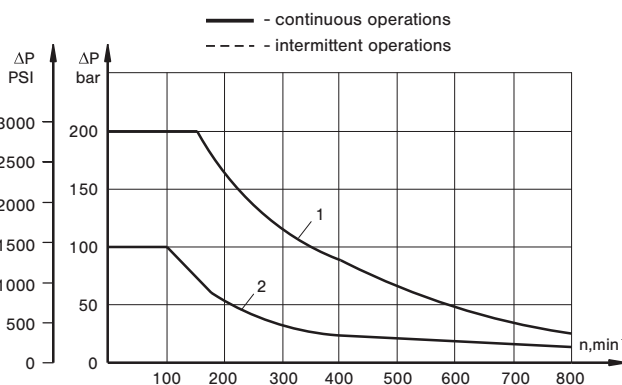

### BESTELLSCHLÜSSEL / CODE DE COMMANDE

	1	2	3	4	5	6
<b>RL</b>						

**Pos.1 - Mounting Flange**

omit - Square mount, four holes

**F** - Oval mount, four holes

**Pos.2 - Displacement code**

<b>50</b>	- 51,5 cm <sup>3</sup> /rev [3.14 in <sup>3</sup> /rev]
<b>80</b>	- 80,3 cm <sup>3</sup> /rev [4.90 in <sup>3</sup> /rev]
<b>100</b>	- 99,8 cm <sup>3</sup> /rev [6.09 in <sup>3</sup> /rev]
<b>125</b>	- 125,7 cm <sup>3</sup> /rev [7.67 in <sup>3</sup> /rev]
<b>160</b>	- 159,6 cm <sup>3</sup> /rev [9.74 in <sup>3</sup> /rev]
<b>200</b>	- 199,8 cm <sup>3</sup> /rev [12.19 in <sup>3</sup> /rev]
<b>250</b>	- 250,1 cm <sup>3</sup> /rev [15.26 in <sup>3</sup> /rev]
<b>315</b>	- 315,7 cm <sup>3</sup> /rev [19.26 in <sup>3</sup> /rev]
<b>400</b>	- 397,0 cm <sup>3</sup> /rev [24.40 in <sup>3</sup> /rev]

**Pos.3 - Shaft Extensions\*\***

- C** -  $\emptyset 25$  straight, Parallel key A8x7x35 DIN6885
- CO** -  $\emptyset 1"$  straight, Parallel key  $\frac{1}{4}" \times \frac{1}{4}" \times 1 \frac{1}{4}"$  BS46
- SH** -  $\emptyset 25,3$  splined, BS 2059 (SAE 6B)
- SA** -  $\emptyset 24$  splined, B 25x22 DIN 5482
- CB** -  $\emptyset 32$  straight, Parallel key A10x8x40 DIN6885
- HB** -  $\emptyset 1 \frac{1}{4}"$  splined 14T ANSI B92.1-1976
- KB** -  $\emptyset 35$  tapered 1:10, Woodruff key 6x9 DIN6888

**Pos.4 - Shaft Seal Version**

- omit - Standard shaft seal
- U** - High pressure shaft seal

**Pos.4 - Ports**

- omit - BSPP (ISO 228)
- M** - Metric (ISO 262)

**Pos.5 - Special Features**

**Pos.6 - Design Series**

- omit - Factory specified

**NOTES:** \*\* The permissible output torque for shafts must not be exceeded!  
The hydraulic motors are manganophosphatized as standard.