

Ersatzteilliste EFCO
Liste des pièces de rechange EFCO

EF106J/18H 2011

Illustration Motor

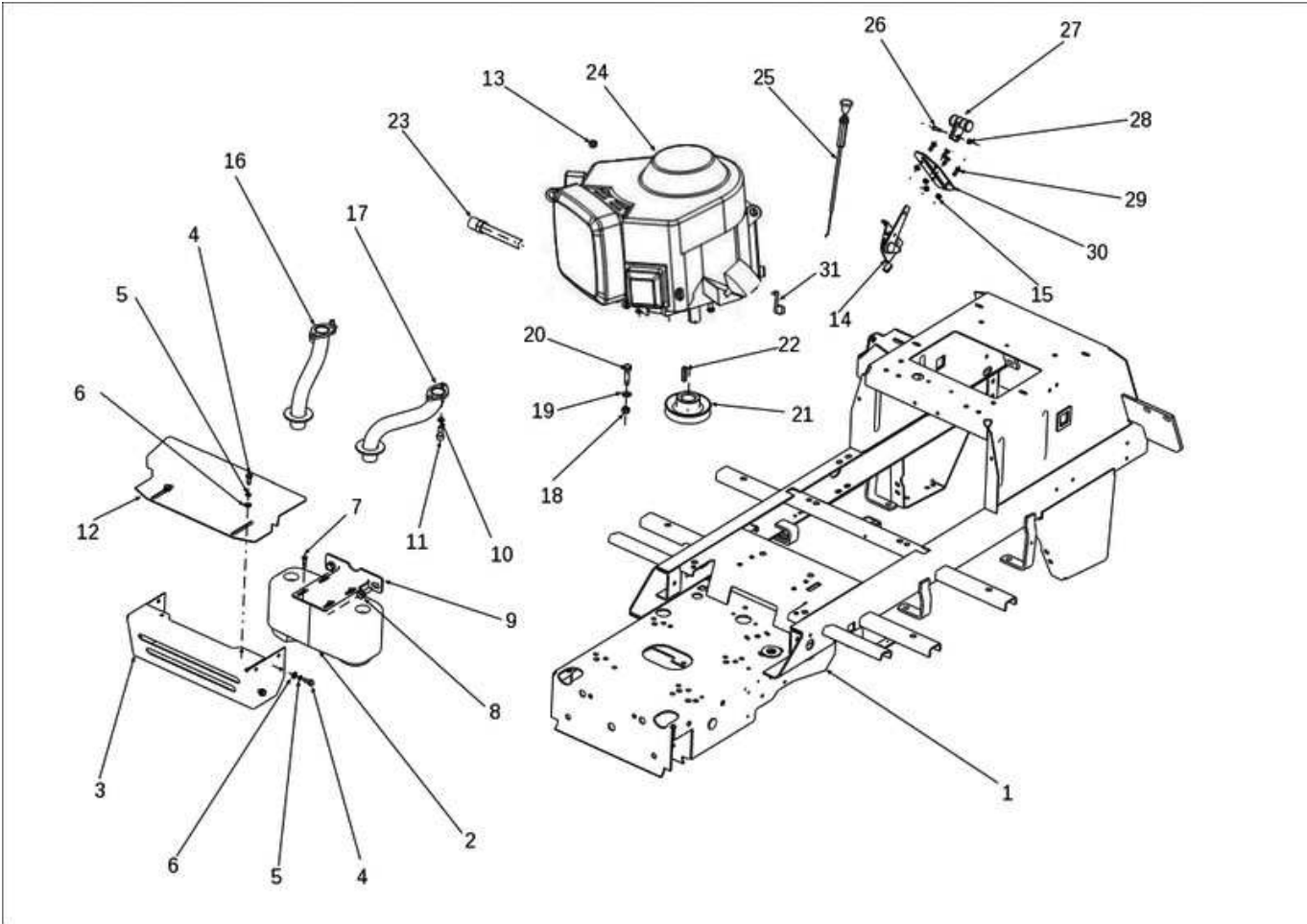

Illustration Motor

Bild Nr.	St.-Zahl	Teile Nr.	Beschreibung
1	1	SGS53291296277	Chassis
2	1	SGN443900129	Auspuff
3	1	SGS53208542729	Deckel
4	6	SGN309503508	Schraube
5	6	SGN311210502	Scheibe
6	6	SGN311214501	Scheibe
7	4	SGN309315016	Schraube
8	2	SGN309503005	Schraube
9	1	SGS53211340501	Halter
10	4	SGN311214502	Scheibe
11	4	SGN309503518	Schraube
12	1	SGS53208541574	Deckel
13	1	SGN311122501	Mutter
14	1	SGN000443006	Hebel
15	4	SGN311129515	Mutter
16	1	SGS53292744222	Rohr
17	1	SGS53292744223	Rohr
18	4	SGN311129501	Mutter
19	4	SGN311210503	Scheibe
20	4	SGN309503543	Schraube
21	1	SG532150439	Scheibe
22	1	SG532092312133	Schlüssel
23	1	SG532927262043	Verlaengerung
24	-		Nicht verfügbar für diesen produkt
25	1	SG443612011	Hebel
26	1	SGN309231535	Schraube
27	1	SGN443900138	Gashebel
28	1	SGN311129514	Mutter
29	4	SGN309251515	Schraube
30	1	SGS53208030287	Verstaerkung
31	1	SGN532980071	Haken

Illustration Vorderachse

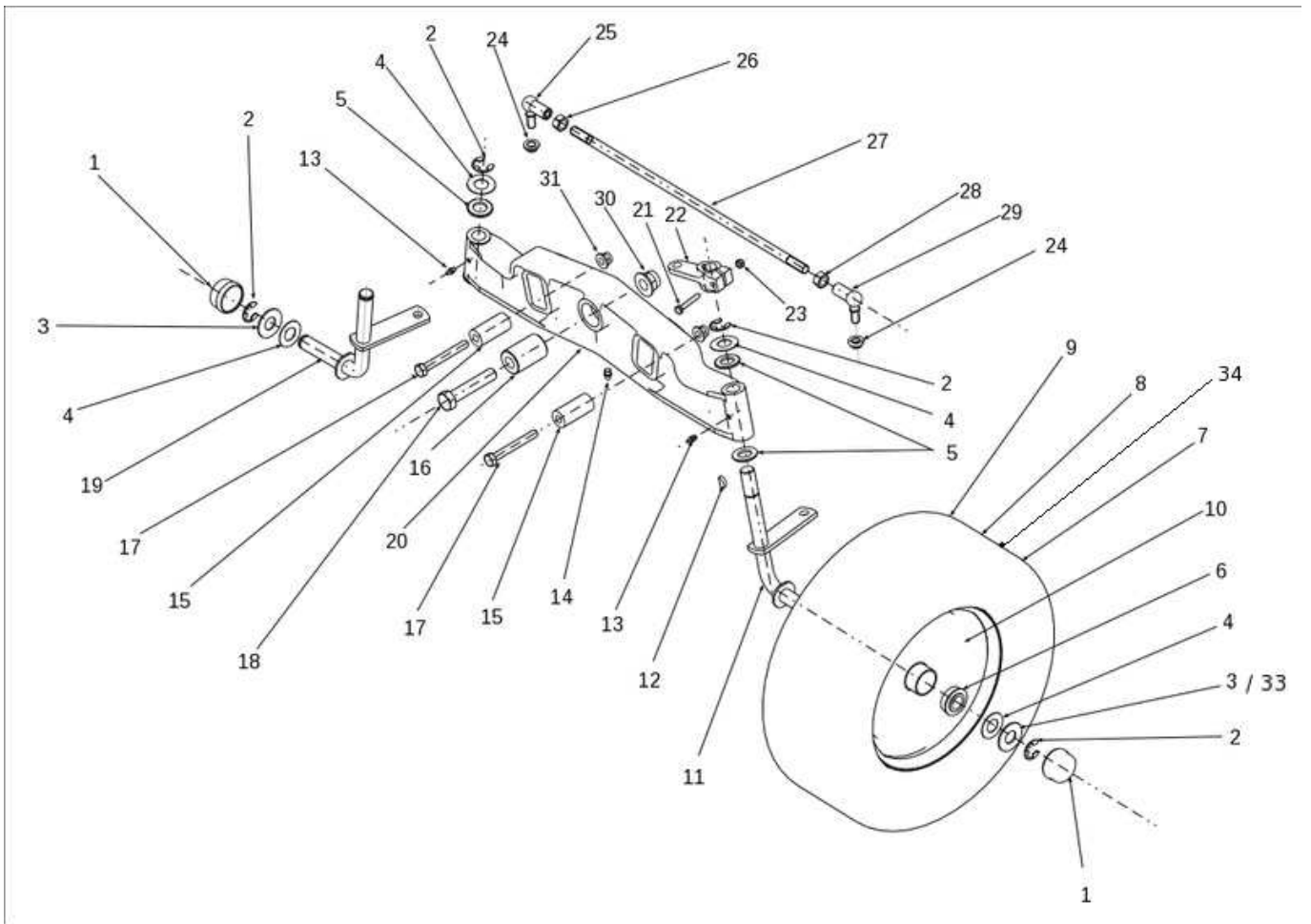

Illustration Vorderachse

Bild Nr.	St.- Zahl	Teile Nr.	Beschreibung
1	2	SGN532150915	Deckel
2	4	SGN311732008	Ring
3	2	SG532092208363	Scheibe
4	4	SGS53209220838	Scheibe
5	2	SGN311210514	Scheibe
6	4	SGN324196019	Lager
7	2	SGN532940133	Vorderrad
8	2	SGN274161023	Reifen vor
9	2	SGN000532135	Ventil
10	2	SG000532124	Schneidblatt
11	1	SG532916432143	Stift
12	1	SGN311728003	Schlüssel
13	2	SGN425111004	Fettnippel
14	1	SGN425111016	Fettnippel
15	2	SGN532150543	Distanzstück
16	1	SGN532150983	Stift
17	2	SGN309501527	Schraube
18	1	SGN309501524	Schraube
19	1	SG532916432153	Stift
20	1	SGS53201654206	Vorn achse
21	1	SGN309203524	Sechskantschraube
22	1	SGS53208050360	Hebel
23	1	SGN311129513	Sichermutter
24	2	SGN311129521	Mutter
25	1	SG947442073020	Dichtung
26	1	SGN311120504	Sechskantmutter
27	1	SG532980126	Stange
28	1	SGN311120539	Mutter
29	1	SGN442073019	Winkelstahl
30	1	SGN311129527	Mutter
31	2	SGN311129523	Mutter
33	1	SGS53209220815	Scheibe
34	2	SGN000532125	Reifenschlauch

Illustration Lenkgetriebe

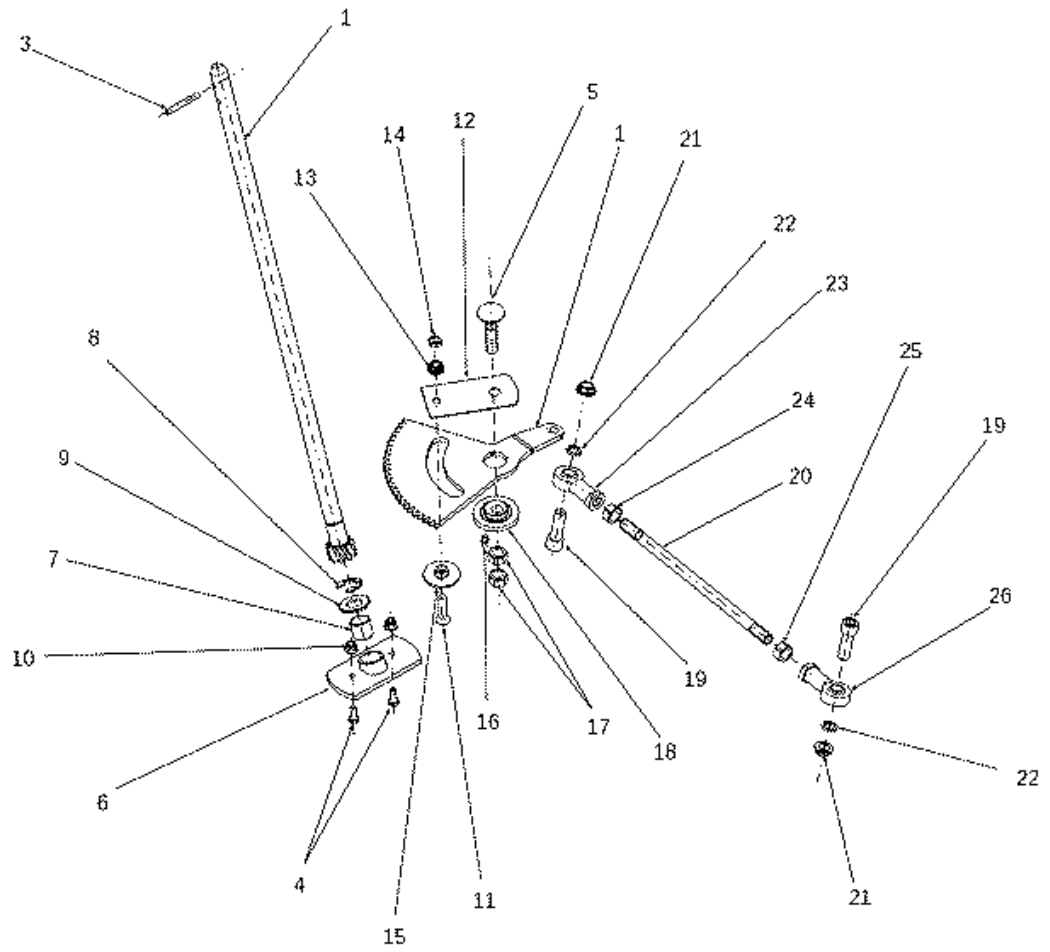

Illustration Lenkgetriebe

Bild Nr.	St.- Zahl	Teile Nr.	Beschreibung
1	1	68120021	Satz Ritzel und Zahnrad
3	1	SGN315238031	Stift
4	2	SGN309503548	Schraube
5	1	SGN309019522	Schraube
6	1	SG532938542043	Halter
7	1	SGN323721002	Lager
8	1	SGN311732008	Ring
9	1	SGN311210514	Scheibe
10	1	SGN311129525	Mutter
11	1	SGN309578534	Schraube
12	1	SGS53211332280	Platte
13	1	SGN311129520	Mutter
14	1	SGN311120520	Mutter
15	1	SGS53219520259	Distanzstück
16	1	SGN425111004	Fettnippel
17	2	SGN311150505	Mutter
18	1	SGS53208027203	Exzenter
19	2	SGN309543522	Schraube
20	1	SGN532980139	Welle
21	2	SGN311129521	Mutter
22	2	SGN311214504	Kugelscheibe
23	1	SGN442073028	Gehäuse
24	1	SGN311150505	Mutter
25	1	SGN311150516	Mutter
26	1	SGN442073029	Gehäuse

Illustration Riemenscheibe

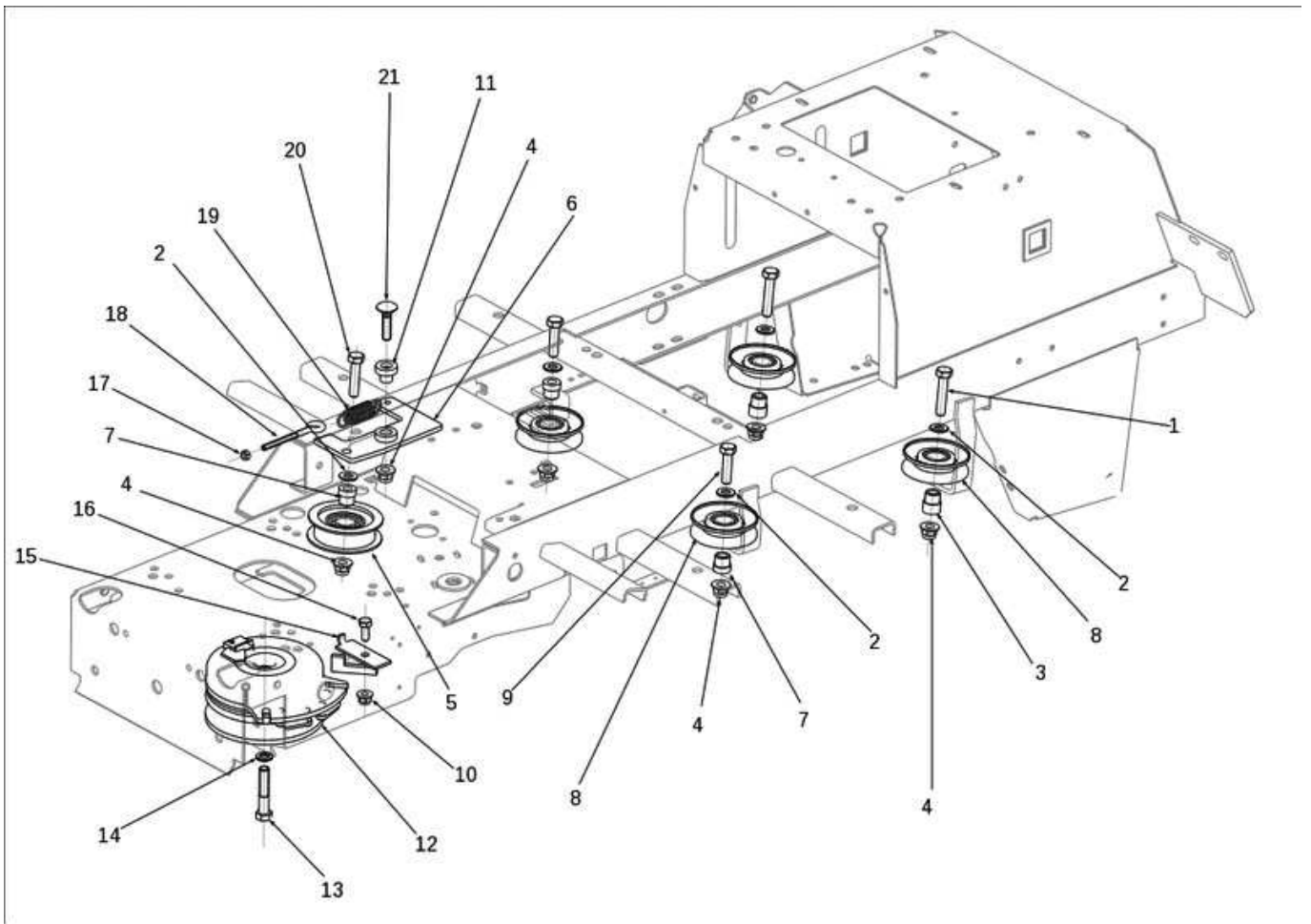

Illustration Riemenscheibe

Bild Nr.	St.- Zahl	Teile Nr.	Beschreibung
1	2	SGN309503526	Schraube
2	5	SGN311210504	Scheibe
3	2	SGN532150778	Buchse
4	6	SGN311129523	Mutter
5	1	SGN532150733	Riemenscheibe
6	1	SGS53291332276	Halter
7	3	SGN532150524	Buchse
8	4	SGN532150824	Riemenscheibe
9	2	SGN309501518	Schraube
10	1	SGN532150290	Mutter
11	1	SGN532150545	Buchse
12	1	SGN000532010	Kupplung
13	1	SGN309579509	Schraube
14	1	SGN311219516	Scheibe
15	1	SGS53293636216	Führung
16	1	SGN309503518	Schraube
17	1	SGN311129513	Sichermutter
18	1	SGN309578523	Schraube
19	1	SGN315231111	Zuendkerze
20	1	SGN309203544	Schraube
21	1	SGN309019529	Schraube

Illustration Getriebe

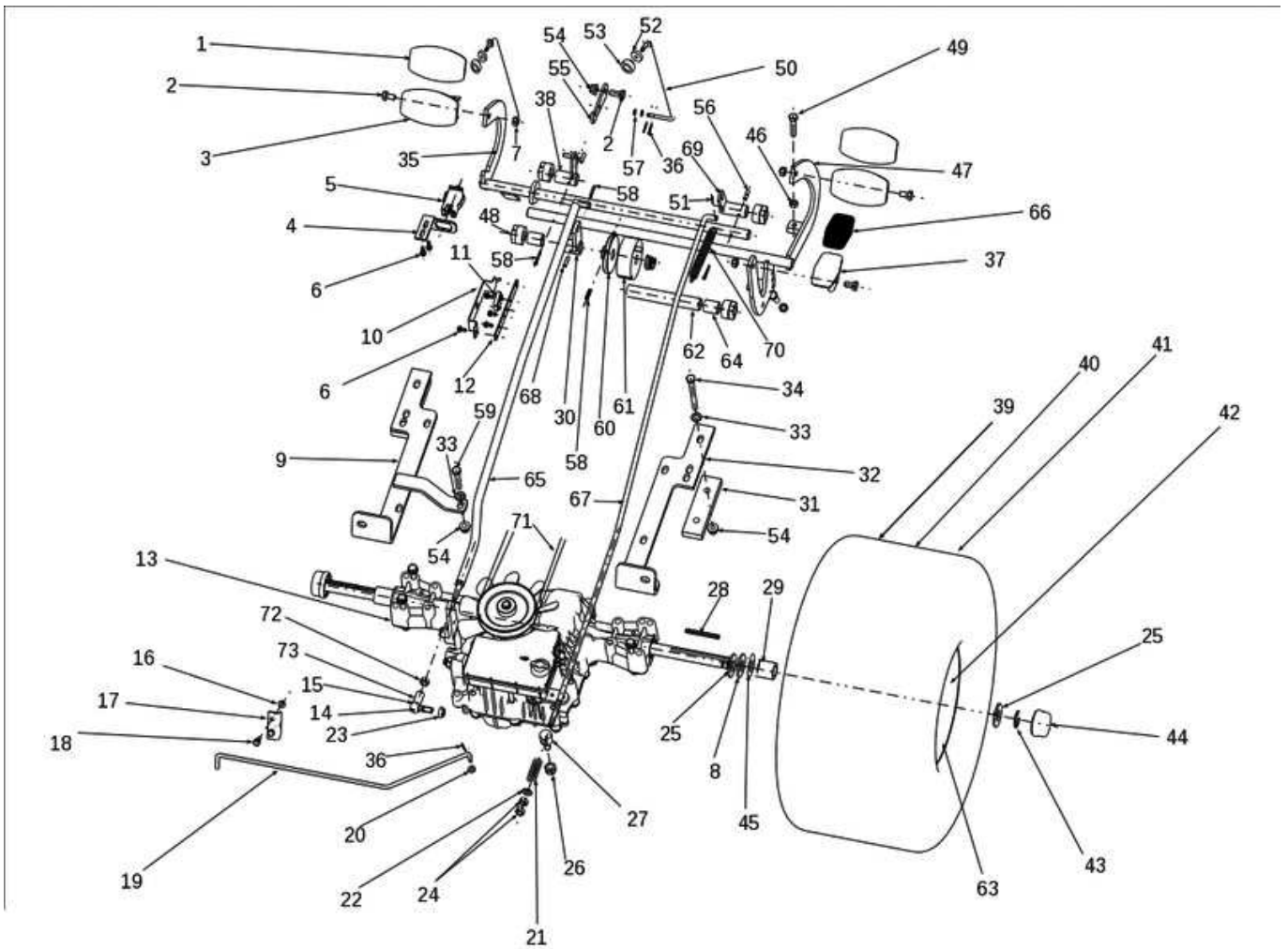

Illustration Getriebe

Bild Nr.	St.- Zahl	Teile Nr.	Beschreibung
1	2	SGN273151001	Deckung
2	4	SGN309503518	Schraube
3	2	SGS53298051257	Fusshebel
4	1	SGS53211340500	Halter
5	1	SGN532150994	Schalter
6	2	SGN309315012	Schraube
7	3	SGN311129501	Mutter
8	10	SGS53209220815	Scheibe
9	1	SGS53291336844	Halter
10	-	-	Nicht verfügbar für diesen produkt
11	-	-	Nicht verfügbar für diesen produkt
12	-	-	Nicht verfügbar für diesen produkt
13	1	SGN532991052	Antrieb K46
14	1	SGN442073018	Mutter
15	1	SGN442073017	Winkelstahl
16	2	SGN311129524	Mutter
17	1	SGS53211340391	Halter
18	2	SGN309203539	Schraube
19	1	SGN532150724	Hebel
20	1	SGN311210502	Scheibe
21	1	SGN315231240	Feder
22	1	SGN311212517	Scheibe
23	1	SGN311129520	Mutter
24	2	SGN311120520	Mutter
25	4	SG532092208363	Scheibe
26	1	SGN311129502	Mutter
27	1	SGN532150507	Schraube
28	2	SGS53209231216	Feder
29	2	SGN532150542	Distanzstück
30	1	SGS53298036482	Arm
31	2	SGS53209230394	Scheibe
32	1	SGS53211340386	Halter
33	5	SGN311210503	Scheibe
34	4	SGN309501571	Schraube
35	1	SGS53298044250	Bremsepedal
36	3	SGN311338513	Stift

Illustration Getriebe

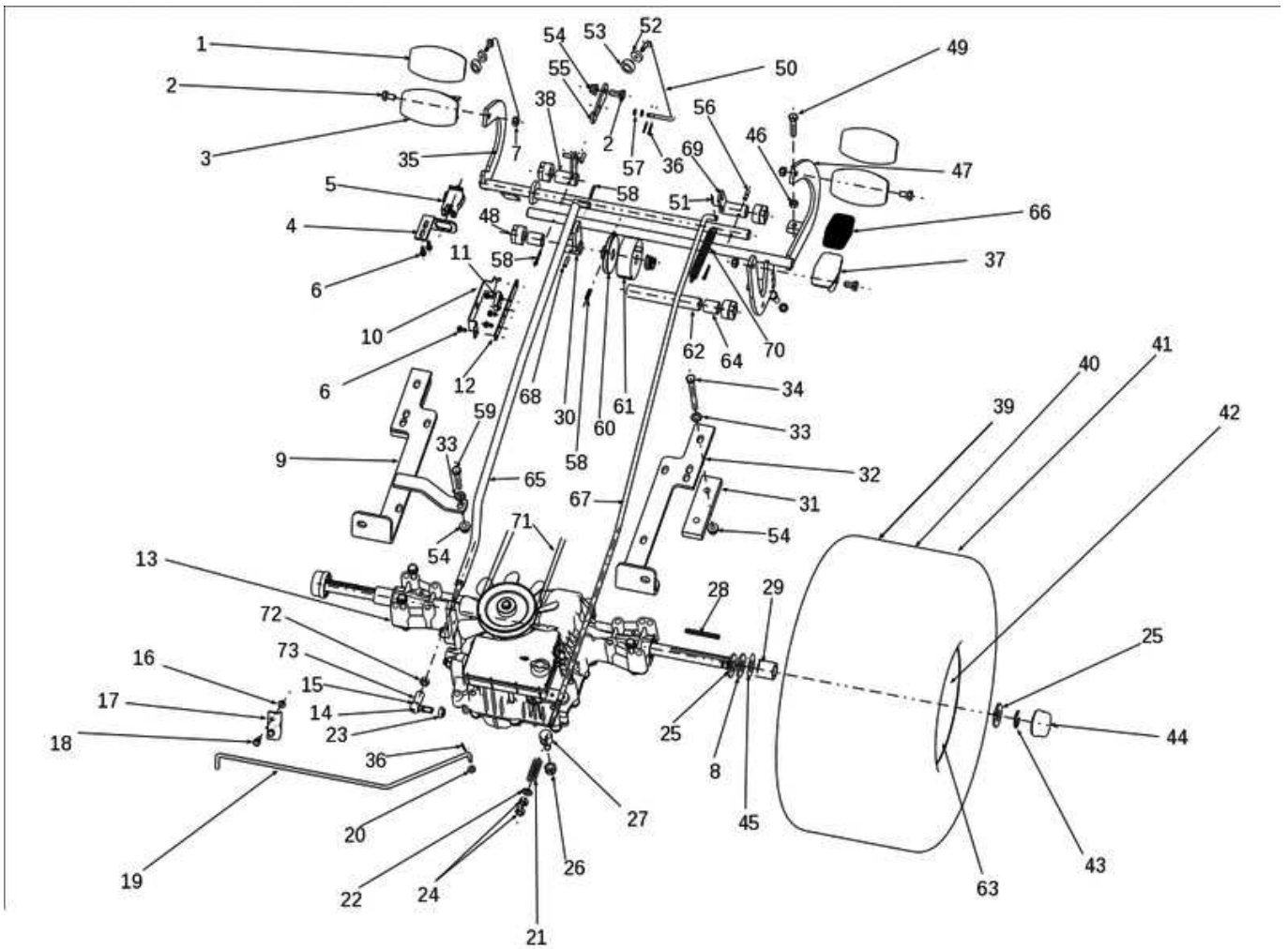

Illustration Getriebe

Bild Nr.	St.-Zahl	Teile Nr.	Beschreibung
37	1	SGS53298051258	Fusshebel
38	1	SGS53298036536	Verbindung
39	2	SGN532940135	Hinterrad
40	2	SGN274161024	Reifen
41	2	SGN000532133	Reifenschlauch
42	2	SGN000532134	Hinterrad
43	2	SGN311732023	Buchse
44	2	SGN532150915	Deckel
45	10	SGS53209220815	Scheibe
46	2	SGN311150503	Mutter
47	1	SGS53298044251	Hebel
48	4	SGN722643023	Buchse
49	2	SGN309503543	Schraube
50	1	SGN532980140	Bremse
51	1	SGN311338516	Stift
52	1	SGN273192027	Scheibe
53	1	SGN532150993	Scheibe
54	6	SGN532150290	Mutter
55	1	SGS53203732223	Haken
56	2	SGN315238050	Stift
57	2	SGN311210501	Scheibe
58	3	SGN311338517	Stift
59	1	SGN309503559	Schraube
60	-		Nicht verfügbar für diesen produkt
61	-		Nicht verfügbar für diesen produkt
62	-		Nicht verfügbar für diesen produkt
63	2	SGN000532135	Ventil
64	2	SGN532150541	Buchse
65	1	SGN532150725	Spannstange
66	1	SGN273151011	Deckung
67	1	SGN532151121	Pleuel
68	1	SGN315238037	Stift
69	1	SG532980365183	Kupplungsblock
70	1	SGN315231161	Zuendkerze
71	1	SGN272731202	Riemen 13x2600
72	1	SGN311150503	Mutter
73	1	SGN442073016	Buchse

Illustration Mäheraushebung-schaltung

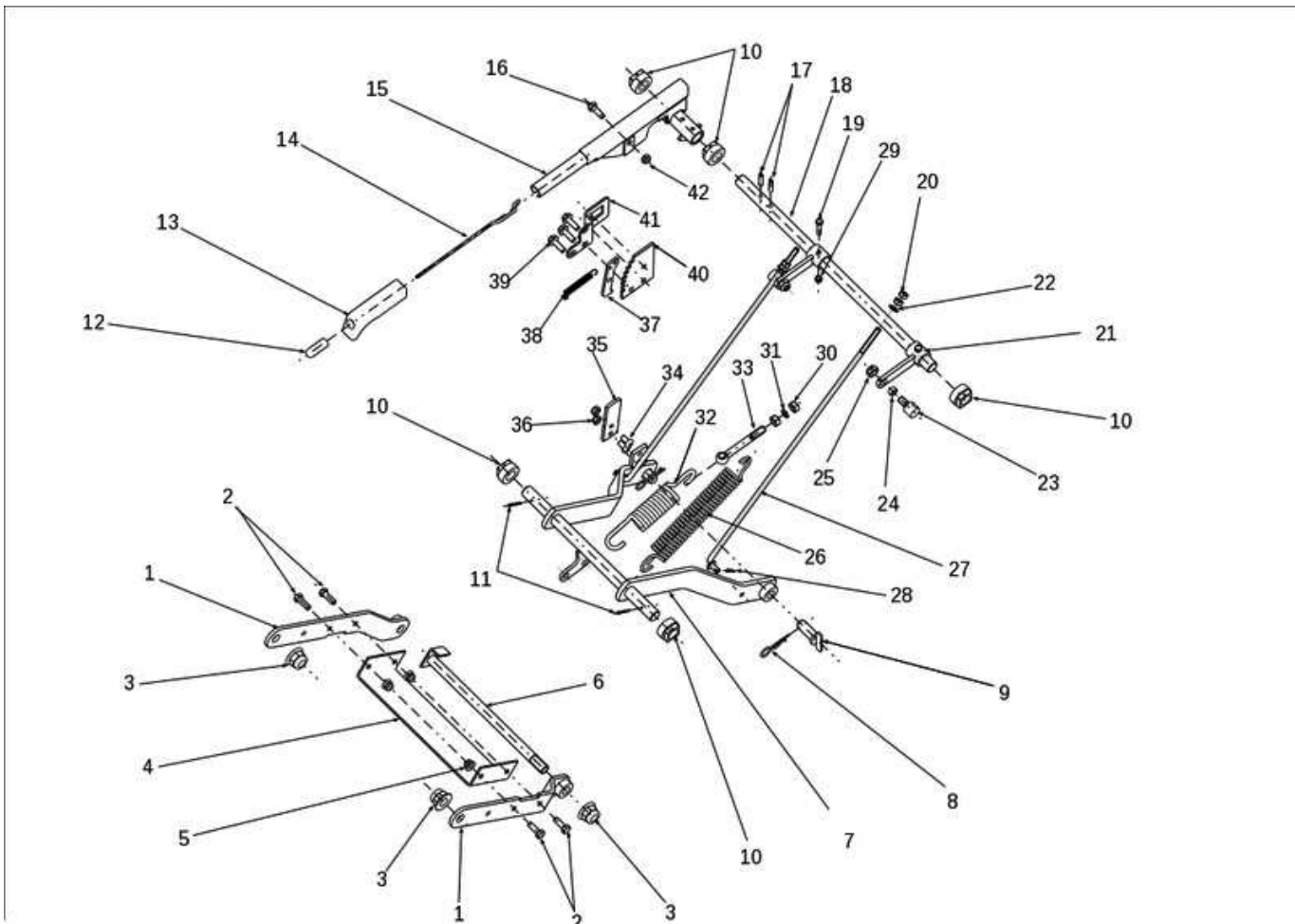

Illustration Mäheraushebung-schaltung

Bild Nr.	St.- Zahl	Teile Nr.	Beschreibung
1	2	SGS53298050822	Harm
2	4	SGN309503512	Schraube
3	3	SGN311129527	Mutter
4	1	SGS53208050367	Halter
5	4	SGN532150290	Mutter
6	1	SGS53293812253	Welle
7	1	SGS53298050820	Hubharm
8	2	SGN315238003	Splint
9	2	SG532993462343	Stift
10	5	SGN722643022	Buchse
11	2	SGN311338517	Stift
12	1	SG722643016	Toranschluss
13	1	SGN532150049	Handgriff
14	1	SGN315238034	Stange
15	1	SG532980522163	Hebel
16	1	SGN309503512	Schraube
17	2	SGN315238041	Stift
18	1	SGS53203810285	Welle
19	2	SGN309501568	Schraube
20	4	SGN311150503	Mutter
21	2	SGS53298046285	Komplett arm
22	2	SGN311210503	Scheibe
23	2	SGN532150507	Schraube
24	2	SGN532150729	Mutter
25	2	SGN311129502	Mutter
26	1	SGN315231193	Feder
27	2	SGN532980141	Spannstange
28	2	SGN311338516	Stift
29	2	SGN311129513	Sichermutter
30	2	SGN311150506	Mutter
31	1	SGN311214503	Scheibe
32	1	SGN315231165	Feder
33	1	SGN309510001	Schraube
34	2	SGN309578522	Schraube
35	1	SGS53211432722	Kupplungsblock
36	2	SGN311129501	Mutter
37	1	SGS53203732211	Platte
38	1	SGN315231158	Feder

Illustration Mäheraushebung-schaltung

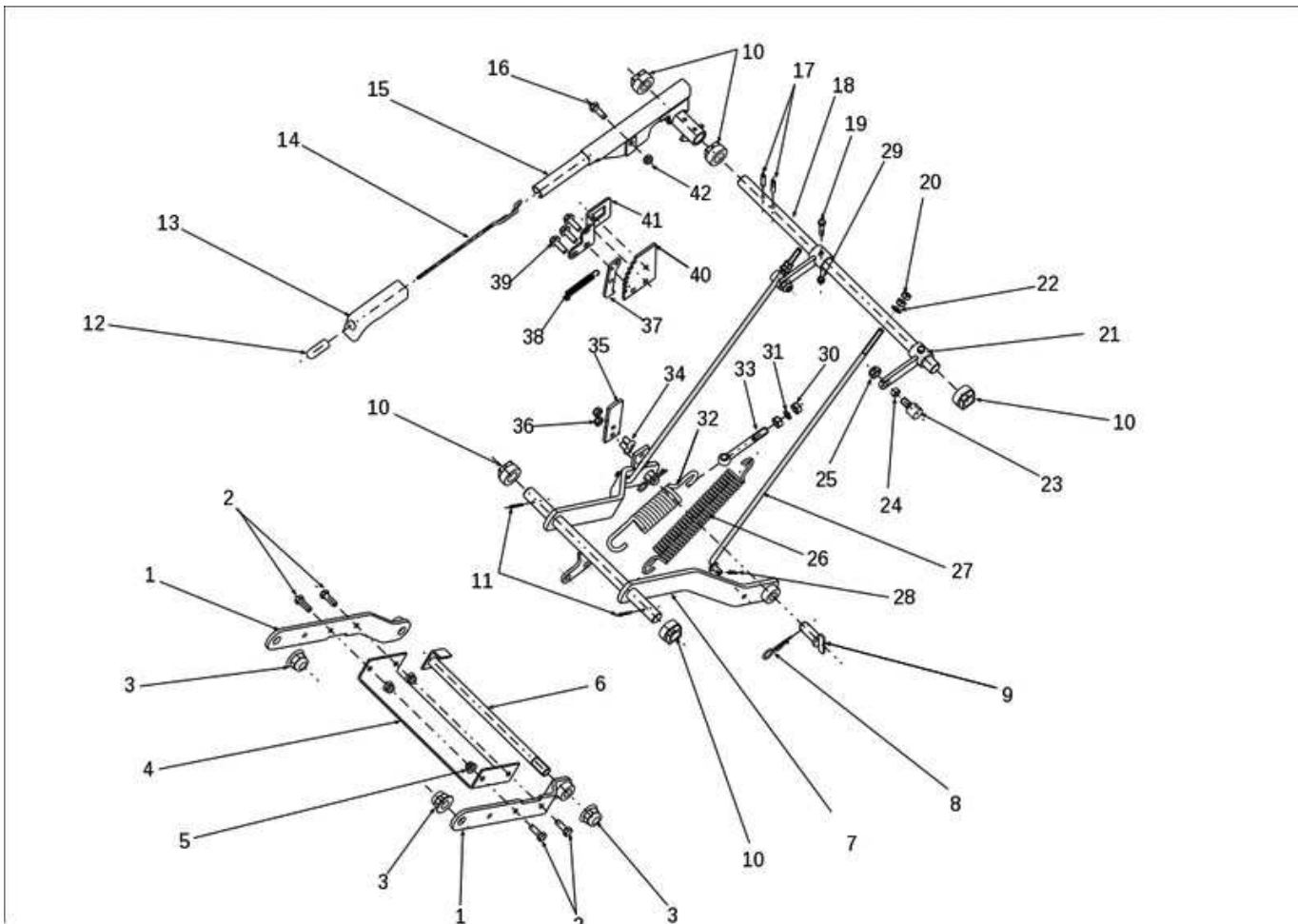

Illustration Mäheraushebung-schaltung

Bild Nr.	St.- Zahl	Teile Nr.	Beschreibung
39	3	SGN309503005	Schraube
40	1	SG532037322183	Zahnrad
41	1	SG532113414183	Halter
42	1	SGN311129501	Mutter

Illustration Schneidwerkzeug (1/3)

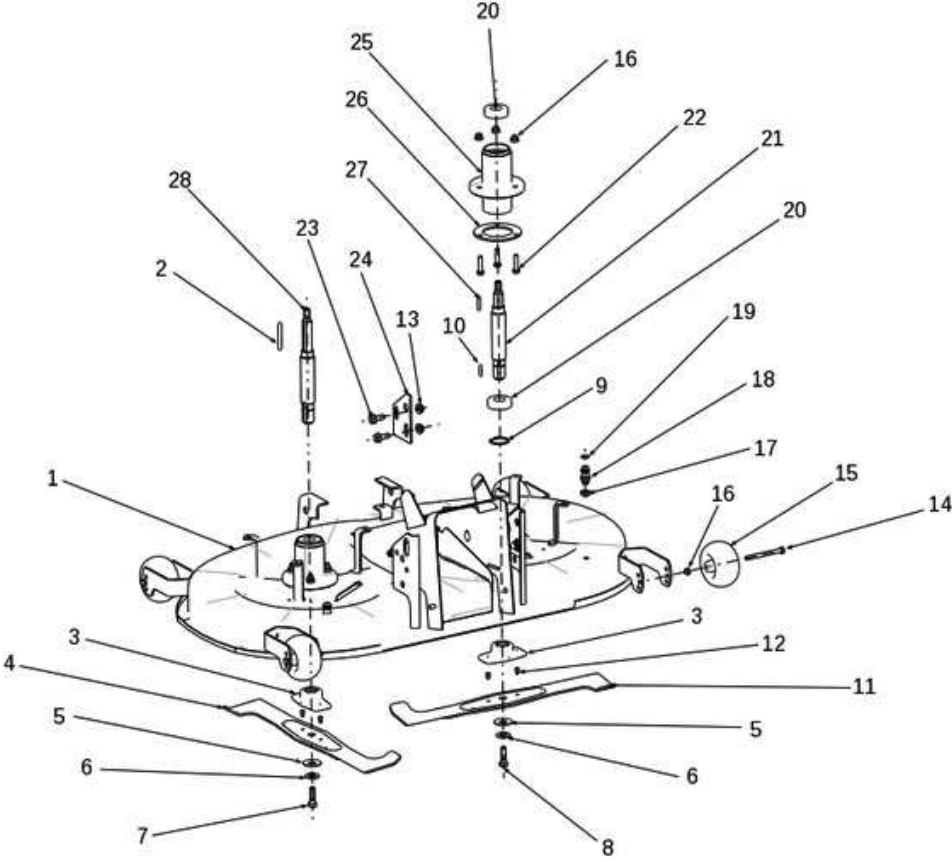

Illustration Schneidwerkzeug (1/3)

Bild Nr.	St.- Zahl	Teile Nr.	Beschreibung
1	1	SGS53295047226	Messerdeckel
2	1	SGN311726086	Feder
3	2	SG532098212403	Anpassungsglied
4	1	SG532050422533	Messer mulching
4	1	SG532050422473	Blatt SX; LEFT
5	2	SGN311219503	Kugelscheibe
6	2	SGN532150519	Kugelscheibe
7	1	SGN309599017	Schraube
8	1	SGN309599008	Schraube
9	2	SGN311733014	Sicherungsring
10	2	SGN311726091	Feder
11	1	SG532050422543	Messer mulching
11	1	SG532050422483	Blatt DX; RIGHT
12	4	SGN532980077	Stiftschraube
13	4	SGN311129522	Mutter
14	4	SGN309501567	Schraube
15	4	SGN532940128	Rad
16	10	SGN532150290	Mutter
17	2	SGN311120511	Mutter
18	2	SGN532150533	Schnellanschluss
19	2	SGN273111057	Ring
20	4	SGN324162099	Lager
21	1	SG532038128023	Welle
22	6	SGN309503543	Schraube
23	4	SGN309578529	Schraube
24	2	SGS53211330891	Buchse
25	2	SGS53203852383	Deckel
26	2	SGS53209820337	Dichtung
27	1	SGN311726091	Feder
28	1	SG532038128033	Welle

Illustration Schneidwerkzeug (2/3)

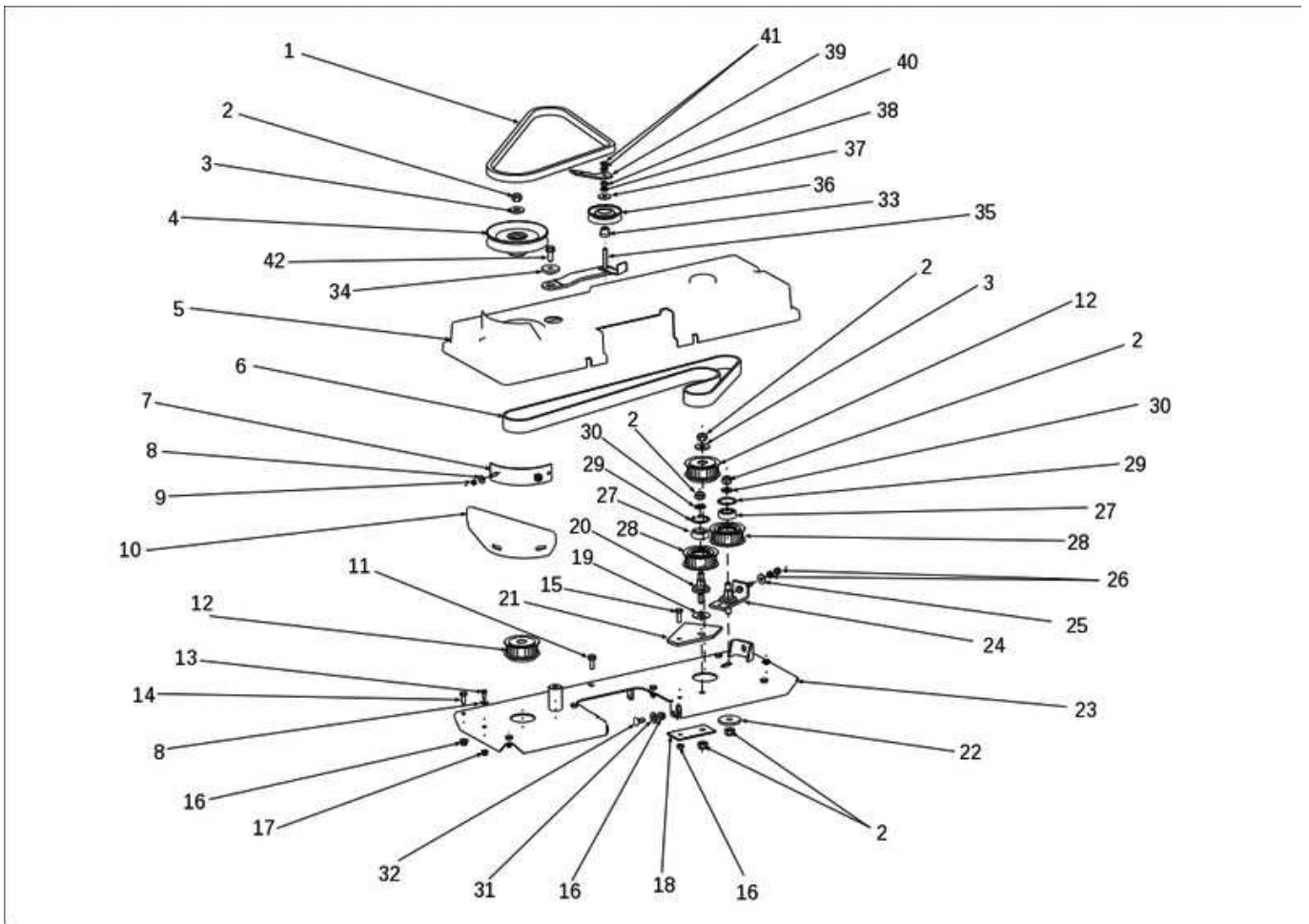

Illustration Schneidwerkzeug (2/3)

Bild Nr.	St.- Zahl	Teile Nr.	Beschreibung
1	1	SGN272731212	Riemen
2	5	SGN311129505	Mutter
3	2	SGS53209220727	Scheibe
4	1	SGN532150165	Riemenscheibe
5	1	SGN532150865	Deckel
6	1	SGN272211006	Riemen
7	1	SGS53298540273	Dichtung
8	4	SGN311212516	Scheibe
9	2	SGN311129513	Sichermutter
10	1	SGN532150559	Deckel
11	1	SGN309503005	Schraube
12	2	SGN532150860	Riemenscheibe
13	2	SGN309503508	Schraube
14	6	SGN309503518	Schraube
15	1	SGN309503512	Schraube
16	9	SGN532150290	Mutter
17	2	SGN311129525	Mutter
18	1	SGS53209230396	Halter
19	1	SGS53209220770	Scheibe
20	1	SGN532150806	Stiftschraube
21	1	SGS53209630397	Halter
22	1	SGS53209220753	Scheibe
23	1	SGS53298542346	Hauptplatte
24	1	SGS53291441231	Mutter
25	1	SGN311212517	Scheibe
26	2	SGN311150503	Mutter
27	4	SGN324162098	Lager
28	2	SGN532150836	Riemenscheibe
29	2	SGN311733079	Sicherungsring
30	2	SGN311210505	Scheibe
31	2	SGN311210505	Scheibe
32	2	SGN309019501	Schraube
33	1	SGS53209321263	Bolzen
34	1	SGN532150736	Scheibe
35	1	SGS53291342240	Halter komplett
36	1	SGN532150784	Kompensator

Illustration Schneidwerkzeug (2/3)

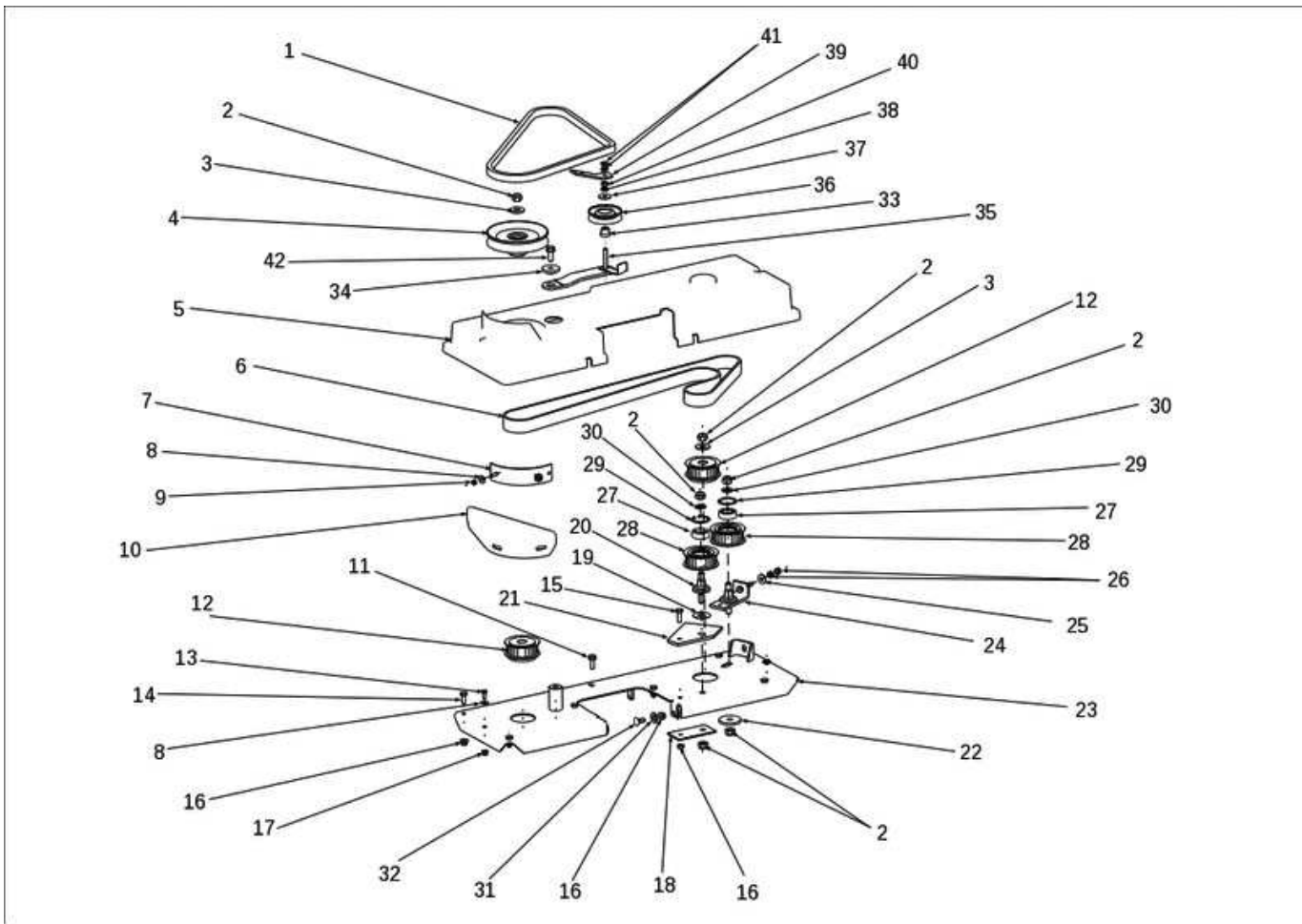

Illustration Schneidwerkzeug (2/3)

Bild Nr.	St.- Zahl	Teile Nr.	Beschreibung
37	1	SGN311212508	Scheibe
38	1	SGN311214502	Scheibe
39	1	SGS53211340235	Hebel
40	1	SGN311150503	Mutter
41	2	SGN311120520	Mutter
42	1	SGN309578529	Schraube

Illustration Schneidwerkzeug (3/3)

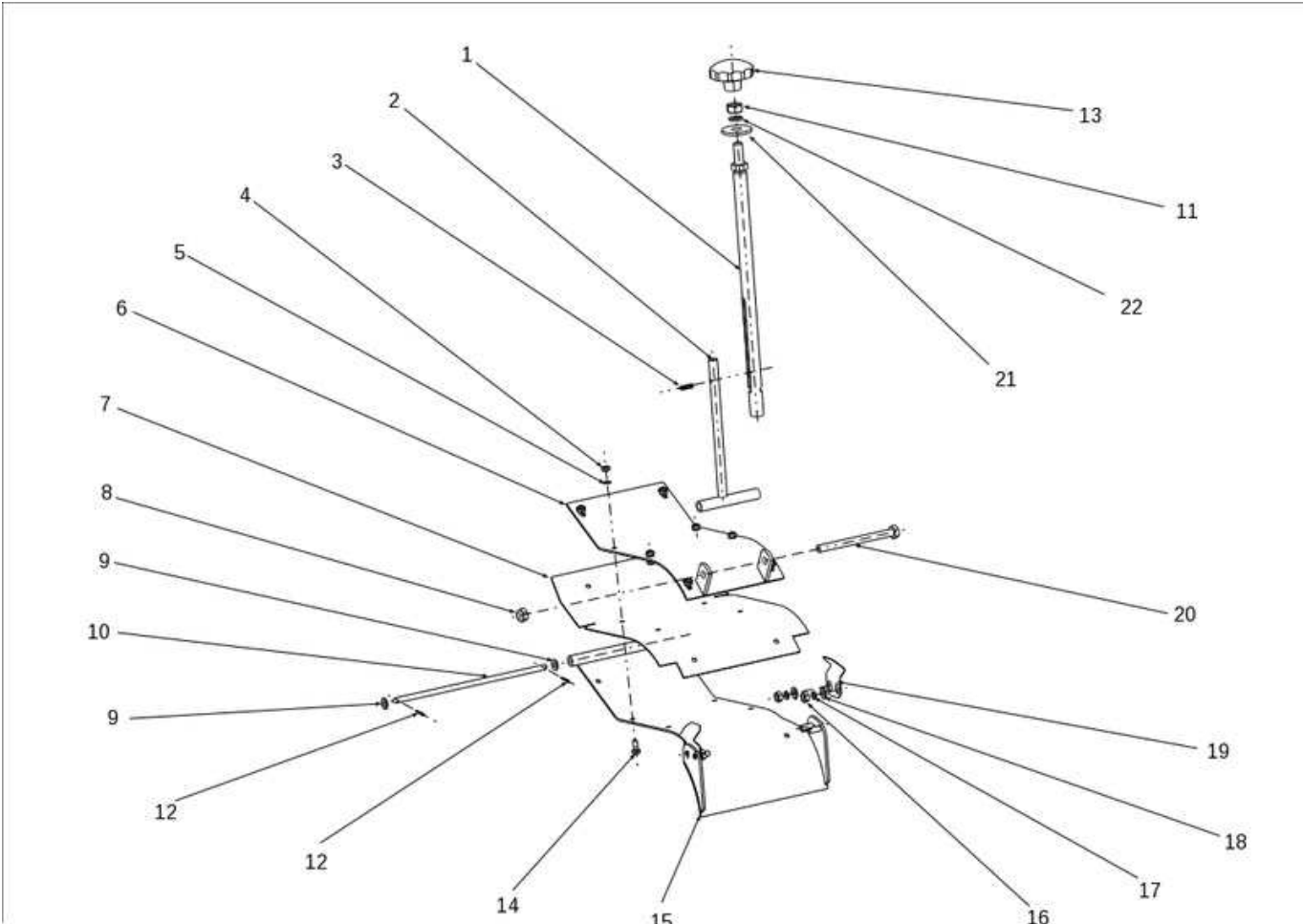

Illustration Schneidwerkzeug (3/3)

Bild Nr.	St.- Zahl	Teile Nr.	Beschreibung
1	1	SGS53291321207	Halter
2	1	SGS53298032218	Halter
3	1	SGN315238053	Stift
4	8	SGN311129515	Mutter
5	8	SGN311210501	Scheibe
6	1	SGS53291332293	Halter
7	1	SGN273192013	Deckel
8	1	SGN311129501	Mutter
9	2	SGN311210502	Scheibe
10	1	SGS53203810293	Stange
11	1	SGN311150506	Mutter
12	2	SGN311338513	Stift
13	1	SGN532150673	Bedienungsstern
14	8	SGN309203548	Schraube
15	1	SGS53298042214	Rolle
16	4	SGN311150504	Mutter
17	4	SGN311214501	Scheibe
18	4	SGN311210502	Scheibe
19	2	SGS53209742231	Feder
20	1	SGN309201522	Schraube
21	1	SGN311212507	Scheibe
22	1	SGN311214503	Scheibe

Illustration Auswurf-träger fangkorb

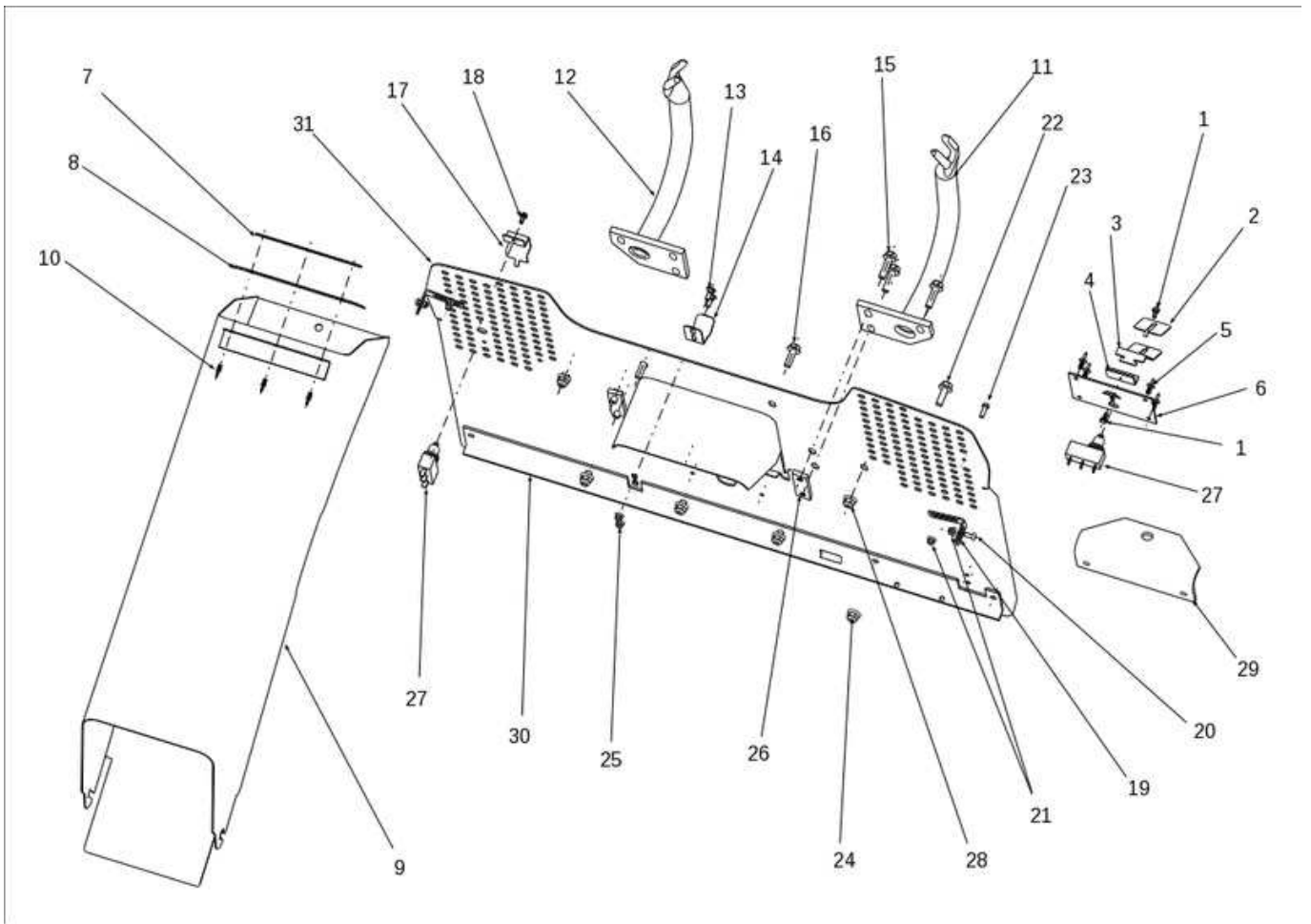

Illustration Auswurf-träger fangkorb

Bild Nr.	St.- Zahl	Teile Nr.	Beschreibung
1	2	SGN309315012	Schraube
2	1	SGS53201441474	Plattform
3	1	SGS53201441473	Plattform
4	1	SGS53211340468	Halter
5	4	SGN532150984	Niete
6	1	SGS53211430788	Plattform
7	1	SGS53211530857	Scheibe
8	1	SGN273192015	Deckel
9	1	SGS53297447268	Tunnel
10	3	SGN532151003	Niete
11	1	SGS53297443216	Halter
12	1	SGS53297443217	Halter
13	2	SGN309019514	Schraube
14	1	SGS53209746499	Feder
15	6	SGN309578012	Schraube
16	2	SGN309503005	Schraube
17	1	SGN273151001	Deckung
18	1	SGN309315011	Schraube
19	2	SGS53201440890	Halter
20	2	SGN309578532	Schraube
21	4	SGN311129524	Mutter
22	4	SGN309578011	Schraube
23	2	SGN309203539	Schraube
24	4	SGN532150290	Mutter
25	2	SGN311129524	Mutter
26	2	SGS53221530201	Verstaerkung
27	2	SGN345359004	Schalter korb 2008/09/10
28	2	SGN532150290	Mutter
29	1	SGN532150296	Aufhängung
30	1	SGS53211340323	Halter
31	1	SGS53297442222	Panel

Illustration Grasfangkorb

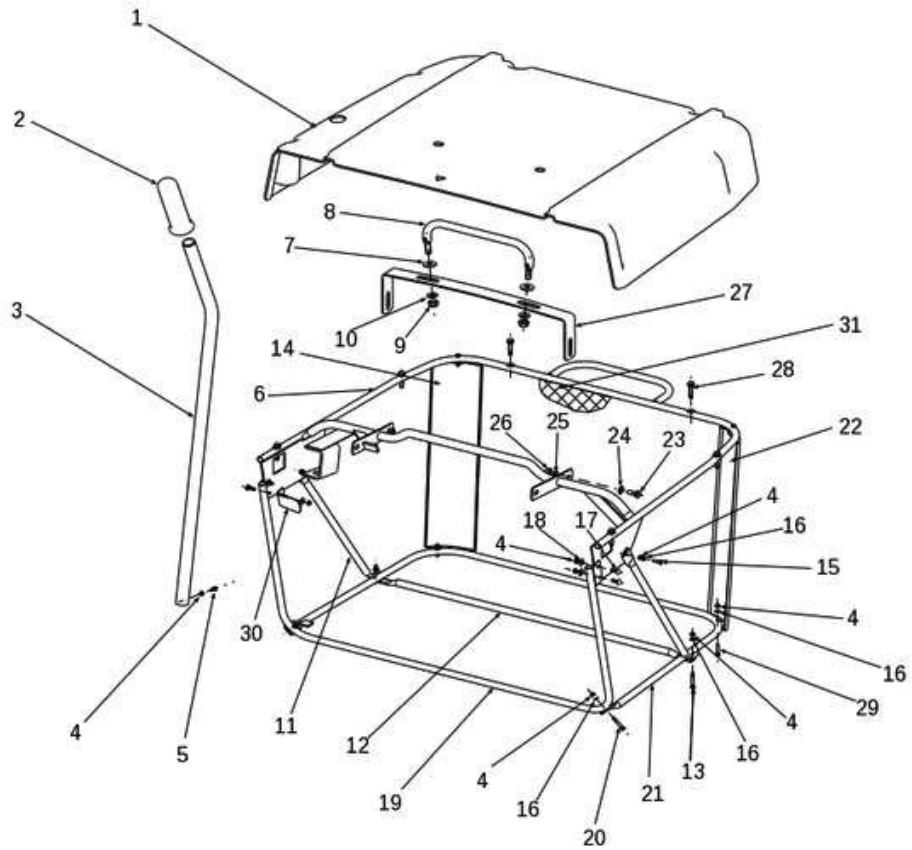

Illustration Grasfangkorb

Bild Nr.	St.- Zahl	Teile Nr.	Beschreibung
1	1	SGN532150864	Deckel
1	1	SGN532151008	Deckel orange
2	1	SGN532150007	Handgriff
3	1	SGN532150701	Hebel
4	15	SGN311129515	Mutter
5	1	SGN309203548	Schraube
6	1	SGS53297447229	Oberer rahmen
7	2	SGN311210504	Scheibe
8	1	SGS53291346325	Handgriff
9	2	SGN311129502	Mutter
10	2	SGN311212521	Scheibe
11	1	SG532074262023	Rahmen
12	1	SGS53207426201	Rohr
13	2	SGN309203556	Schraube
14	1	SGN532150699	Verstaerkung
15	2	SGN309203539	Schraube
16	10	SGN311210501	Scheibe
17	4	SGN309019514	Schraube
18	4	SGN311212514	Scheibe
19	1	SGN532150694	Rohr
20	2	SGN309203555	Schraube
21	1	SGN532150696	Rohr
22	1	SGS53207442227	Verstaerkung
23	2	SGN309503518	Schraube
24	2	SGN311210503	Scheibe
25	2	SGN311214502	Scheibe
26	2	SGN311120502	Mutter
27	1	SGN532151040	Verstaerkung
28	6	SGN309315013	Schraube
29	4	SGN309203557	Schraube
30	1	SGS53209740223	Zuendkerze
31	1	SGN532150135	Ersatzsack

Illustration Kapotte (1/3)

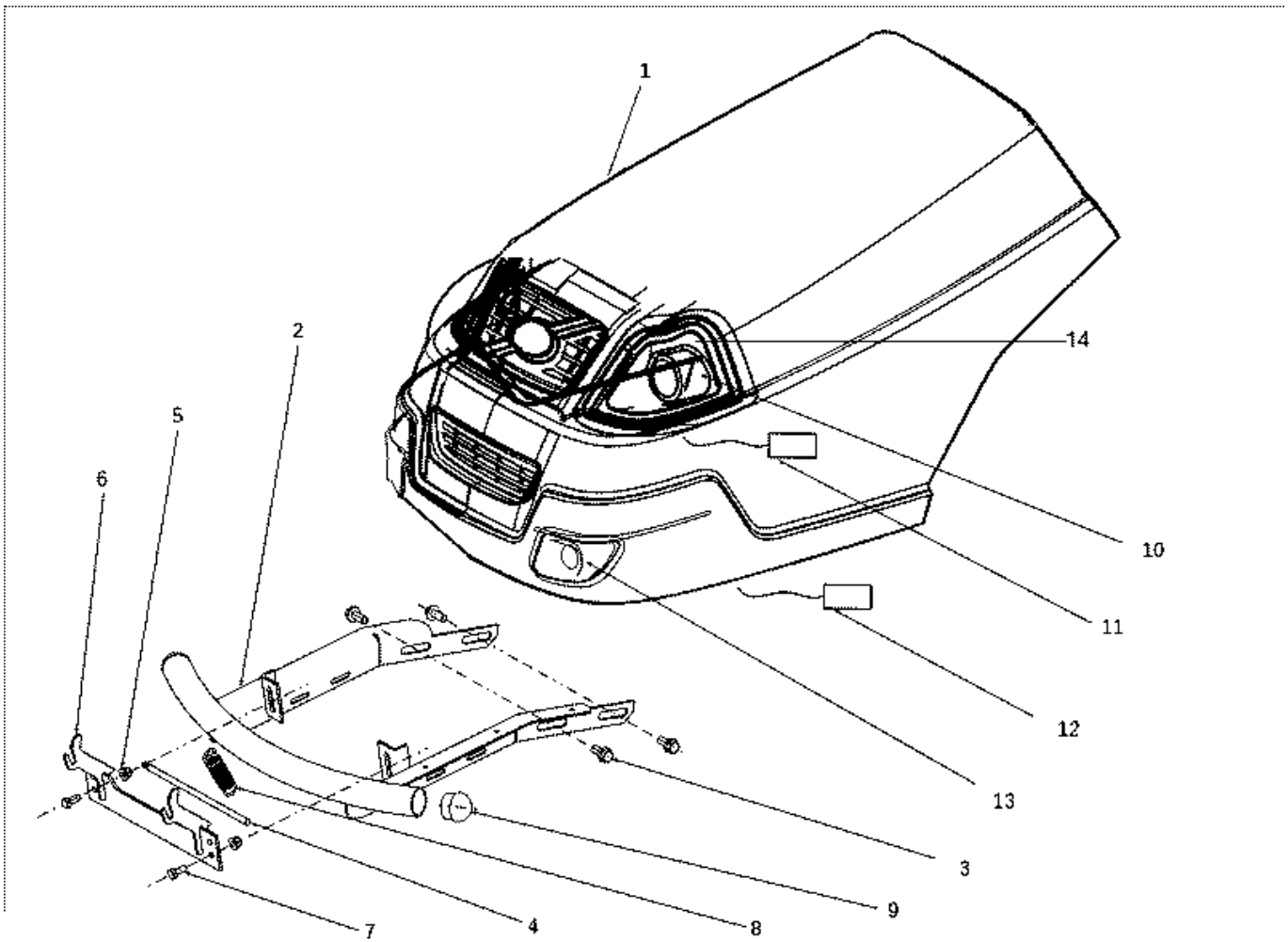

Illustration Kapotte (1/3)

Bild Nr.	St.- Zahl	Teile Nr.	Beschreibung
1	1	SGN532151006	Kofferraum
1	1	SGN532151068	Kapotte
2	1	SGS53291845210	Stossstangen
3	4	SGN309578529	Schraube
4	1	SGS53201310214	Sicherungsstange
5	2	SGN532150290	Mutter
6	1	SGS53291340312	Halter
7	2	SGN309503512	Schraube
8	1	SGN315231203	Feder
9	2	SGN321841087	Verschluss
10	2	SGN347411002	Glühlampe
11	2	SGN443953007	Kabel (Lampenhalter)
12		-	Nicht verfügbar für diesen produkt
13		-	Nicht verfügbar für diesen produkt
14	1	SGN532151054	Blende (Deckung)

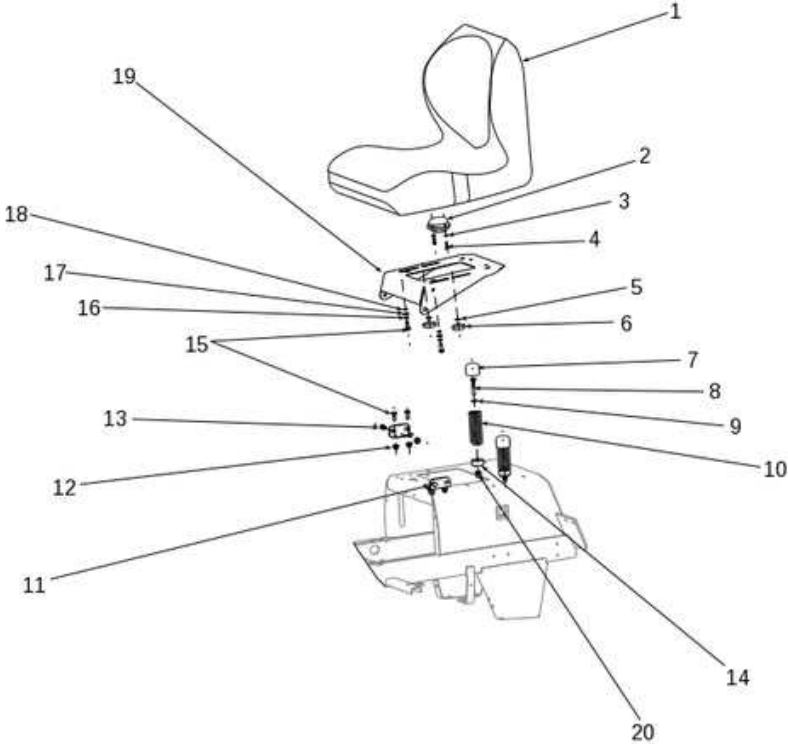

Illustration Kapotte (2/3)

Bild Nr.	St.- Zahl	Teile Nr.	Beschreibung
1	1	SGN532150891	Sitz
2	1	SGN345359005	Schalter
3	2	SGN311212515	Scheibe
4	2	SGN309315015	Schraube
5	2	SGN311213503	Scheibe
6	2	SGN532150213	Mutter
7	2	SG532150208	Stopfen
8	2	SGN309503559	Schraube
9	2	SGN311212517	Scheibe
10	2	SGN315231124	Feder
11	2	SGS53211340240	Halter
12	6	SGN532150290	Mutter
13	2	SGN309599012	Schraube
14	2	SGN532150992	Distanzstuck
15	6	SGN309503518	Schraube
16	2	SGN311210503	Scheibe
17	2	SGN311214502	Scheibe
18	2	SGN311219002	Scheibe
19	1	SGS53201847243	Sitz
20	2	SGN311129501	Mutter

Illustration Kapotte (3/3)

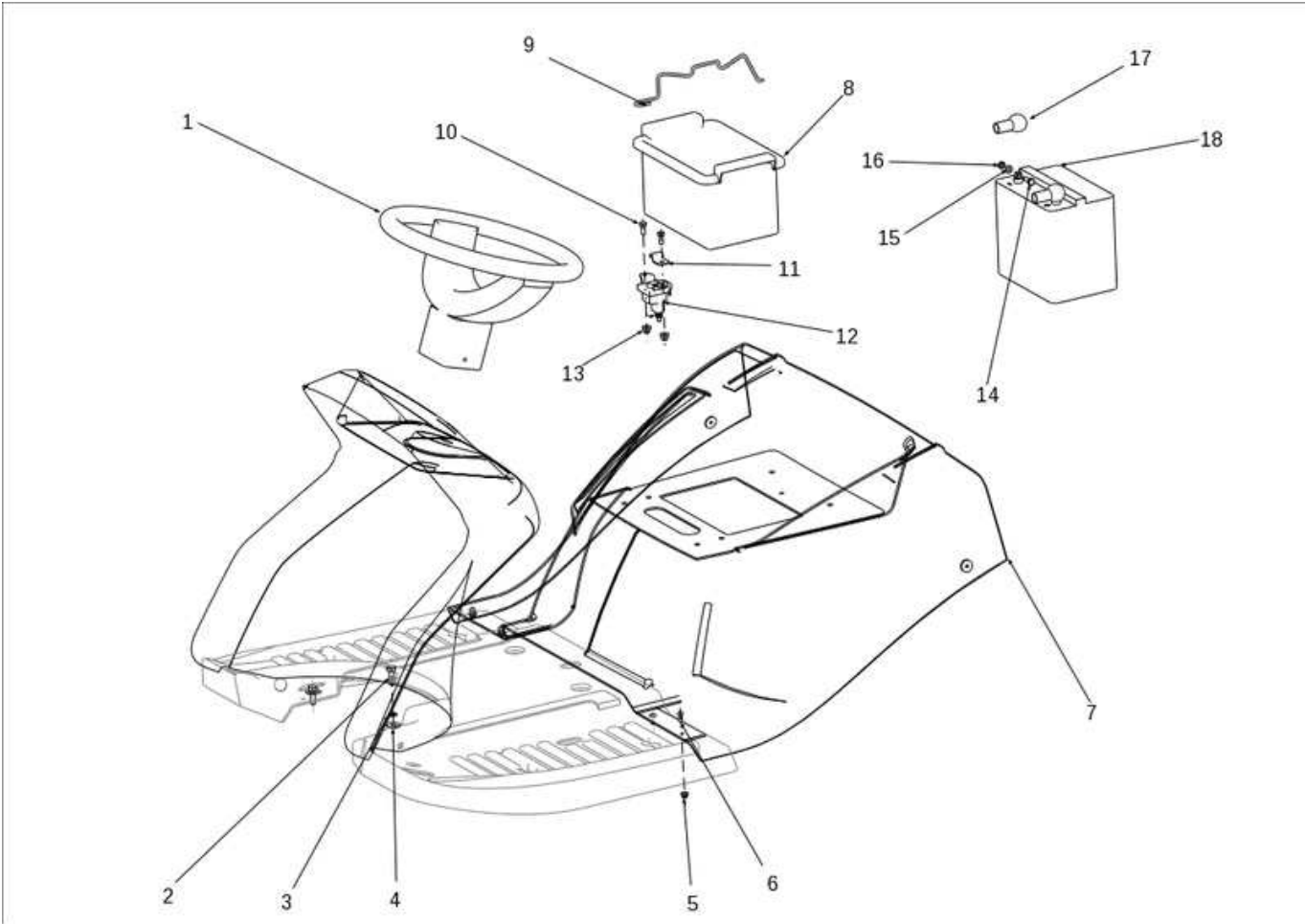

Illustration Kapotte (3/3)

Bild Nr.	St.- Zahl	Teile Nr.	Beschreibung
1	1	SG443821004R	Lenkrad
2	2	SGN309503512	Schraube
3	2	SGN311212517	Scheibe
4	2	SGN311214502	Scheibe
5	4	SGN311129524	Mutter
6	4	SGN309578532	Schraube
7	1	SGN532150859	Rahmen
7	1	SGN532151009	Chassis orange
8	1	SGN232130001	Batteriefach
9	1	SGN532880041	Halter
10	2	SGN309503508	Schraube
11	1	SGS53211341345	Ring
12	1	SGN000532033	Solenoid
13	2	SGN311129525	Mutter
14	2	SGN309503548	Schraube
15	2	SGN311210502	Scheibe
16	2	SGN311129513	Sichermutter
17	2	SGN273125006	Deckel
18	1	SGN346211006	Batterie

Illustration Stirwand

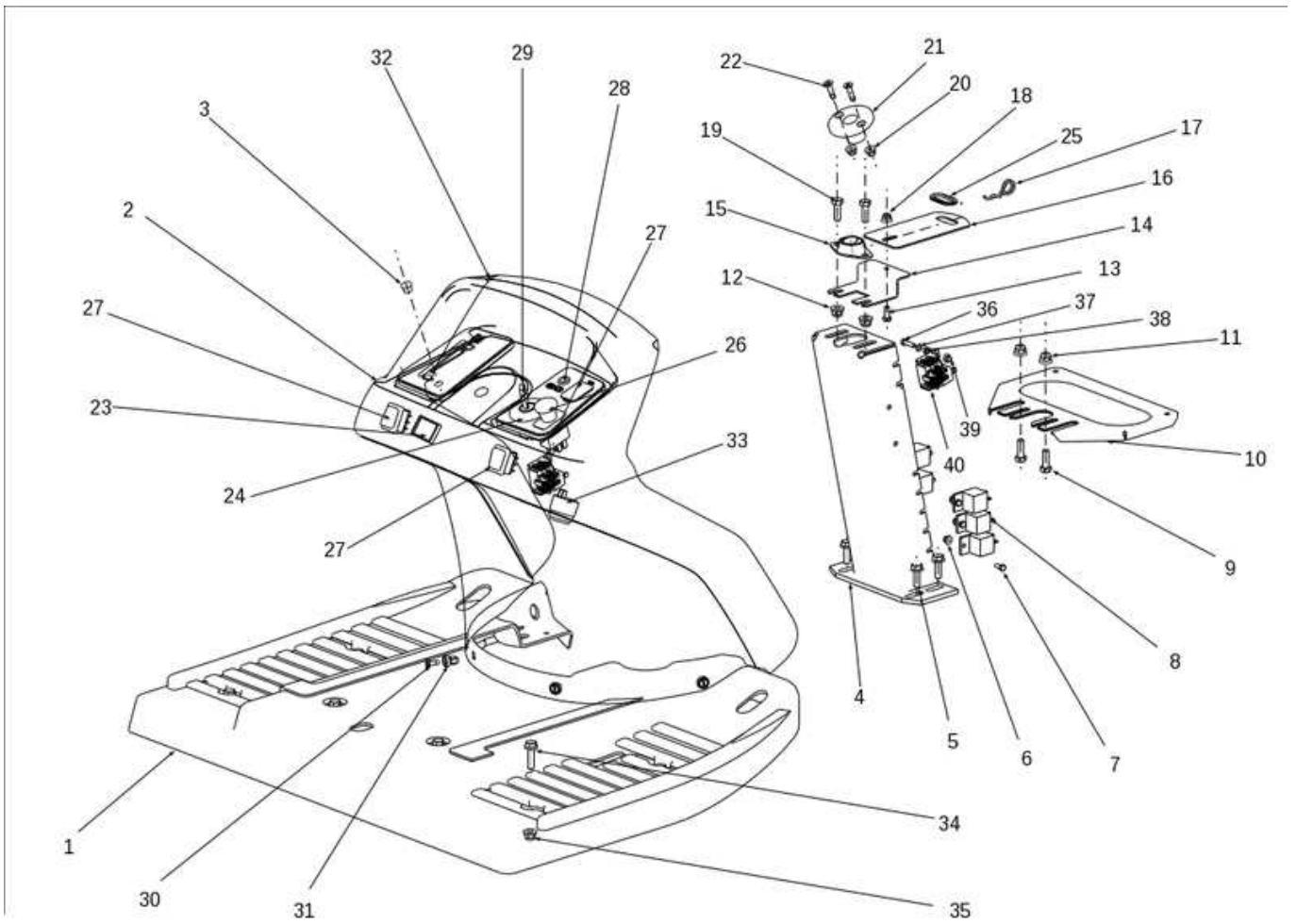

Illustration Stirnwand

Bild Nr.	St.- Zahl	Teile Nr.	Beschreibung
1	1	SGN532150950	Boden
2	1	SGN532150986	Panel
3	1	SGN321841082	Stopfen
4	1	SGS53291642205	Spurstange
5	4	SGN309503005	Schraube
6	4	SGN311129524	Mutter
7	4	SGN309203548	Schraube
8	4	SGN443811004	Relais
9	2	SGN309503512	Schraube
10	1	SGS53298342202	Halter
11	2	SGN532150290	Mutter
12	2	SGN532150290	Mutter
13	1	SGN309503508	Schraube
14	1	SGS53211341486	Halter
15	1	SGN000324001	Lager
16	1	SGS53211340469	Halter
17	1	SGN315238005	Stift
18	1	SGN311129525	Mutter
19	1	SGN309503512	Schraube
20	2	SGN311129525	Mutter
21	1	SGN321841069	Buchse
22	2	SGN309578503	Schraube
23	1	SGN443433003	Schalter
24	1	SGN443861007	Schaltschrank
25	1	SGN273121027	Buchse
26	1	SGN345329022	Schalter
27	3	SGN321841085	Schluss
28	1	SGN443312022	Warnlicht
29	1	SGN443900137	Schlüssel
30	4	SGN532150904	Schraube
31	4	SGN532150903	Buchse
32	1	SGS53209634216	Saum
33	1	SG443312021	Sperre
34	6	SGN309578012	Schraube
35	6	SGN532150290	Mutter
36	2	SGN309203567	Schraube
37	2	SGN311210501	Scheibe
38	2	SGN311150515	Mutter
39	2	SGN311129524	Mutter
40	1	SGN341271151	Kabel

Illustration Tank

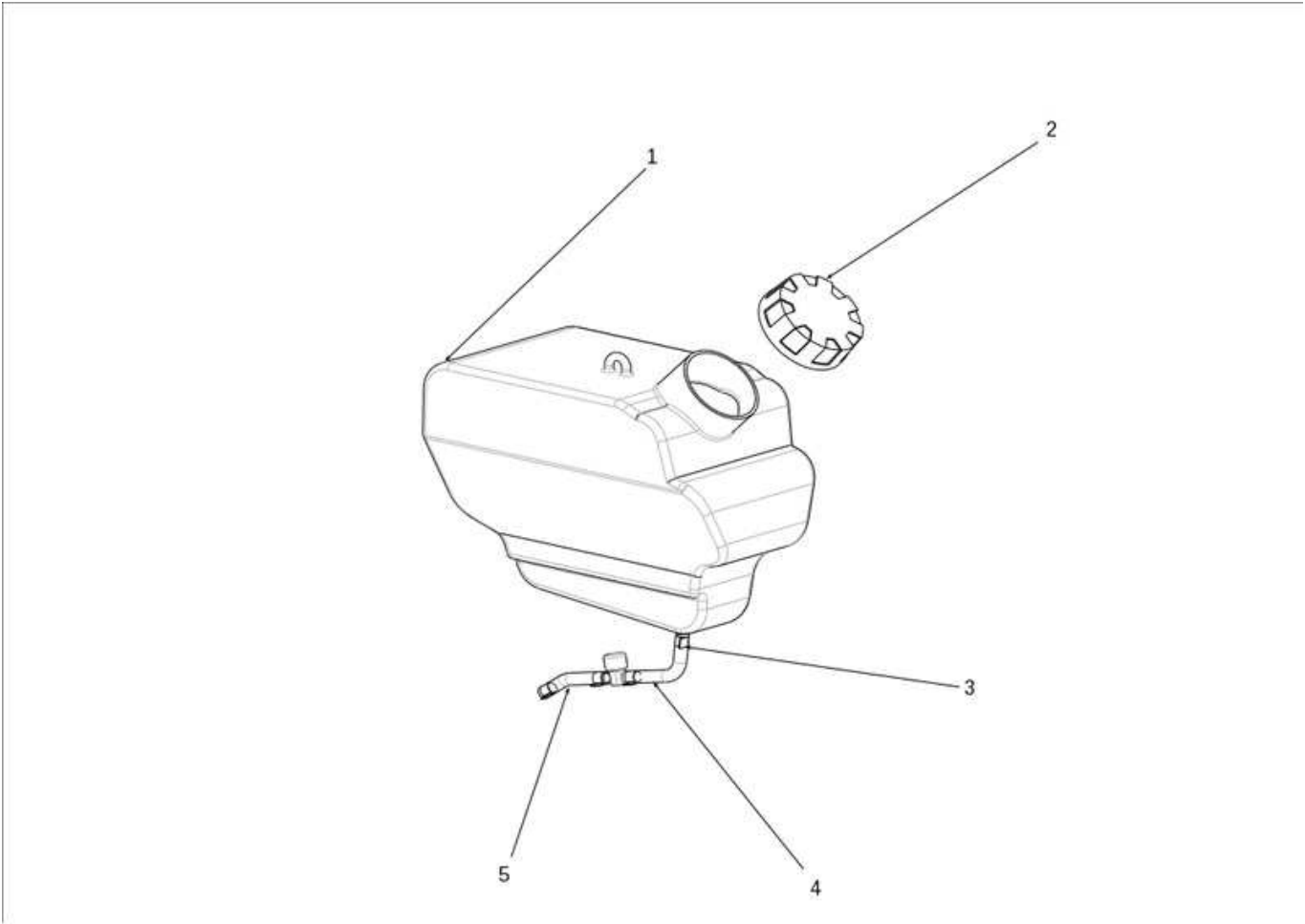

Illustration Tank

Bild Nr.	St.- Zahl	Teile Nr.	Beschreibung
1	1	SG532027662043	Tank
2	1	SGN321841017	Stopfen
3	2	SGN000532058	Klammer
4	1	SGS53219920226	Schlauch
5		-	Nicht verfügbar für diesen produkt

Illustration Schaltplan

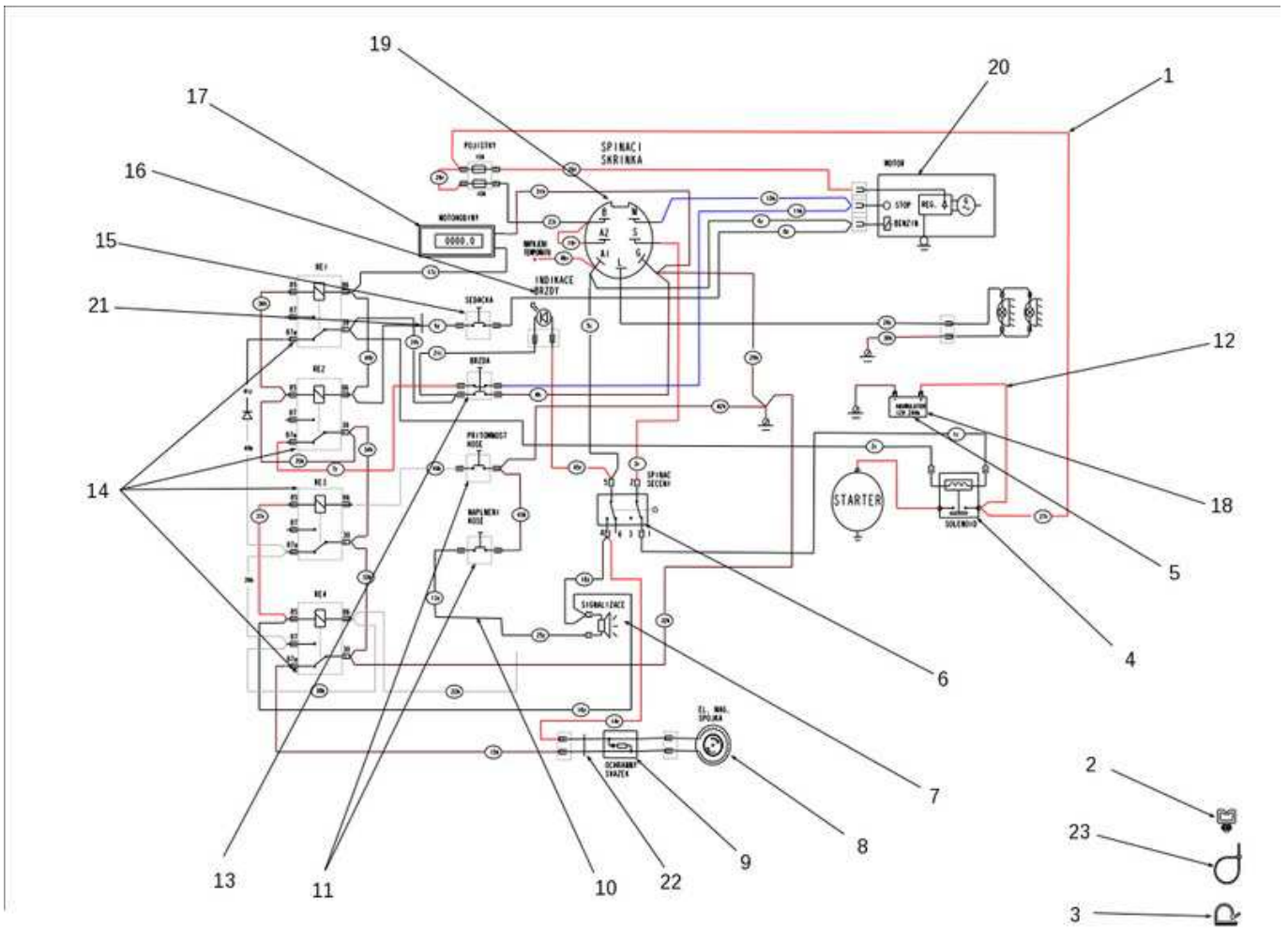

Illustration Schaltplan

Bild Nr.	St.- Zahl	Teile Nr.	Beschreibung
1	1	SGN341271151	Kabel
2	6	SGN321841071	Gabel
3	12	SGN532150211	Aufhängung
4	1	SGN000532033	Solenoid
5	1	SGN341271006	Leiter
6	1	SGN345329022	Schalter
7	1	SG443312021	Sperre
8	1	SGN000532010	Kupplung
9	1	SGN341271052	Diode
10	1	SGN341271134	Leiter
11	2	SGN345359004	Schalter korb 2008/09/10
12	1	SGN341271005	Leiter
13	1	SGN532150994	Schalter
14	4	SGN443811004	Relais
15	1	SGN345359005	Schalter
16	1	SGN443312022	Warnlicht
17	1	SGN443433003	Schalter
18	1	SGN341271021	Leiter
19	1	SGN443861007	Schaltschrank
20	1	SGN341271004	Kabel
21	2	SGN273121036	Buchse
22	1	SGN273121029	Buchse
23	8	SGN532150207	Band

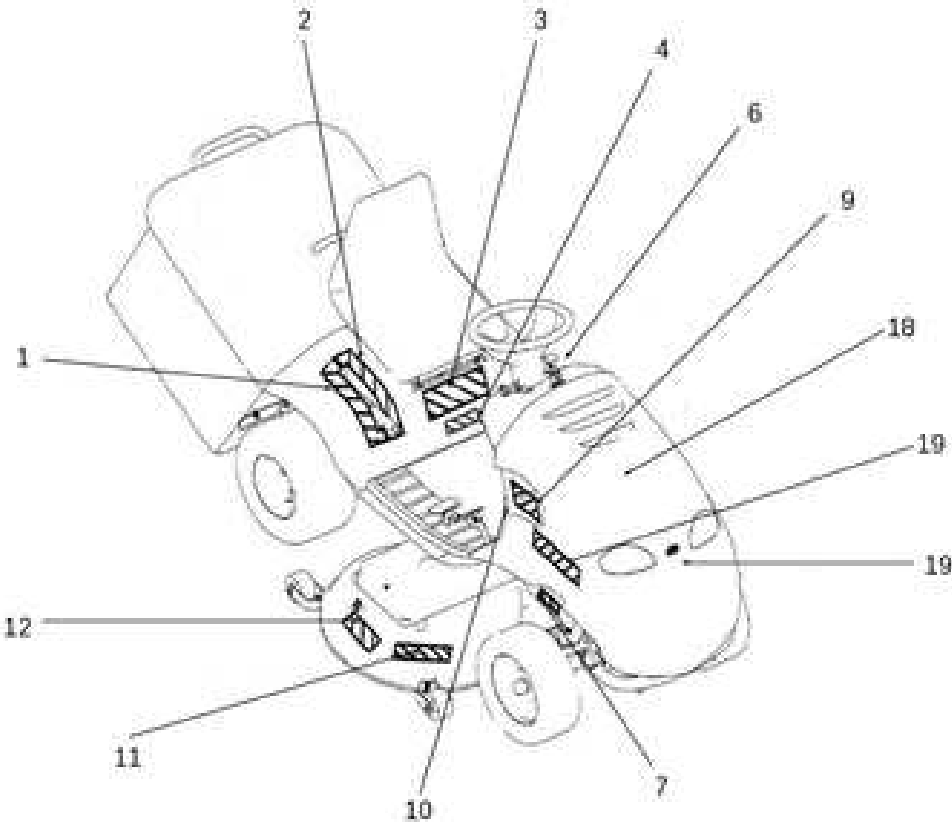
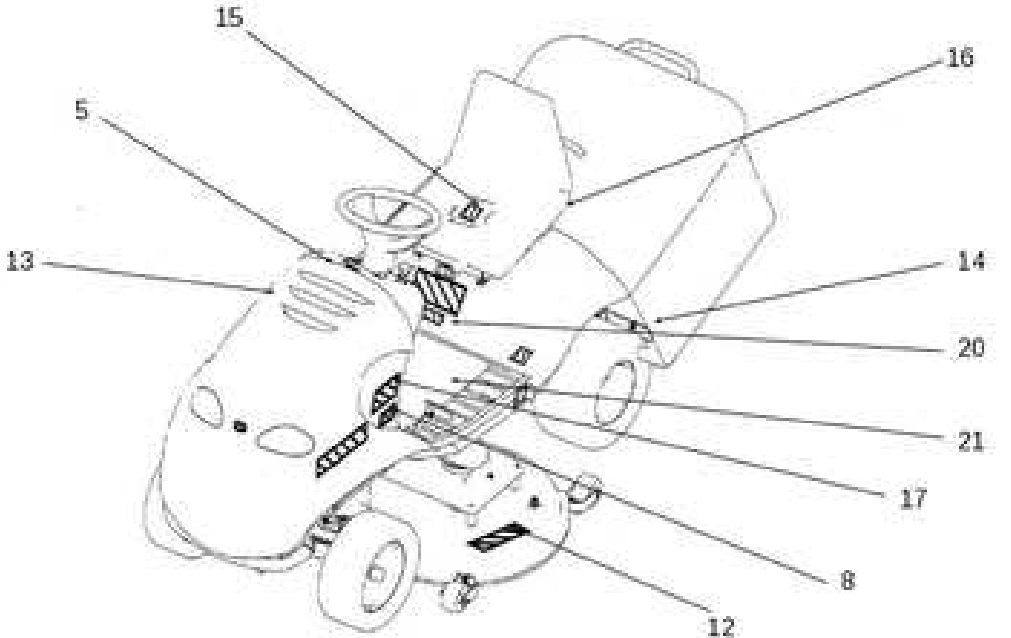

Illustration Etiketten

Bild Nr.	St.- Zahl	Teile Nr.	Beschreibung
1	1	SGN283292615	Etikette
2	1	SGN283292614	Etikette
3	1	SGN283292228	Etikette
4	1	SGN283292159	Etikette
5	1	SGN283292705	Etikette
6	1	SGN283292706	Etikette
7	1	SGN283292223	Etikette
8	1	SGN283292697	Etikette
9	1	SGN283292327	Etikette
10	1	SGN283292230	Etikette
11	1	SGN283292437	Etikette
12	2	SGN283292121	Etikette
13	1	SGN735411025	Etikette
14	1	SGN283292129	Etikette
15	1	SGN283292637	Etikette
16	1	SGN283292126	Etikette
17	1	SGN283292696	Etikette
18	1	SGN735411026	Etikette
19	1	SGS53298601458	Schild
19	1	SGS53298601462	Schild
19	1	SGS53298601400	Schild
19	1	SGS53298601468	Schild - France
20	1	SGN283292701	Etikette
21	-	-	Nicht verfügbar für diesen produkt