

Ersatzteilliste EFCO
Liste des pièces de rechange EFCO

EF106J/18H 2012

Illustration Motor

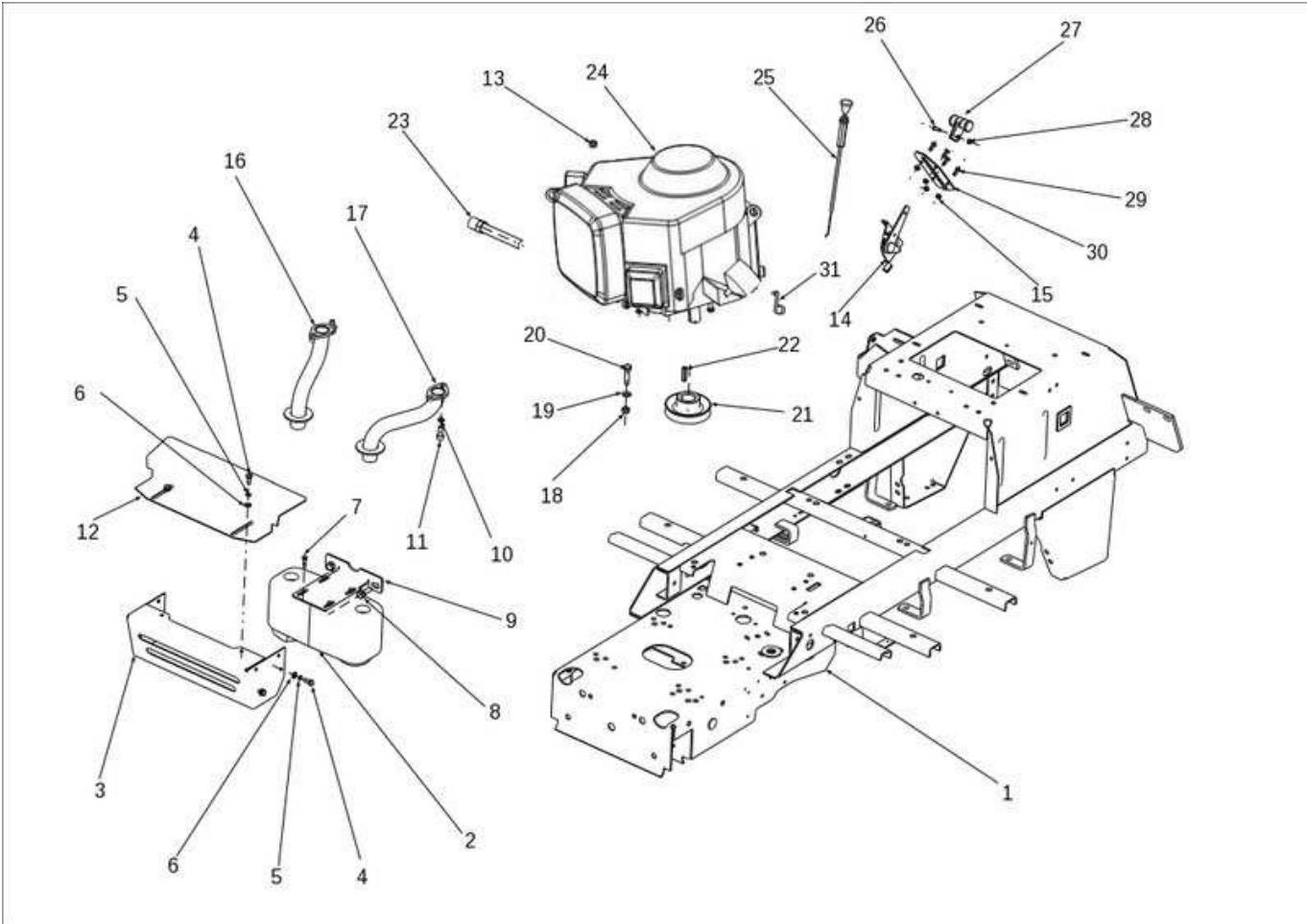

Illustration Motor

Bild Nr.	St.-Zahl	Teile Nr.	Beschreibung
1		SGS53291296277	Chassis
2		SGN443900129	Auspuff
3		SGS53208542729	Deckel
4		SGN309503508	Schraube
5		SGN311210502	Scheibe
6		SGN311214501	Scheibe
7		SGN309315016	Schraube
8		SGN309503005	Schraube
9		SGS53211340501	Halter
10		SGN311214502	Scheibe
11		SGN309503518	Schraube
12		SGS53208541574	Deckel
13		SGN311122501	Mutter
14		SGN000443006	Hebel
15		SGN311129515	Mutter
16		SGS53292744222	Rohr
17		SGS53292744223	Rohr
18		SGN311129501	Mutter
19		SGN311210503	Scheibe
20		SGN309503543	Schraube
21		SG532150439	Scheibe
22		SG532092312133	Schlüssel
23		SG532927262043	Verlaengerung
24		-	Nicht verfügbar für diesen produkt
25		SG443612011	Hebel
26		SGN309231535	Schraube
27		SGN443900138	Gashebel
28		SGN311129514	Mutter
29		SGN309251515	Schraube
30		SGS53208030287	Verstaerkung
31		SGN532980071	Haken

Illustration Vorderachse

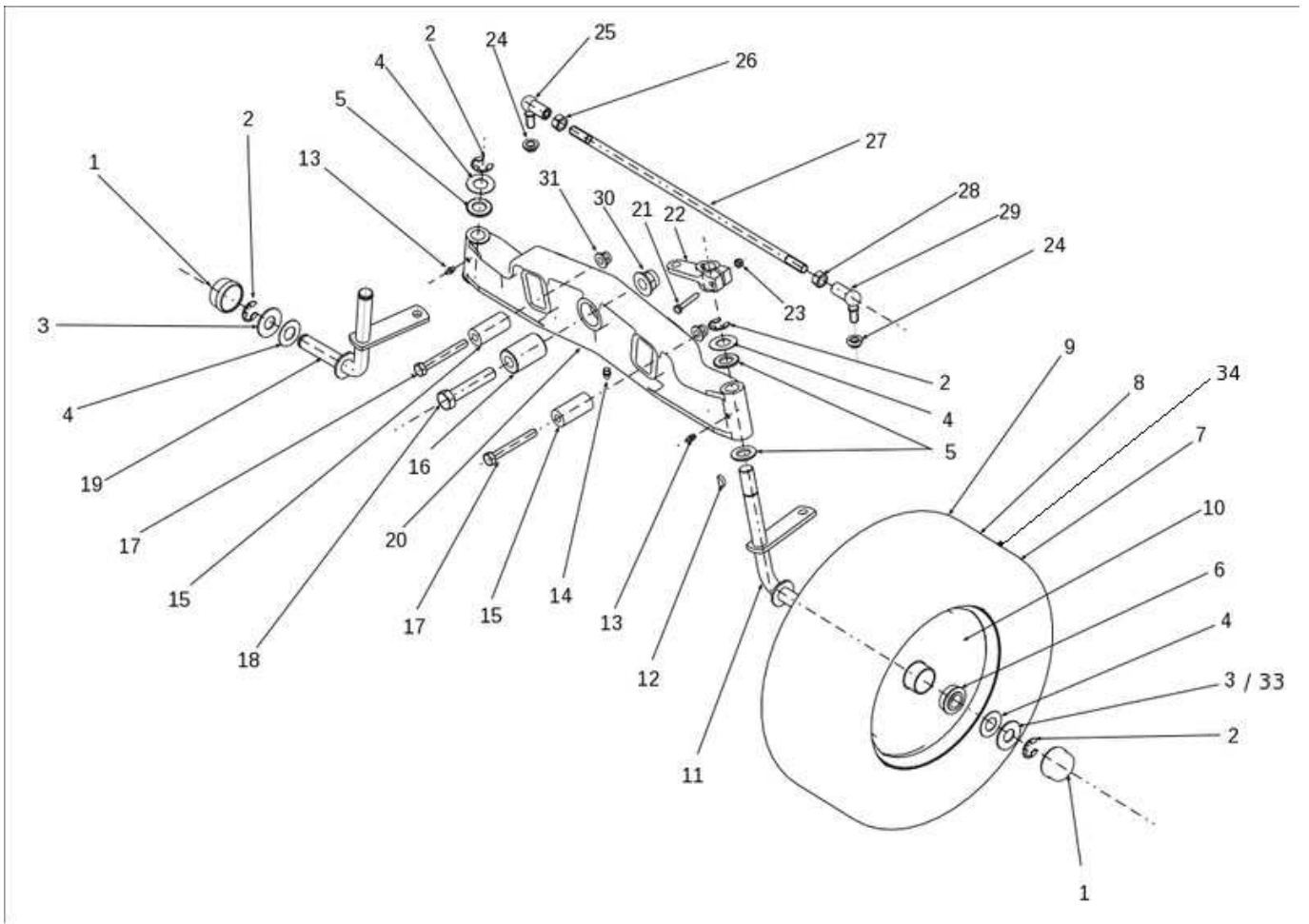

Illustration Vorderachse

Bild Nr.	St.-Zahl	Teile Nr.	Beschreibung
1		SGN532150915	Deckel
2		SGN311732008	Ring
3		SG532092208363	Scheibe
4		SGS53209220838	Scheibe
5		SGN311210514	Scheibe
6		SGN324196019	Lager
7		SGN532940133	Vorderrad
8		SGN274161023	Reifen vor
9		SGN000532135	Ventil
10		SG000532124	Schneidblatt
11		SG532916432143	Stift
12		SGN311728003	Schlüssel
13		SGN425111004	Fettnippel
14		SGN425111016	Fettnippel
15		SGN532150543	Distanzstück
16		SGN532150983	Stift
17		SGN309501527	Schraube
18		SGN309501524	Schraube
19		SG532916432153	Stift
20		SGS53201654206	Vorn achse
21		SGN309203524	Sechskantschraube
22		SGS53208050360	Hebel
23		SGN311129513	Sichermutter
24		SGN311129521	Mutter
25		SG947442073020	Dichtung
26		SGN311120504	Sechskantmutter
27		SG532980126	Stange
28		SGN311120539	Mutter
29		SGN442073019	Winkelstahl
30		SGN311129527	Mutter
31		SGN311129523	Mutter
34		SGN000532125	Reifenschlauch
33		SGS53209220815	Scheibe

Illustration Lenkgetriebe

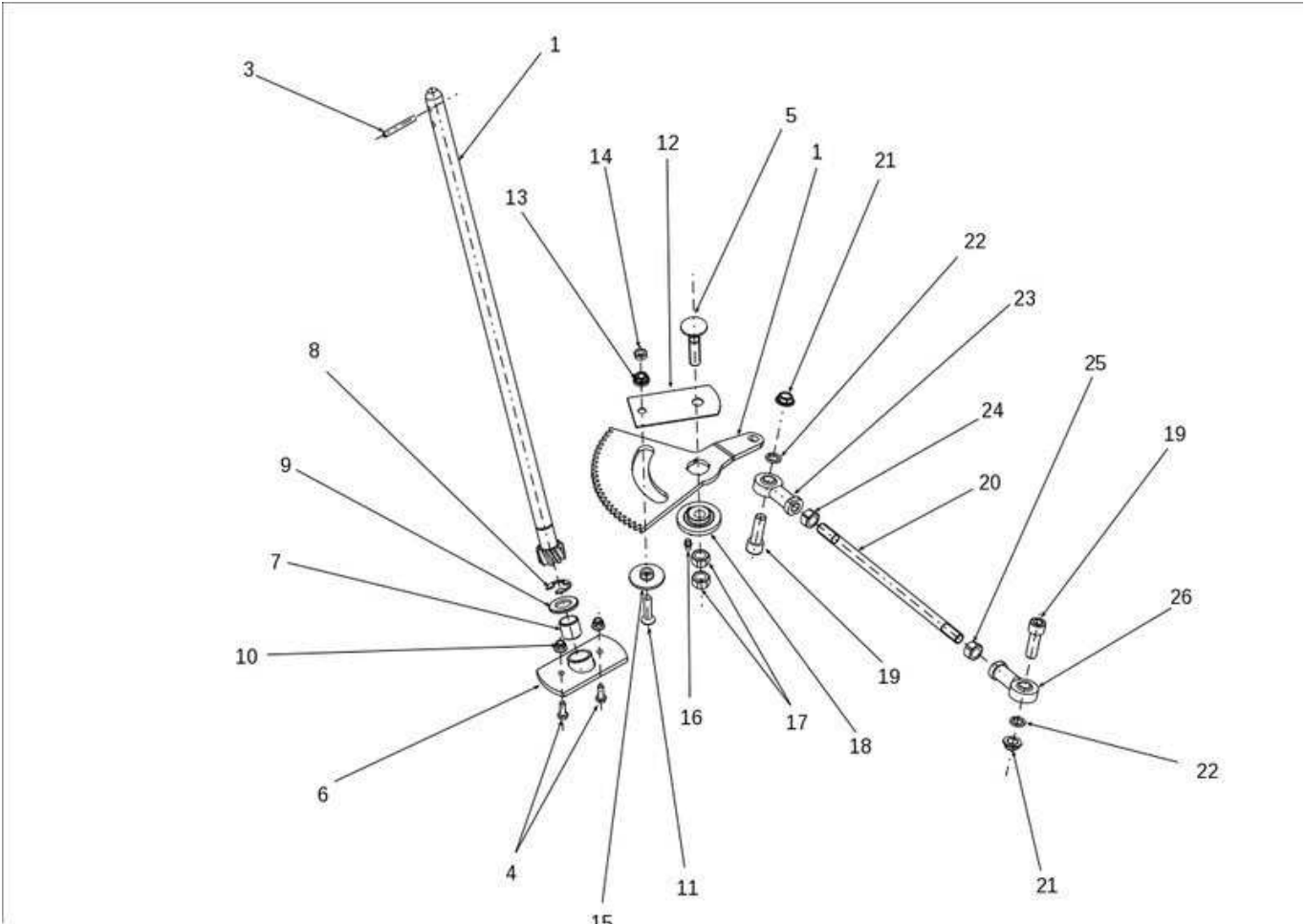

Illustration Lenkgetriebe

Bild Nr.	St.-Zahl	Teile Nr.	Beschreibung
1		68120021	Satz Ritzel und Zahnrad
3		SGN315238031	Stift
4		SGN309503548	Schraube
5		SGN309019522	Schraube
6		SG532938542043	Halter
7		SGN323721002	Lager
8		SGN311732008	Ring
9		SGN311210514	Scheibe
10		SGN311129525	Mutter
11		SGN309578534	Schraube
12		SGS53211332280	Platte
13		SGN311129520	Mutter
14		SGN311120520	Mutter
15		SGS53219520259	Distanzstück
16		SGN425111004	Fettnippel
17		SGN311150505	Mutter
18		SGS53208027203	Exzenter
19		SGN309543522	Schraube
20		SGN532980139	Welle
21		SGN311129521	Mutter
22		SGN311214504	Kugelscheibe
23		SGN442073028	Gehäuse
24		SGN311150505	Mutter
25		SGN311150516	Mutter
26		SGN442073029	Gehäuse

Illustration Mäheraushebung-schaltung

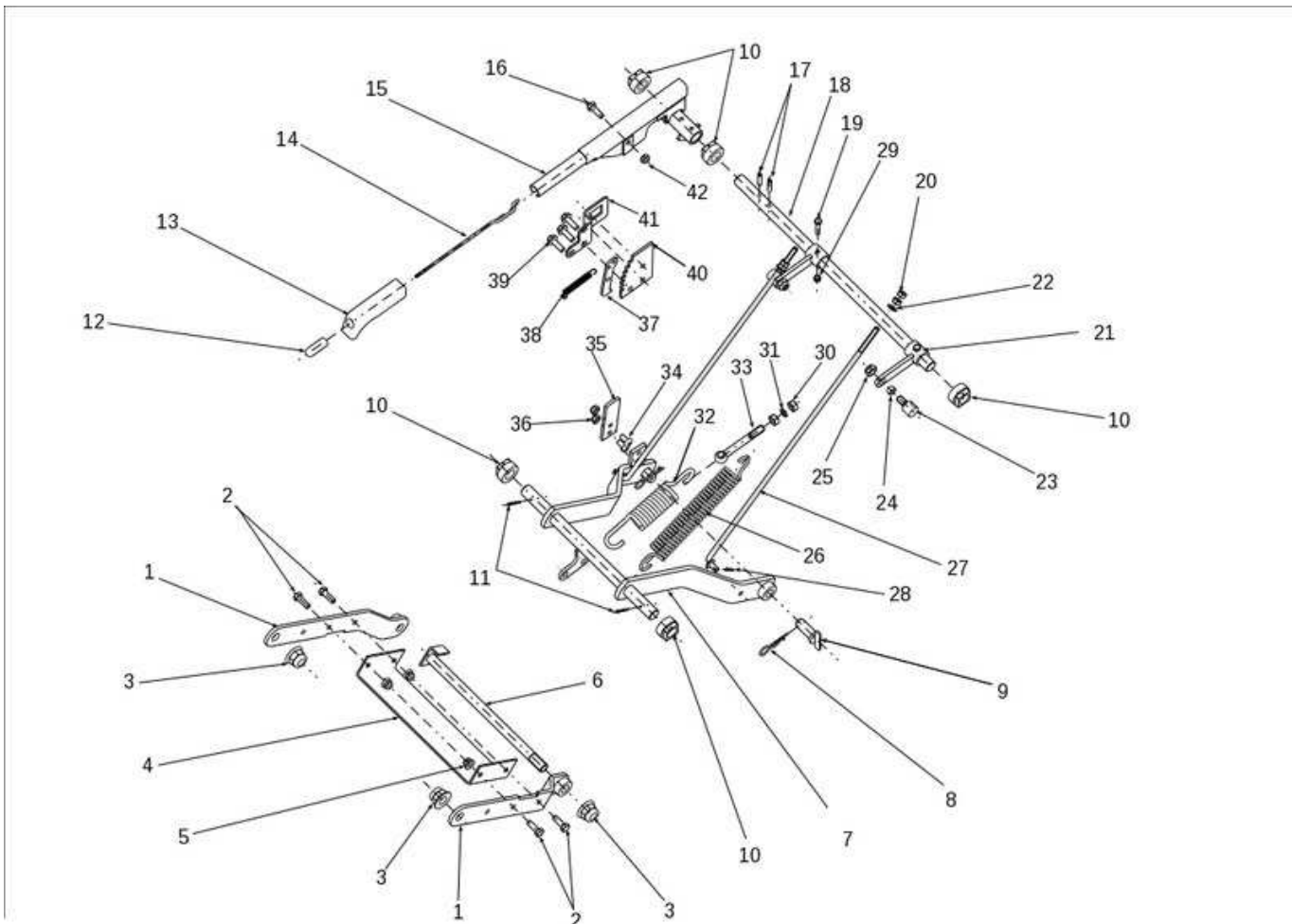

Illustration Mäheraushebung-schaltung

Bild Nr.	St.-Zahl	Teile Nr.	Beschreibung
1		SGS53298050822	Harm
2		SGN309503512	Schraube
3		SGN311129527	Mutter
4		SGS53208050367	Halter
5		SGN532150290	Mutter
6		SGS53293812253	Welle
7		SGS53298050820	Hubharm
8		SGN315238003	Splint
9		SG532993462343	Stift
10		SGN722643022	Buchse
11		SGN311338517	Stift
12		SG722643016	Toranschluss
13		SGN532150049	Handgriff
14		SGN315238034	Stange
15		SG532980522163	Hebel
16		SGN309503512	Schraube
17		SGN315238041	Stift
18		SGS53203810285	Welle
19		SGN309501568	Schraube
20		SGN311150503	Mutter
21		SGS53298046285	Komplett arm
22		SGN311210503	Scheibe
23		SGN532150507	Schraube
24		SGN532150729	Mutter
25		SGN311129502	Mutter
26		SGN315231193	Feder
27		SGN532980141	Spannstange
28		SGN311338516	Stift
29		SGN311129513	Sichermutter
30		SGN311150506	Mutter
31		SGN311214503	Scheibe
32		SGN315231165	Feder
33		SGN309510001	Schraube
34		SGN309578522	Schraube
35		SGS53211432722	Kupplungsblock
36		SGN311129501	Mutter
37		SGS53203732211	Platte
38		SGN315231158	Feder

Illustration Mäheraushebung-schaltung

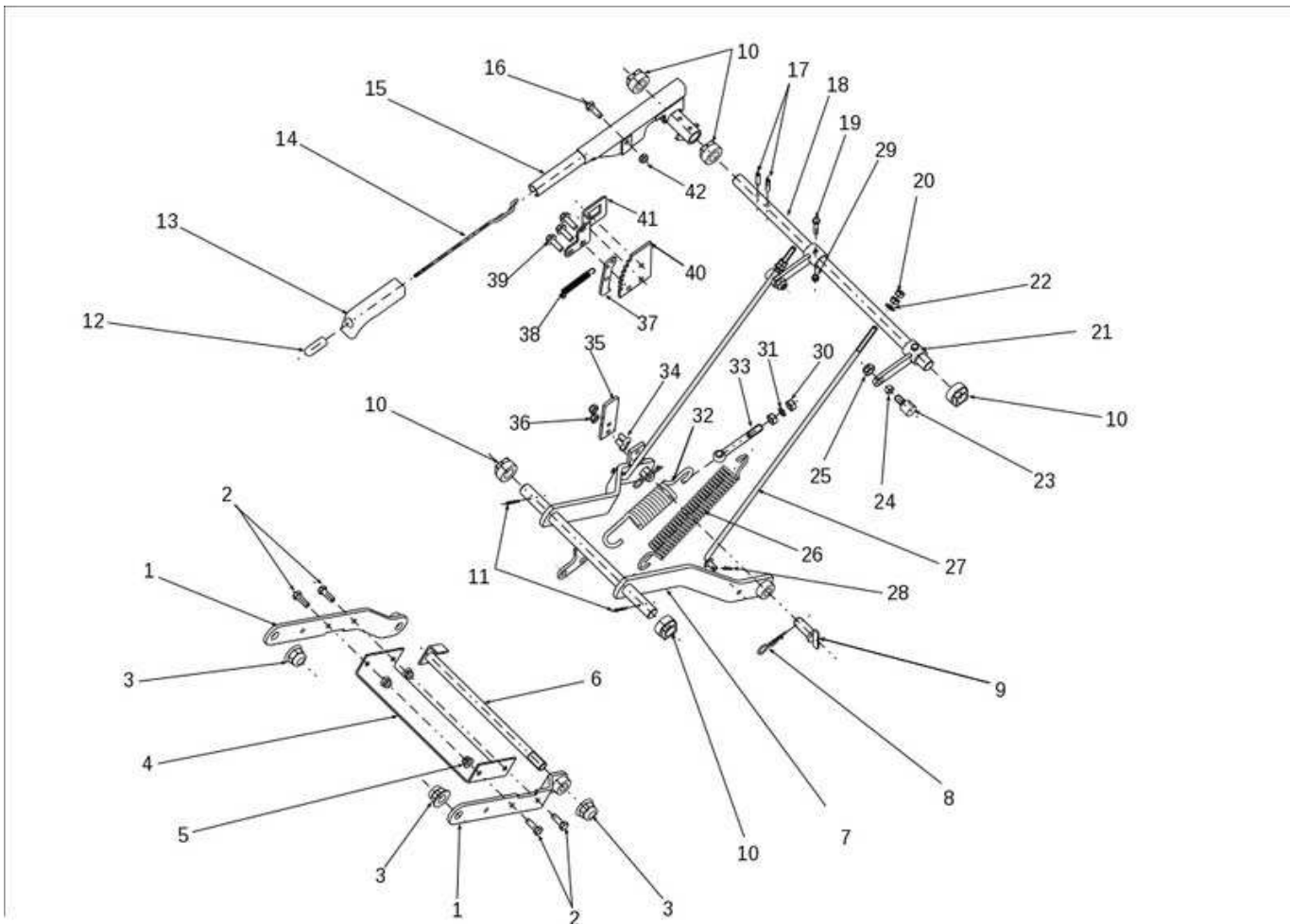

Illustration Mäheraushebung-schaltung

Bild Nr.	St.- Zahl	Teile Nr.	Beschreibung
39		SGN309503005	Schraube
40		SG532037322183	Zahnrad
41		SG532113414183	Halter
42		SGN311129501	Mutter

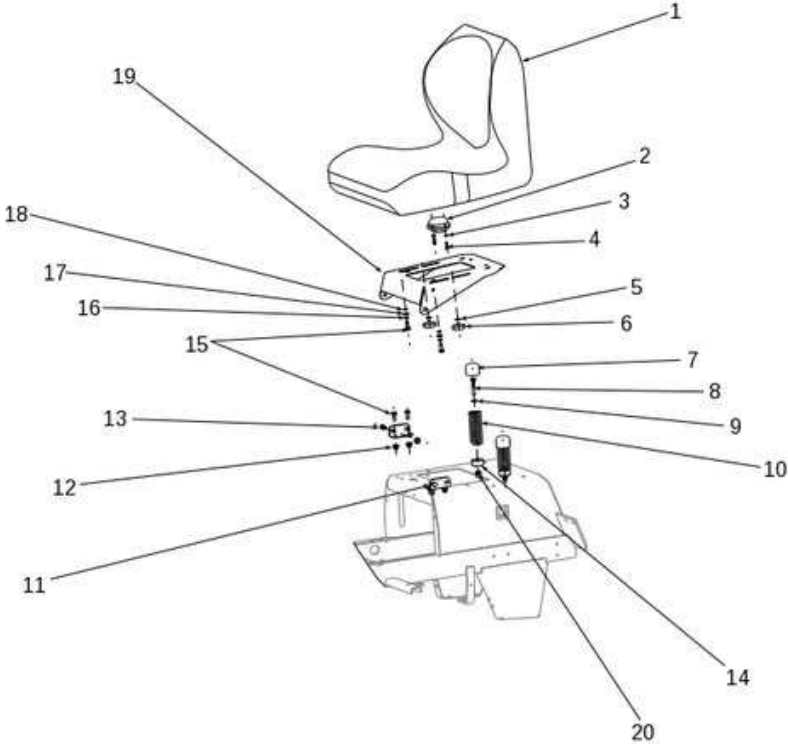

Illustration Kapotte (1/3)

Bild Nr.	St.- Zahl	Teile Nr.	Beschreibung
2		SGN345359005	Schalter
3		SGN311212515	Scheibe
4		SGN309315015	Schraube
5		SGN311213503	Scheibe
6		SGN532150213	Mutter
7		SG532150208	Stopfen
8		SGN309503559	Schraube
9		SGN311212517	Scheibe
10		SGN315231124	Feder
11		SGS53211340240	Halter
12		SGN532150290	Mutter
13		SGN309599012	Schraube
14		SGN532150992	Distanzstuck
15		SGN309503518	Schraube
16		SGN311210503	Scheibe
17		SGN311214502	Scheibe
18		SGN311219002	Scheibe
19		SGS53201847243	Sitz
20		SGN311129501	Mutter

Illustration Kapotte (2/3)

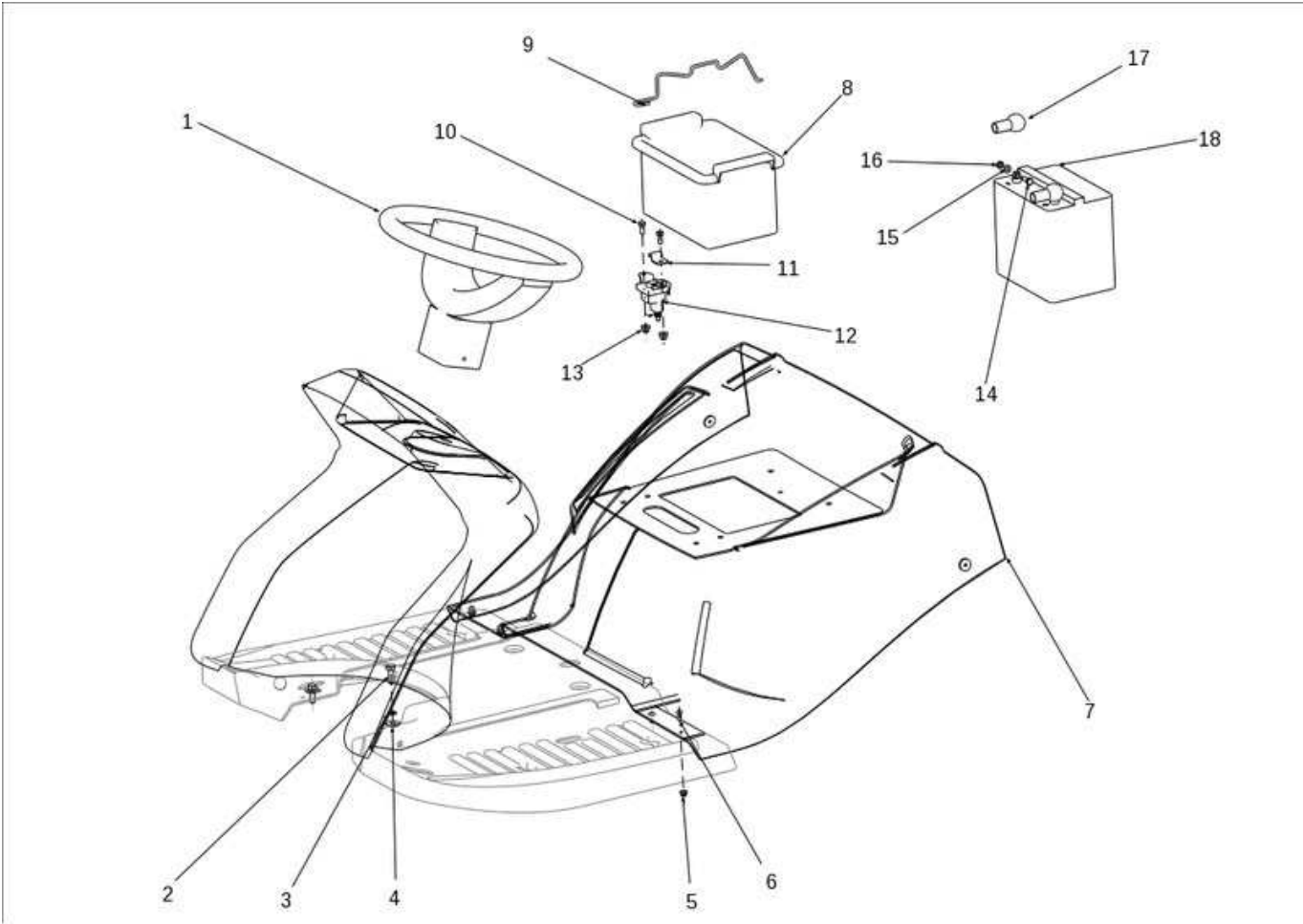

Illustration Kapotte (2/3)

Bild Nr.	St.-Zahl	Teile Nr.	Beschreibung
1		SG443821004R	Lenkrad
2		SGN309503512	Schraube
3		SGN311212517	Scheibe
4		SGN311214502	Scheibe
5		SGN311129524	Mutter
6		SGN309578532	Schraube
7		SGN532150859	Rahmen
8		SGN232130001	Batteriefach
9		SGN532880041	Halter
10		SGN309503508	Schraube
11		SGS53211341345	Ring
12		SGN000532033	Solenoid
13		SGN311129525	Mutter
14		SGN309503548	Schraube
15		SGN311210502	Scheibe
16		SGN311129513	Sichermutter
17		SGN273125006	Deckel
18		SGN346211006	Batterie

Illustration Schaltplan

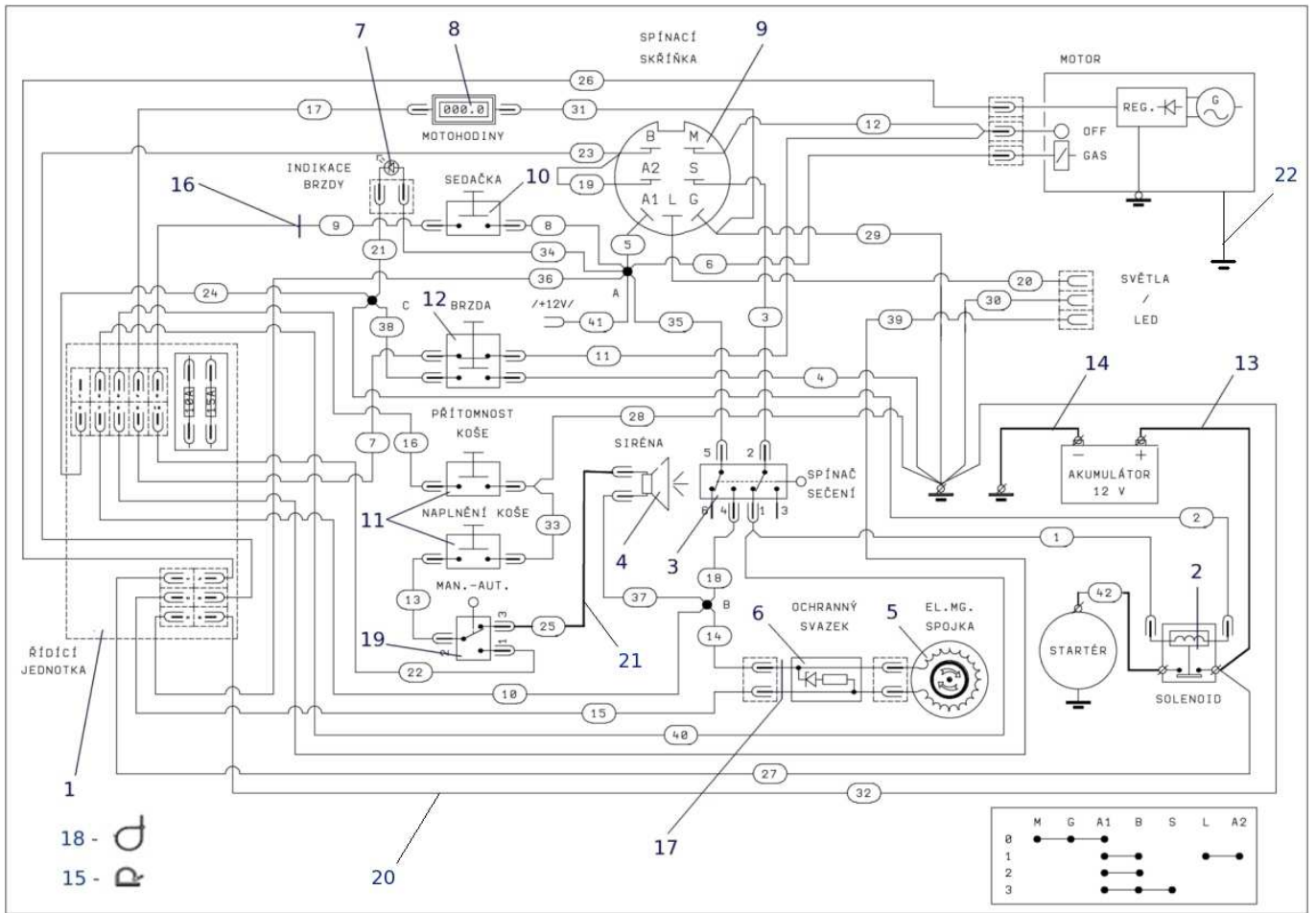

Illustration Schaltplan

Bild Nr.	St.-Zahl	Teile Nr.	Beschreibung
1		SGN341271162	Schaltplan
2		SGN000532033	Solenoid
3		SGN345329022	Schalter
4		SG443312021	Sperre
5		SGN000532010	Kupplung
6		SGN341271052	Diode
7		SGN443312022	Warnlicht
8		SGN443433003	Schalter
9		SGN443861007	Schaltschrank
10		SGN532150990	Sitzschalter
11		SGN345359004	Schalter korb 2008/09/10
12		SGN532150994	Schalter
13		SGN341271005	Leiter
14		SGN341271021	Leiter
15		SGN532150211	Aufhängung
16		SGN273121036	Buchse
17		SGN273121029	Buchse
18		SGN532150207	Band
19		SG947345329017	Schalter
20		SGN341271161	Kabel
21		SGN341271134	Leiter
22		SGN341271006	Leiter

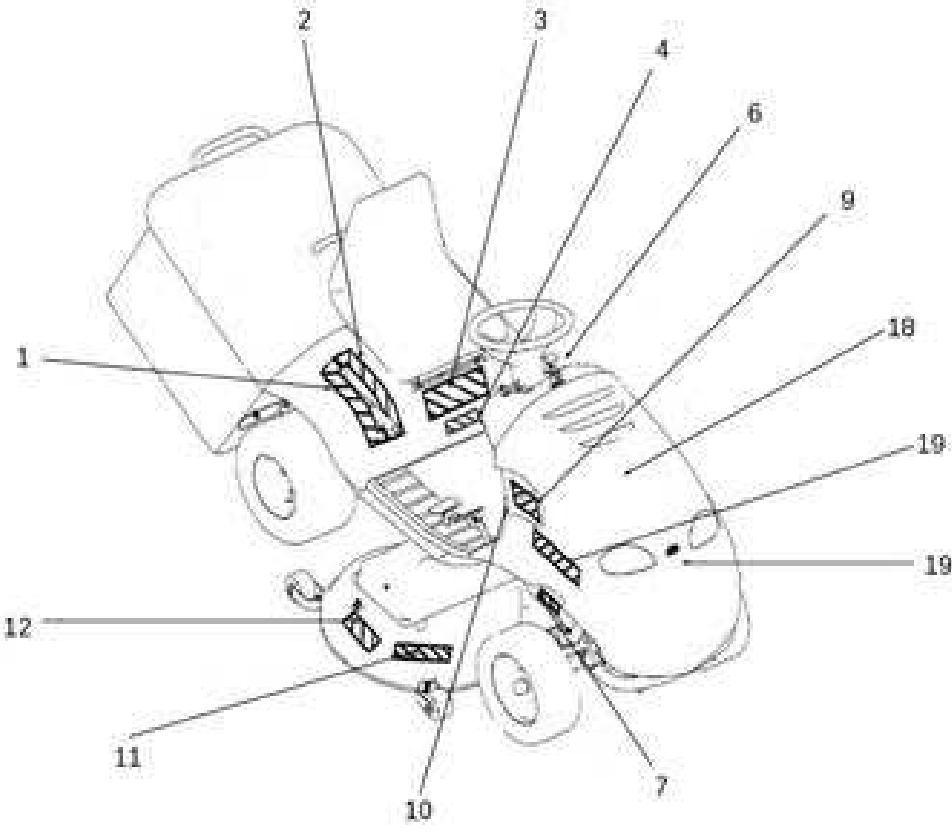
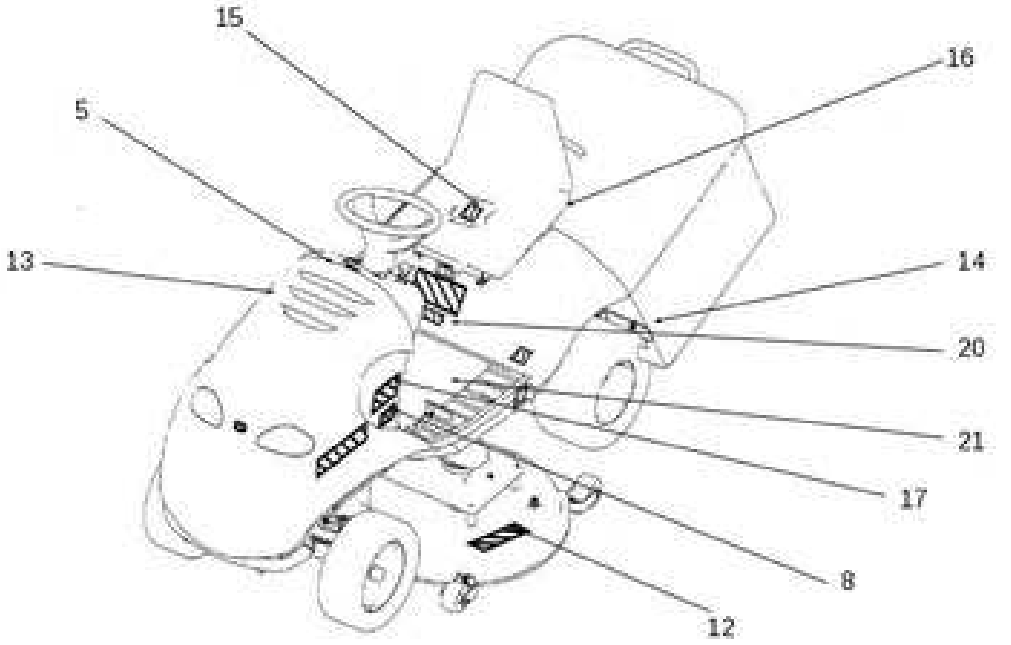

Illustration Etiketten

Bild Nr.	St.- Zahl	Teile Nr.	Beschreibung
1		SGN283292615	Etikette
2		SGN283292614	Etikette
3		SGN283292228	Etikette
4		SGN283292159	Etikette
5		SGN283292705	Etikette
6		SGN283292706	Etikette
7		SGN283292223	Etikette
8		SGN283292697	Etikette
9		SGN283292327	Etikette
10		SGN283292230	Etikette
11		SGN283292437	Etikette
12		SGN283292121	Etikette
13		SGN735411025	Etikette
14		SGN283292129	Etikette
15		SGN283292637	Etikette
16		SGN283292126	Etikette
17		SGN283292696	Etikette
18		SGN735411026	Etikette
19		SGS53298601458	Schild
19		SGS53298601462	Schild
19		SGS53298601400	Schild
20		SGN283292701	Etikette
21		-	Nicht verfügbar für diesen produkt

Illustration Stirwand

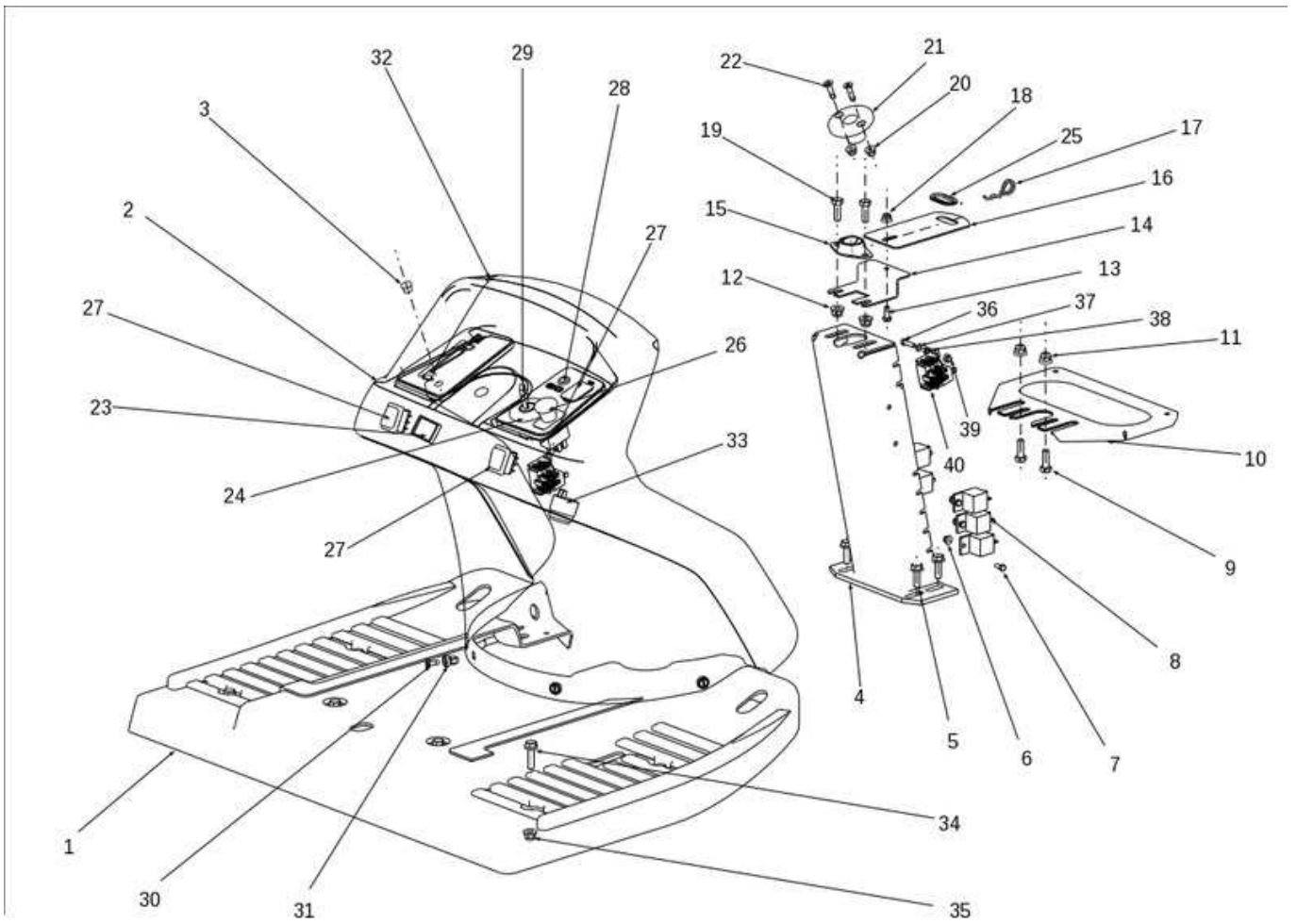

Illustration Stirnwand

Bild Nr.	St.-Zahl	Teile Nr.	Beschreibung
1		SGN532150950	Boden
2		SGN532150986	Panel
3		SGN321841082	Stopfen
4		SGS53291642205	Spurstange
5		SGN309503005	Schraube
6		SGN311129524	Mutter
7		SGN309203548	Schraube
8		SGN443811004	Relais
9		SGN309503512	Schraube
10		SGS53298342202	Halter
11		SGN532150290	Mutter
12		SGN532150290	Mutter
13		SGN309503508	Schraube
14		SGS53211341486	Halter
15		SGN000324001	Lager
16		SGS53211340469	Halter
17		SGN315238005	Stift
18		SGN311129525	Mutter
19		SGN309503512	Schraube
20		SGN311129525	Mutter
21		SGN321841069	Buchse
22		SGN309578503	Schraube
23		SGN443433003	Schalter
24		SGN443861007	Schaltschrank
25		SGN273121027	Buchse
26		SGN345329022	Schalter
27		SGN321841085	Schluss
28		SGN443312022	Warnlicht
29		SGN443900137	Schlüssel
30		SGN532150904	Schraube
31		SGN532150903	Buchse
32		SGS53209634216	Saum
33		SG443312021	Sperre
34		SGN309578012	Schraube
35		SGN532150290	Mutter
36		SGN309203567	Schraube
37		SGN311210501	Scheibe
38		SGN311150515	Mutter
39		SGN311129524	Mutter
40		SGN341271151	Kabel

Illustration Grasfangkorb

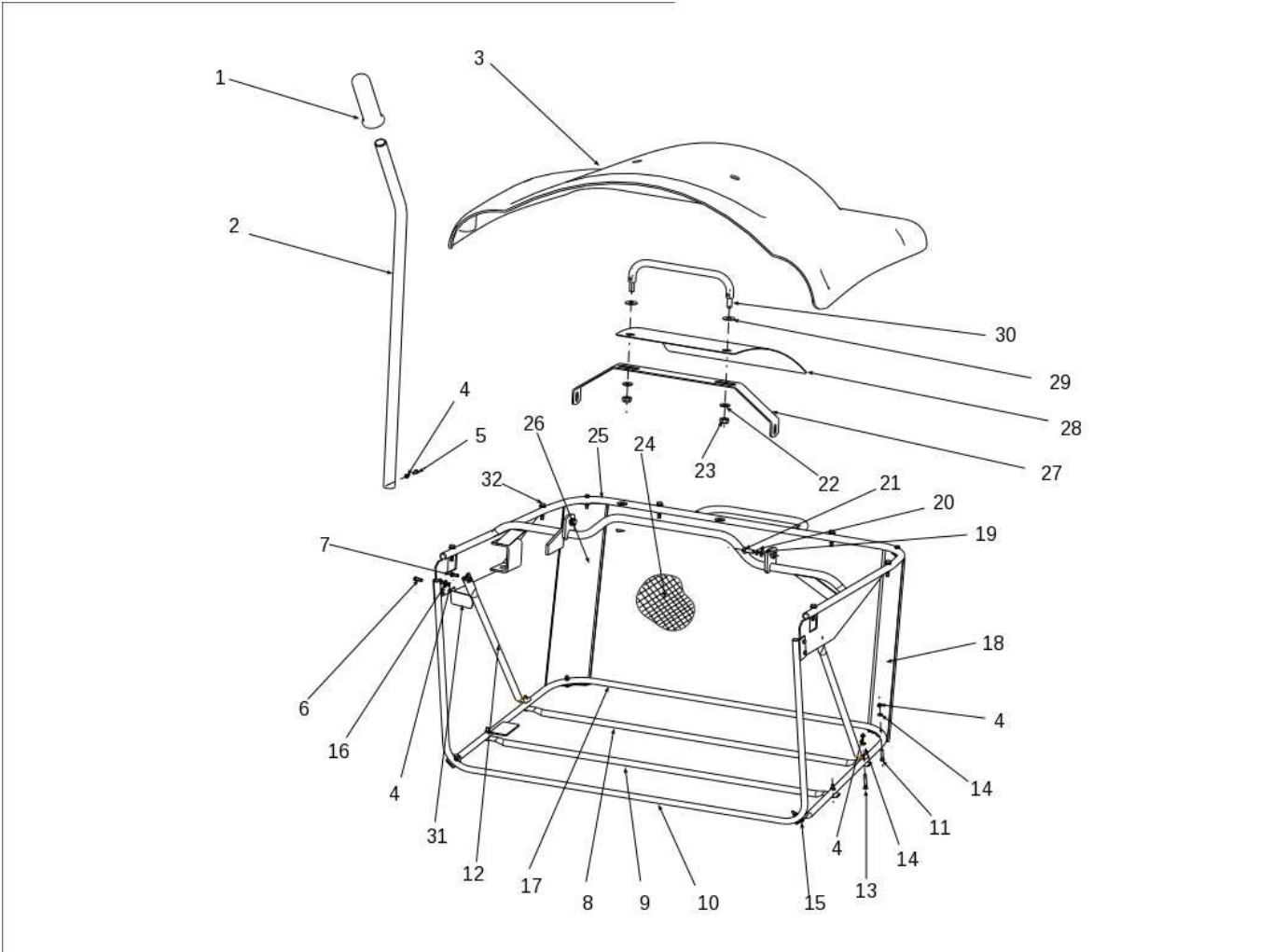

Illustration Grasfangkorb

Bild Nr.	St.-Zahl	Teile Nr.	Beschreibung
1		SGN532150864	Deckel
2		SGN532150007	Handgriff
3		SGN532150701	Hebel
4		SGN311129515	Mutter
5		SGN309203548	Schraube
6		SGS53297447229	Oberer rahmen
7		SGN311210504	Scheibe
8		SGS53291346325	Handgriff
9		SGN311129502	Mutter
10		SGN311212521	Scheibe
11		SG532074262023	Rahmen
12		SGS53207426201	Rohr
13		SGN309203556	Schraube
14		SGN532150699	Verstaerkung
15		SGN309203539	Schraube
16		SGN311210501	Scheibe
17		SGN309019514	Schraube
18		SGN311212514	Scheibe
19		SGN532150694	Rohr
20		SGN309203555	Schraube
21		SGN532150696	Rohr
22		SGS53207442227	Verstaerkung
23		SGN309503518	Schraube
24		SGN311210503	Scheibe
25		SGN311214502	Scheibe
26		SGN311120502	Mutter
27		SGN532151040	Verstaerkung
28		SGN309315013	Schraube
29		SGN309203557	Schraube
30		SGS53209740223	Zuendkerze
31		SGN532150135	Ersatzsack

Illustration Auswurf-träger fangkorb

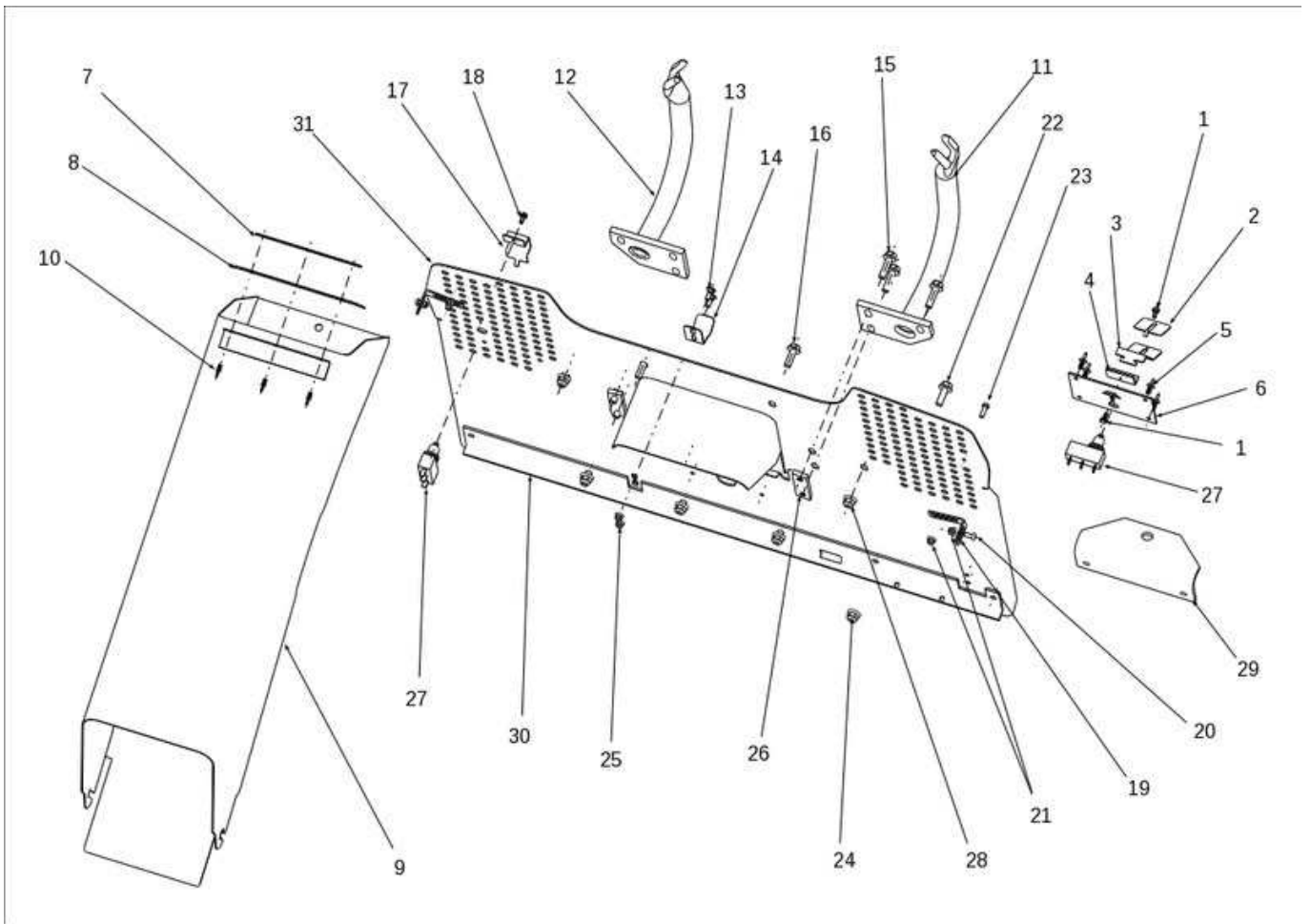

Illustration Auswurf-träger fangkorb

Bild Nr.	St.-Zahl	Teile Nr.	Beschreibung
1		SGN309315012	Schraube
2		SGS53201441474	Plattform
3		SGS53201441473	Plattform
4		SGS53211340468	Halter
5		SGN532150984	Niete
6		SGS53211430788	Plattform
7		SGS53211530857	Scheibe
8		SGN273192015	Deckel
9		SGS53297447268	Tunnel
10		SGN532151003	Niete
11		SGS53297443216	Halter
12		SGS53297443217	Halter
13		SGN309019514	Schraube
14		SGS53209746499	Feder
15		SGN309578012	Schraube
16		SGN309503005	Schraube
17		SGN273151001	Deckung
18		SGN309315011	Schraube
19		SGS53201440890	Halter
20		SGN309578532	Schraube
21		SGN311129524	Mutter
22		SGN309578011	Schraube
23		SGN309203539	Schraube
24		SGN532150290	Mutter
25		SGN311129524	Mutter
26		SGS53221530201	Verstaerkung
27		SGN345359004	Schalter korb 2008/09/10
28		SGN532150290	Mutter
29		SGN532150296	Aufhängung
30		SGS53211340323	Halter
31		SGS53297442222	Panel

Illustration Getriebe

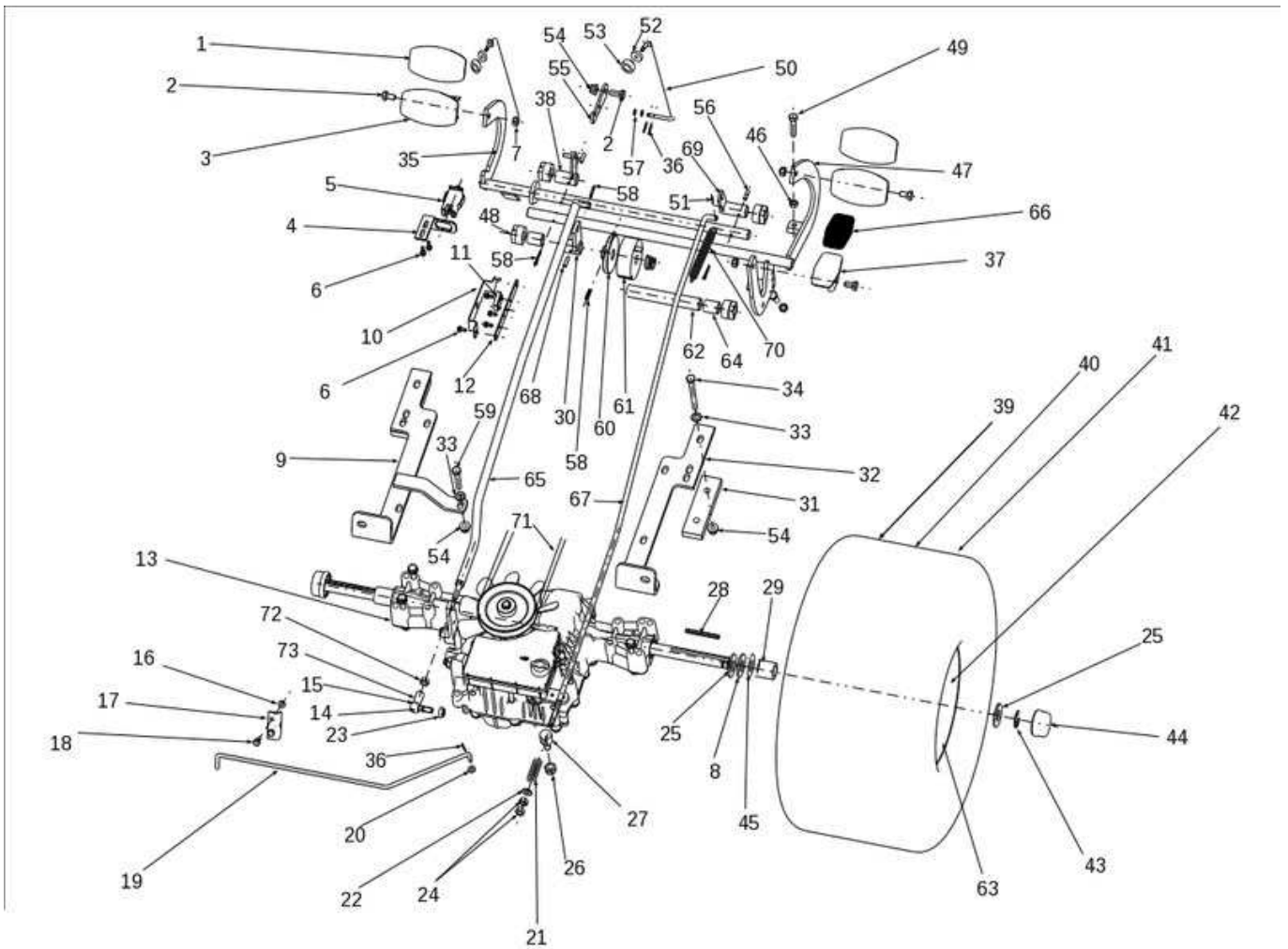

Illustration Getriebe

Bild Nr.	St.-Zahl	Teile Nr.	Beschreibung
1		SGN273151001	Deckung
2		SGN309503518	Schraube
3		SGS53298051257	Fusshebel
4		SGS53211340500	Halter
5		SGN532150994	Schalter
6		SGN309315012	Schraube
7		SGN311129501	Mutter
8		SGS53209220815	Scheibe
9		SGS53291336844	Halter
10		-	Nicht verfügbar für diesen produkt
11		-	Nicht verfügbar für diesen produkt
12		-	Nicht verfügbar für diesen produkt
13		SGN532991052	Antrieb K46
14		SGN442073018	Mutter
15		SGN442073017	Winkelstahl
16		SGN311129524	Mutter
17		SGS53211340391	Halter
18		SGN309203539	Schraube
19		SGN532150724	Hebel
20		SGN311210502	Scheibe
21		SGN315231240	Feder
22		SGN311212517	Scheibe
23		SGN311129520	Mutter
24		SGN311120520	Mutter
25		SG532092208363	Scheibe
26		SGN311129502	Mutter
27		SGN532150507	Schraube
28		SGS53209231216	Feder
29		SGN532150542	Distanzstück
30		SGS53298036482	Arm
31		SGS53209230394	Scheibe
32		SGS53211340386	Halter
33		SGN311210503	Scheibe
34		SGN309501571	Schraube
35		SGS53298044250	Bremsepedal
36		SGN311338513	Stift

Illustration Getriebe

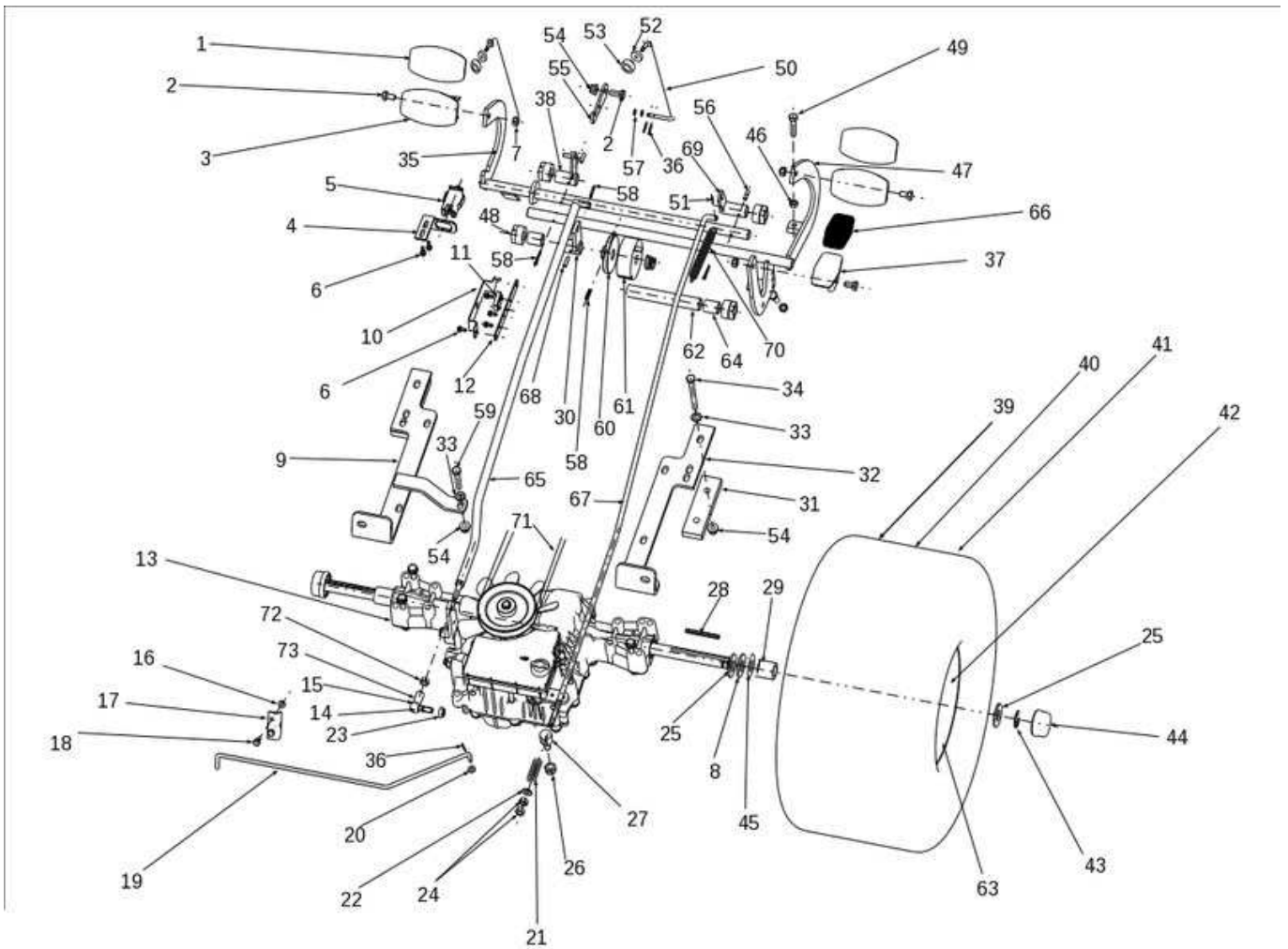

Illustration Getriebe

Bild Nr.	St.-Zahl	Teile Nr.	Beschreibung
37		SGS53298051258	Fusshebel
38		SGS53298036536	Verbindung
39		SGN532940135	Hinterrad
40		SGN274161024	Reifen
41		SGN000532133	Reifenschlauch
42		SGN000532134	Hinterrad
43		SGN311732023	Buchse
44		SGN532150915	Deckel
45		SGS53209220815	Scheibe
46		SGN311150503	Mutter
47		SGS53298044251	Hebel
48		SGN722643023	Buchse
49		SGN309503543	Schraube
50		SGN532980140	Bremse
51		SGN311338516	Stift
52		SGN273192027	Scheibe
53		SGN532150993	Scheibe
54		SGN532150290	Mutter
55		SGS53203732223	Haken
56		SGN315238050	Stift
57		SGN311210501	Scheibe
58		SGN311338517	Stift
59		SGN309503559	Schraube
60		-	Nicht verfügbar für diesen produkt
61		-	Nicht verfügbar für diesen produkt
62		-	Nicht verfügbar für diesen produkt
63		-	Nicht verfügbar für diesen produkt
64		SGN532150541	Buchse
65		SGN532150725	Spannstange
66		SGN273151011	Deckung
67		SGN532151121	Pleuel
68		SGN315238037	Stift
69		SG532980365183	Kupplungsblock
70		SGN315231161	Zuendkerze
71		SGN272731225	Riemen
72		SGN311150503	Mutter
73		SGN442073016	Buchse

Illustration Schneidwerkzeug (1/3)

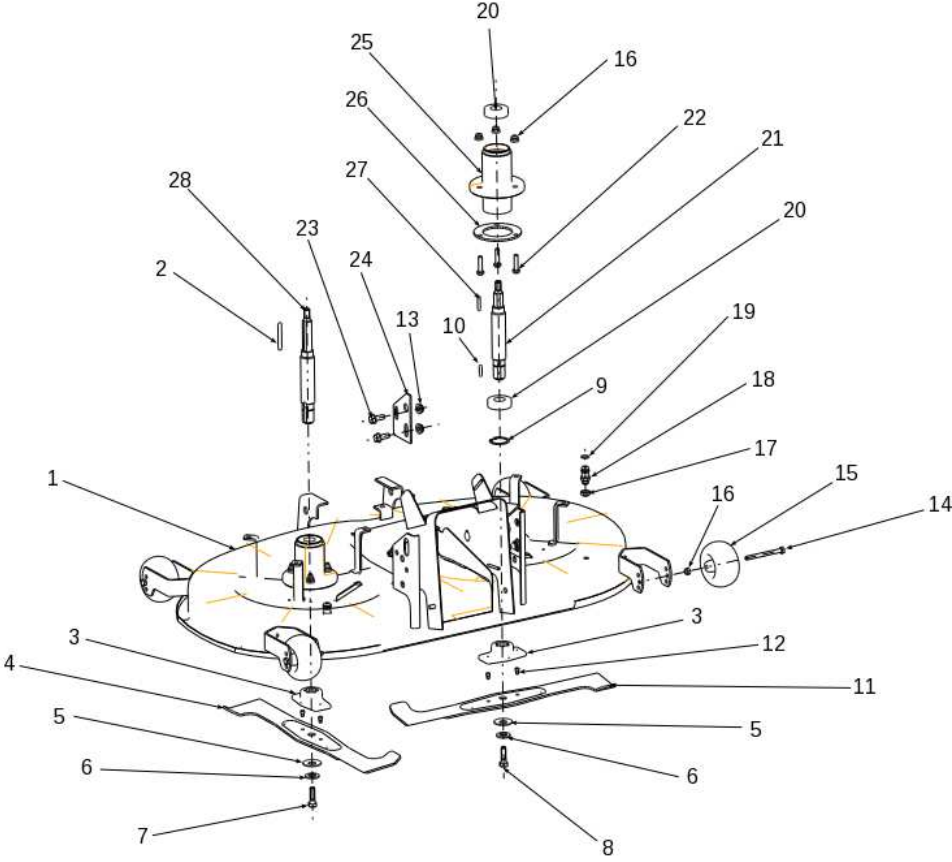

Illustration Schneidwerkzeug (1/3)

Bild Nr.	St.-Zahl	Teile Nr.	Beschreibung
1		SGS53295047226	Messerdeckel
2		SGN311726086	Feder
3		SG532098212403	Anpassungsglied
4		SG532050422533	Messer mulching
5		SGN311219503	Kugelscheibe
6		SGN532150519	Kugelscheibe
7		SGN309599017	Schraube
8		SGN309599008	Schraube
9		SGN311733014	Sicherungsring
10		SGN311726091	Feder
11		SG532050422543	Messer mulching
12		SGN532980077	Stiftschraube
13		SGN311129522	Mutter
14		SGN309501567	Schraube
15		SGN532940128	Rad
16		SGN532150290	Mutter
17		SGN311120511	Mutter
18		SGN532150533	Schnellanschluss
19		SGN273111057	Ring
20		SGN324162099	Lager
21		SG532038128023	Welle
22		SGN309503543	Schraube
23		SGN309578529	Schraube
24		SGS53211330891	Buchse
25		SGS53203852383	Deckel
26		SGS53209820337	Dichtung
27		SGN311726091	Feder
28		SG532038128033	Welle

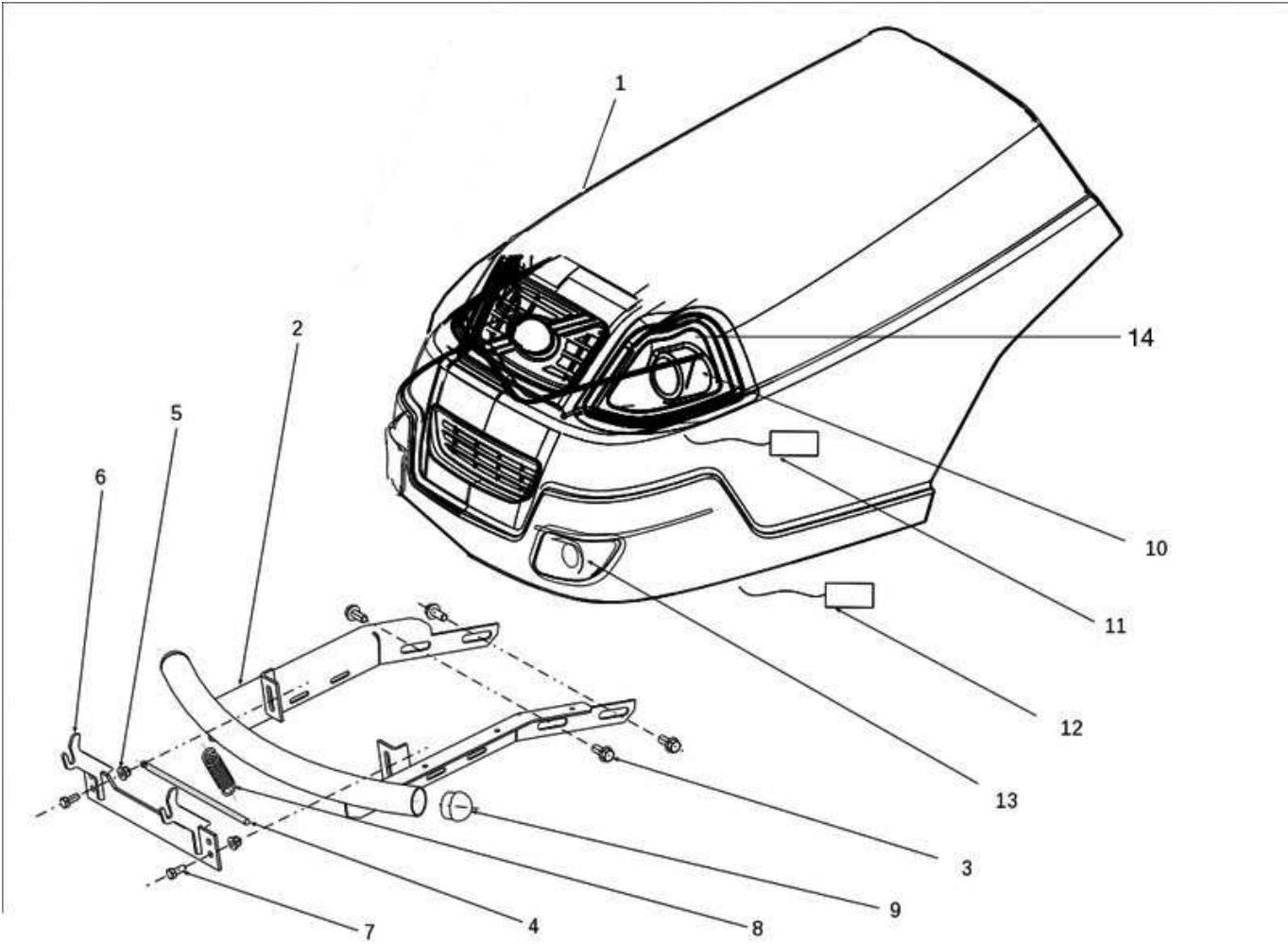

Illustration Kapotte (3/3)

Bild Nr.	St.- Zahl	Teile Nr.	Beschreibung
1	1	SGN532151006	Kofferraum
1	1	SGN532151068	Kapotte
2	1	SGS53291845210	Stossstangen
3	4	SGN309578529	Schraube
4	1	SGS53201310214	Sicherungsstange
5	2	SGN532150290	Mutter
6	1	SGS53291340312	Halter
7	2	SGN309503512	Schraube
8	1	SGN315231203	Feder
9	2	SGN321841087	Verschluss
10	2	SGN347411002	Glühlampe
11	2	SGN443953007	Kabel (Lampenhalter)
12		-	Nicht verfügbar für diesen produkt
13		-	Nicht verfügbar für diesen produkt
14	1	SGN532151054	Blende (Deckung)

Illustration Riemenscheibe

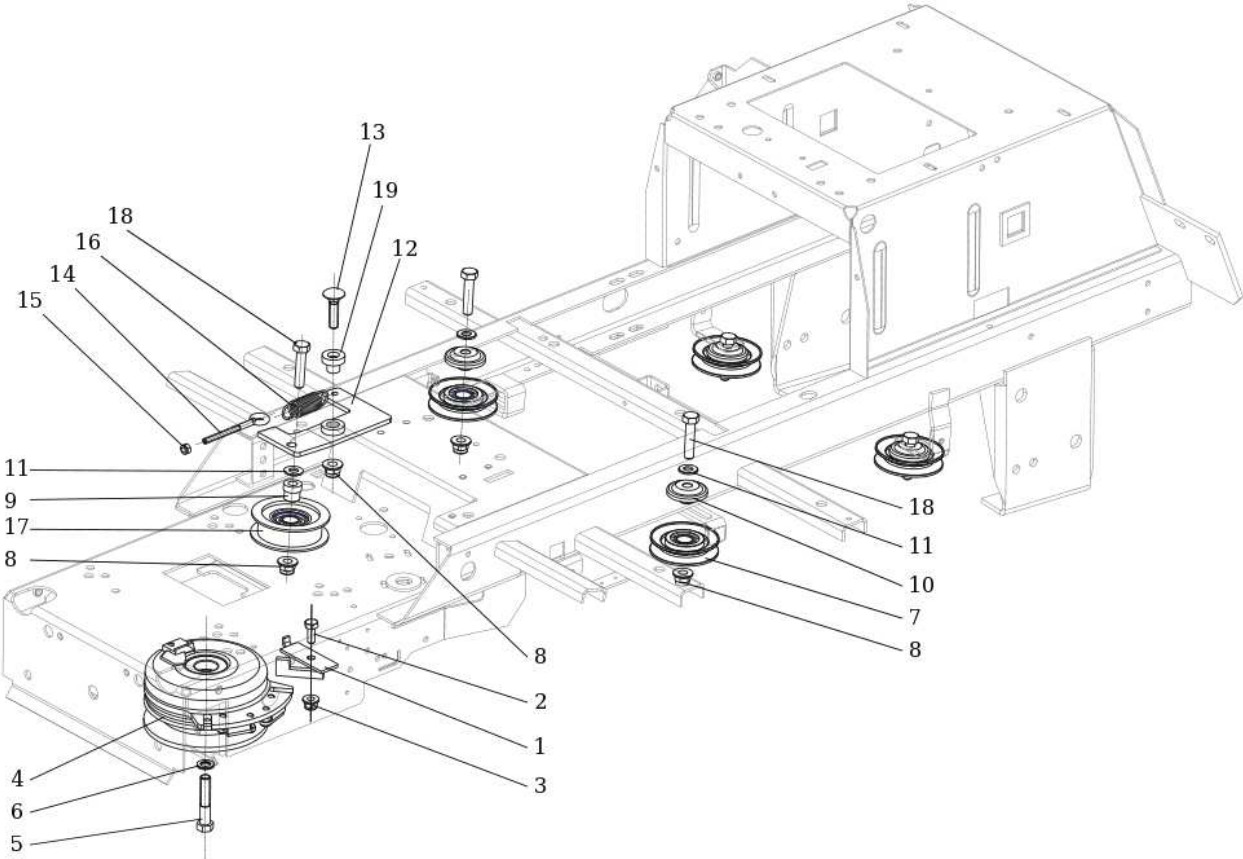

Illustration Riemenscheibe

Bild Nr.	St.-Zahl	Teile Nr.	Beschreibung
1		SGS53293636216	Führung
2		SGN309503518	Schraube
3		SGN532150290	Mutter
4		SGN000532010	Kupplung
5		SGN309579509	Schraube
6		SGN311219516	Scheibe
7		SGN532150824	Riemenscheibe
8		SGN311129523	Mutter
9		SG532094214183	Buchse
10		SGN532151119	Schultz
11		SGN311210504	Scheibe
12		SGS53291332276	Halter
13		SGN309019529	Schraube
14		SGN309578523	Schraube
15		SGN311129513	Sichermutter
16		SGN315231111	Zuendkerze
17		SGN532150733	Riemenscheibe
18		SGN309203544	Schraube
19		SGS53209421451	Buchse

Illustration Schneidwerkzeug (2/3)

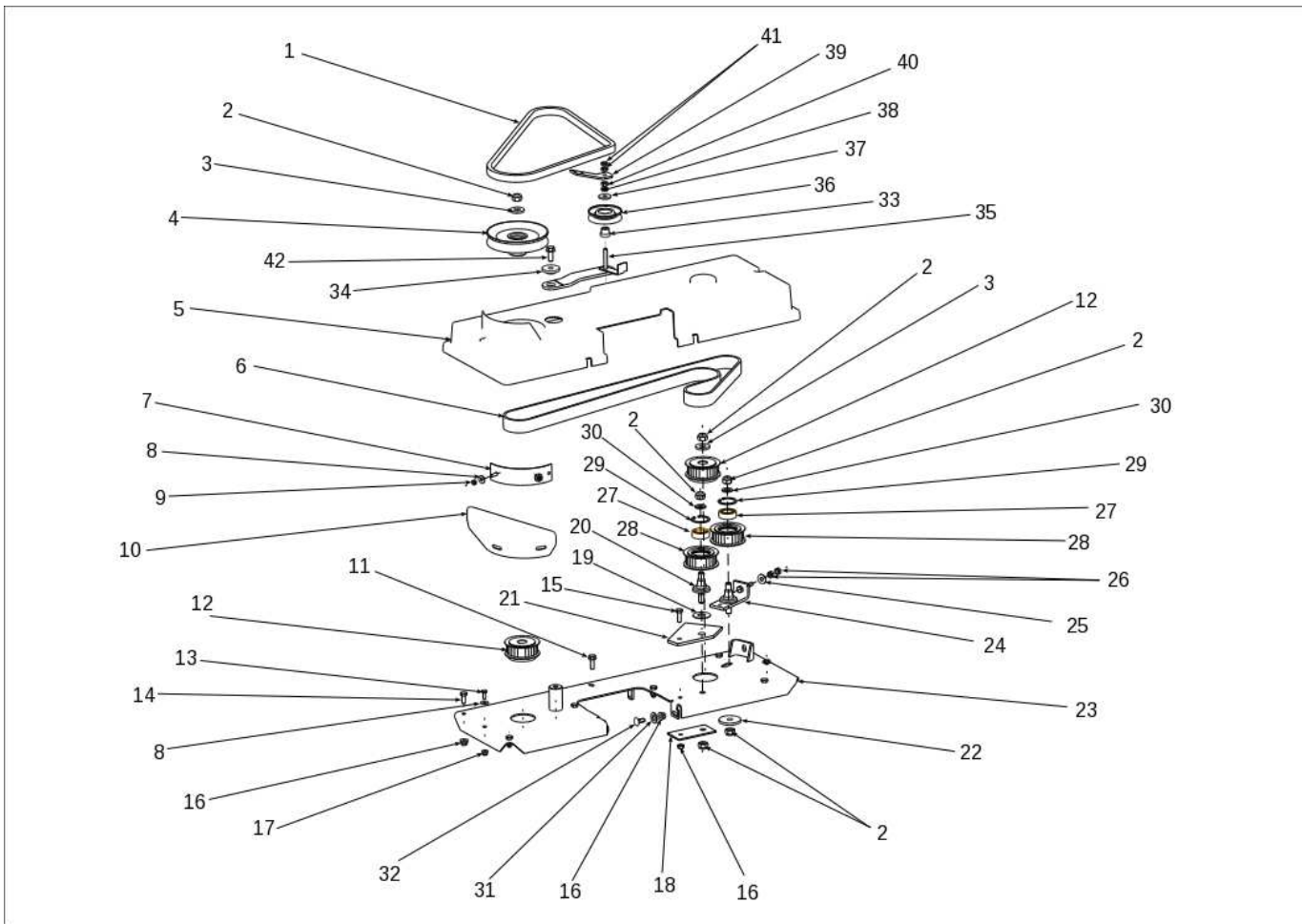

Illustration Schneidwerkzeug (2/3)

Bild Nr.	St.-Zahl	Teile Nr.	Beschreibung
1		SGN272731212	Riemen
2		SGN311129505	Mutter
3		SGS53209220727	Scheibe
4		SGN532150165	Riemenscheibe
5		SGN532150865	Deckel
6		SGN272211006	Riemen
7		SGS53298540273	Dichtung
8		SGN311212516	Scheibe
9		SGN311129513	Sichermutter
10		SGN532150559	Deckel
11		SGN309503005	Schraube
12		SGN532150860	Riemenscheibe
13		SGN309503508	Schraube
14		SGN309503518	Schraube
15		SGN309503512	Schraube
16		SGN532150290	Mutter
17		SGN311129525	Mutter
18		SGS53209230396	Halter
19		SGS53209220770	Scheibe
20		SGN532150806	Stiftschraube
21		SGS53209630397	Halter
22		SGS53209220753	Scheibe
23		SGS53298542346	Hauptplatte
24		SGS53291441231	Mutter
25		SGN311212517	Scheibe
26		SGN311150503	Mutter
27		SGN324162098	Lager
28		SGN532150836	Riemenscheibe
29		SGN311733079	Sicherungsring
30		SGN311210505	Scheibe
31		SGN311210505	Scheibe
32		SGN309019501	Schraube
33		SGS53209321263	Bolzen
34		SGN532150736	Scheibe
35		SGS53291342240	Halter komplett
36		SGN532150784	Kompensator

Illustration Schneidwerkzeug (2/3)

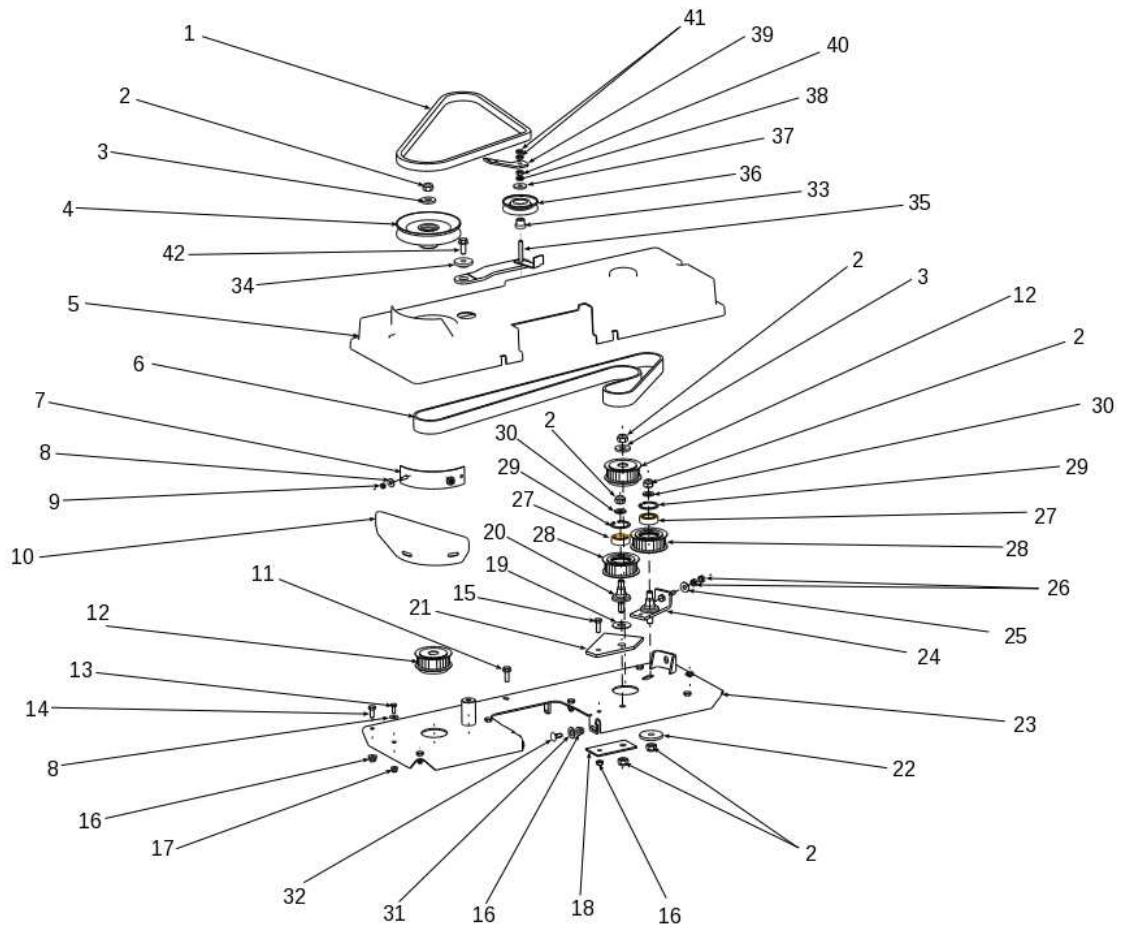

Illustration Schneidwerkzeug (2/3)

Bild Nr.	St.- Zahl	Teile Nr.	Beschreibung
37		SGN311212508	Scheibe
38		SGN311214502	Scheibe
39		SGS53211340235	Hebel
40		SGN311150503	Mutter
41		SGN311120520	Mutter
42		SGN309578529	Schraube

Illustration Tank

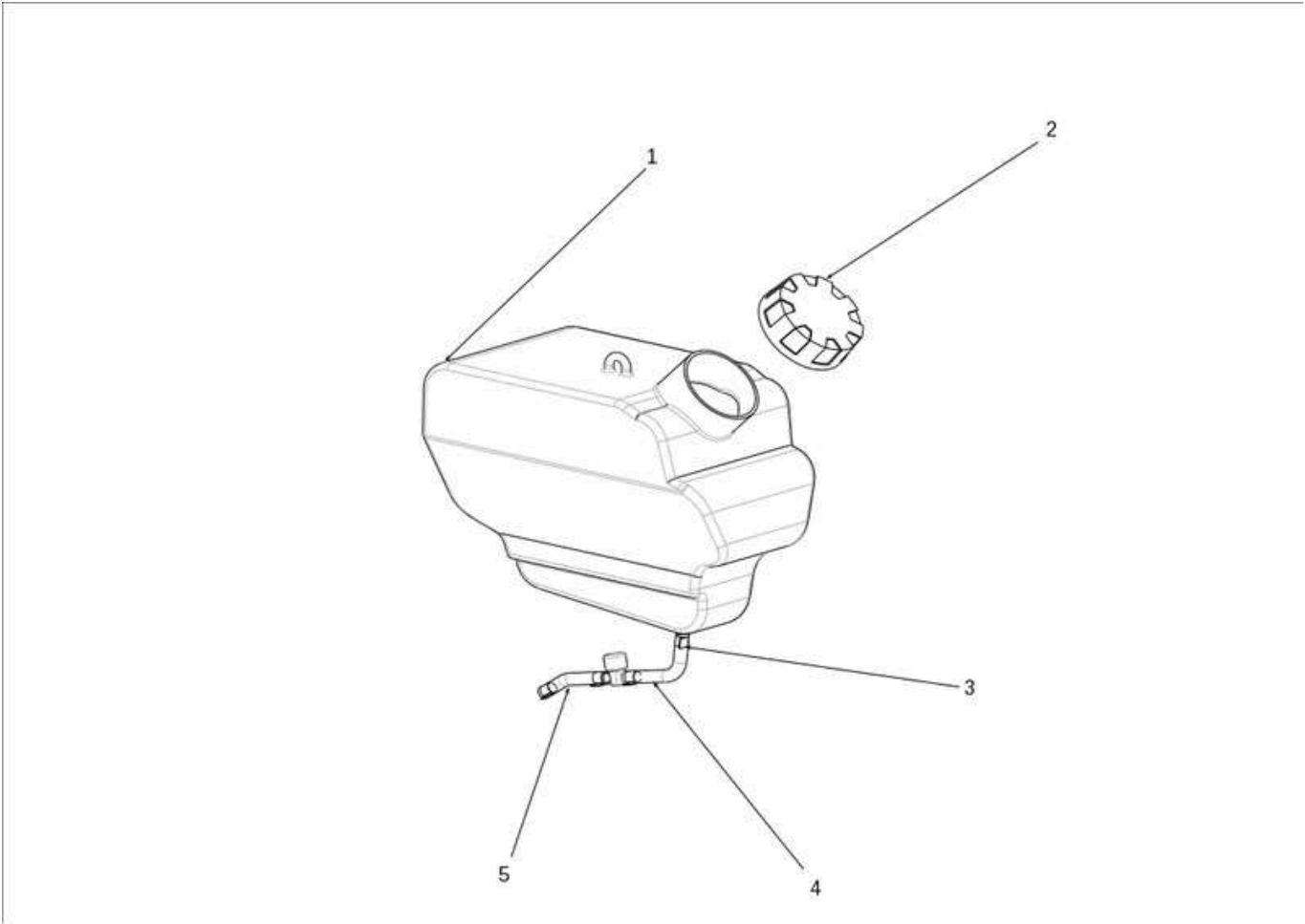

Illustration Tank

Bild Nr.	St.-Zahl	Teile Nr.	Beschreibung
1		SG532027662043	Tank
2		SGN321841017	Stopfen
3		SGN000532058	Klammer
4		SGS53219920226	Schlauch
5		-	Nicht verfügbar für diesen produkt

Illustration Schneidwerkzeug (3/3)

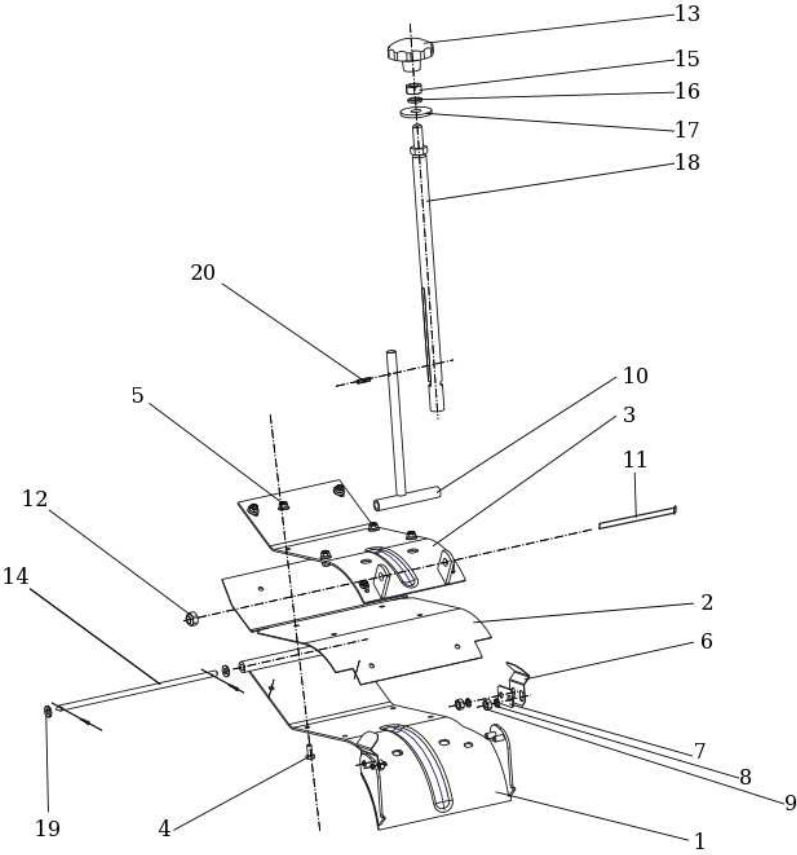

Illustration Schneidwerkzeug (3/3)

Bild Nr.	St.-Zahl	Teile Nr.	Beschreibung
1		SGS53291321207	Halter
2		SGS53298032218	Halter
3		SGN315238053	Stift
4		SGN311129515	Mutter
5		SGN311210501	Scheibe
6		SGS53291332293	Halter
7		SGN273192013	Deckel
8		SGN311129501	Mutter
9		SGN311210502	Scheibe
10		SGS53203810293	Stange
11		SGN311150506	Mutter
12		SGN311338513	Stift
13		SGN532150673	Bedienungsstern
14		SGN309203548	Schraube
15		SGS53298042214	Rolle
16		SGN311150504	Mutter
17		SGN311214501	Scheibe
18		SGN311210502	Scheibe
19		SGS53209742231	Feder
20		SGN309201522	Schraube