

Messrs. _____

L-0 model

Sebango code: AZ	MH	PT
Assy / B1:		
TB / C1:		
Pack / F1:		
Prod.Eng:		
Data:		

Drawing No.	G2-14320-0010(1/3)
DATE	Nov. 30th, 2005
Revision No.	
Revision Date	
Design model ID	714320B
Product. model ID	114320A

Engine Specification

For L100N6CA1T1AA

(Standard for General : Starting motor)

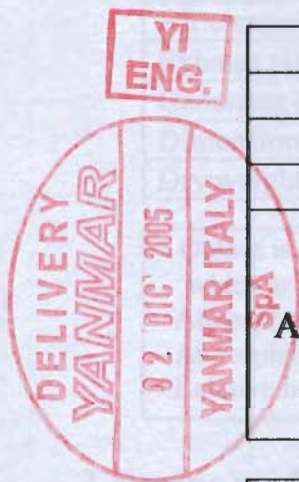

Contents		
Engine specifications		G2-14320-0010(2/3)
Engine performance		G2-14320-0010(2/3)
Details of specifications		G2-14320-0010(3/3)
Attached	Outline	B2-14320-0010
	Labels	G2-14220-2010
	Performance curve	
	Tools	C2-14110-0010
	Wiring	E2-14110-0010

Revision	(Nov.30th.2005)Registered by YITILU050092 After finishing Test in YJ,we will reissue with Spring Position & Performance Curve etc
----------	--



YI Engineering Dept.		
Manager	Checked	Drawn
J. Samo	J. Nishimura	J. Nishimura

Revision No.			
--------------	--	--	--

G2-14320-0010 (2/3)

1.Engine Specification

Model name			L100N6CA1T1AA
Type			4-stroke,vertical-cyl,air-cooled diesel
Combustion system			Direct injection
No. of cyl.-bore × stroke		mm	1- φ 86 × 75
Displacement		liter	0.435
Output	Continuous	kW/min ⁻¹	* 6.6 (9.0PS ,8.9HP) / 3600
	Maximum	kW/min ⁻¹	* 7.4 (10.0PS ,9.9HP) / 3600
PTO Shaft	PTO position		Crankshaft
	Direction of rotation		Counterclockwise viewed from PTO side
Injection Timing (FIC-air)		deg.	bTDC.13.0 ± 1.0
Fuel	Oil selection		Diesel fuel
	Tank capacity	liter	5.4
Lubricating	Oil selection		SAE 10W30,API grade CD or higher
	Oil capacity	liter	1.6 (effective,0.65)
Cooling system			Forced air cooling by flywheel fan
Starting system			Starter motor with re-coil starter
Governor			All speed type, mechanical
Balancer shaft			Single balancer shaft
Air cleaner			Dry type paper element filter
Exhaust silencer			Expansion silencer with cover
Generator (at 3600min ⁻¹)			Flywheel dynamo :12V-15A
Dimensions		mm	Indication in outline drawing
Dry weight		kg	Approx. 53.5

* Output is given for normal atmosphere conditions and Specs,
which are defined as follows:

- Atmospheric pressure: 100 kPa (750mmHg)
- Atmospheric temperature: 25°C
- Relative humidity: 30%

2.Engine performance

Speed at no load	Minimum	min ⁻¹	1200 or more	PTO Shaft (Without minimum idling speed adjust bolt. Adjustable figure by your end.)
	Maximum		3800 ± 30	
Governor regulation	Instantaneous speed difference	%	8 or less	
	Permanent speed change		5 or less	
	Recovery time	sec.	5 or less	
	Speed fluctuation	min ⁻¹	30 or less	
Permissible angle of inclination	Continuous	deg.	20	Operation of up to 3 minutes
	Intermittent		30	
Lowest start temperature	Re-coil starting	°C	0	Without starting aid agent
	Electric starting		-10	

Revision No.			
--------------	--	--	--

G2-14320-0010 (3/3)

3.Details of specifications (STD SPEC. L100N6CA1T1AA)

System	Part name	Code	STD Spec.	Specification	Remarks
Fuel System	Fuel tank	Bm-a	1	same as STD.	Color : Yanmar Black
	Tank stay (A)		114210-55210	same as STD.	
	Tank stay (B)		114310-55230	same as STD.	
	Nozzle, Fuel injection		714320-53100	same as STD.	
Lubricating System	Oil pressure switch	Cm-a	NA	same as STD.	
Cooling System	Flywheel	Dm-a	114699-21590	same as STD.	DE Type
	Fan case	Dm-b	114310-45100	same as STD.	Color : Gold Silver
	Eng cover	Dm-c	1	same as STD.	
Electric System	Electric Regulator & Harness, wire	-	114399-77550	same as STD.	For 12V-15A
	Dynamo Assy.	-	114399-78260	same as STD.	
	Air heater	Em-a	NA	same as STD.	
PTO&Flange	Crankshaft	Fm-a	1	same as STD.	E-D type
	Crank case cover	-	114310-01450	same as STD.	E-D type
Intake and Exhaust System	Air cleaner	Gm-a	1	same as STD.	
	Intake bend	Gm-b	NA	same as STD.	
	Silencer	Gm-c	1	same as STD.	
Starting System	Recoil starter Assy.	Hm-a	1	same as STD.	
	Starting motor	Hm-b	114362-77011	same as STD.	
Speed Control System	Control device Assy.	Im-a	1	same as STD.	General type
	Governor lever Assy.	-	114311-61500	same as STD.	2 lever type
	Fuel limiter Assy.	-	114211-66600	same as STD.	Torque limiter type
Decomp system	Bonnet	Lm-a	1	same as STD.	
Remarks	Fuel oil limiter : Locked by wire High idle adjust bolt : Locked by wire Lubricating Oil : Not provided Fuel Pump Model : N4A Recoil Angle: R5				
Loose parts	Key switch panel CMP		114351-77500	same as STD.	
	Connector		NA	same as STD.	
	Deflector		114699-13800	same as STD.	
	Tools		114299-92590	same as STD.	

3RD ANGLE PROJECTION

GEN. TOI.	DRAFT ANG.	PURCHASING SPECIFICATION		REQUEST FOR APPROVAL		DELIVERY DRAWING		INSPECTING STANDARD		QC-PROCESS		L-CAST		L-CHIP		ANG-CHIP		GT.CODE					
		OUTSIDE	INSIDE	NOMINAL DIM.	DIVISION	5 MAX	5 TO 10	10 TO 18	18 TO 30	30 TO 50	120 MAX	120 TO 250	250 TO 400	400 TO 800	800 TO 1600	1600 TO 3150	0.5 TO 6	6 TO 30	30 TO 120	120 TO 400	10 MAX	10 TO 50	50 TO 120

L-CAST		L-CHIP		ANG-CHIP	
120 MAX	±1.5	0.5 TO 6	±0.1	10 TO 50	±1 DEG.
120 TO 250	±2.0	6 TO 30	±0.2	50 TO 120	±20MIN.
250 TO 400	±3.0	30 TO 120	±0.3	120 TO 400	±10MIN.
400 TO 800	±4.0	120 TO 400	±0.5	400 MIN	±5MIN.
800 TO 1600	±5.0				
1600 TO 3150	±6.0				

FIGURE DIMENSION	GT.CODE	○ AND ◓: RADIAL
------------------	---------	-----------------

CAREER

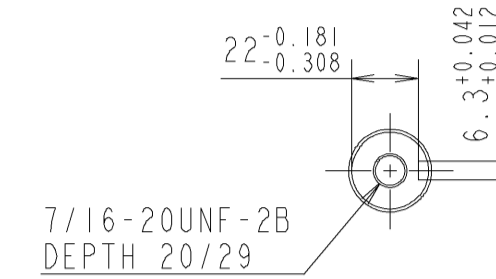
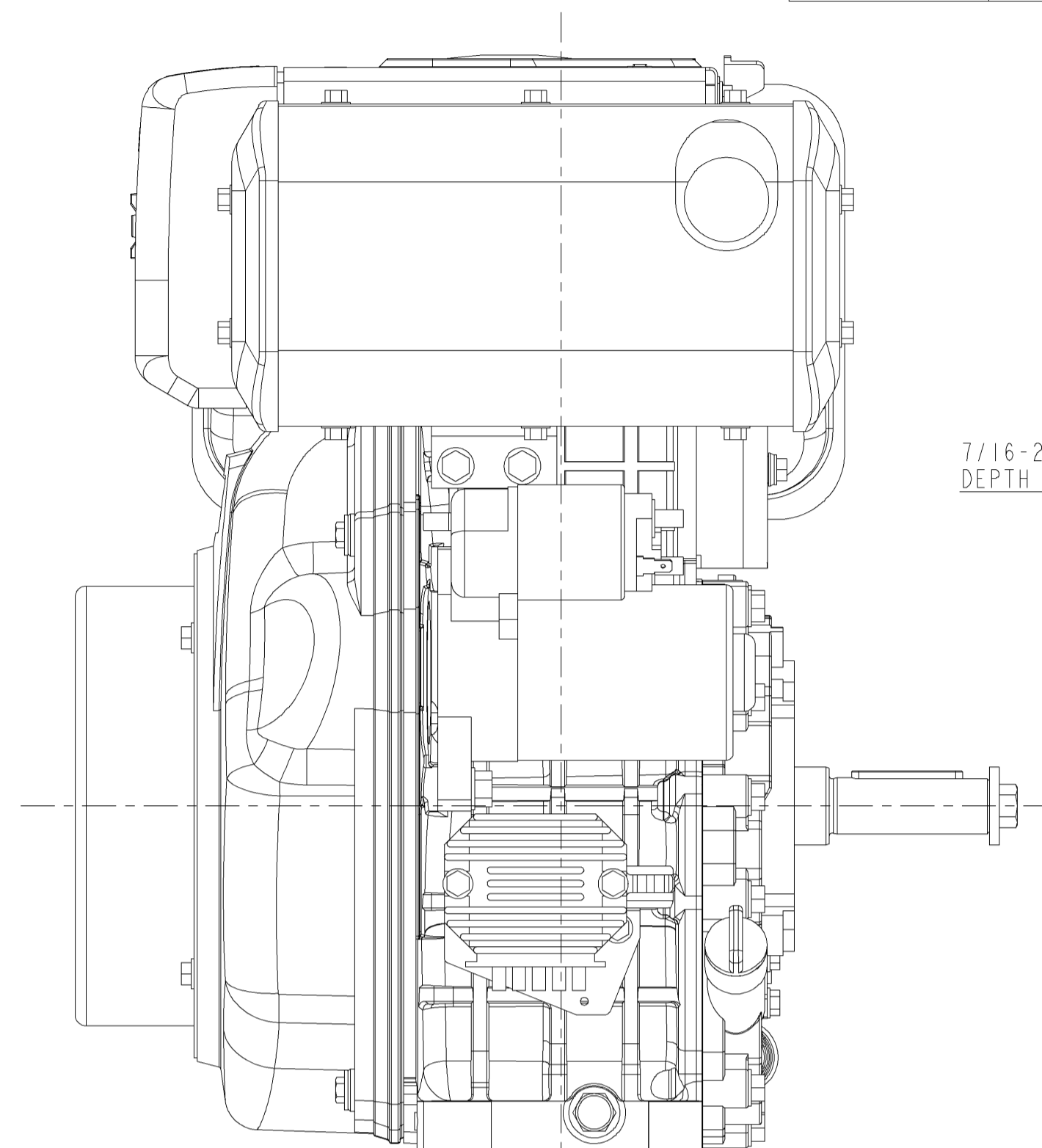
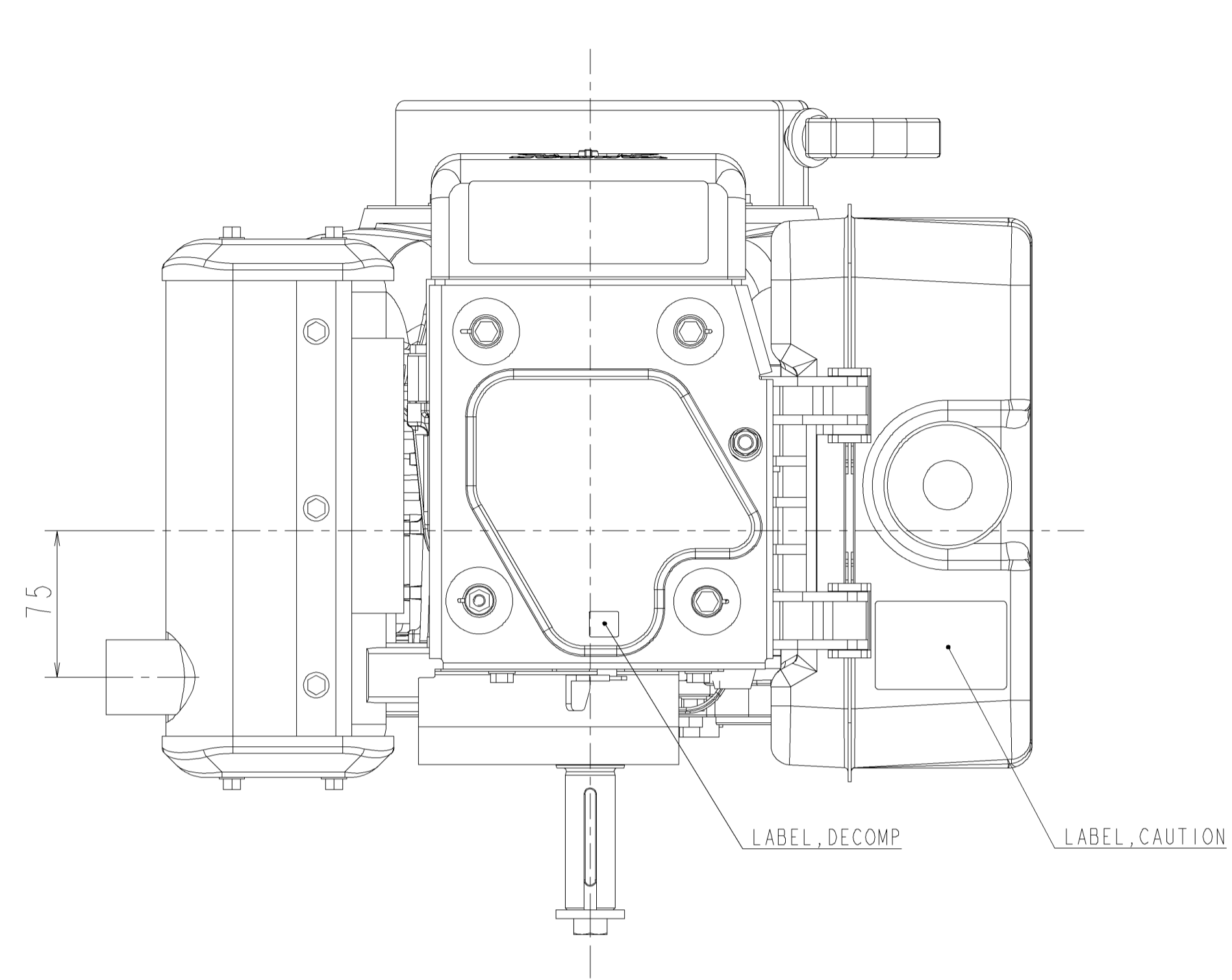

ENGINE MOUNTING PLATE AND PTO SHAFT SEEN THROUGH FROM THE TOP OF THIS ENGINE

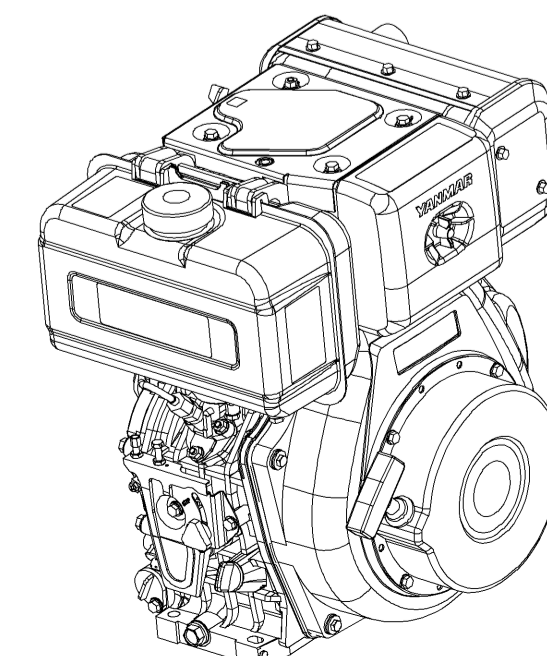
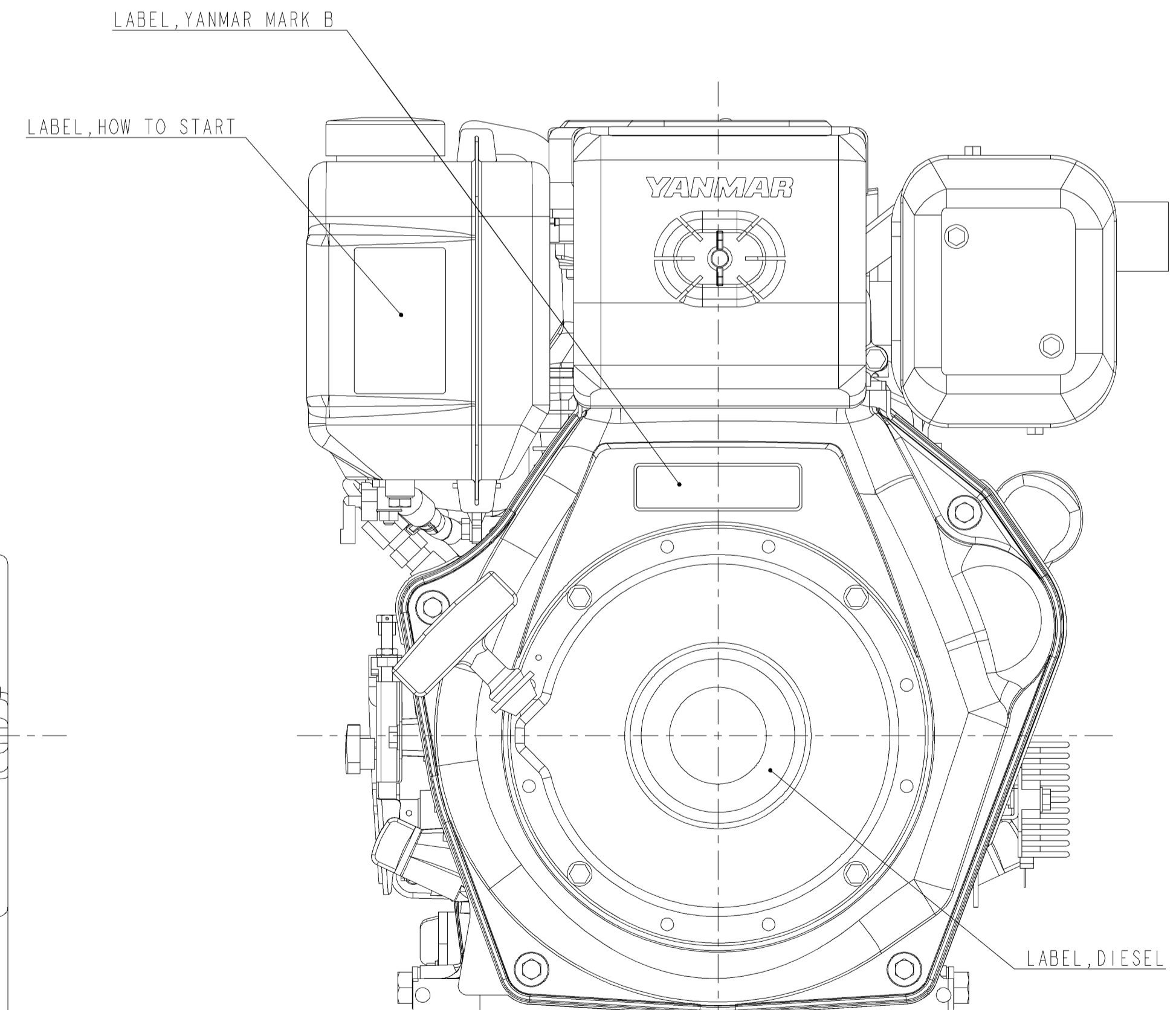
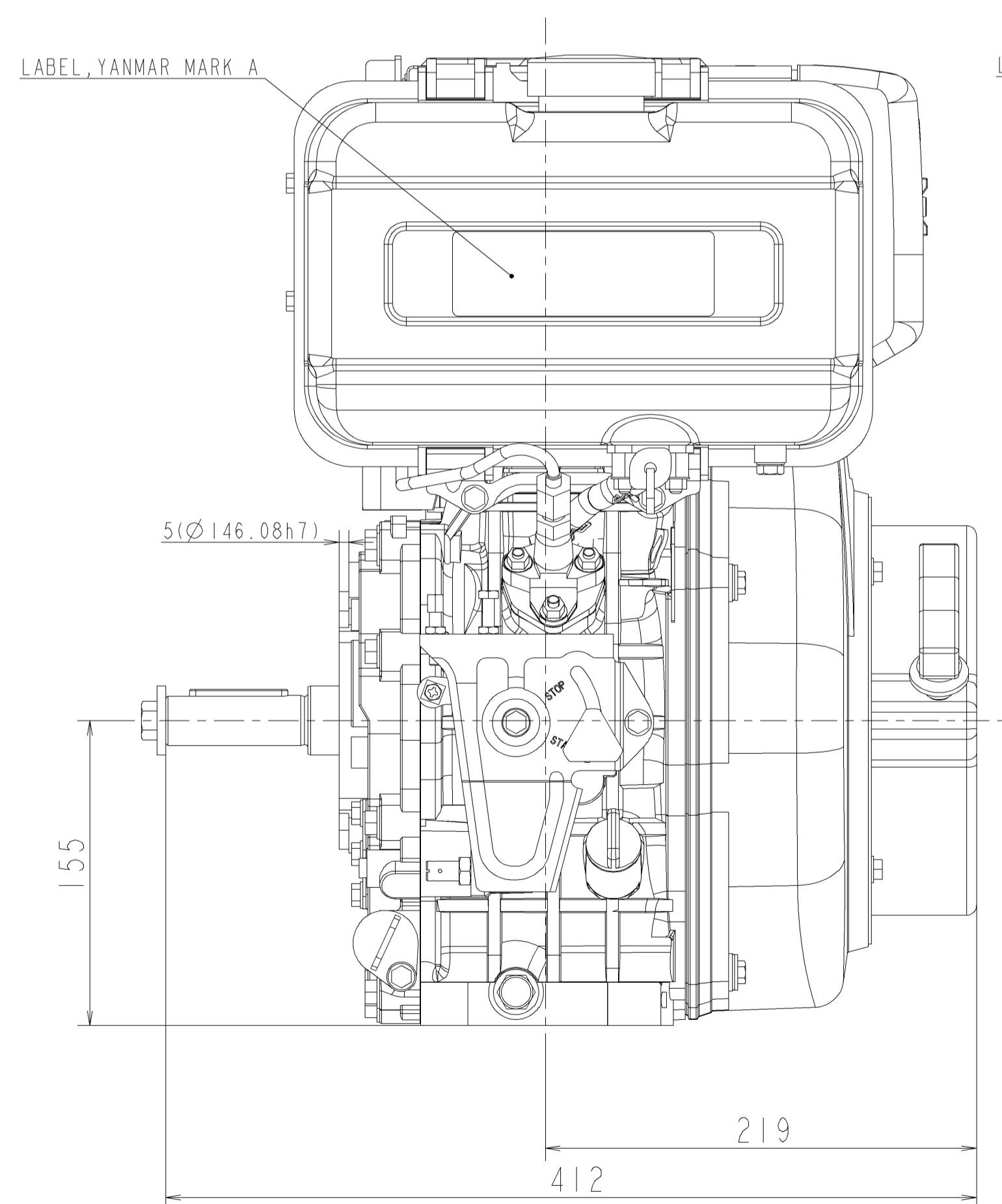
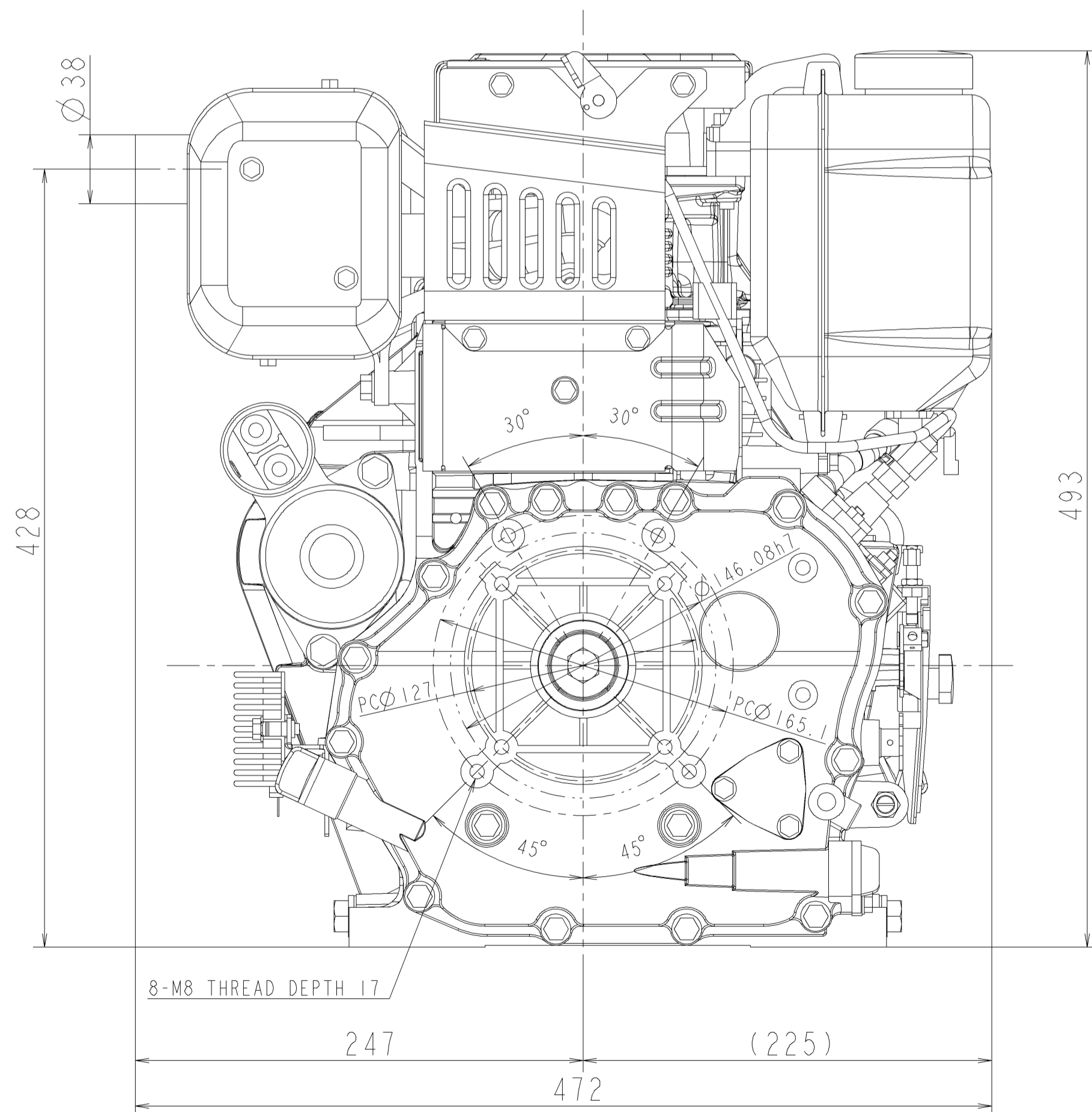

3D-CAD

NOTICE	
GEOMETRICAL TOLERANCE	
KIND OF TOLERANCE	SYMBOL
STRAIGHTNESS TOLERANCE	
CIRCULARITY TOLERANCE	○
PROFILE OF LINE TOLERANCE	⌒
FLATNESS TOLERANCE	∩
CYLINDRICITY TOLERANCE	∩
PROFILE TOLERANCE OF SURFACE	∩
PARALLELISM TOLERANCE	
PERPENDICULARITY TOLERANCE	⊥
ANGULARITY TOLERANCE	∠
POSITIONAL TOLERANCE	⊕
SURFACE TEXTURE TOLERANCE	∩
SYMMETRY TOLERANCE	∩
CHIRALITY TOLERANCE	∩
CHIRALITY TOLERANCE	∩

WEIGHT (RAW)	kg (±%)			G. MANAGER	MANAGER
WEIGHT (CALC.)	kg (±%)			J. SAMO	
SEC. MANAGER		MODEL	SCALE		FREE
J. SAMO		QTY	MATERIAL		
CHECKED	SPECIALIST	OUTLINE			
DESIGNED	DRAWN	DATE: Y. M. D	NAME		
S. NISHIMURA	H. OGAWA	22 NOV. 2005	LI00N6CAITIAA OUTLINE		
YANMAR			CODE	B2-14320-0010	DRAW SIZE
			YANMAR CO., LTD. ENGINE PRODUCT OPERATIONS DIV.		AI

LABELS

G2-14220-2010

No.	L A B E L S	P L A C E	C O N T E N T S
1	LABEL, ENGINE NAME	COVER (CYLINDER	—————
2	LABEL, YANMAR MARK (A	F. O. TANK	THE FOLLOWING DETAILS
3	LABEL, CAUTION	F. O. TANK	//
4	LABEL, HOW TO START	F. O. TANK	//
5	LABEL, YANMAR MARK (B	FANCASE, COOLING	//
6	LABEL, DIESEL	RECOIL STARTER	//
7	LABEL, DECOMP	COVER, TOP	//

② LABEL, YANMAR MARK (A



⑤ LABEL, YANMAR MARK (B



③ LABEL, CAUTION

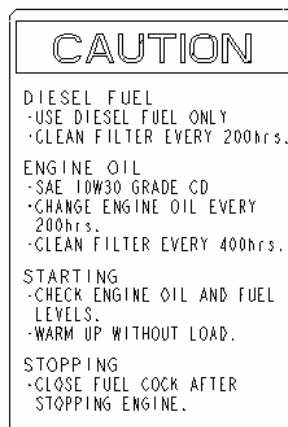

⑥ LABEL, DIESEL

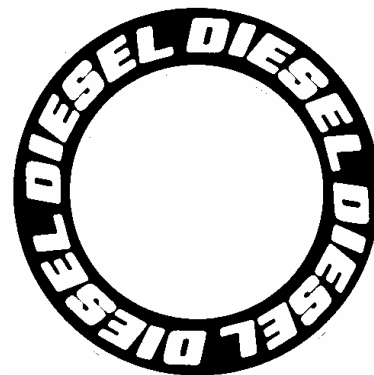

④ LABEL, HOW TO START



⑦ LABEL, DECOMP

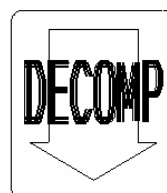

標準工具 TOOLS

C2-14110-0010

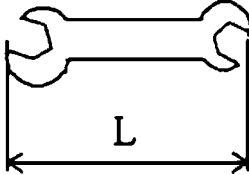
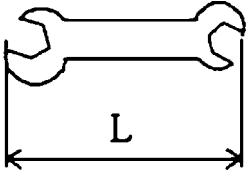
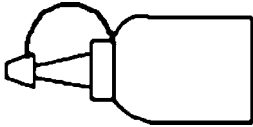
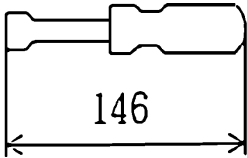
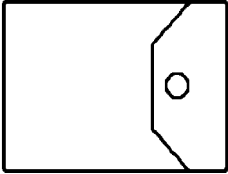
区分 ITEM	名称 DESCRIPTION	部品コード及び略図 PART NUMBER	材質 MATERIAL	個数 Q'ty	備考 NOTES
1	両口スパナ WRENCH 14×17	114299-92720 	UNI EN 10083/1 C40	1	L=163
2	両口スパナ WRENCH 10×12	114299-92710 	UNI EN 10083/1 C40	1	L=128
3	油さし FEEDER, OIL	114299-92740 	合成樹脂 POLYETHYRENE	1	
4	+-ねじまわし SCREWDRIVER	114299-92730 	UNI EN 10083/1 C40 & 合成樹脂 PVC	1	
5	工具袋 BAG, TOOL	114299-92600 	黒色ビニール PVC	1	

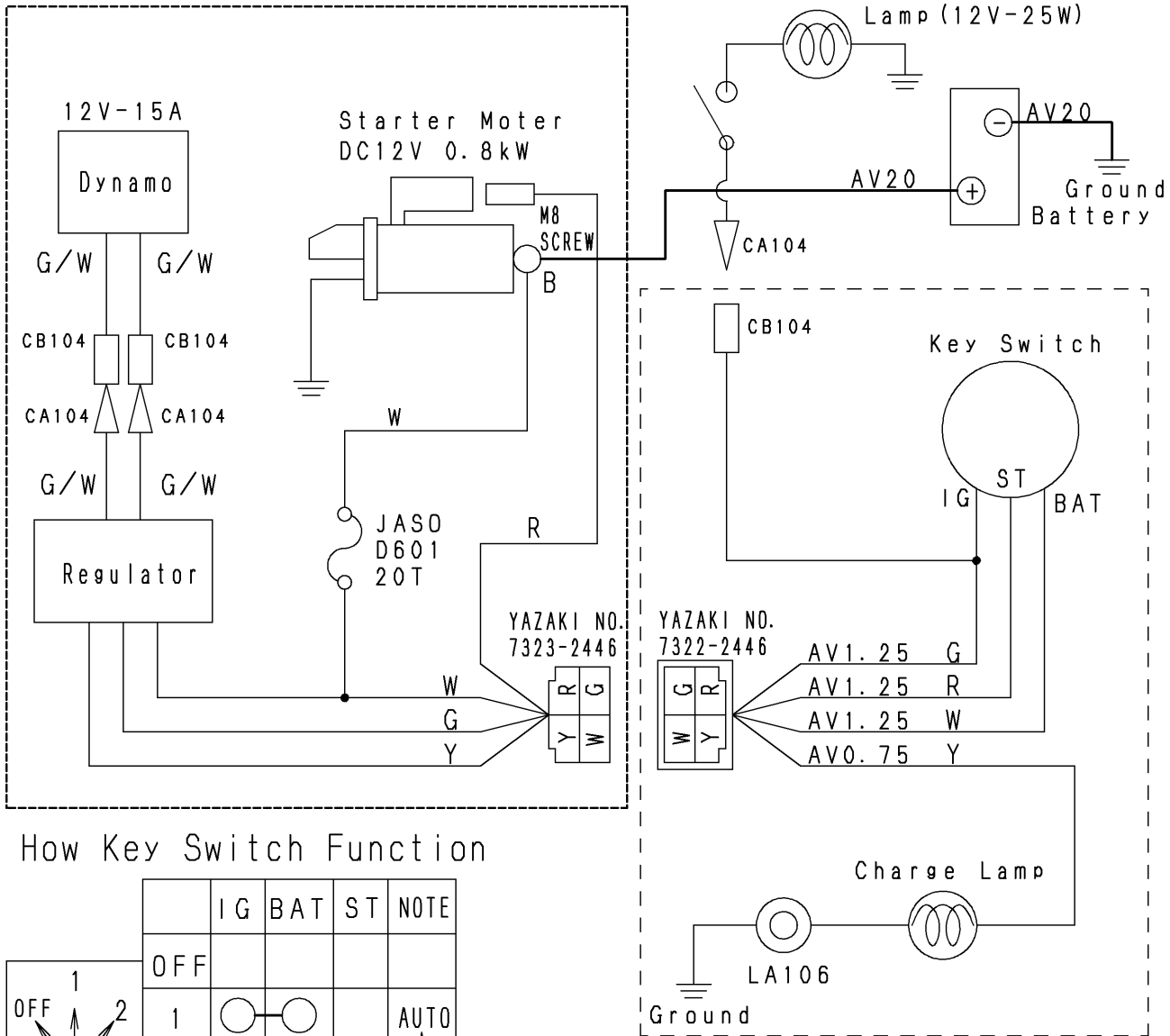

How Key Switch Function

	IG	BAT	ST	NOTE
OFF				
1	○—○			AUTO
2	○—○—○			↑

* G:Green
W:White
Y:Yellow
R:Red

NOTE:

1. Be sure to ground both engine and engine-driven machine
2. Section enclosed with dotted square is pre-wired at Yanmar factory.
Section enclosed with alternate long and short dash line is the section included in engine packing.
For this section, purchaser is expected to:
 - 1) connect 4P coupler.
 - 2) secure charge lamp ground (LA106) with bolt (M6)
 - 3) Receptacle of pin-type terminal (CB104) outputs up to 12V/25W.
3. Locally procure
 - 1 battery (24AH-36AH)
 - 2 battery cable (AV20)
 - 3 lamp (12V-25W), switch and cable (AV1.25)