

REPAIR GUIDELINE

Hedge Trimmer_HT5100E/HT6500E



Version: 1

Issue Date: 2016/12/02

Table of Contents

HT5100E/HT6500E Hedge Trimmer

NO.	Contents	Page
1	Troubleshooting	3
2	Tool List	4
3	Replacing the Front Handle Set	5-13
4	Replacing the Blade Assembly	14-25
5	Replacing the PCB Assembly	26-41
6	Replacing the Motor and Gear Box ASSY.	42-49
7	Repairs to the Gear Box	50-62

Problem	Possible Cause	Fault Position	Test & Solution
Fail to start	Main PCB or its wires are broken	PCB Assembly	Replace the PCB assembly.
	The blade is jammed when an obstruction is stuck in the blade and deforming the blade.	Blade Set	Clear any obstructions or replace the blade Set
	Motor failure	Motor	Replace the motor and gear assembly.
	Gears are jammed due to damaged teeth.	Gear Set	Replace the failure gears.
	Malfunction of switch levers	Switch Levers	Replace the switch lever.
Soft start failure	Main PCB is broken	PCB Assembly	Replace the PCB assembly.
Excessive vibration	worn eccentric block, gears or shaft	Eccentric Block, Gears, Shaft	Replace the worn parts
The speed and power is less compared with normal use.	Motor is broken	Motor	Replace the motor and gear assembly.
The switch lever doesn't return to the original position.	Dust stuck in the switch.	Switch Lever	Clear the dust

Tool List For Repair

HT5100E/HT6500E Hedge Trimmer

NO.	Tool List	SPEC	Remark
1	Magnetic tool Bits		
2	Hexagon Lobular Screwdriver		To remove the hexagon lobular screw
3	Screwdriver		
4	Torque Wrench	Rated torque should exceed 12 Nm	To tighten the blade bolt
5	Hex wrench	5mm	
6	Electric Soldering Iron		To solder or separate the motor from the PCB
7	Solder Sucker		
8	Heat Shrinkable Sleeves		
9	Scissors		To remove the shrinkable sleeve
10	Hot Air Gun		To shrink the shrinkable sleeves
11	Oil and Grease		To lubricate the blade and gears
12	Inside Caliper		To remove the circlip

Part 1: Replacing the Front Handle Set

Replacing the Front Handle Set

HT5100E/HT6500E Hedge Trimmer

1. Loosen and remove the two hexagon screws in the guard and remove the guard from the housing.
2. Replace the guard if it is broken.



Front Handle



Guard

Hexagon Screw

Description	Old Part Number	New Part Number	Qty
Hexagon Screw	5610264001	/	2
Guard	2824847001	3128263001	1

Replacing the Front Handle Set

HT5100E/HT6500E Hedge Trimmer

- Loosen and remove the 6 self tapping screws from the front handle.
- Loosen the 4 hexagon socket screws with their washers at either side of the front handle set and remove them.
- Separate the front half from the rear half of the handle.



6pcs Self Tapping Screw



4 Hexagon Socket Screws



Front Half Handle

Description	Old Part Number	New Part Number	Qty
Self Tapping Screw	5610032004	/	6
Hexagon Socket Screw	5620446003	5620446004	4
Washer	5650404001	/	4

Replacing the Front Handle Set

HT5100E/HT6500E Hedge Trimmer

- Remove the internal wires and front switch from the rear half of the handle, separate the rear half handle from the front handle.

NOTICE: If the serial number of Hedge Trimmer is from EHT02160300001 to EHT02160400500 , replace all the parts in front handle set, including front switch, spring, front switch trigger and front handle set following the slides from 10 to 13.

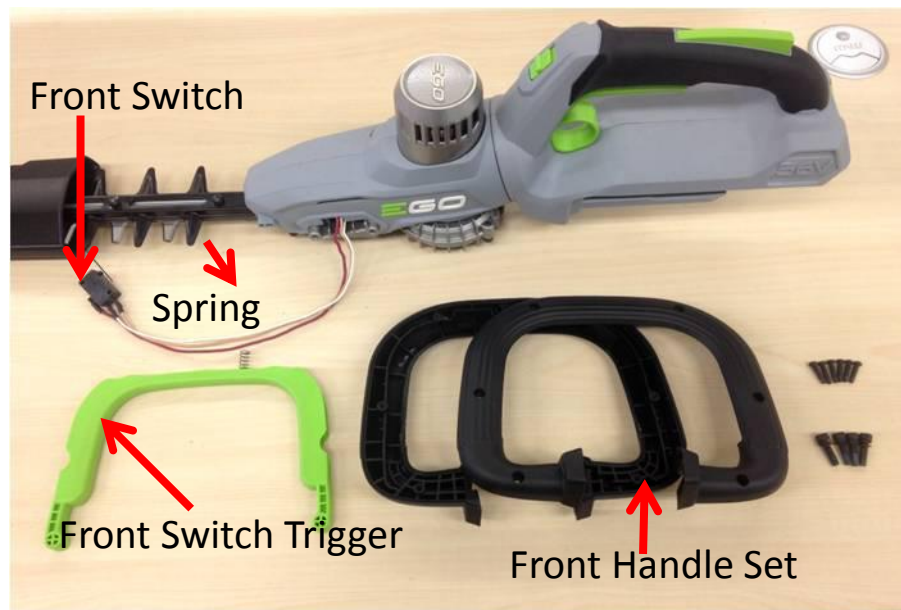

Description	Part Number
Front Handle Set	2824552001
Front Switch Trigger	3128269001
Spring	3660046001

Replacing the Front Handle Set

HT5100E/HT6500E Hedge Trimmer

6. Remove the internal wires and front switch from the rear half of the handle, separate the rear half handle from the front handle.

NOTICE: If the serial number of Hedge Trimmer is not between EHT02160300001 to EHT02160400500 , replace or repair the damaged part.

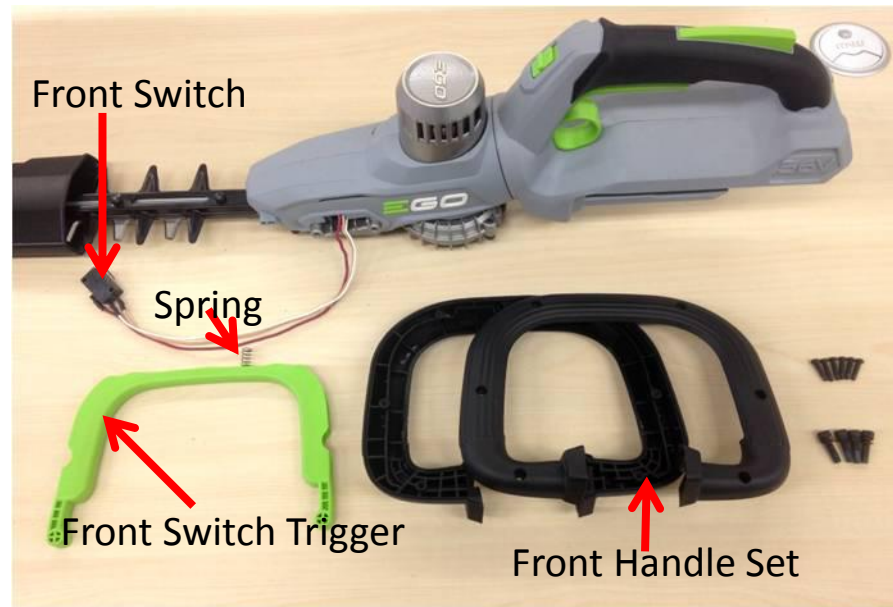

Description	Part Number
Front Handle Set	2824552001
Front Switch Trigger	3128269001
Spring	3660046001

Replacing the Front Handle Set

HT5100E/HT6500E Hedge Trimmer

7. Replace the front handle set if broken.
8. To replace the front switch:
 - (a) Remove the heat-shrinkable sleeves with a scissor, then separate the wires from the trigger using an electric soldering iron.
 - (b) Replace with a new switch.
 - (c) Place new heat-shrinkable sleeves through the wires, then solder the wires to the switch following the figure below.
 - (d) Move the heat-shrinkable sleeves to cover the switch feet and use a hot air gun to shrink the

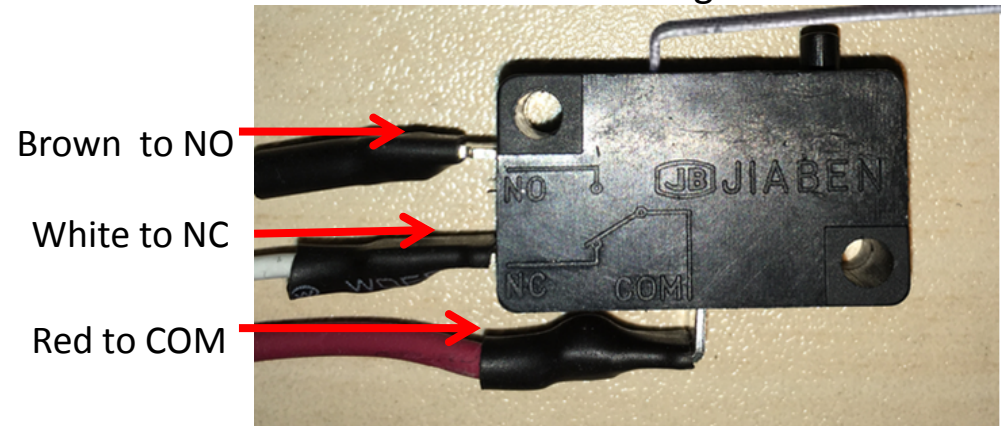

Brown to NO

White to NC

Red to COM

Description	Part Number
Front Switch	4870564001

Replacing the Front Handle Set

HT5100E/HT6500E Hedge Trimmer

9. Mount the rear half handle to the housing.
10. Position the switch into the locating pin in the rear half handle as the figure shows below.

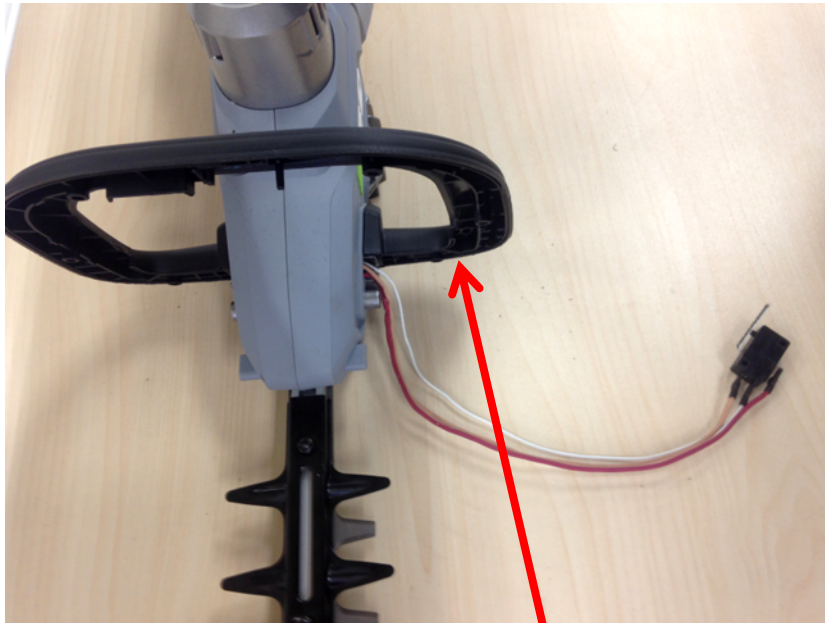

Rear Half Handle

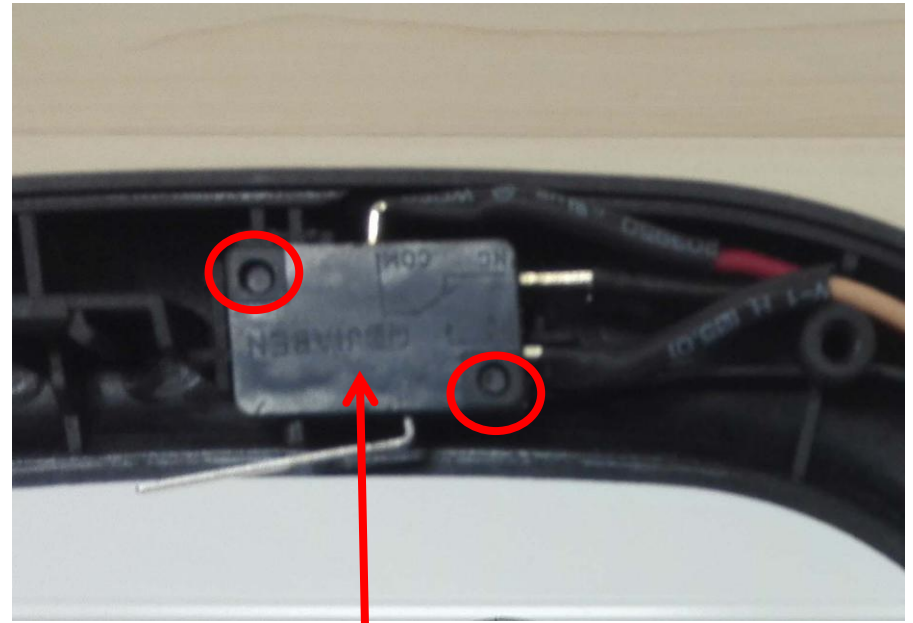

Front Switch

Replacing the Front Handle Set

HT5100E/HT6500E Hedge Trimmer

11. Align the internal wires in the handle grooves, make sure the brown wire is on the top and white wire is in the bottom.
12. Fit the spring to the green trigger and mount the trigger into the rear half handle.

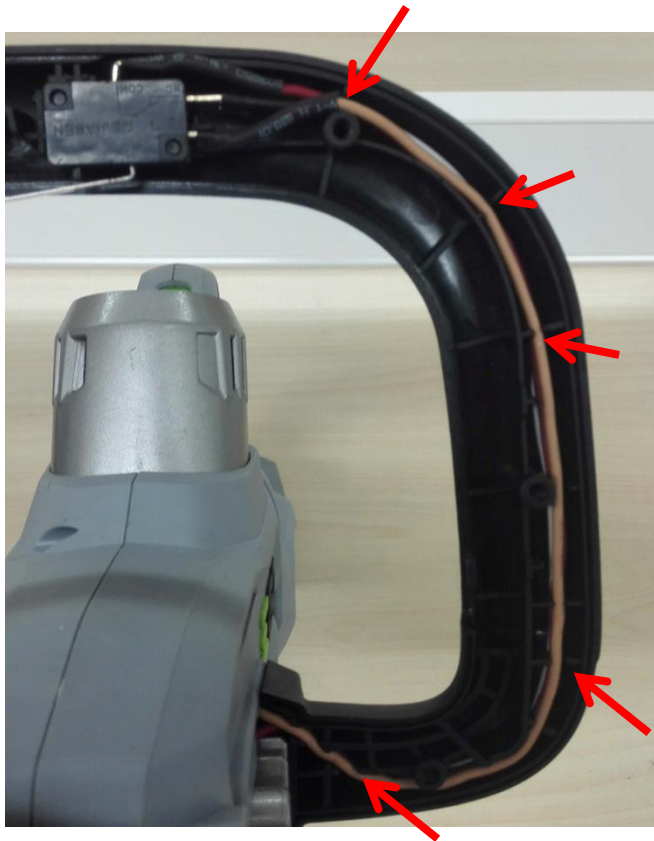

The Part with Spring

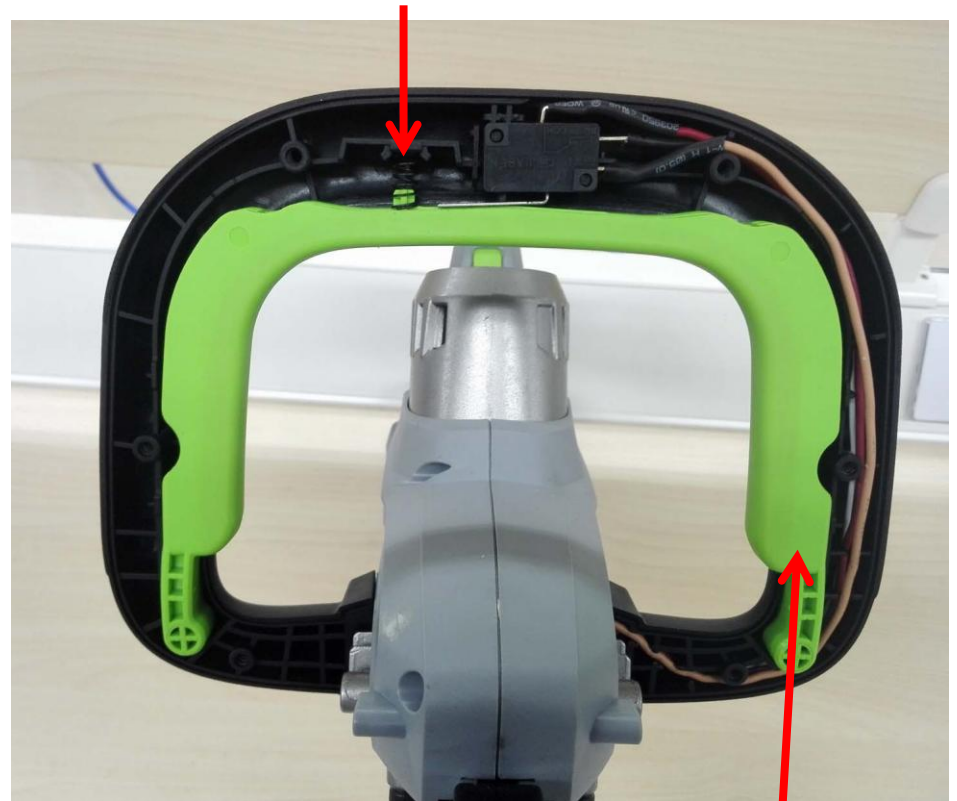

Front Switch Trigger

Replacing the Front Handle Set

HT5100E/HT6500E Hedge Trimmer

13. Assemble the front handle and tighten it with the 6 self tapping screws with a torque of 1.1~1.3Nm .
14. Assemble the front handle on the housing with the 4 hexagon screws with a torque of 2~2.5Nm.
15. Mount the guard onto the housing and lock it with the 2 hexagon screws, the torque required is 1.1~1.3Nm.



Part 2: Replacing the Blade Assembly

Replacing the Blade Assembly

HT5100E/HT6500E Hedge Trimmer

1. Use a 5mm hex wrench to remove the 6 hexagon screws in the lower housing assembly and remove the lower housing assembly.

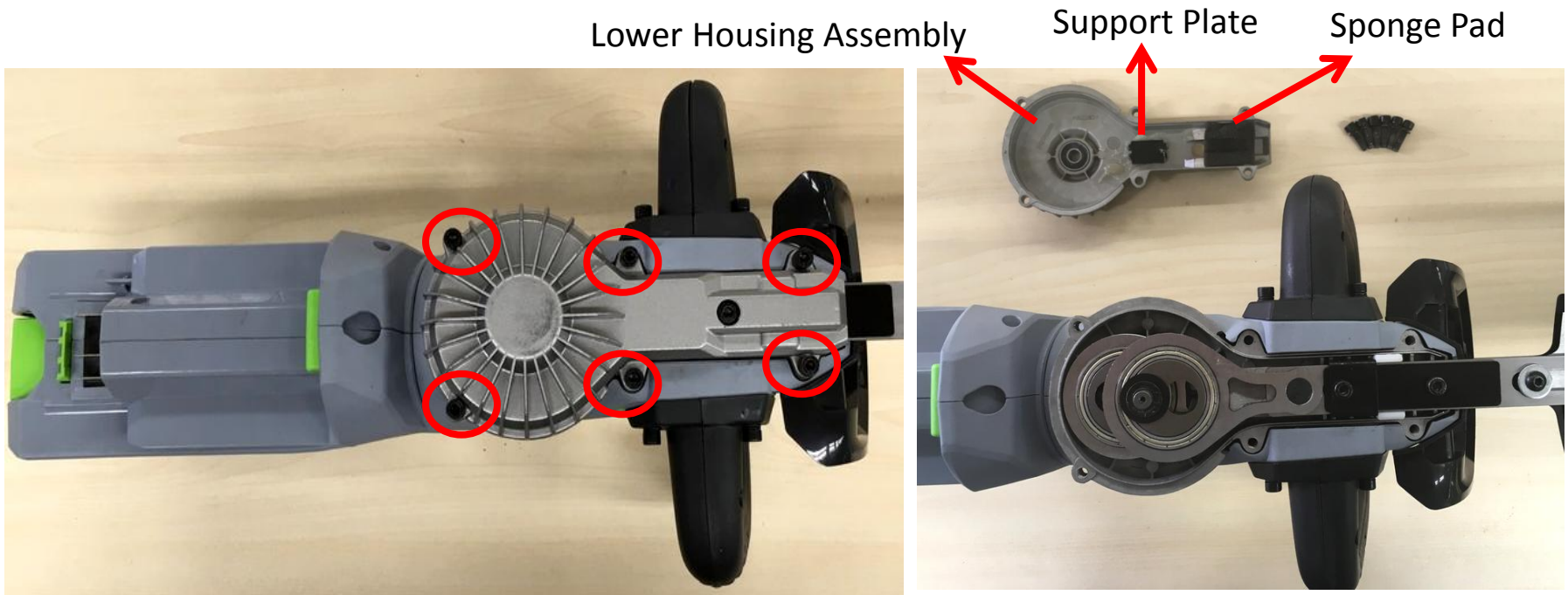

Description	Old Part Number	New Part Number	Qty
Lower Housing Assembly	2824560001	/	1
Support Plate	3706095001	/	1
Sponge Pad	3705994001	/	1
Hexagon Socket Screw	5620446003	5620446004	6

Replacing the Blade Assembly

HT5100E/HT6500E Hedge Trimmer

2. Use an inside caliper to remove the circlip which is on the shaft and remove the two washers.
3. Remove the link assembly from the eccentric block.

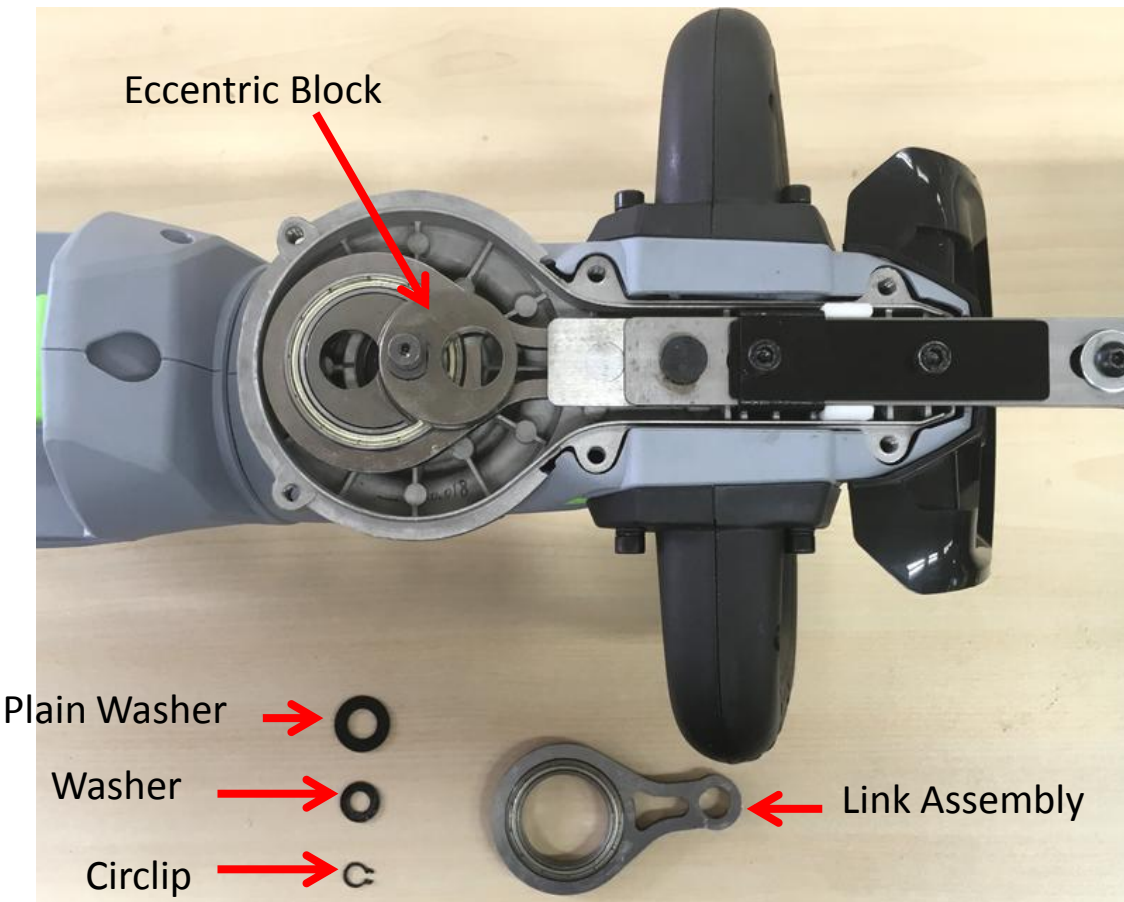

Description	Part Number
Plain Washer	5650551001
Washer	3700155002
Circlip	5660007001
Link Assembly	2824561001
Eccentric Block	3552450001

Replacing the Blade Assembly

HT5100E/HT6500E Hedge Trimmer

- Loosen the two hexagon screws on the blade and remove the 2pcs hexagon screws, upper support plate and support plate from the blade.

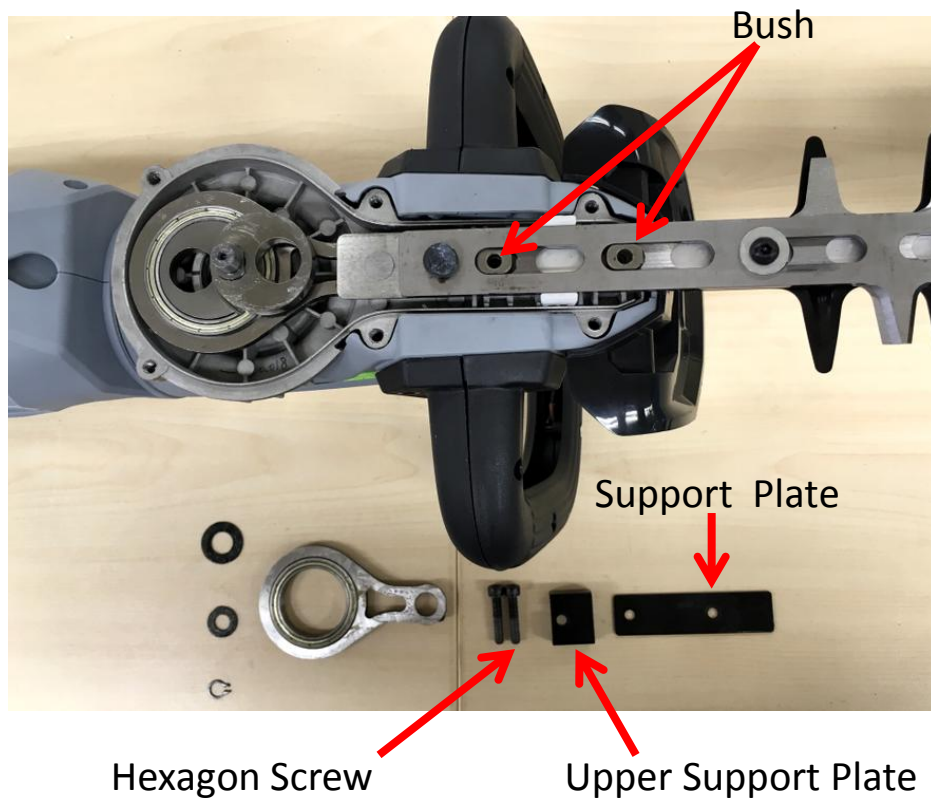

Description	Part Number	Qty
Hexagon Screw	5620216005	2
Upper Support Plate	3706098001	1
Support Plate	3705991001	1
Bush	5650531001	2

Replacing the Blade Assembly

HT5100E/HT6500E Hedge Trimmer

5. Remove the two bushes out of the blade set and remove the blade set.
6. Replace the blade set and other parts if they are worn or broken.

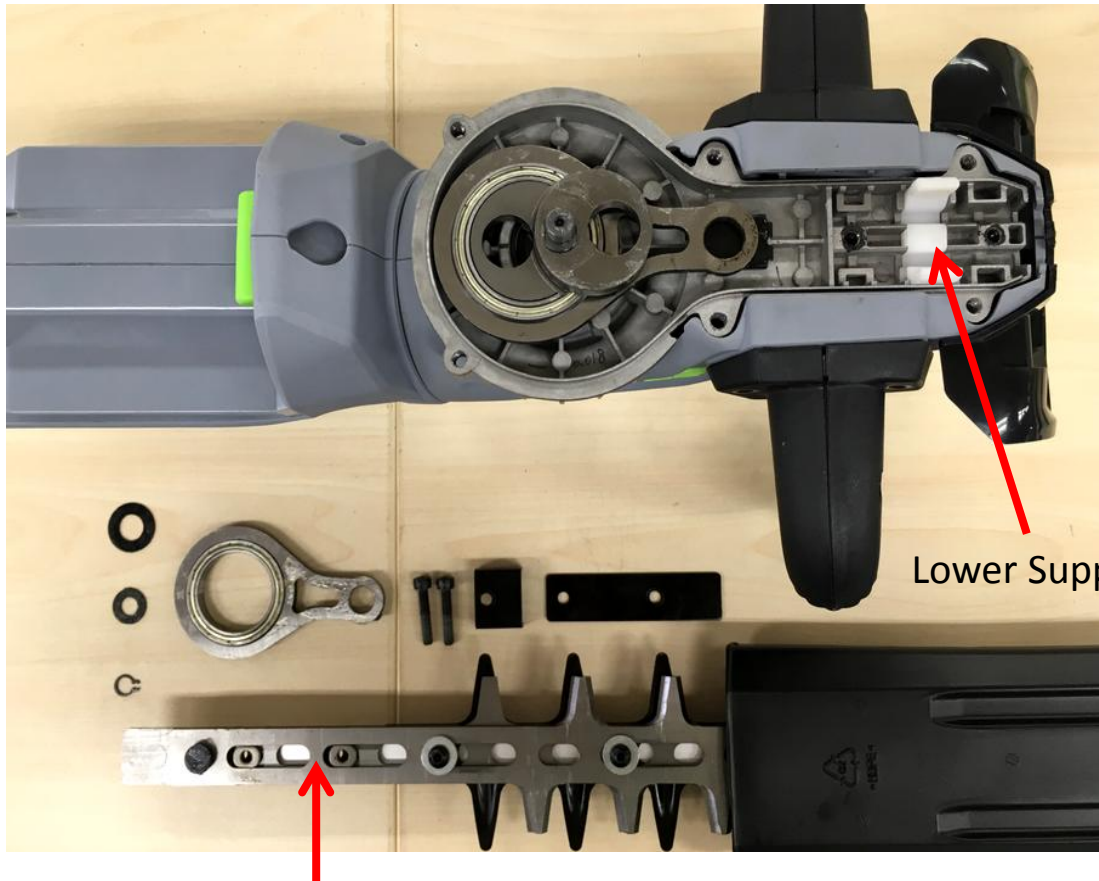

Description	Part Number
Blade Set	2824519001
Lower Support Plate	3126835001

Blade Set

Lower Support Plate

Replacing the Blade Assembly

HT5100E/HT6500E Hedge Trimmer

- Loosen the 6 nuts on the blade assembly to remove the protective teeth, tip protector, replace the parts if they are worn or broken.

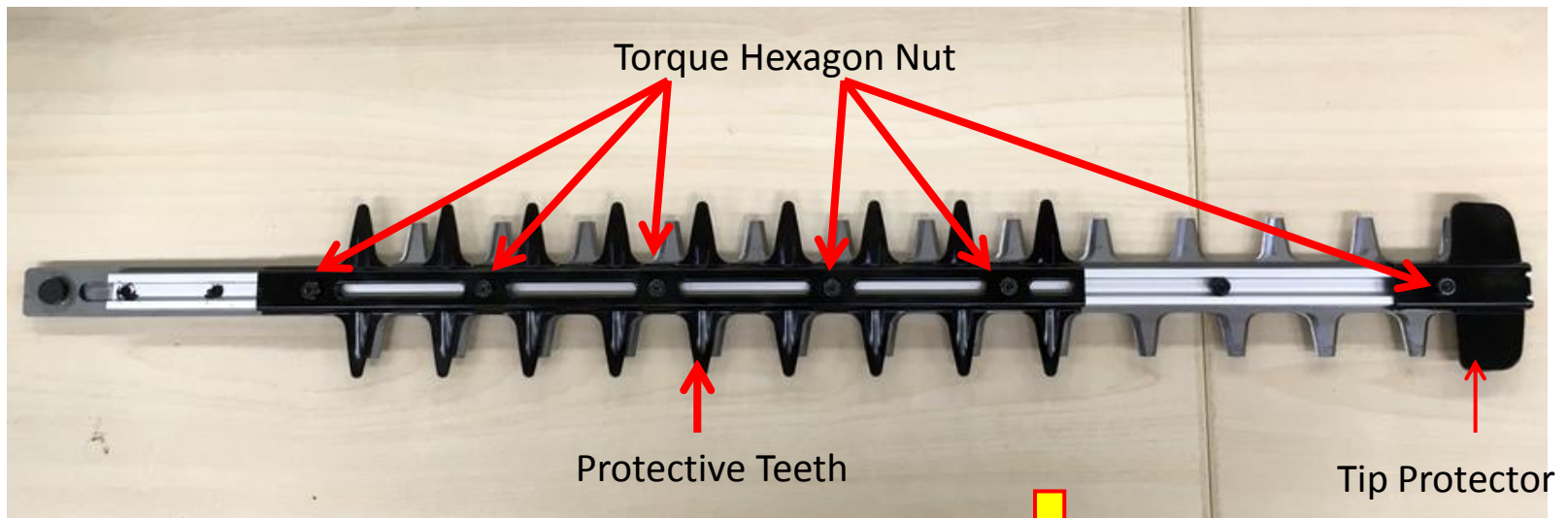

Description	Part Number	Qty
Tip Protector	3705992001	1
Protective Teeth	3706043001	1
Nut	5630007006	13



Replacing the Blade Assembly

HT5100E/HT6500E Hedge Trimmer

- Loosen the 6 hexagon screws 1# and the one hexagon screw 2# out of the blade assembly and remove the blade, support plate, clamp plate in turn, Replace any parts if they are worn or broken.

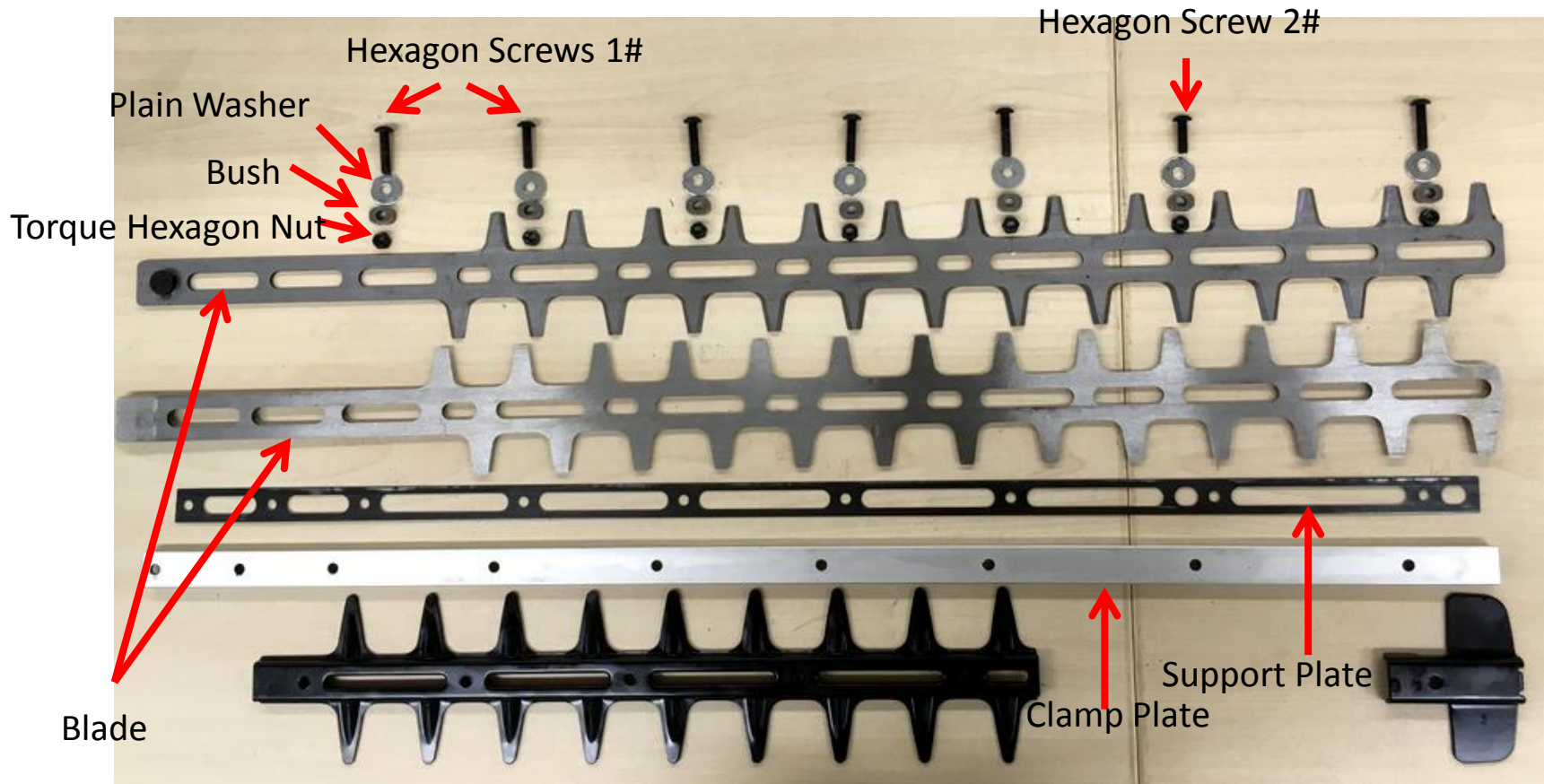

Replacing the Blade Assembly

HT5100E/HT6500E Hedge Trimmer

9. Put the support plate, blade on the clamp plate in turn, mount the 6 hexagon socket screws 1# and the one hexagon socket screw 2# with a torque of 3.4~3.6Nm.

NOTICE: Keep the burr surface on the clamp plate .

10. Mount the tip protector, protective teeth and fix them with 6 nuts with a torque of 2~2.5Nm .

Description	Part Number	Qty
Bush	5650531001	7
Plain Washer	5650487001	7
Hexagon Screw 1#	5620544001	6
Hexagon Screw 2#	5620543001	1

HT5100E Hedge Trimmer		
Description	Part Number	Qty
Blade set	2824519001	1
Clamp Plate	3552477001	1
Support Plate	3706079001	1
Blade	3706078001	2

Replacing the Blade Assembly

HT5100E/HT6500E Hedge Trimmer

NOTICE: The difference between HT5100E and HT6500E is the length of the blade as well as the number of the hexagon socket screws, bushes, washers and nuts on them. See below.



HT6500E Hedge Trimmer		
Description	Old Part Number	New Part Number
Blade Set	2824384001	2824384002
Clamp Plate	3551852001	/
Support Plate	3705999001	/
Blade	3705993001	/

Replacing the Blade Assembly

HT5100E/HT6500E Hedge Trimmer

11. Mount the lower support plate, blade set, link assembly, bushes, support plate and upper support plate in turn. **NOTICE:** Keep the bulge of the link assembly down and make sure that the blade set is well matched with the link assembly.

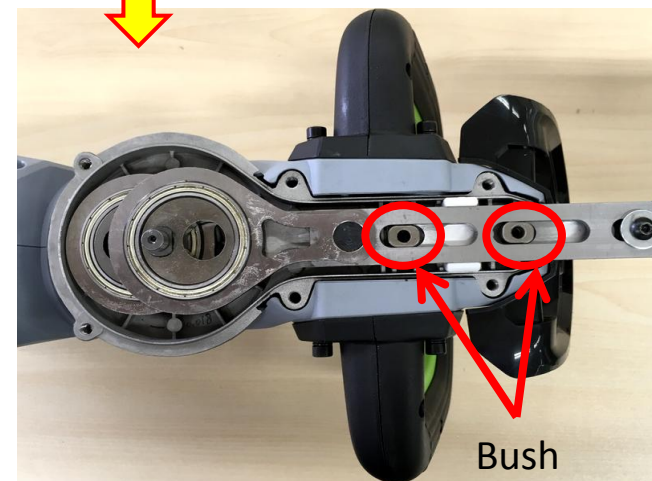
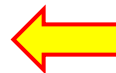
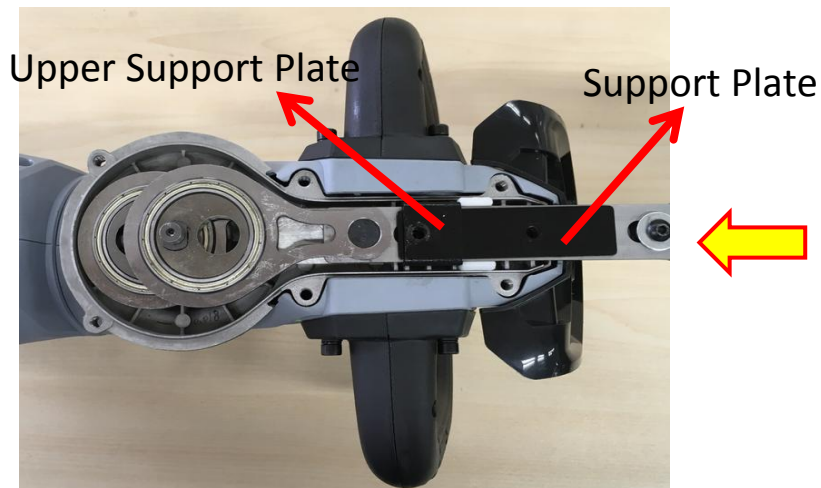
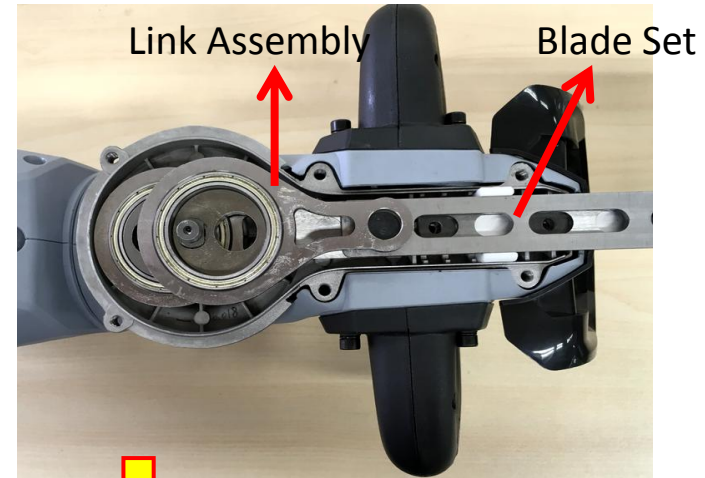
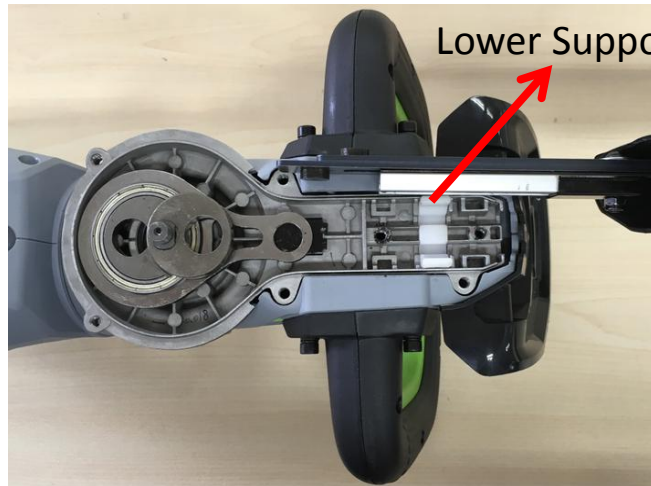

Replacing the Blade Assembly

HT5100E/HT6500E Hedge Trimmer

12. Mount 2pcs hexagon socket screws 1# with a torque of 4.5~5Nm. Use Loctite.
13. Mount the plain washer, washer and circlip in sequence.
14. Mount the lower housing Assembly and tighten 6pcs hexagon socket screws 2# with a torque of 2.5Nm

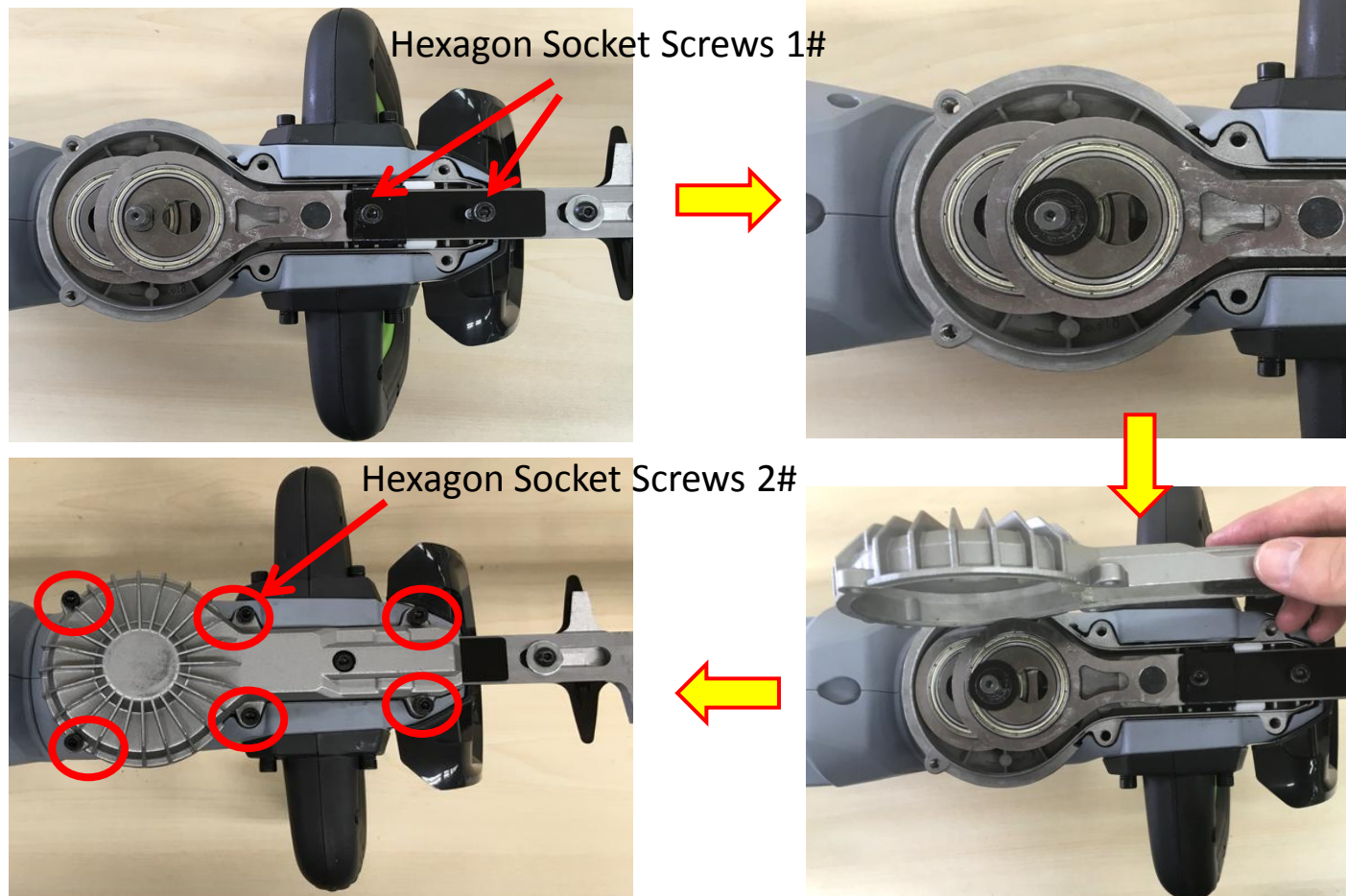

Replacing the Blade Assembly

HT5100E/HT6500E Hedge Trimmer

15. Install the battery, press the front trigger first then press the rear switch trigger. Test for proper operation for at least 30 seconds. If not, reassemble all the parts, making sure every step is correct.



Part 3: Replacing the PCB Assembly

Replacing the PCB Assembly

HT5100E/HT6500E Hedge Trimmer

1. Following the instructions for “**Replacing the Front Handle Set**” to remove the guard, front handle set.
2. Loosen and remove the 8 self tapping screws in the right rear handle and open the housing.
3. Loosen and remove the 5 self tapping screws in the right housing.



Replacing the PCB Assembly

HT5100E/HT6500E Hedge Trimmer

4. Remove the speed adjustment knob, lock off trigger, rear switch trigger, battery release button, latch, ejection lever, lock lever as well as the four springs.
5. Remove the PCBA from the left rear handle .

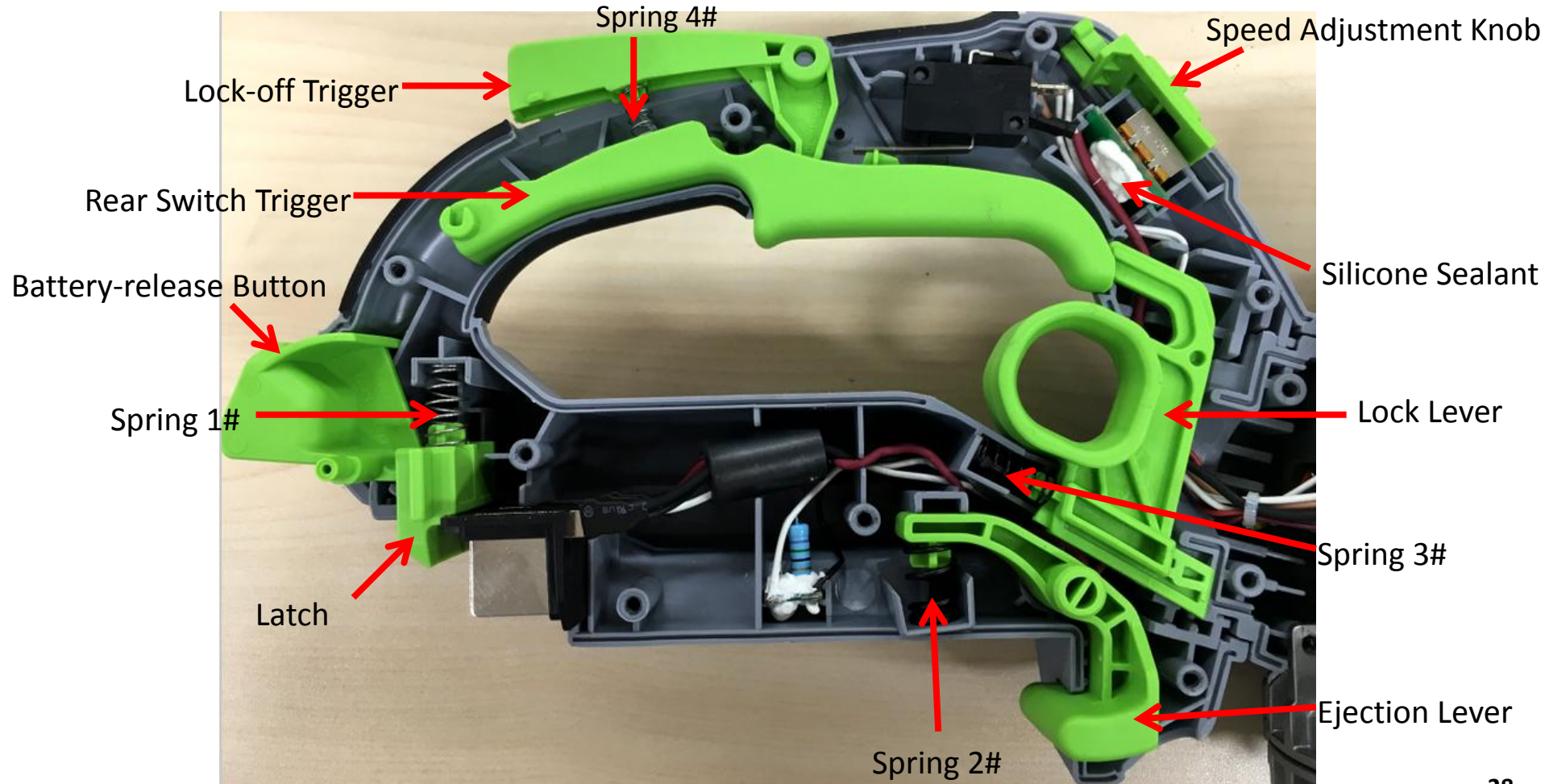

Replacing the PCB Assembly

HT5100E/HT6500E Hedge Trimmer

Description	Old Part Number	New Part Number
Rear Handle Set	2824556001	/
L R Housing Set	2824845001	2824553001
Lock off Trigger	3127212001	/
Rear Switch Trigger	3128270001	/
Battery Release Button	3127201001	/
Latch	3127202001	/
Ejection Lever	3128266001	/
Lock Lever	3128166001	/
Speed Adjustment Knob	3128276001	/
Spring 1#	3660013003	/
Spring 2#	3660614001	/
Spring 3#	3660072002	/
Spring 4#	3660088003	/
PCBA	2830118001	/

Replacing the PCB Assembly

HT5100E/HT6500E Hedge Trimmer

6. Remove the left rear handle(as well as the damping ring) and the left housing .

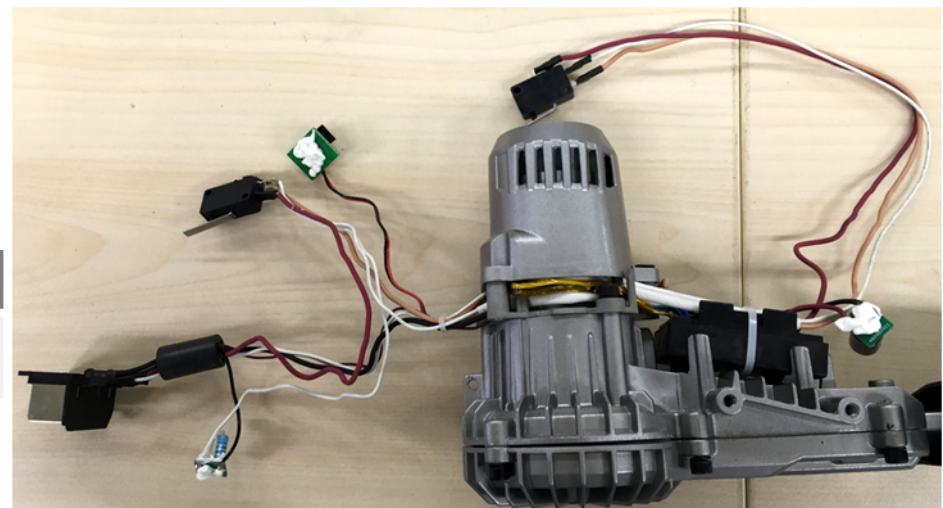
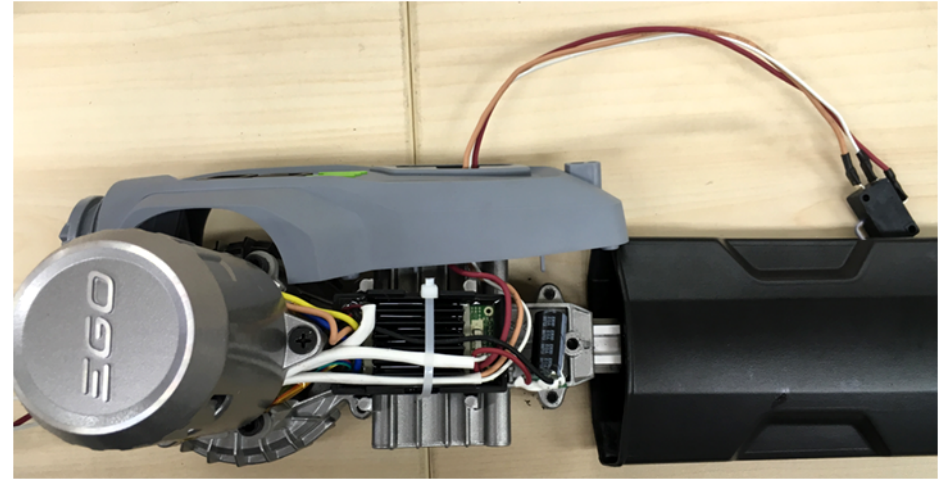
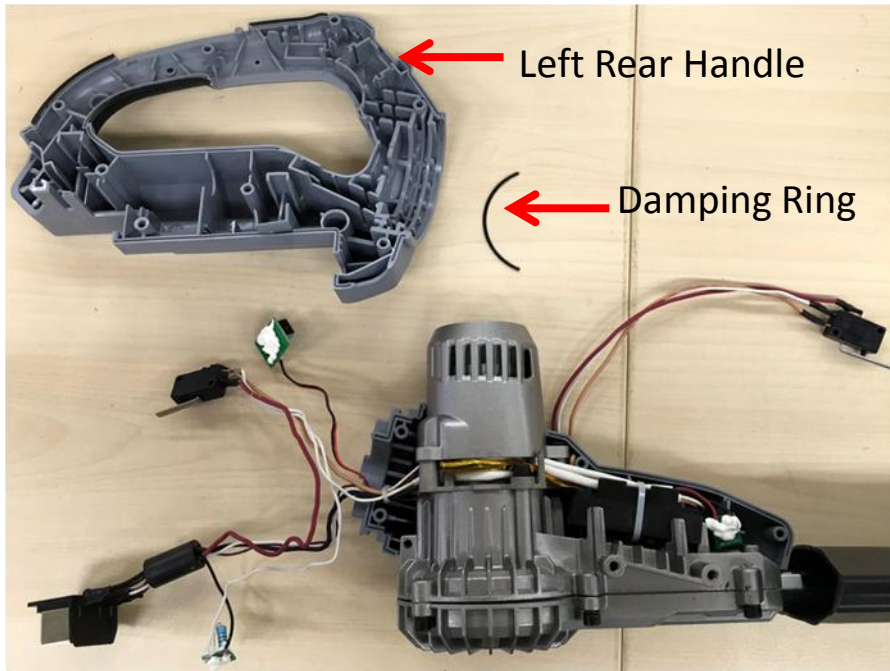

Description	Part Number
Damping Ring	5690350001

Replacing the PCB Assembly

HT5100E/HT6500E Hedge Trimmer

7. Loosen the 3 thread forming screws to remove the motor top cover.
8. Remove the silicone sealant and unlatch the plug softly from the outlet on the motor (Fig. 1.)

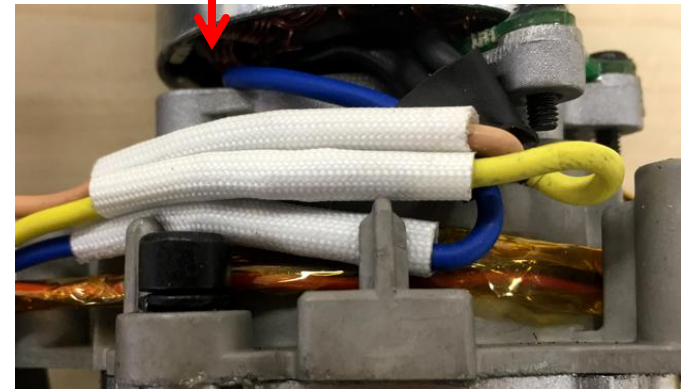
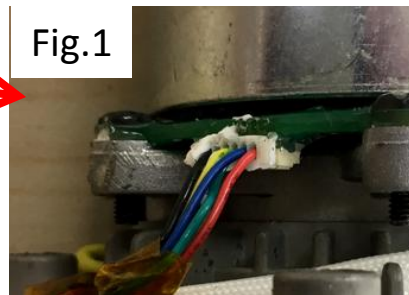
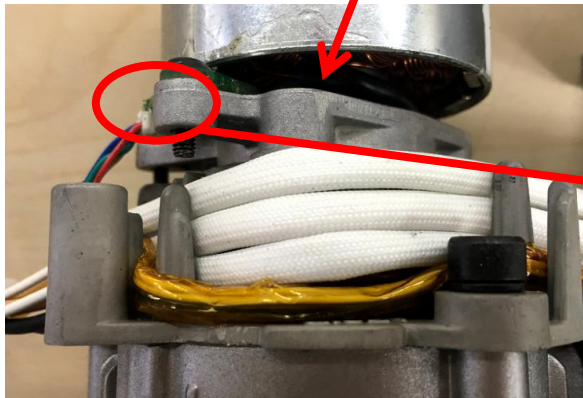
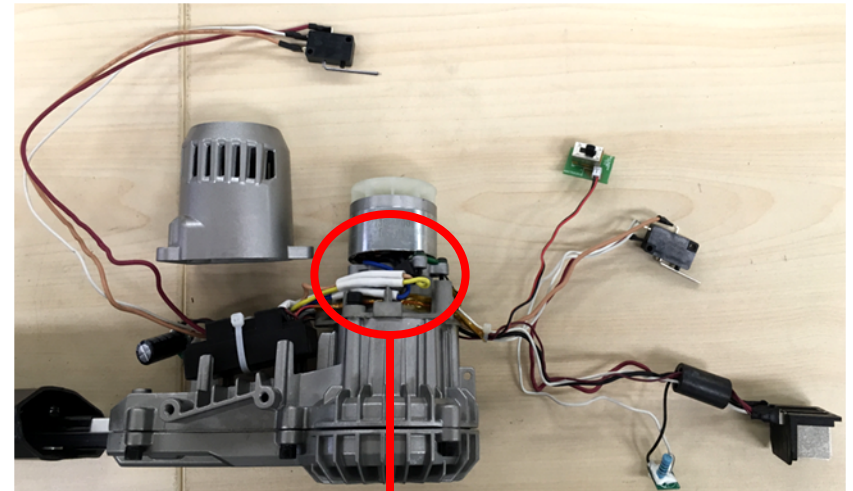
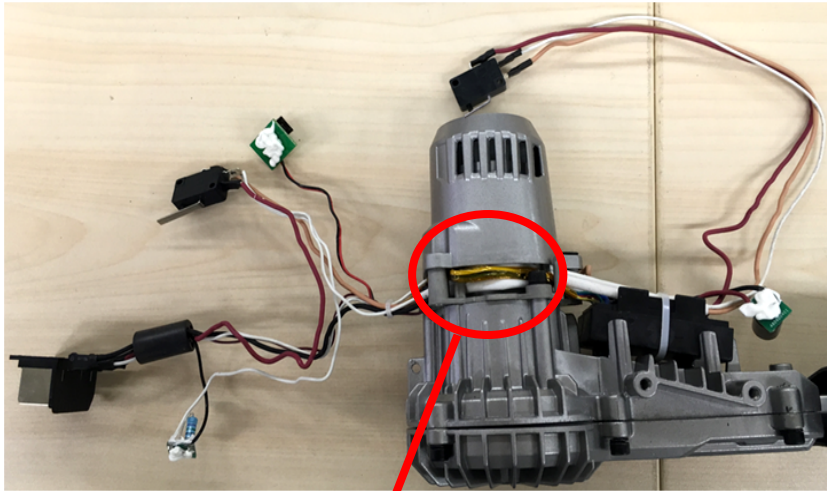

Replacing the PCB Assembly

HT5100E/HT6500E Hedge Trimmer

9. Remove the whole PCB assembly from the gear box assembly.
10. Remove the soft sleeves, remove the shrinkable sleeves with a scissor, disconnect the 3 solder joints with a electric soldering iron as indicated on the below figure.

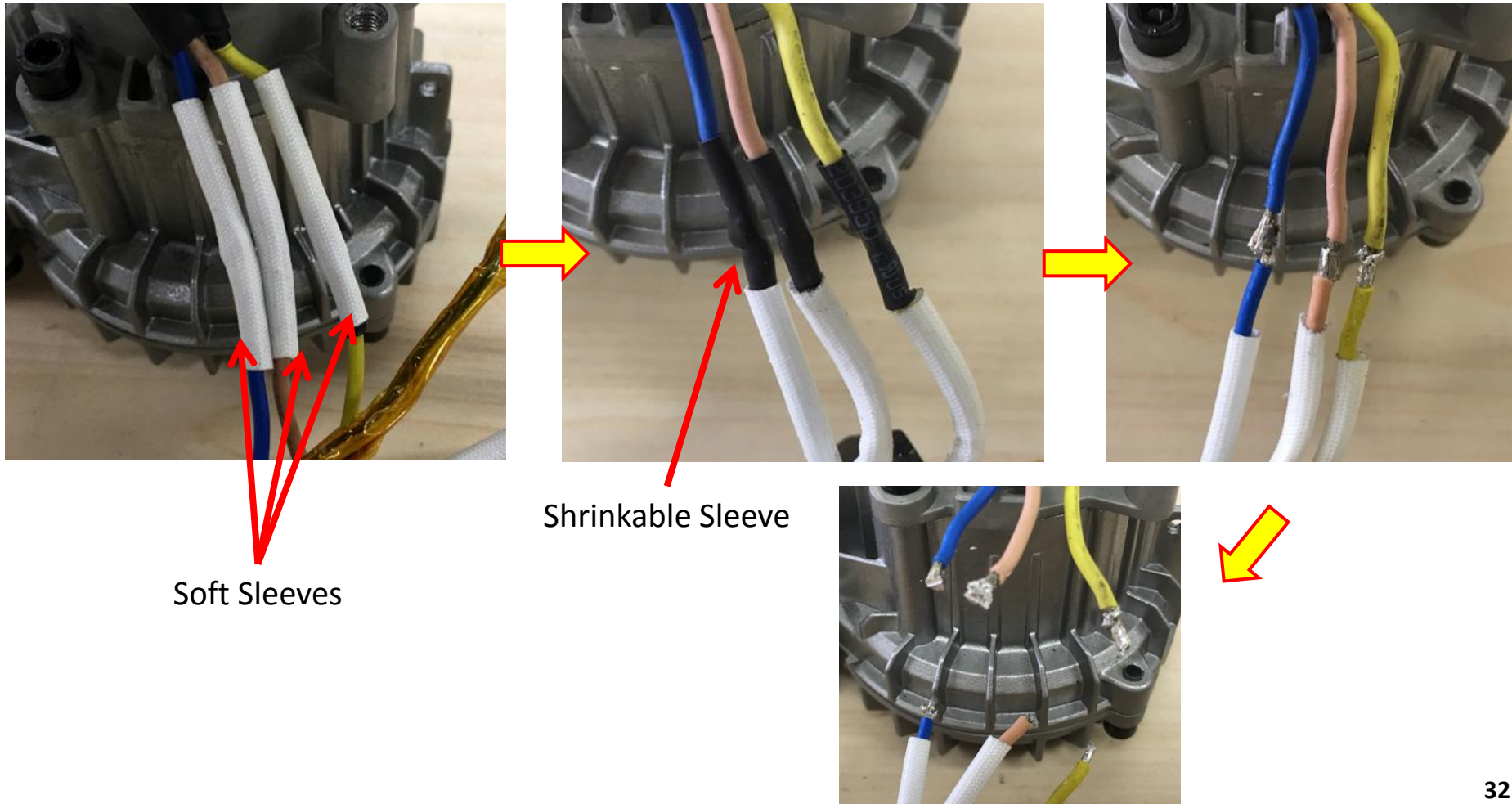

Replacing the PCB Assembly

HT5100E/HT6500E Hedge Trimmer

11. Replace with a new PCBA if it is broken.
12. Mount the soft sleeves first, then mount the heat-shrinkable sleeves and solder the 3 joints with the 3 terminals on the motor, making sure the colors match.
13. Move the heat the shrinkable sleeves back and heat them with the hot air gun. Cover the heat-shrinkable sleeves with the soft sleeves..

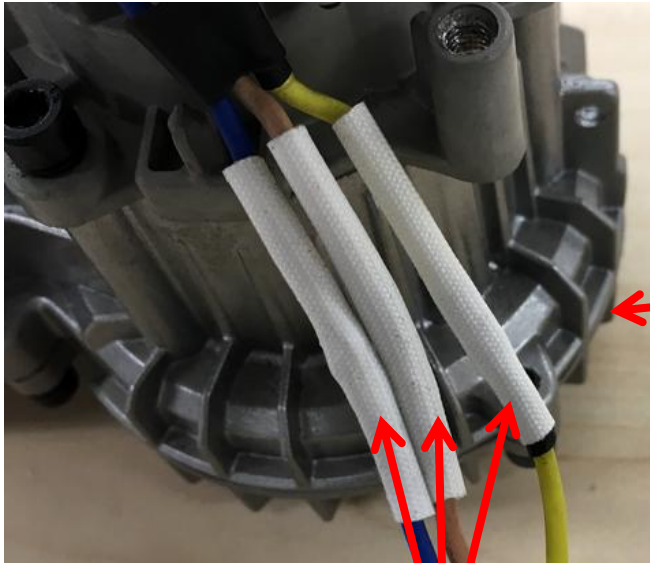

Three Terminals

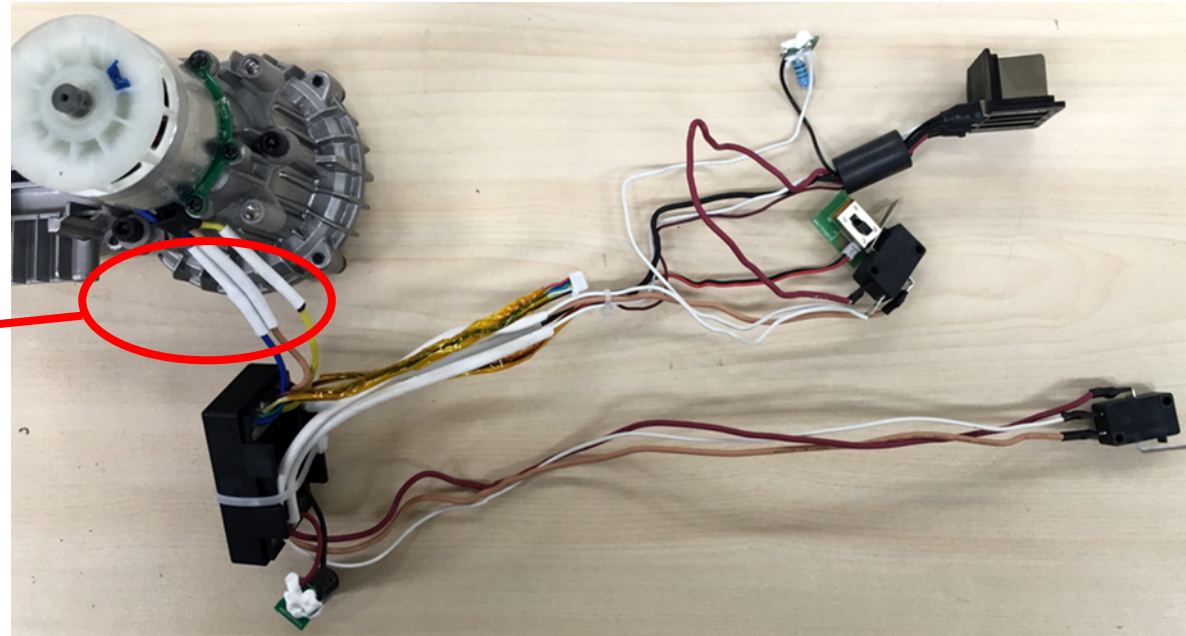

Replacing the PCB Assembly

13. Place the new PCBA in gear box assembly as shown in figure 2.

14. Insert the plug into the outlet softly and add the silicone sealant as shown in figure 3.

Fig.2

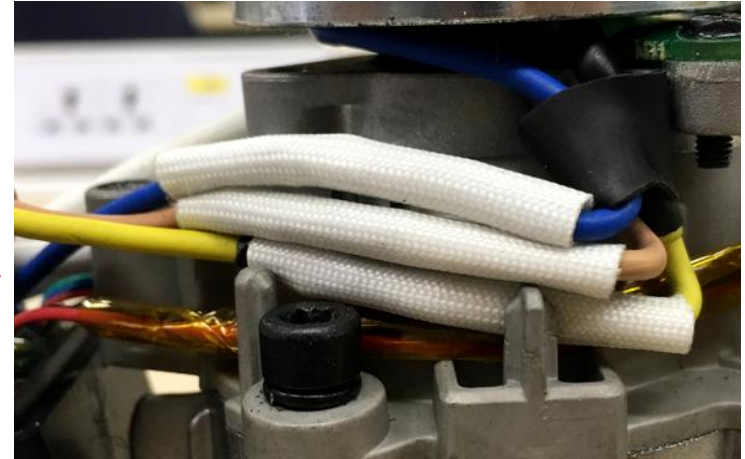
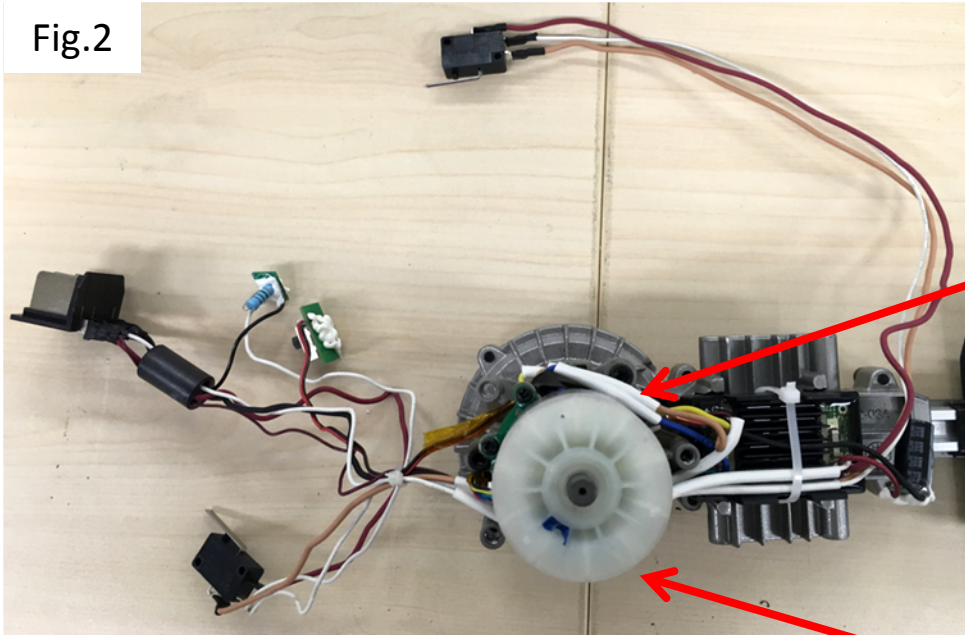
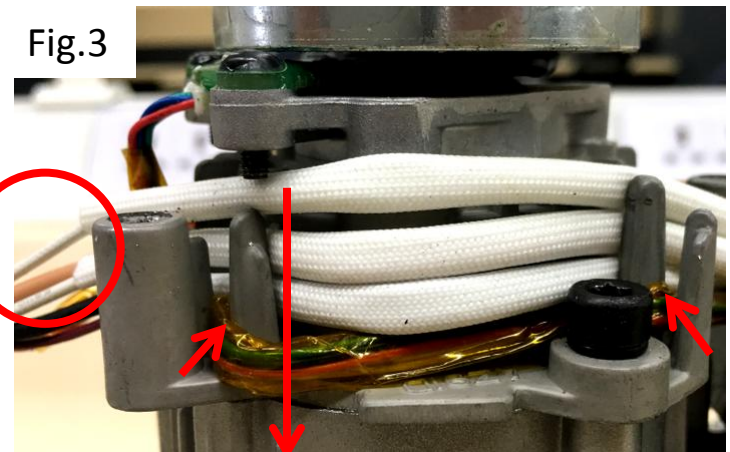

Fig.3



White ←
White and Brown ←
Black and Red ←

Notice the Location of This Wire.

Replacing the PCB Assembly

HT5100E/HT6500E Hedge Trimmer

15. Mount the top motor cover with 3 thread forming screws with loctite and a torque of 1.4~1.6Nm.
16. Mount the left rear handle and left housing as well as the damping ring.

NOTICE: Do not forget to mount the damping ring during this step.

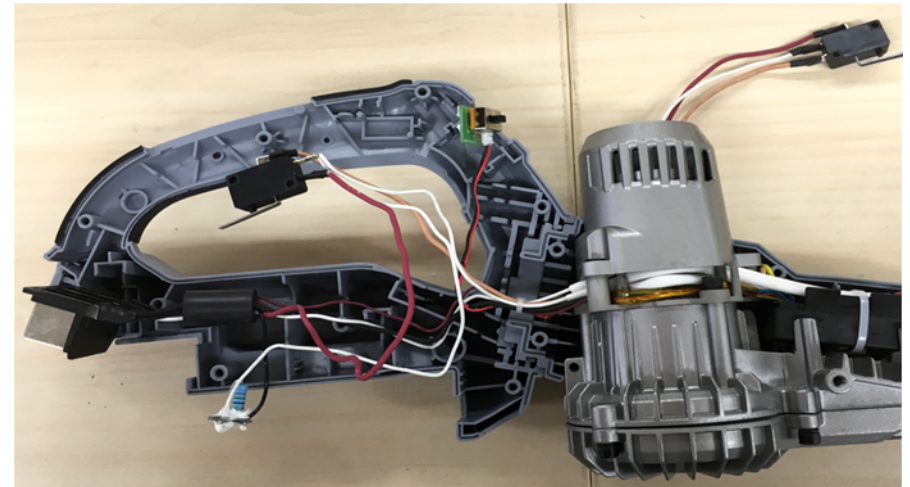
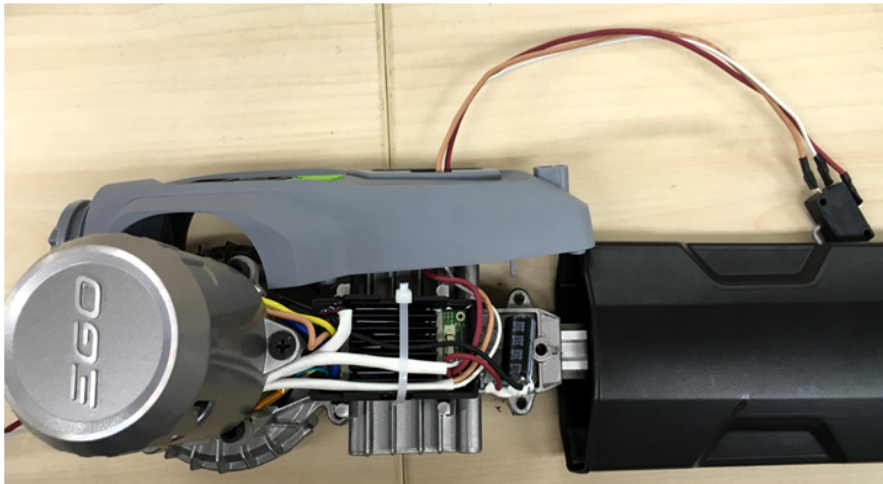

Description	Part Number	Qty
Thread Forming Screw	5610086004	3

Replacing the PCB Assembly

HT5100E/HT6500E Hedge Trimmer

17. Mount the speed adjustment knob, PCBA and add the silicone sealant.
18. Align the thin red wire 1# and thin black wires in the left rear handle housing.

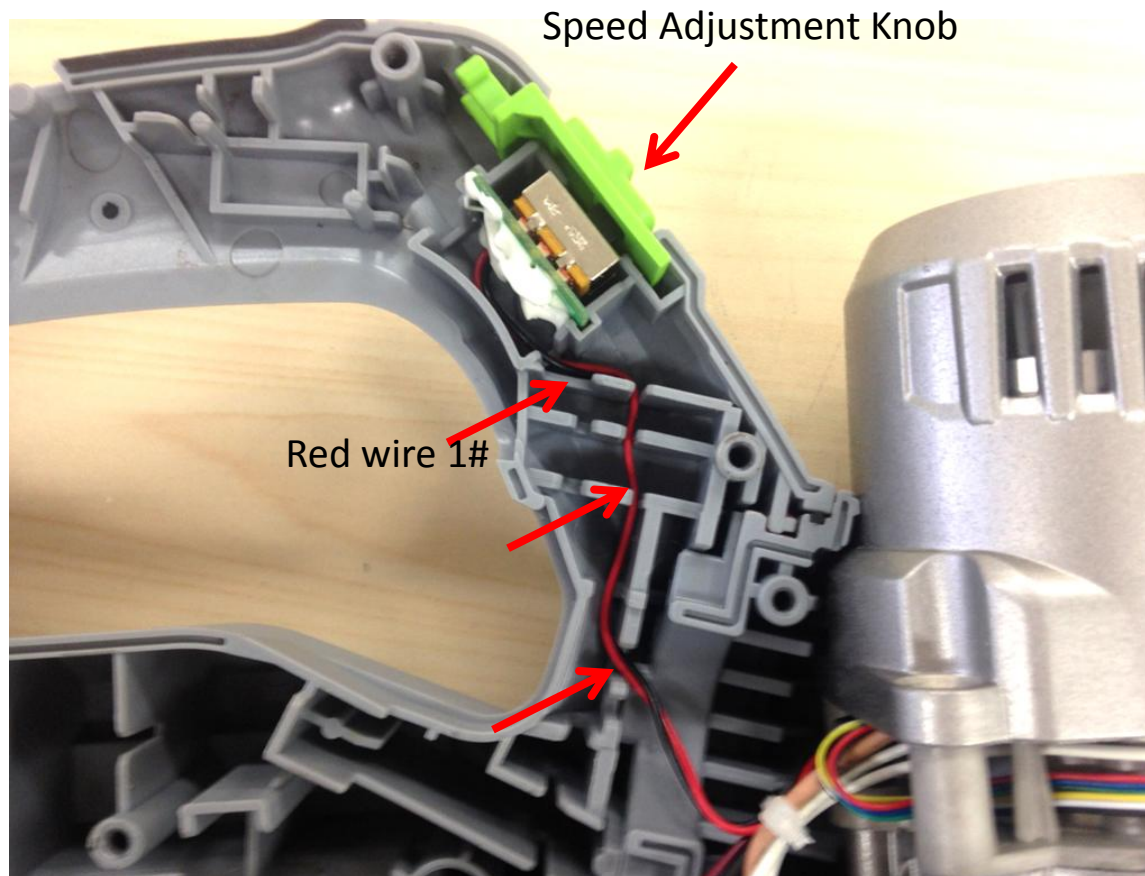

Replacing the PCB Assembly

HT5100E/HT6500E Hedge Trimmer

19. Mount the rear switch and align the two white wires, brown and red wire.

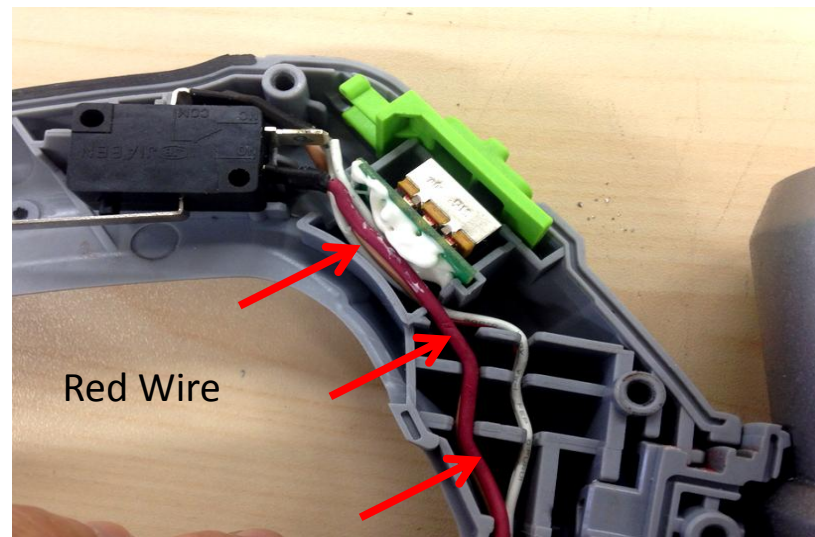
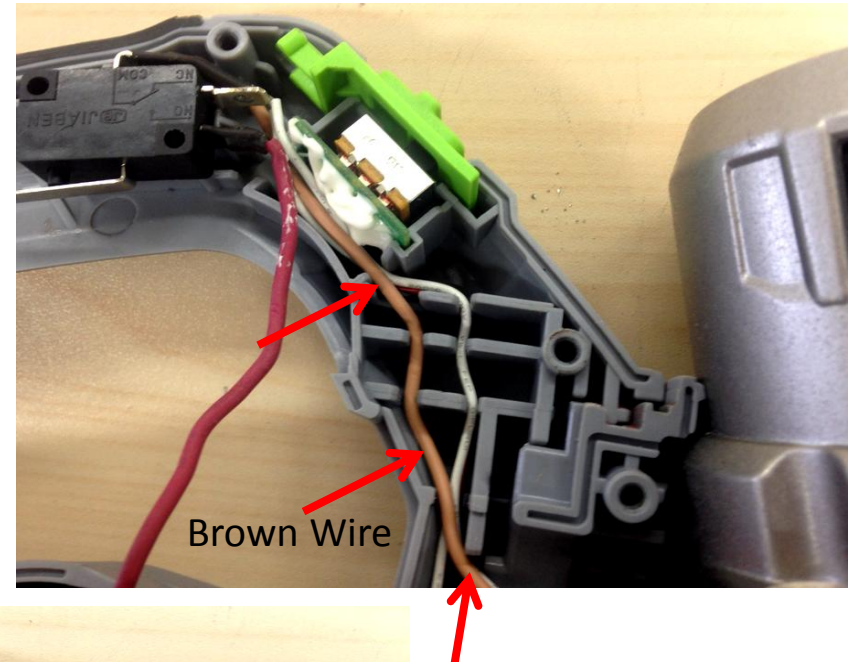
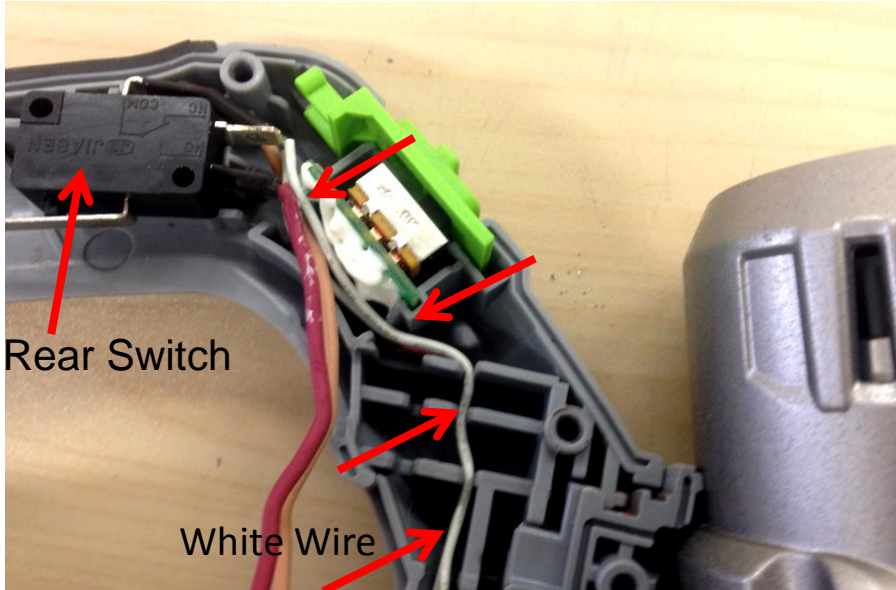

Replacing the PCB Assembly

HT5100E/HT6500E Hedge Trimmer

20. Mount the PCBA, align the thin red wire 2#, white and thick black wire in turn. Add silicone sealant to the PCBA as the figure shows below.

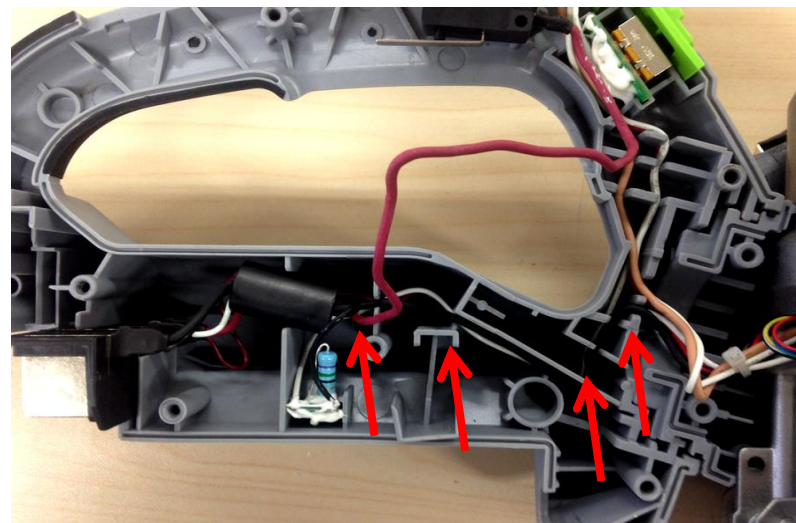
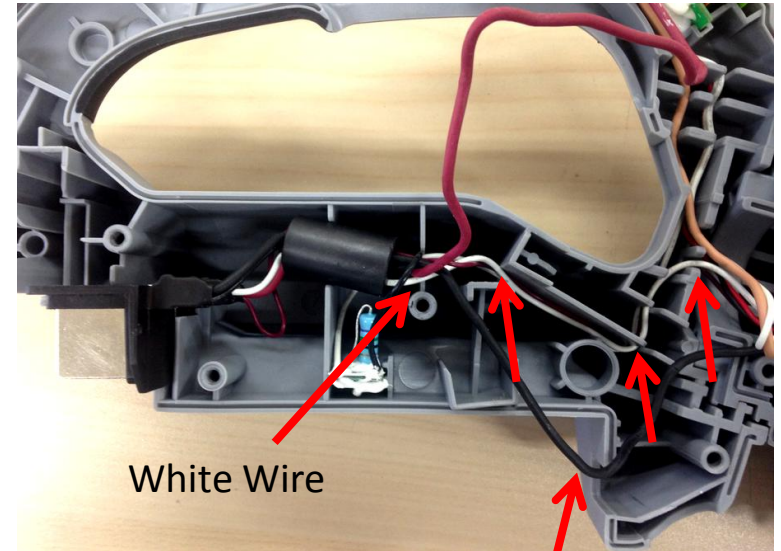
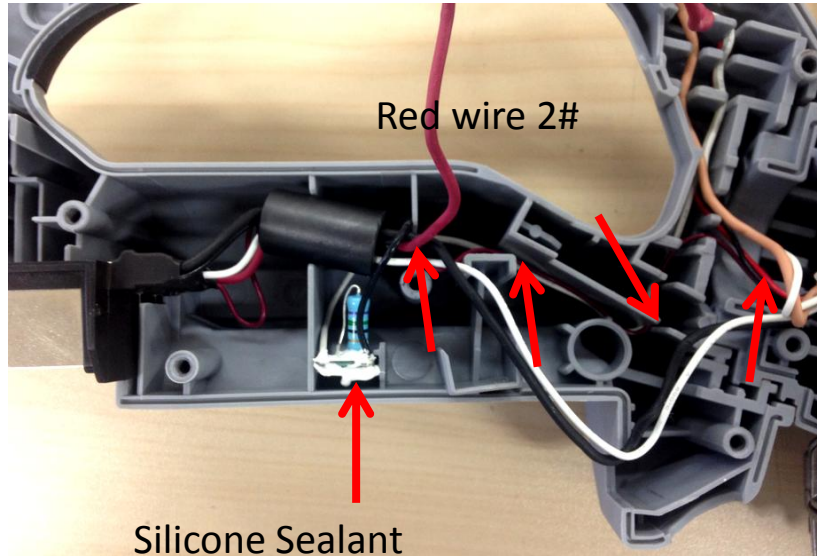

Replacing the PCB Assembly

HT5100E/HT6500E Hedge Trimmer

21. Align the thick red wire above the thick black wire.

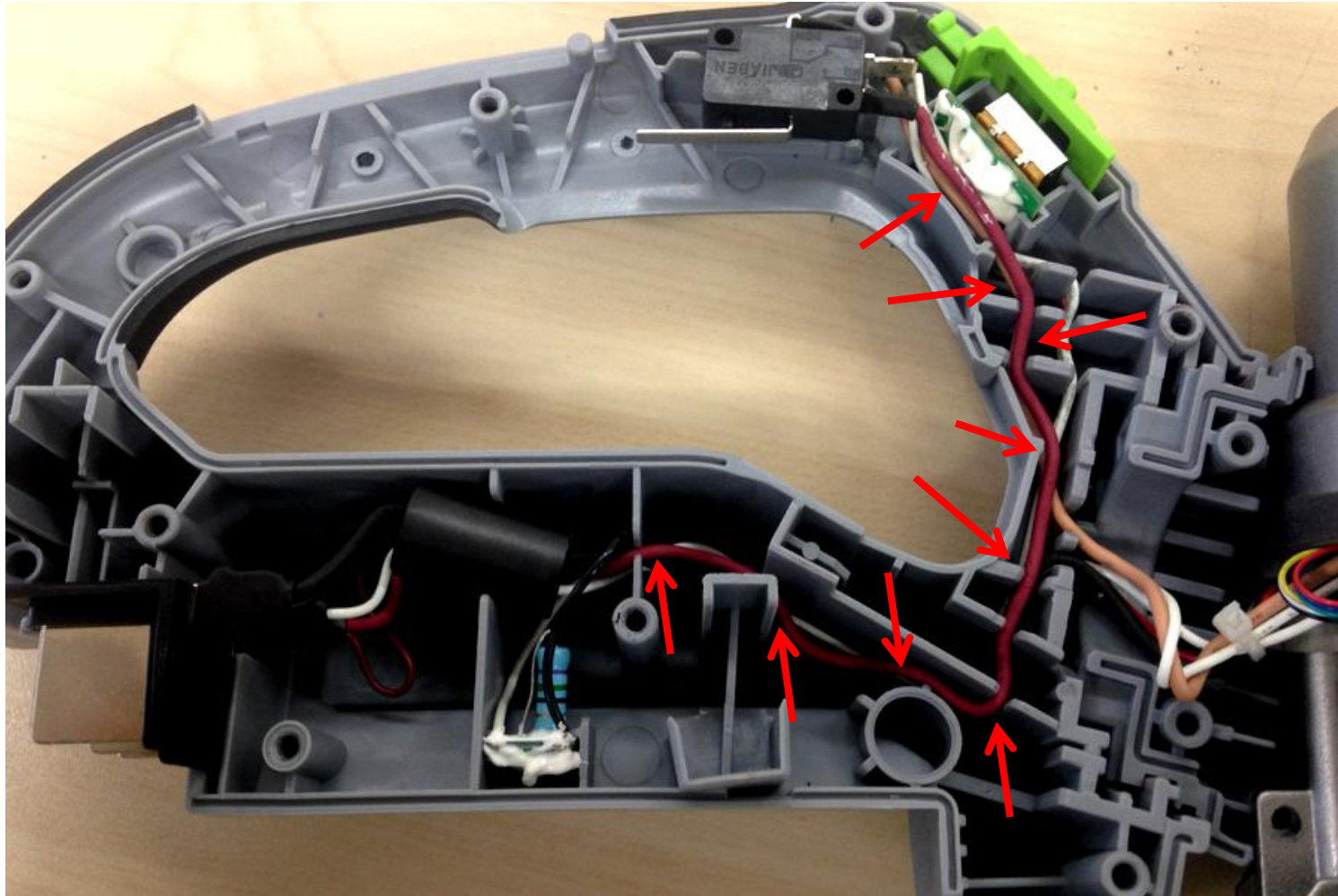

Replacing the PCB Assembly

HT5100E/HT6500E Hedge Trimmer

22. Mount the lock lever, ejection lever, lock-off trigger, rear switch trigger, battery release button, latch in the left rear handle.

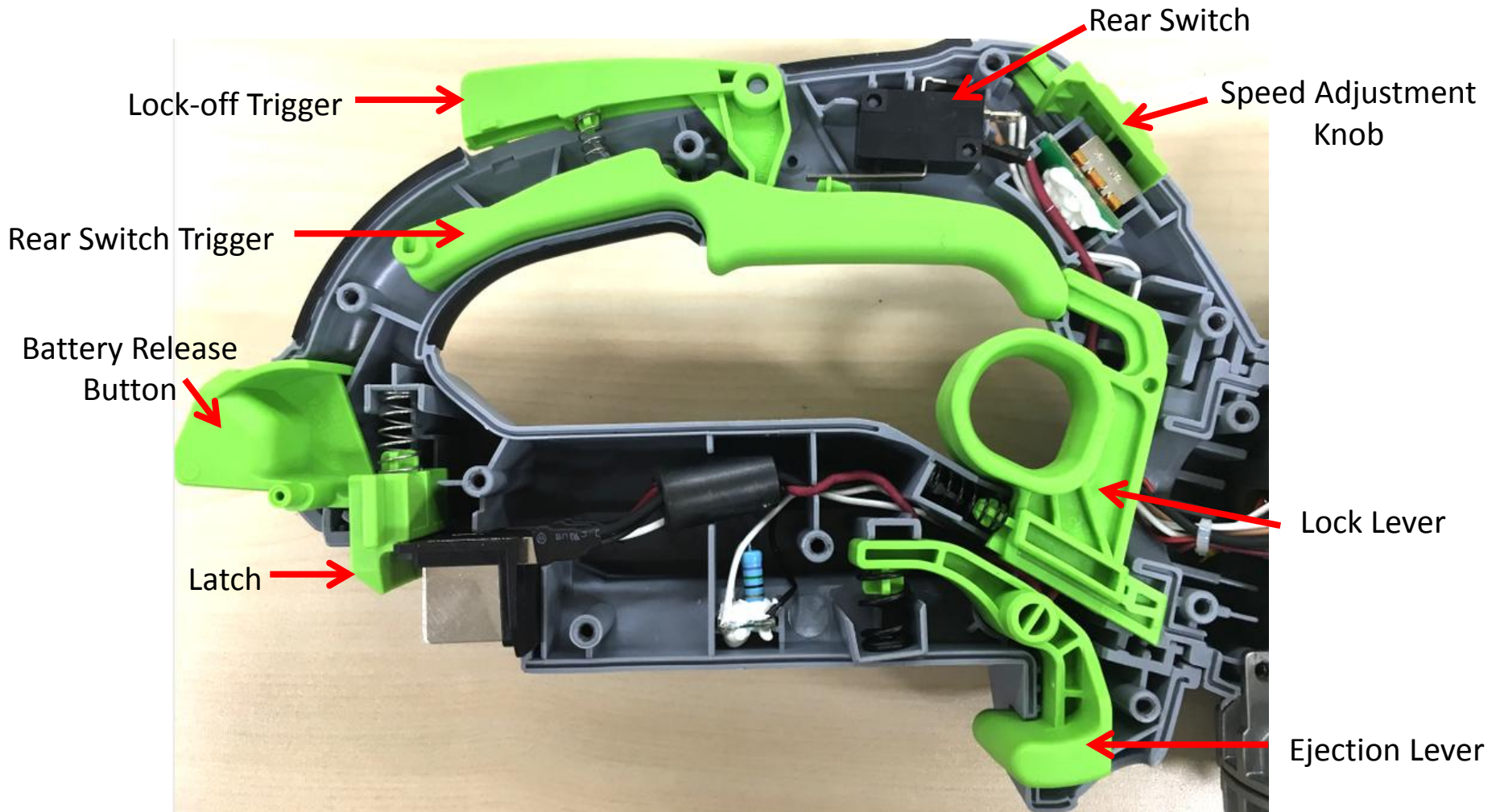

Replacing the PCB Assembly

HT5100E/HT6500E Hedge Trimmer

23. Mount the right rear handle and right housing, tighten the 13 tapping screws with a torque of 1.1~1.3Nm.
24. Following “**Replacing the Front Handle Set**” to assemble the front handle and guard.



Description	Part Number	Qty
Tapping Screw	5610032004	13

Part 4: Replacing the Motor and Gear Box Assembly

Replacing the Motor and Gear Box ASSY.

HT5100E/HT6500E Hedge Trimmer

1. Following the instructions for “**Replacing the Front handle Set**” to remove the guard, front handle set.
2. Following the instruction for “**Replacing the PCB Assembly**” to separate the PCBA from the motor.
3. Following the instructions for “**Replacing the Blade Assembly**” to separate the blade assembly.



Replacing the Motor and Gear Box ASSY.

HT5100E/HT6500E Hedge Trimmer

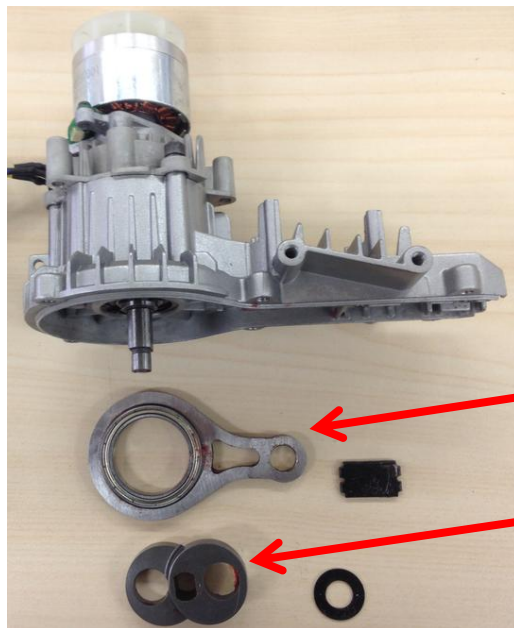
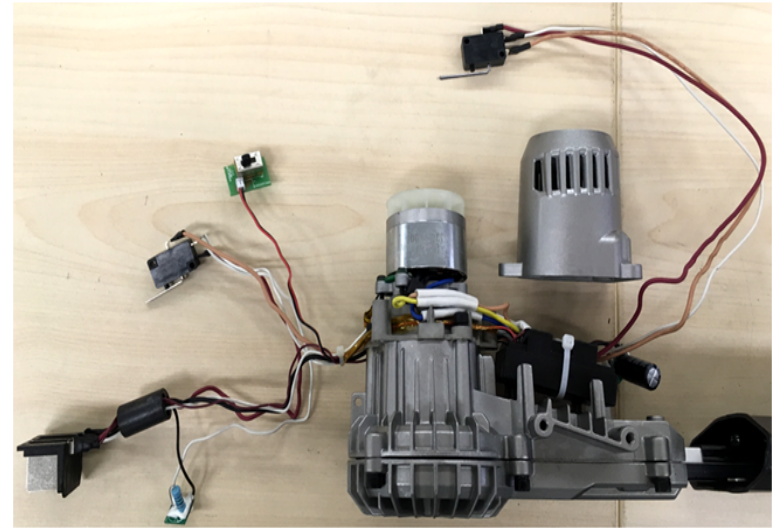

Link Assembly

Eccentric Block

Replacing the Motor and Gear Box ASSY.

HT5100E/HT6500E Hedge Trimmer

4. Use a 5mm hex wrench to remove the 3 hexagon socket screws from the gear box cover and remove the gear box assembly.
5. Remove the 3 hexagon screws inside the gear box cover to separate the motor from the gear box cover. Replace the motor or the gear box cover if broken.

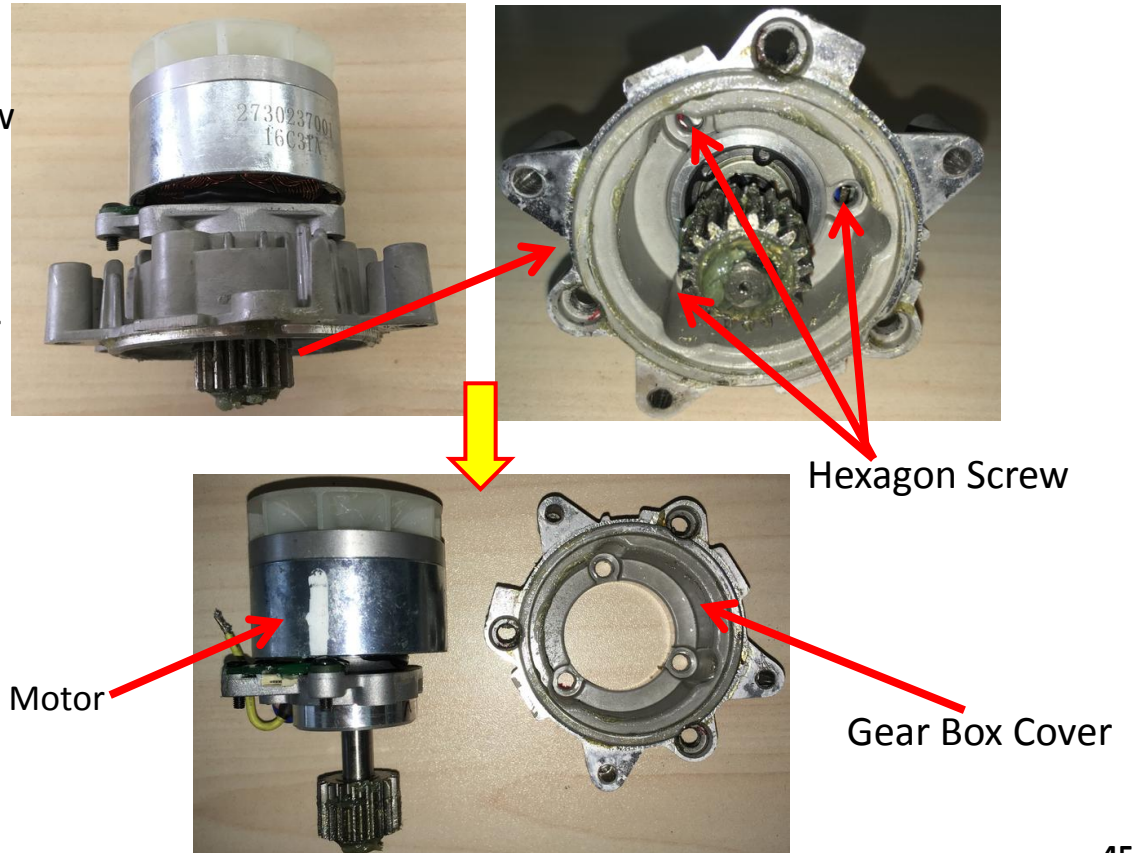
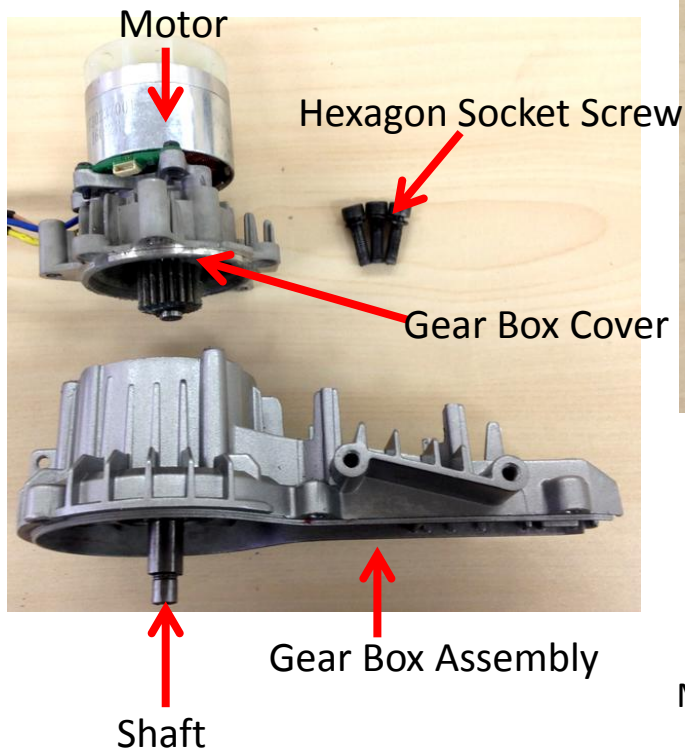

Replacing the Motor and Gear Box ASSY.

HT5100E/HT6500E Hedge Trimmer

Description	Part Number	Qty
Hexagon Socket Screw	5620446003	3
Hexagon Lobular Screw	5620424002	3
Gear Box Cover	3421741001	1
Motor & Gear Assembly	2824568001	1

Replacing the Motor and Gear Box ASSY.

HT5100E/HT6500E Hedge Trimmer

6. Mount the motor into the gear box cover by tightening the 3 hexagon screws inside the gear box cover.
7. Mount the motor and cover set onto the gear box assembly by tightening the 3 new hexagon socket screws with the loctite, the torque is 4~4.5Nm.

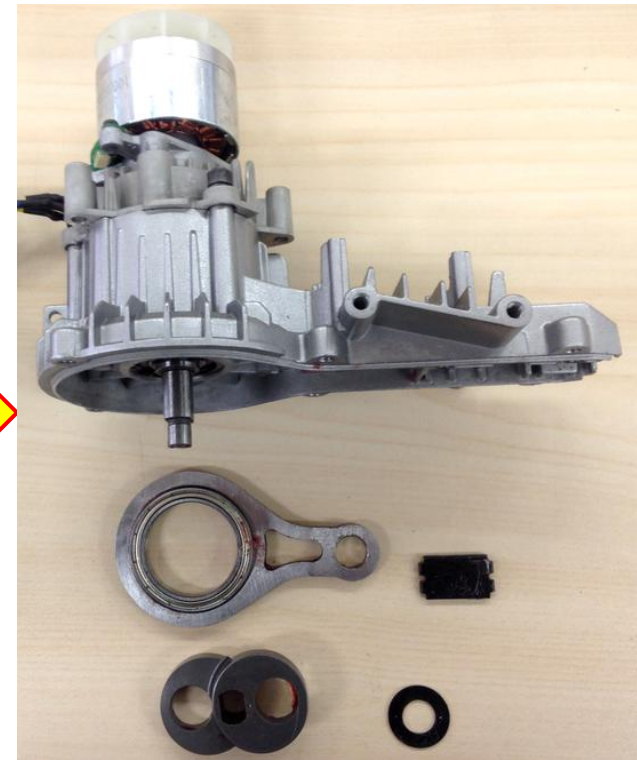
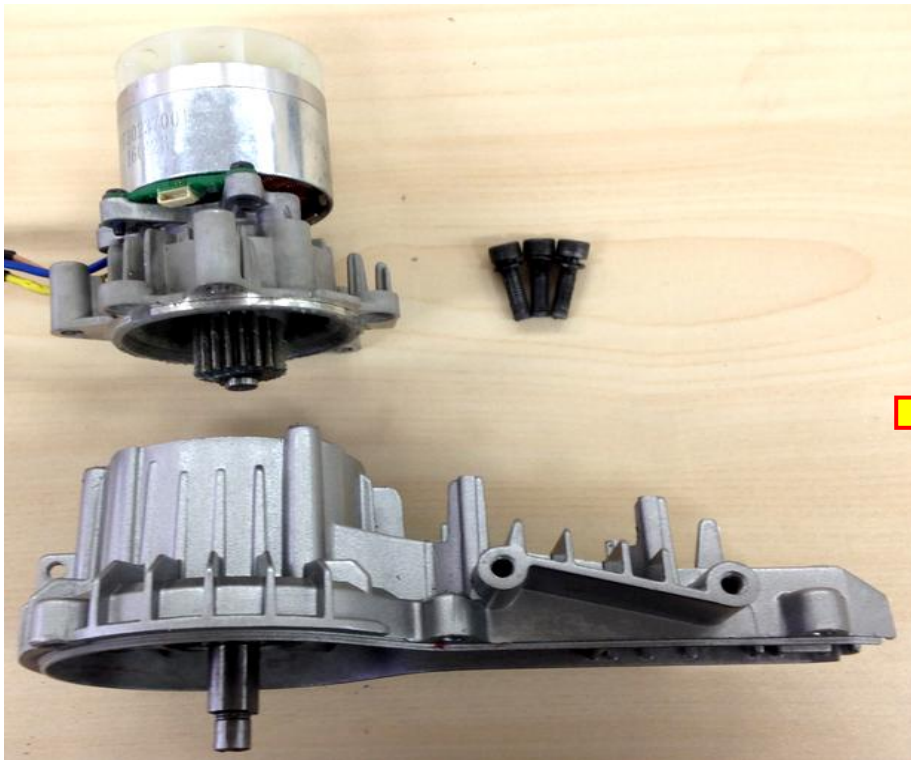

Replacing the Motor and Gear Box ASSY.

HT5100E/HT6500E Hedge Trimmer

8. Following the instructions for “**Replacing the PCB Assembly**” to connect the main PCBA to the motor and following the instructions for “**Replacing the Blade Assembly**” to mount the blade assembly onto the gear shaft.
9. Following the instructions for “**Replacing the PCBA Assembly**” to mount the left and right housing, the rear handle and motor top cover .

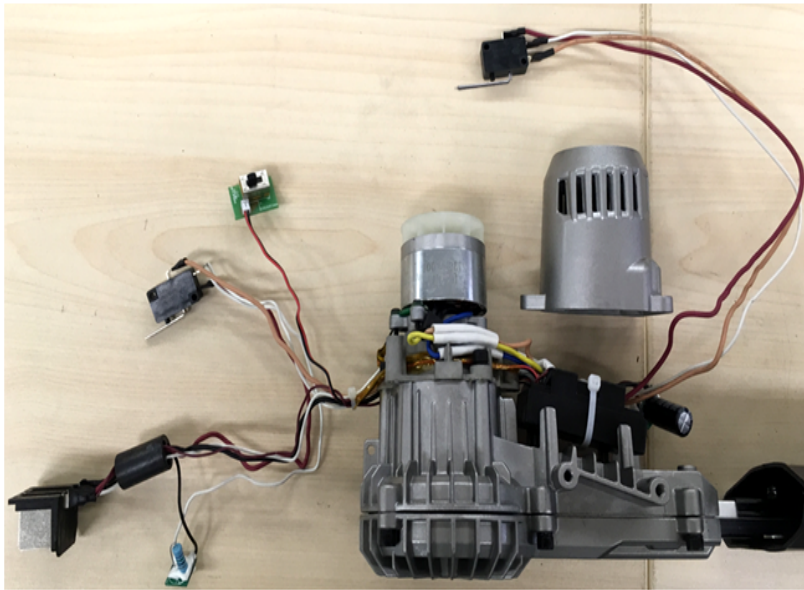

Replacing the Motor and Gear Box ASSY.

HT5100E/HT6500E Hedge Trimmer

10. Following the instructions for “Replacing the Front Handle Set” to mount the front handle and guard.



Part 5: Repairs to the Gear Box

Repairs to the Gear Box

HT5100E/HT6500E Hedge Trimmer

1. Following the instructions for “**Replacing The Motor and Gear Box Assembly**” to separate the motor and gear box assembly from the PCBA.
2. Loosen the 3 hexagon socket screws on the gear box cover to separate the gear box assembly from the gear box cover and motor set.

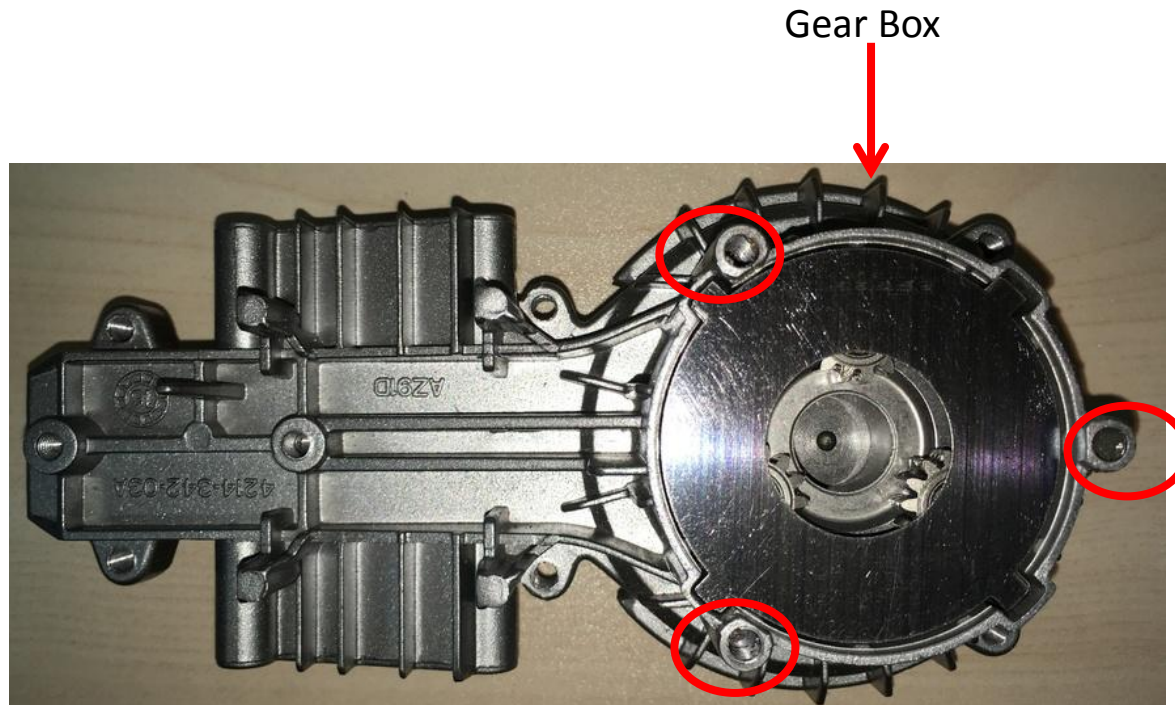

Repairs to the Gear Box

HT5100E/HT6500E Hedge Trimmer

3. Remove the parts in the gear box in turn.

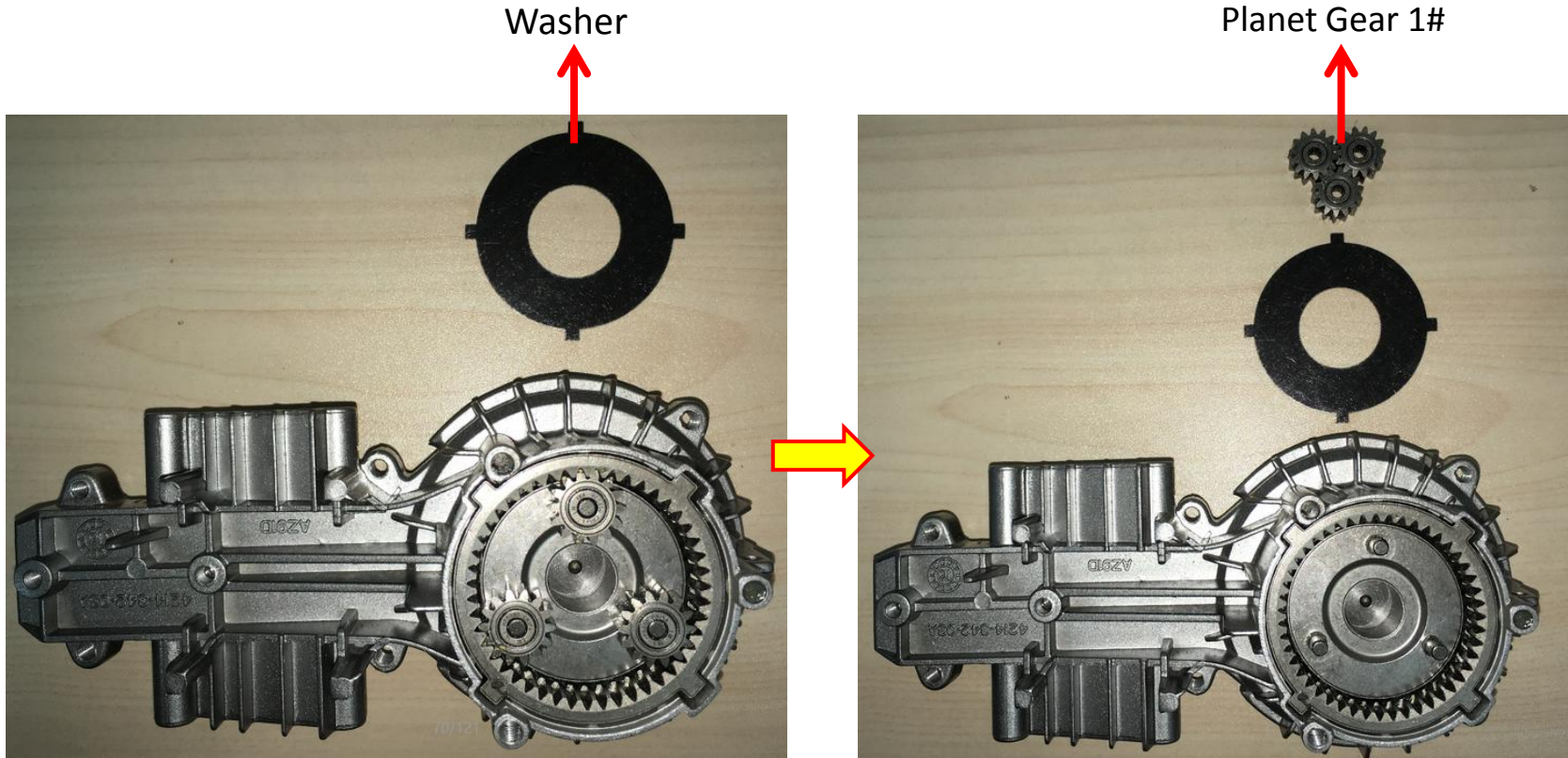

Repairs to the Gear Box

HT5100E/HT6500E Hedge Trimmer

Ring Gear 1#

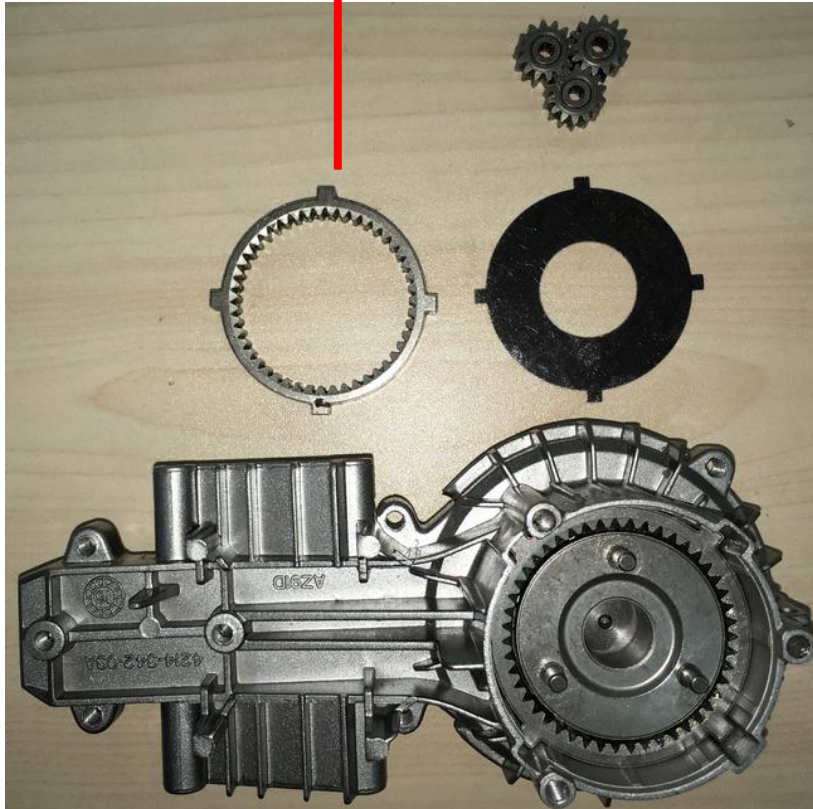

Sun Gear



Repairs to the Gear Box

HT5100E/HT6500E Hedge Trimmer

4. Replace the parts if they appear worn or damaged.

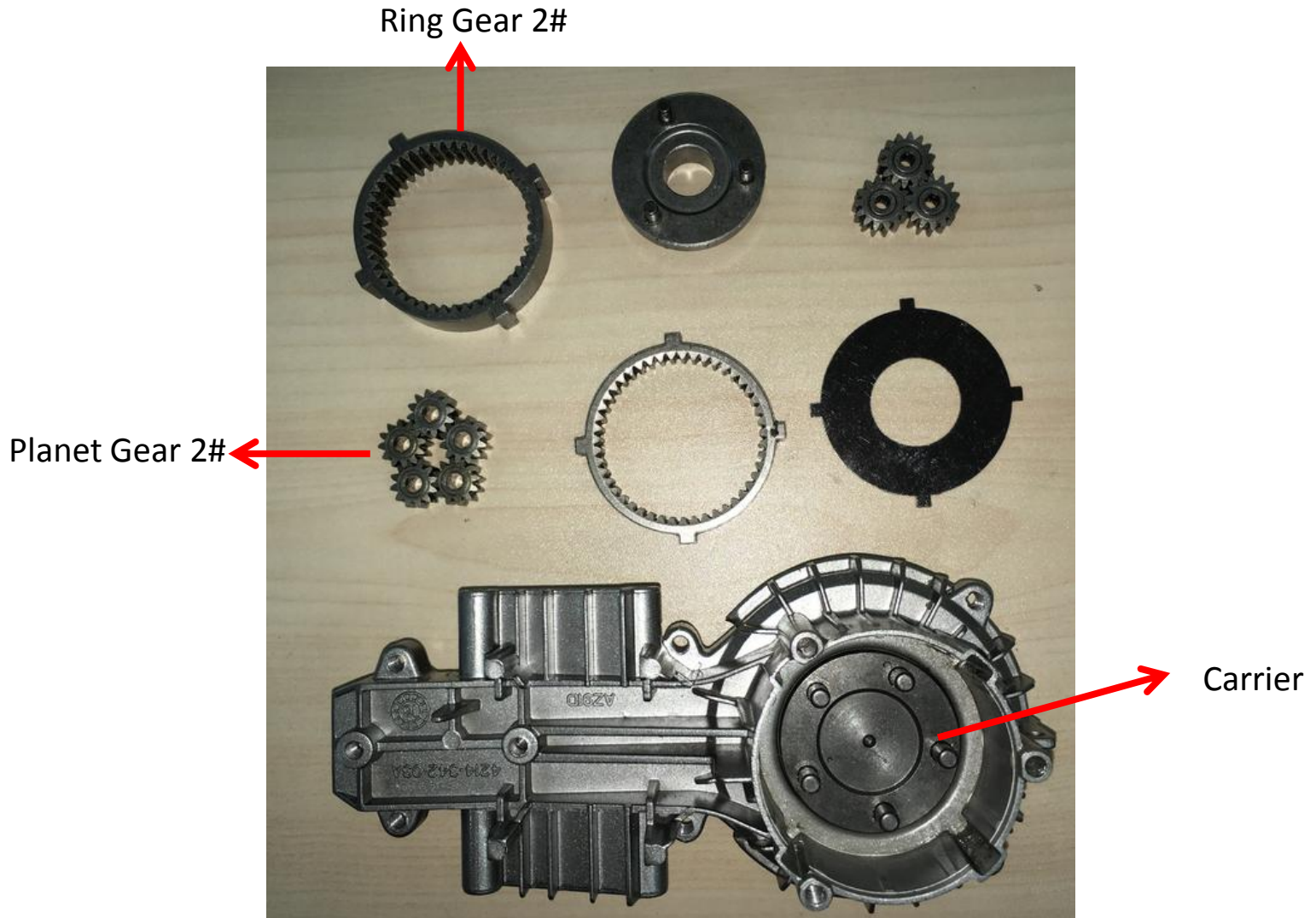

Repairs to the Gear Box

HT5100E/HT6500E Hedge Trimmer

Description	Part Number	Qty
Motor & Gear Assembly	2824568001	1
Washer	5650529001	1
Ring Gear 1#	3520889001	1
Planet Gear 1#	2824554001	3
Sun Gear	2824336001	1
Planet Gear 2#	3520887001	5
Ring Gear 2#	3520888001	1
Carrier	2824387001	1

Repairs to the Gear Box

HT5100E/HT6500E Hedge Trimmer

5. Assemble gear box parts in turn.

(1) Align the rib of the ring gear 2# with the slot of the gear case, place the ring gear 2# into the gear case. Distinguish ring gear 1# and ring gear 2# by the different height size. Ring gear 2# is higher than ring gear 1#. Assemble the 5 planet gears into position and add about 6g grease (SYN-setral-PU 2) .

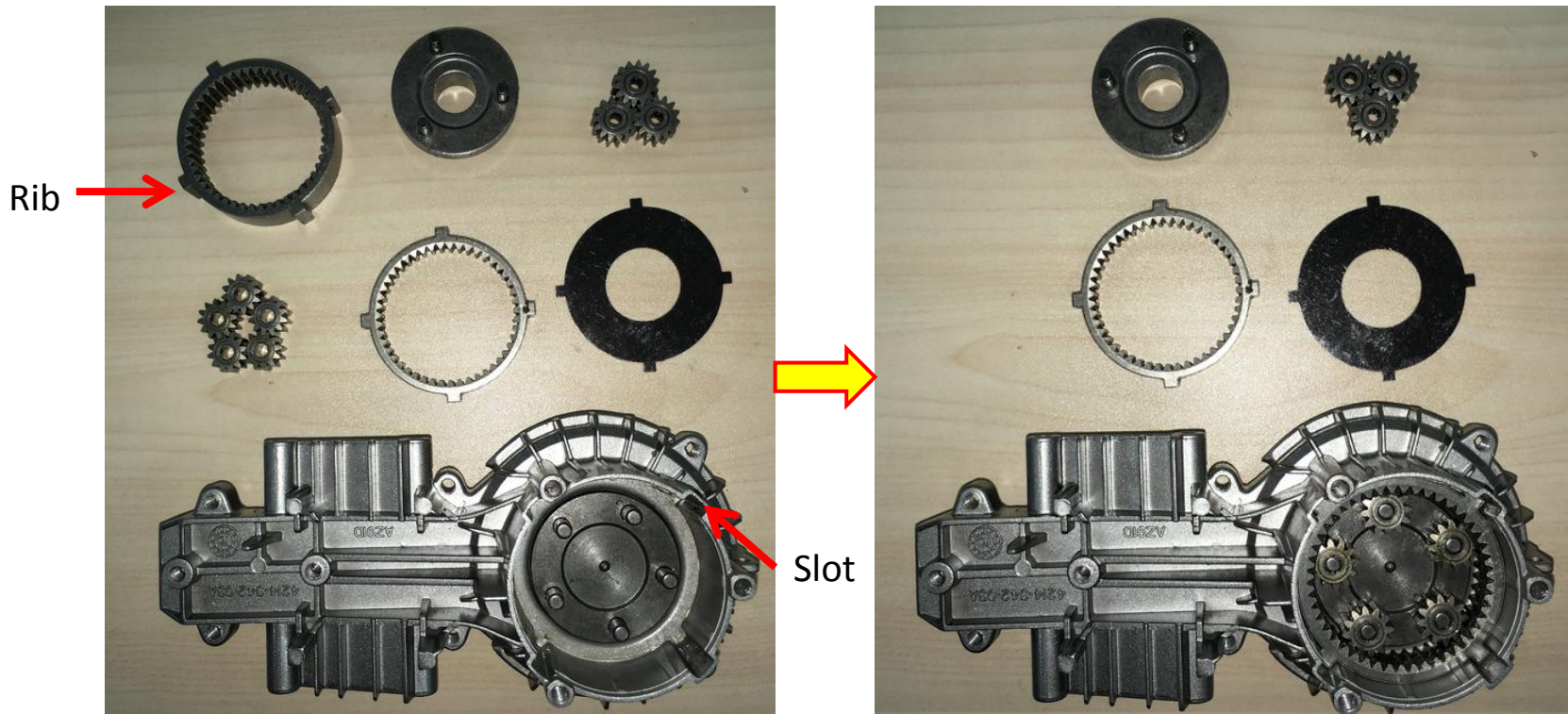

Repairs to the Gear Box

HT5100E/HT6500E Hedge Trimmer

(2) Insert the sun gear among the planet gears, making sure they are properly engaged.

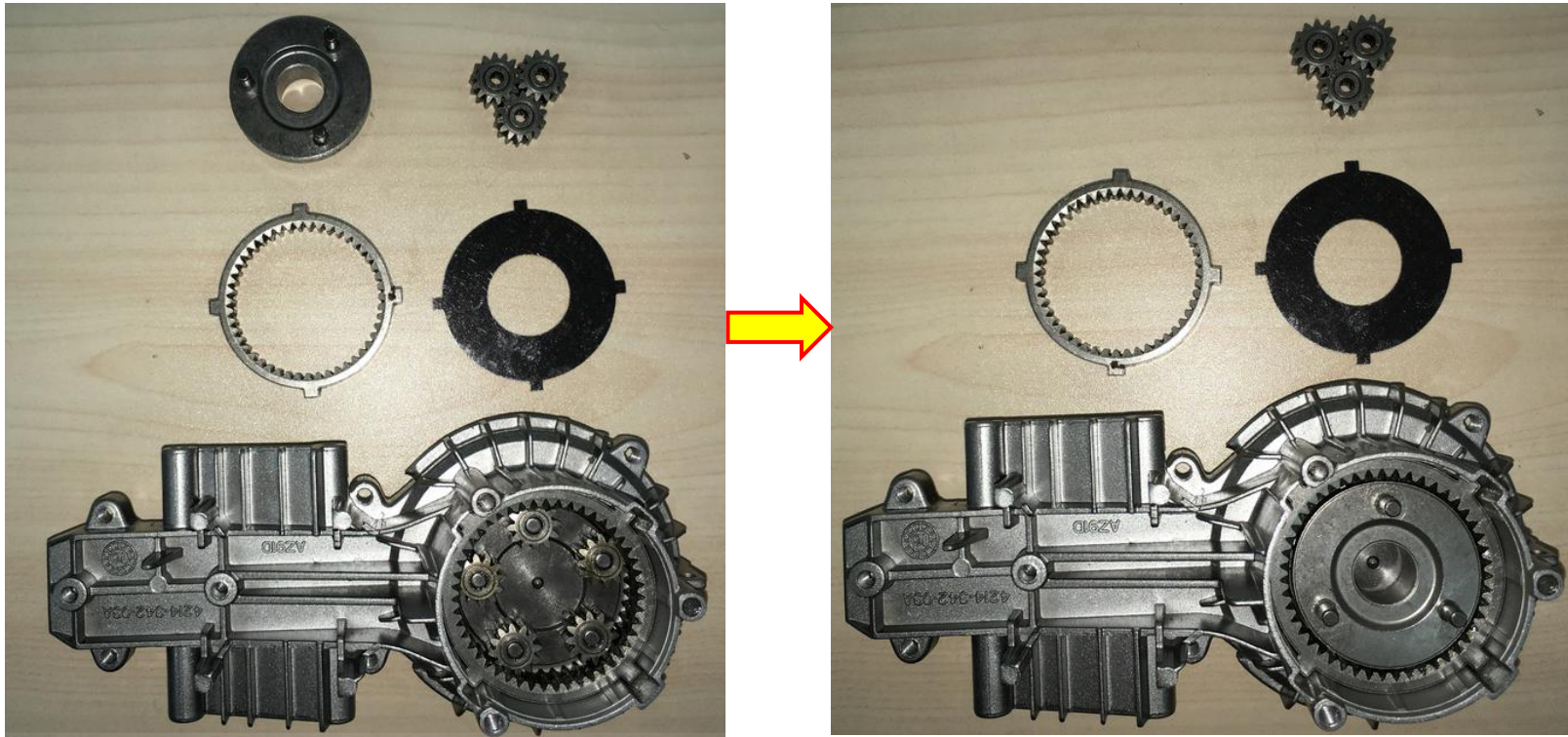

Repairs to the Gear Box

HT5100E/HT6500E Hedge Trimmer

- (3) Align the rib of the ring gear 1# with the slot of the gear case, place the planet gear 1# into the gear case and add about 6g grease (SYN-setral-PU 2).

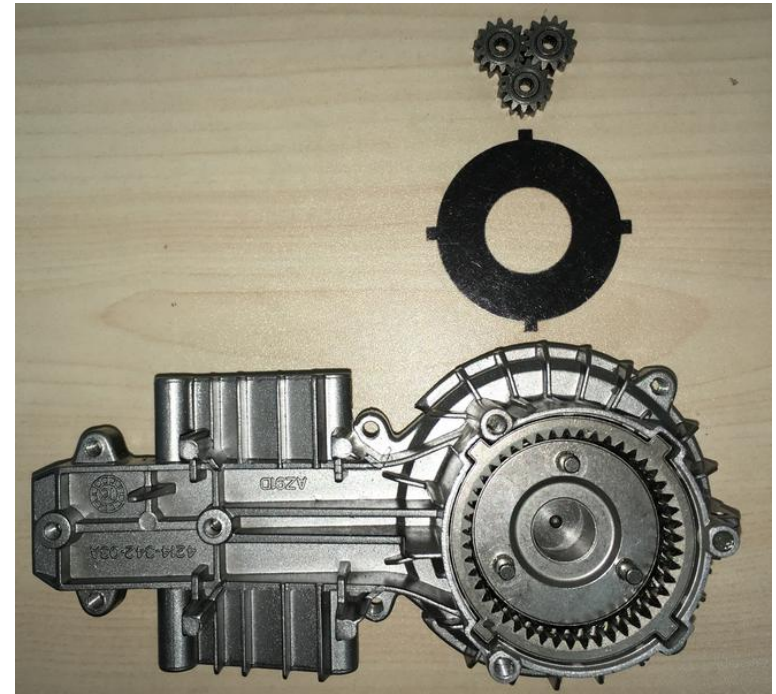
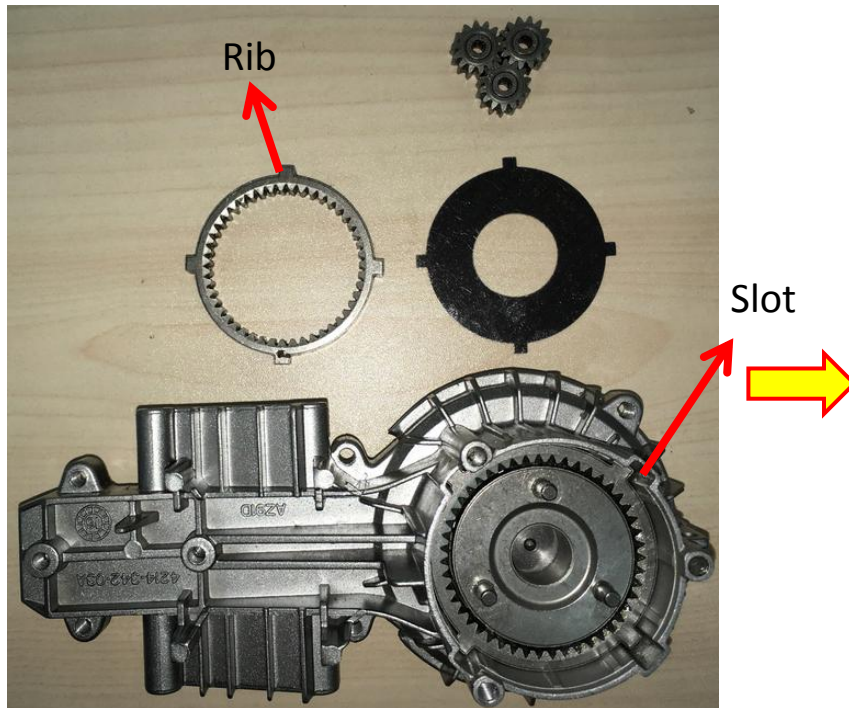

Repairs to the Gear Box

HT5100E/HT6500E Hedge Trimmer

- (4) Place the washer into the gear case.
- (5) Ensure that the surface of the washer is under the edge of the slot in the gear case. If not, reassemble all the parts from Step (1), making sure every step is correct.

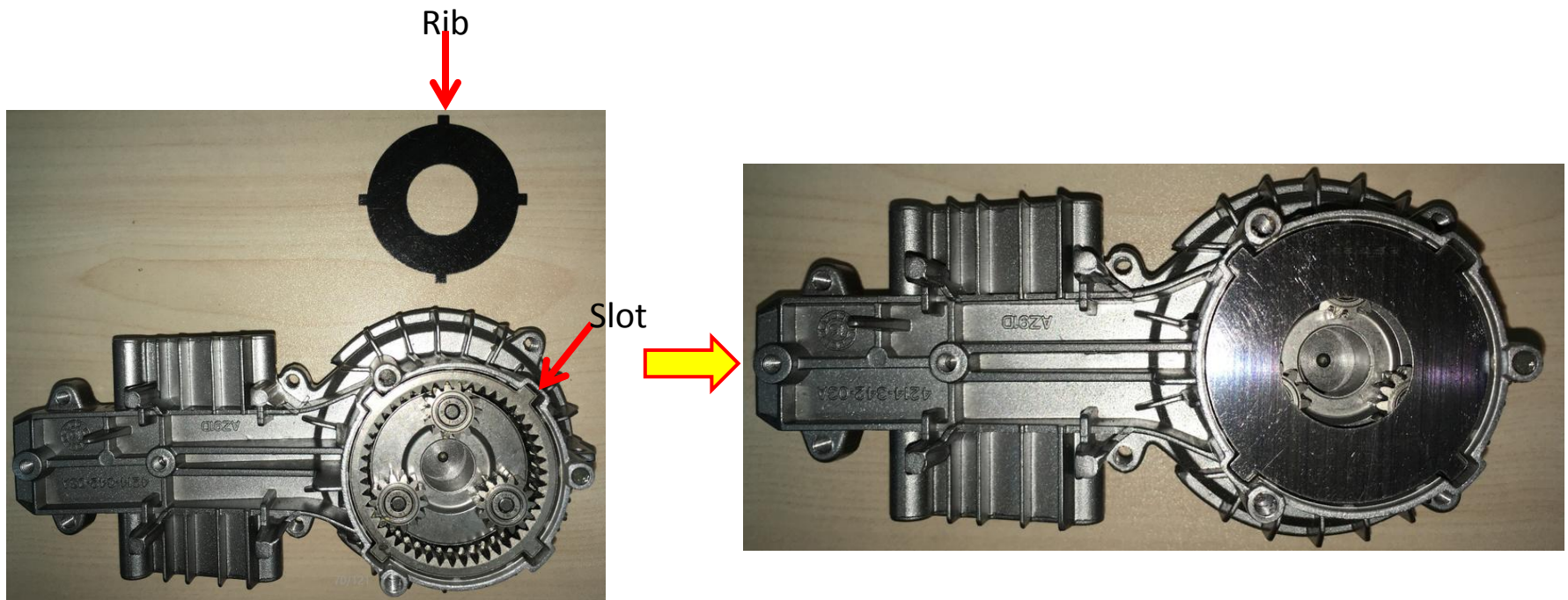

Repairs to the Gear Box

HT5100E/HT6500E Hedge Trimmer

6. Mount the gear box cover with the motor onto the gear box and fix it with 3 hexagon screws.

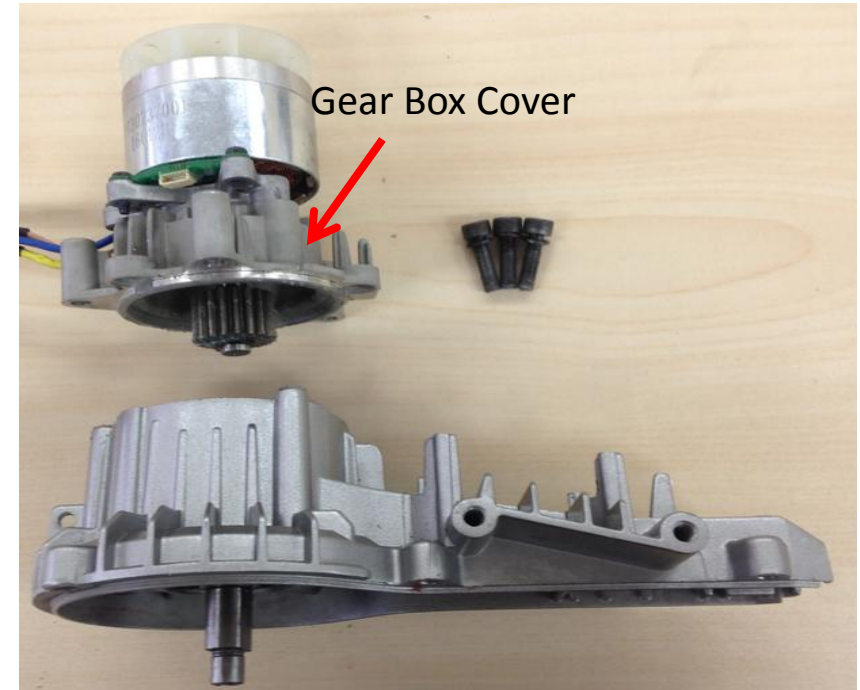
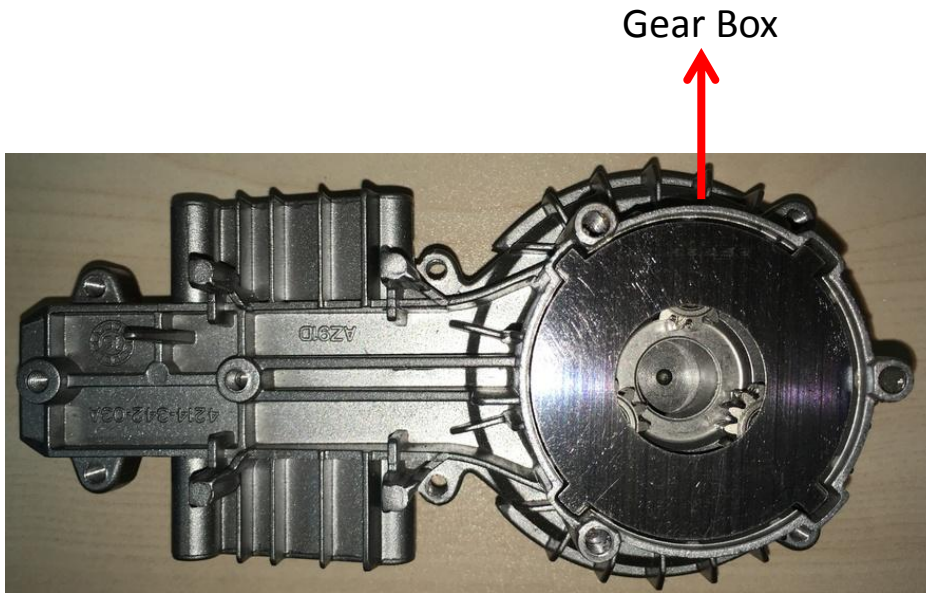

Repairs to the Gear Box

HT5100E/HT6500E Hedge Trimmer

7. Mount the gear box cover with 3 new hexagon screws. The torque is 1.4~1.6Nm, seal them with loctite.

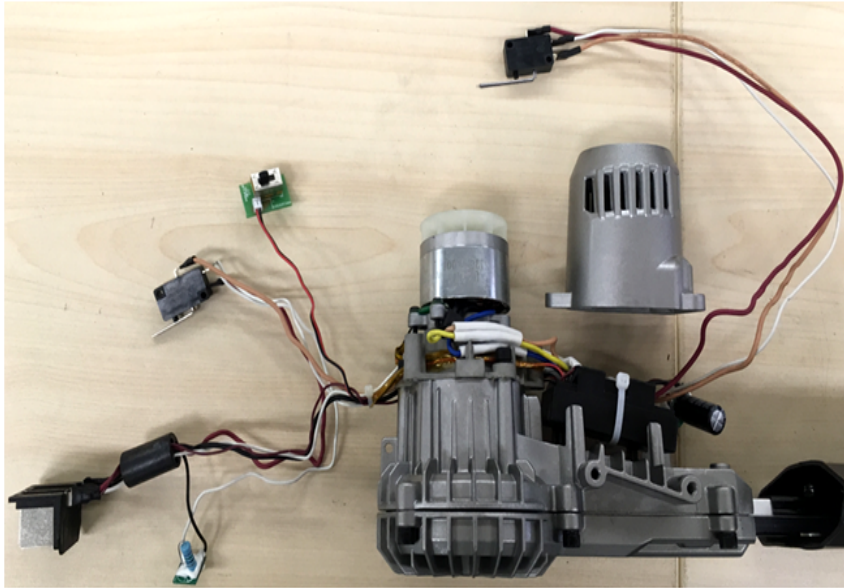

8. Follow the instructions for “**Replacing the PCB assembly**” to align the wires and close the housing.



THE END