

REPAIR GUIDELINE

PART 1: Blade Replacement - LM2010E Lawn Mower



Table of Contents

LM2010E Lawn Mower

NO.	Contents	Page
1	Blade Removal	3-5
2	Blade Installation	6-9

1. Blade Removal

1. Release switches and remove the battery pack from the mower.
2. While wearing protective gloves, turn the mower on its side (Fig. 1).
3. Place a metal rod (e.g., a thick bit) with a diameter less than 11mm into the fixing hole to act as a stabilizer and place another metal rod (e.g., a thin bit) with a diameter less than 6.35 mm into the holes (the through holes in the fan with the holes in the blade) to act as another stabilizer (Fig. 2).

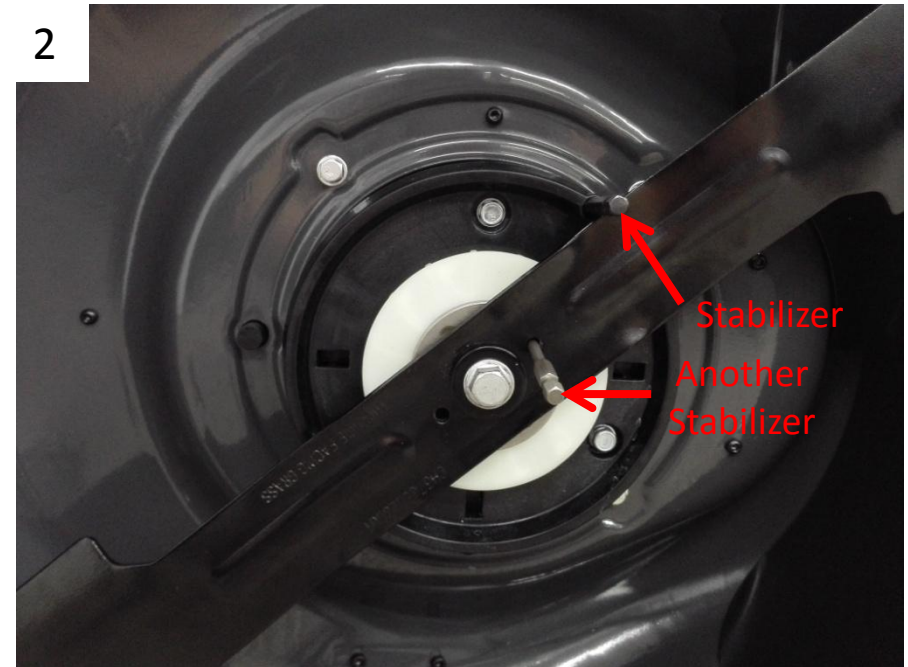
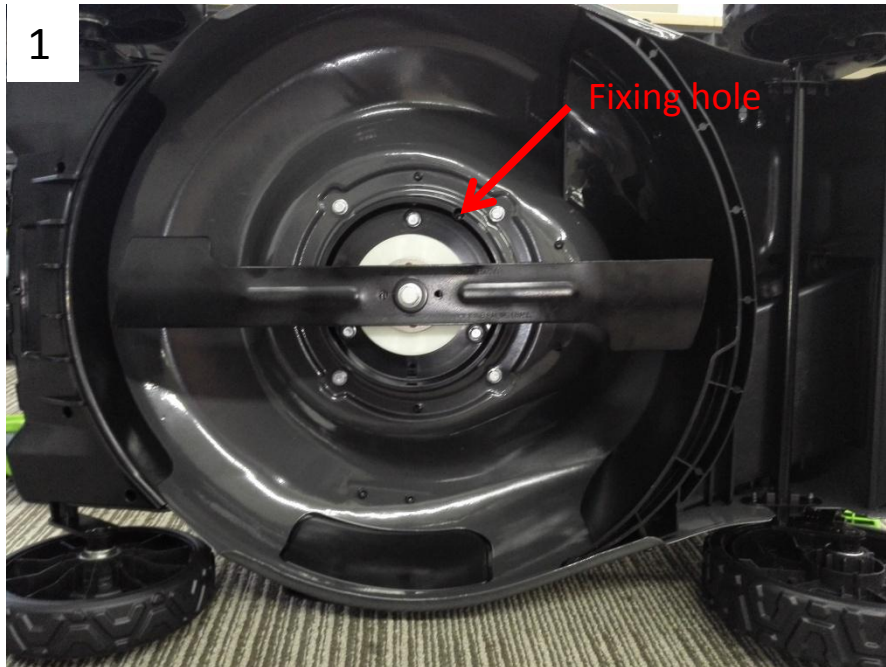

1. Blade Removal

4. Use a 14mm wrench to turn the blade bolt counterclockwise to loosen it.

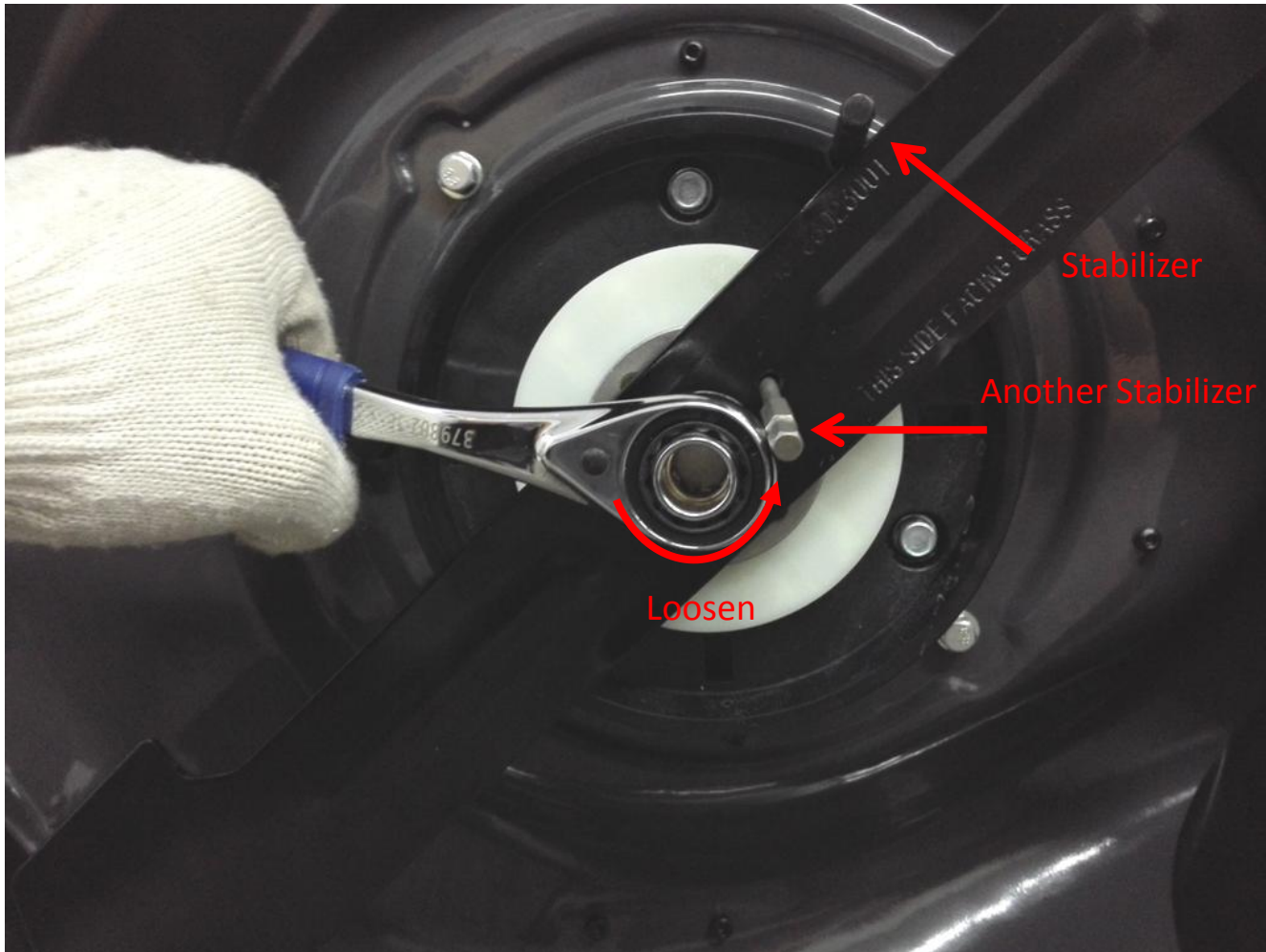

1. Blade Removal

5. Remove the bolt, outer flange and the blade. Replace any broken or worn parts.
6. Remove the inner flange and fan from the motor shaft, then replace any broken or worn parts.

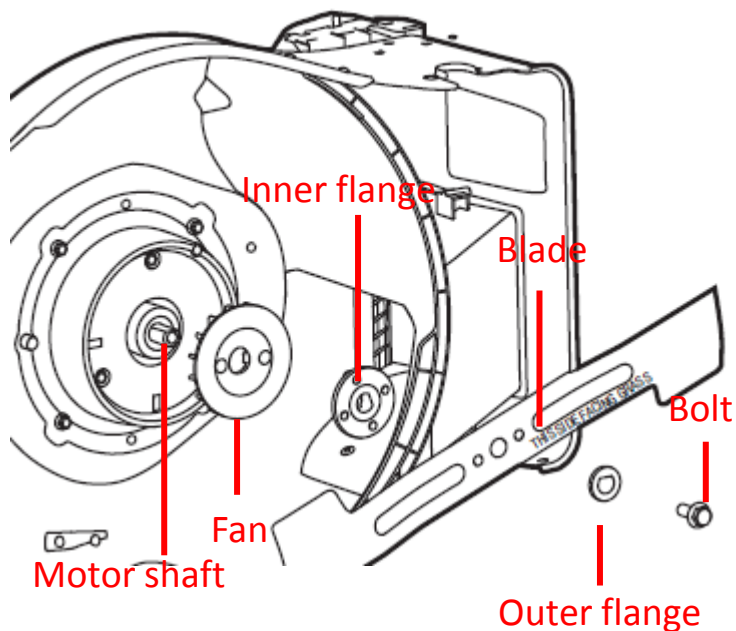

Description	Part Number	SPEC
Flange Bolt	5640226001	M10×25
Outer Flange	5650510001	---
Blade	3706023001	---
Inner Flange	3520852002	---
Fan	3127847001	---

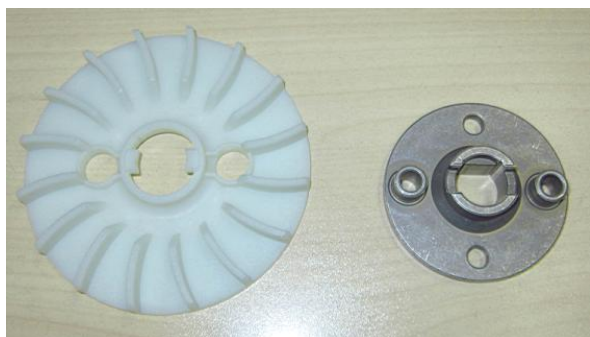

2. Blade Installation

1. Fix the inner flange into the fan.
2. Mount the fan and the inner flange onto the motor shaft with the fan blades towards the deck.

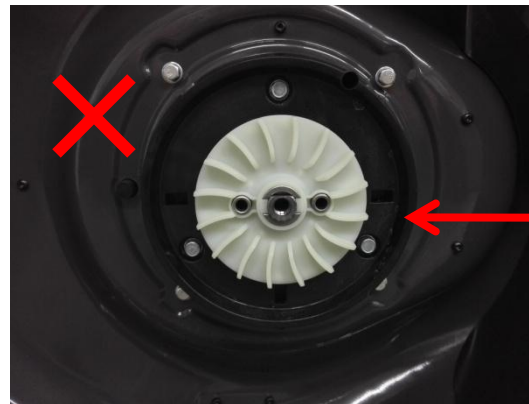
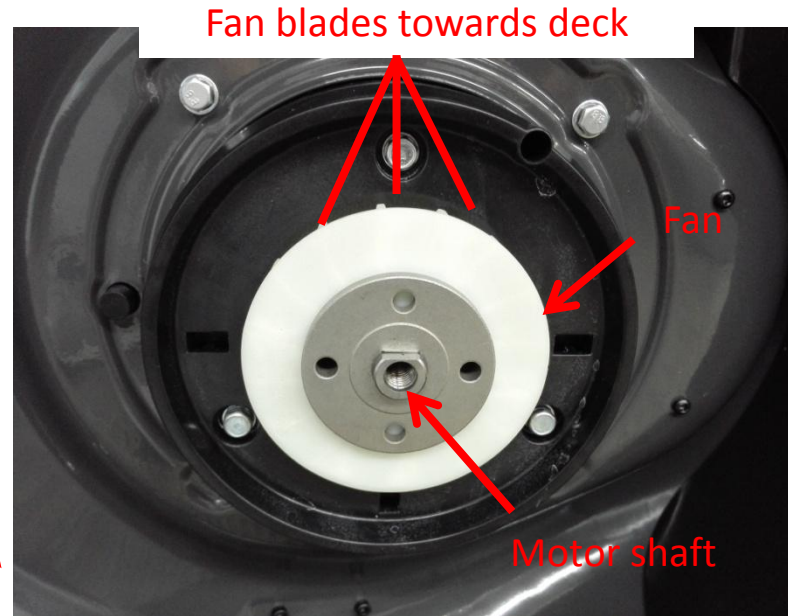
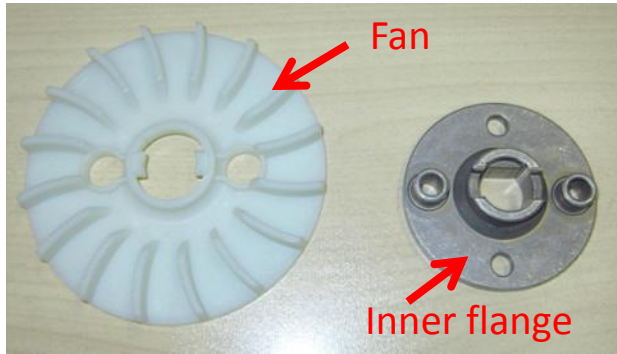

2. Blade Installation

LM2010E Lawn Mower

3. Mount the blade onto the inner flange with the surface stating "THIS SIDE FACING GRASS" facing outwards (Fig. 1) .
4. Aligning the flat position of the outer flange with the corresponding flat position on the motor shaft, mount the outer flange in place(Fig. 2).

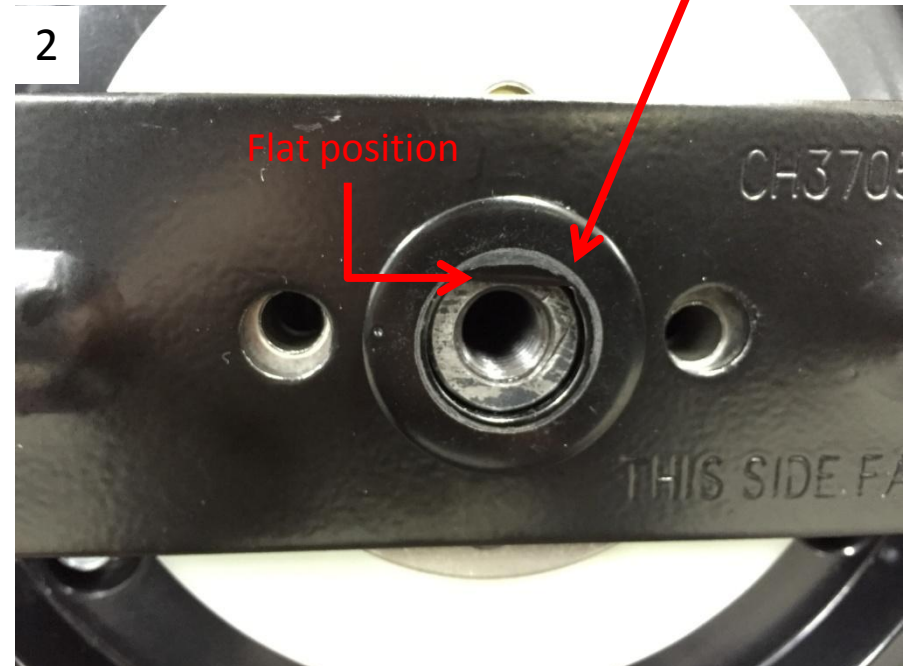
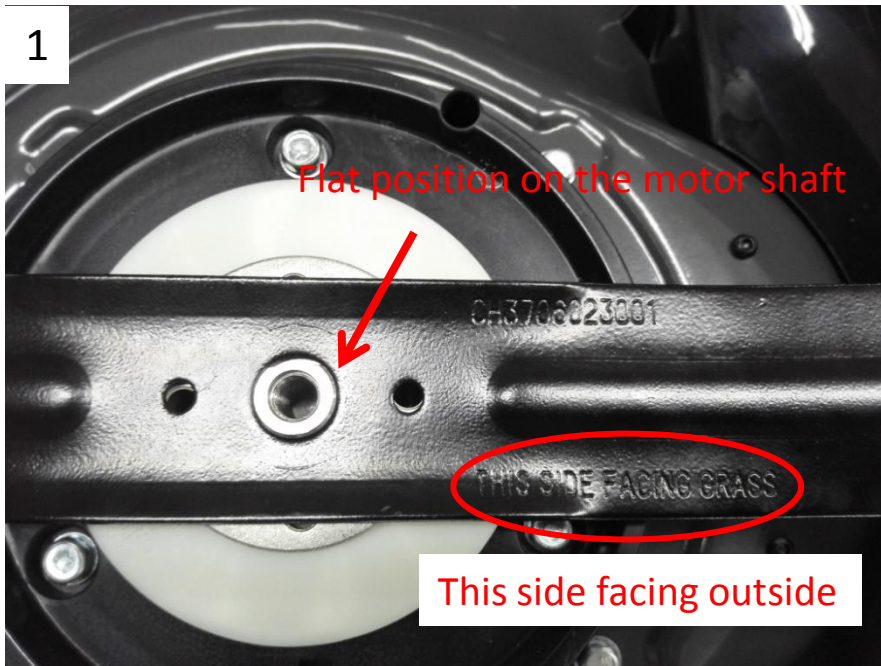
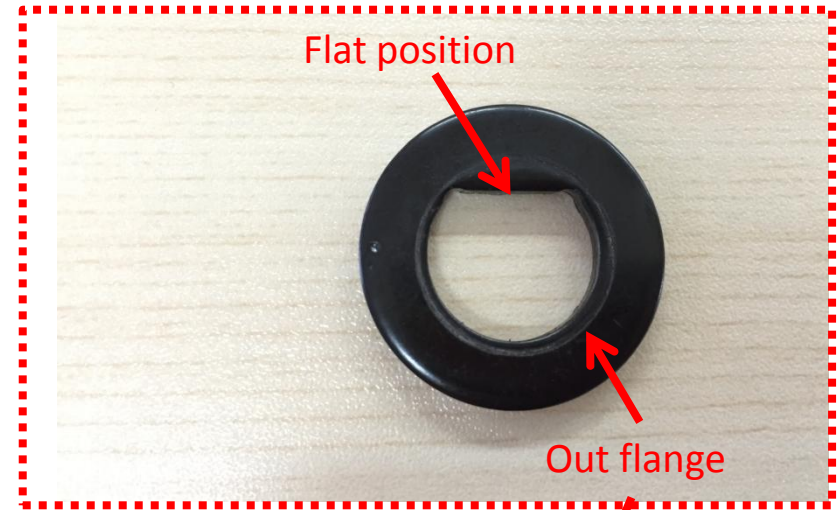

2. Blade Installation

- 5. Mount the bolt into the shaft and pre-tighten it in a clockwise direction by hand.

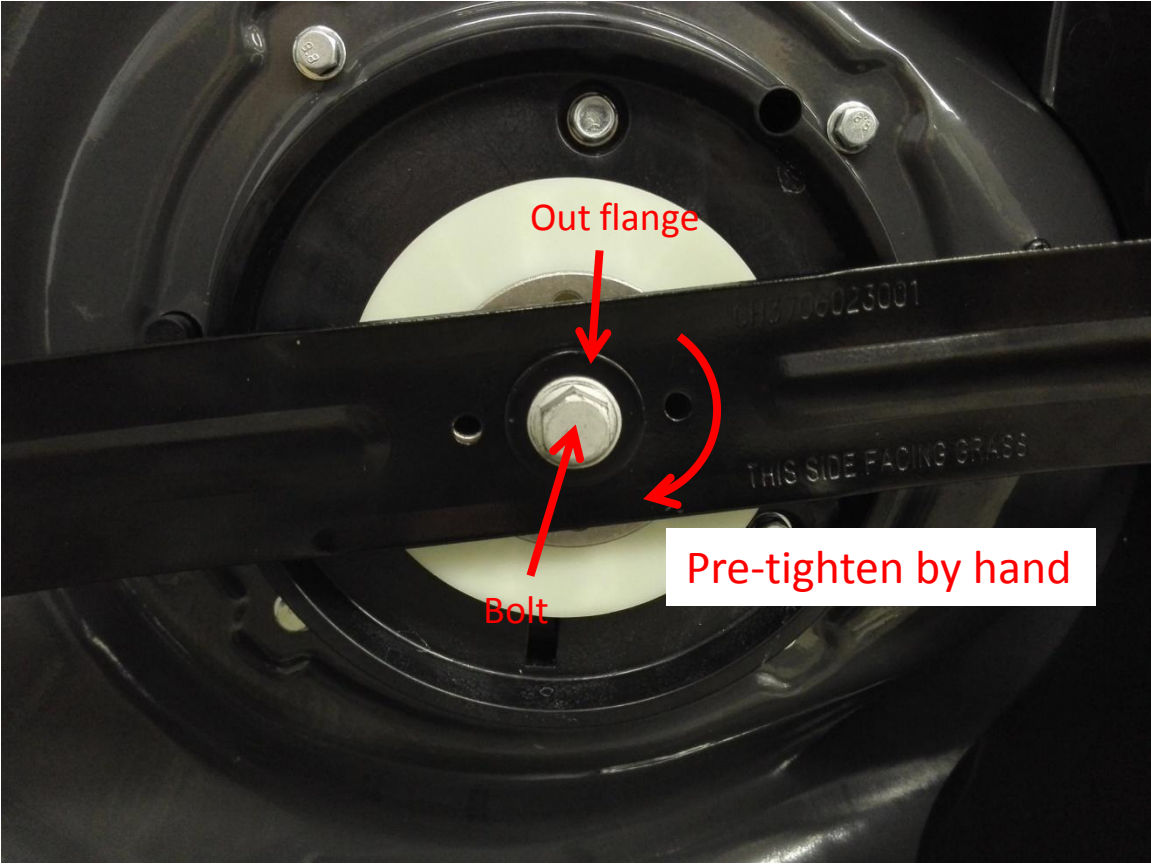

2. Blade Installation

LM2010E Lawn Mower

6. Turn the blade by hand to align the holes in blade with the through holes in the inner flange(Fig. 1).
7. Place a metal rod (e.g. a thin bit) with a diameter less than 6.35mm into the aligning holes to act as a stabilizer. Place another metal rod (e.g. a thick bit) with a diameter less than 11mm into the fixing hole on the deck to act as another stabilizer(Fig. 2).
8. Use a torque wrench(S=14mm) to tighten the bolt clockwise. The recommended torque for the blade bolt is $50 \pm 5\text{N}\cdot\text{m}$.

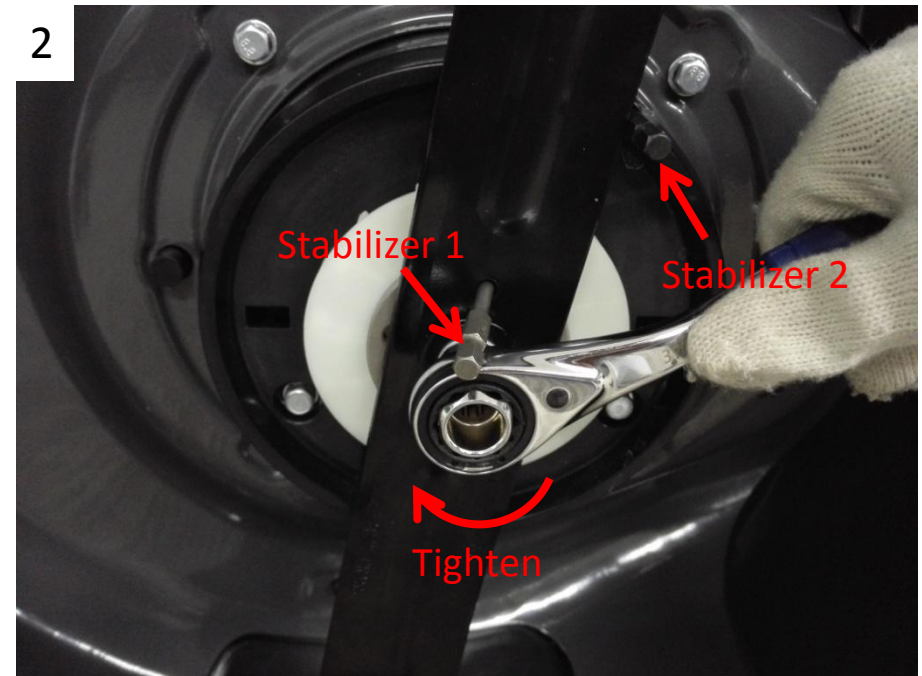
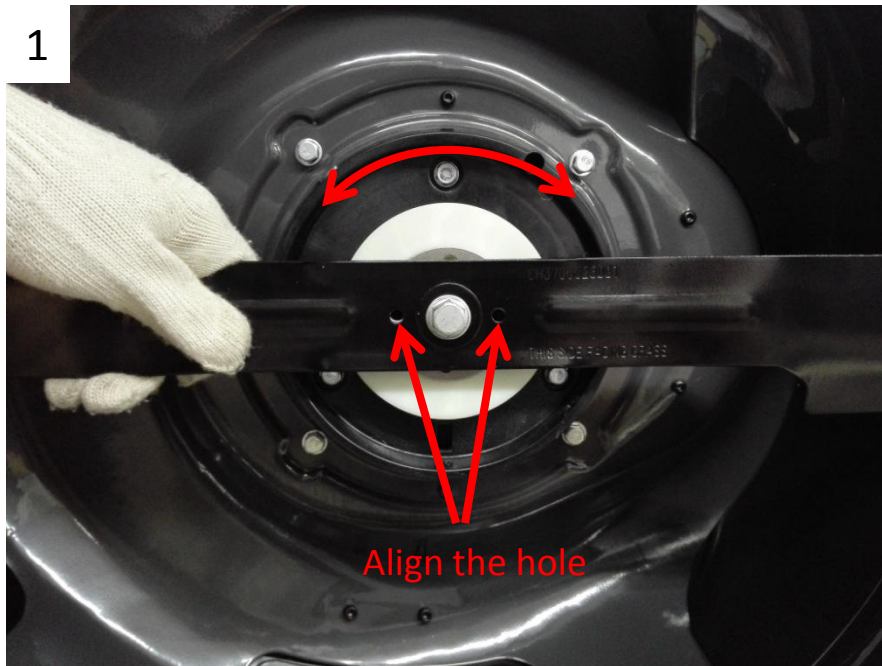

THE END

REPAIR GUIDELINE

PART 2: Side Discharge Door Replacement_LM2010E Lawn Mower



Side Discharge Door Replacement



Side discharge door

Description	Part Number
Side Discharge Door	3127965001

Side Discharge Door Replacement

LM2010E Lawn Mower

1. Turn the mower on its back and remove the hexagon socket screws from the mower deck.
2. Take down the side discharge door assembly from the mower deck.



Description	Part Number	SPEC	Qty
Hexagon socket screw	5620213003	M5X10	2

Side Discharge Door Replacement

- 3. Pull out the shaft from the right side of side discharge door (Fig. 1).
- 4. Remove the torsion spring from the side discharge door (Fig. 2).

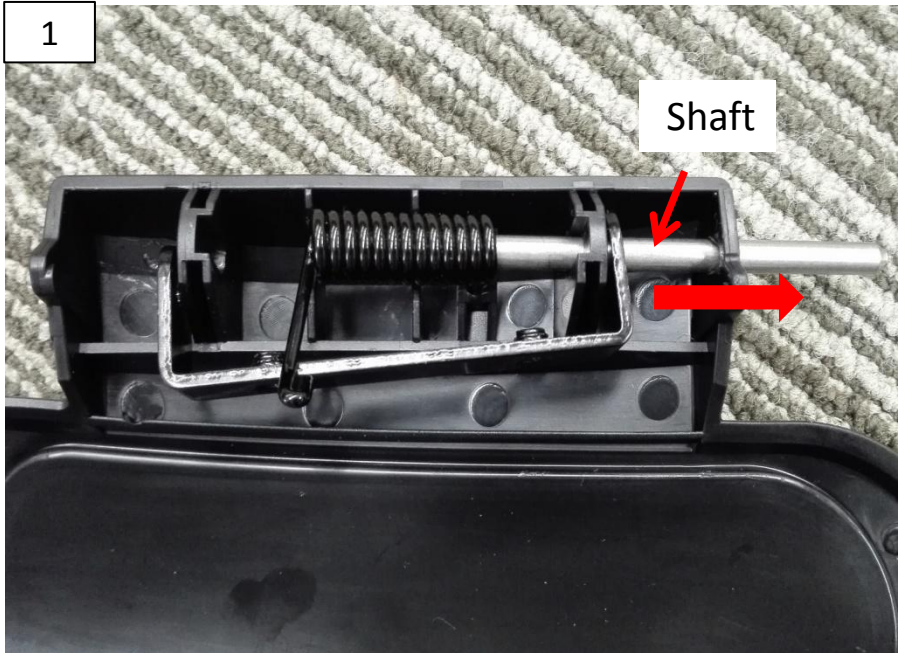

Description	Part Number	SPEC
Shaft	5670384001	Φ6x120
Torsion Spring	3660607001	-

Side Discharge Door Replacement

5. Replace with a new side discharge door, torsion spring or bevel support.



Description	Part Number	•SPEC
Bevel Support	3705862001	84x15x25

Side Discharge Door Replacement

- 6. Assemble the torsion spring, bevel support and shaft into the side discharge door cover following the figures below.

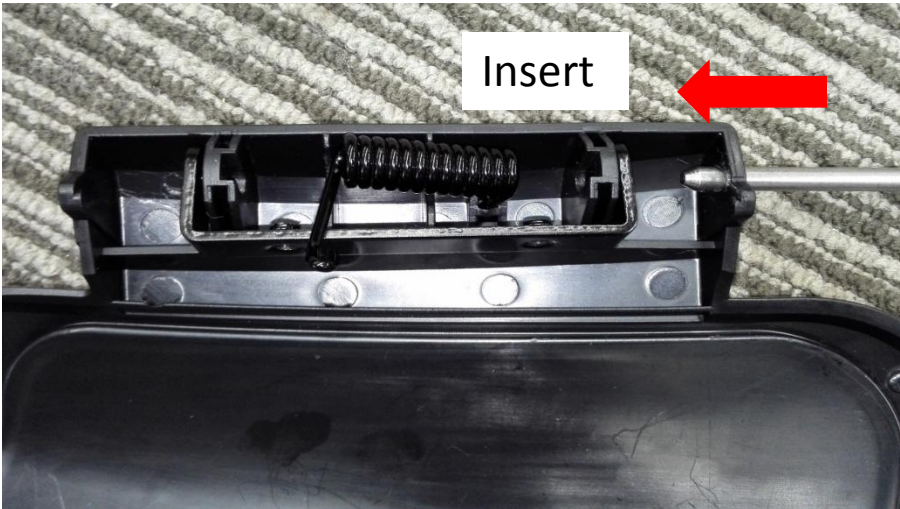
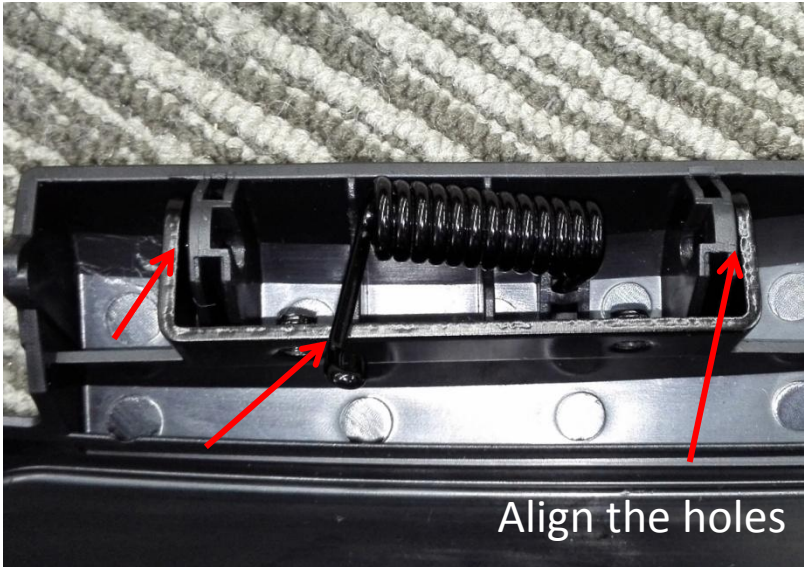

Side Discharge Door Replacement

7. Mount the side discharge door assembly onto the mower deck by tightening two hexagon screw.



THE END

REPAIR GUIDELINE

PART 3.1: Parts in Power Unit Replacement_LM2010E Lawn Mower



Table of Contents

NO.	Contents	Page
1	Power Unit Removal	3-8
2	Motor Assembly Replacement	9-20
3	Main PCBA Replacement	21-38
4	Power Unit Assembly	39-44

1. Power Unit Removal

1. Before replacing or maintaining the parts in power unit or self-propelled unit, loosen the two screws to remove the service cover from the mower.



Description	Part Number	SPEC	Qty
Service Cover	3127947001	-	1
Tapping Screw	5620157006	M4.2x19	2

1. Power Unit Removal

LM2010E Lawn Mower

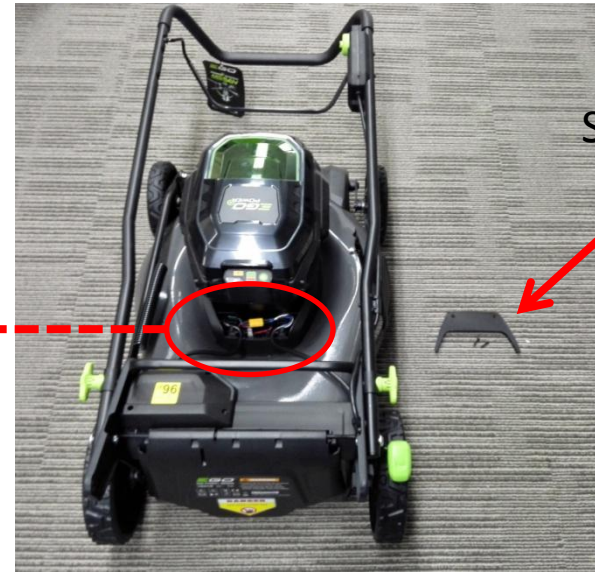
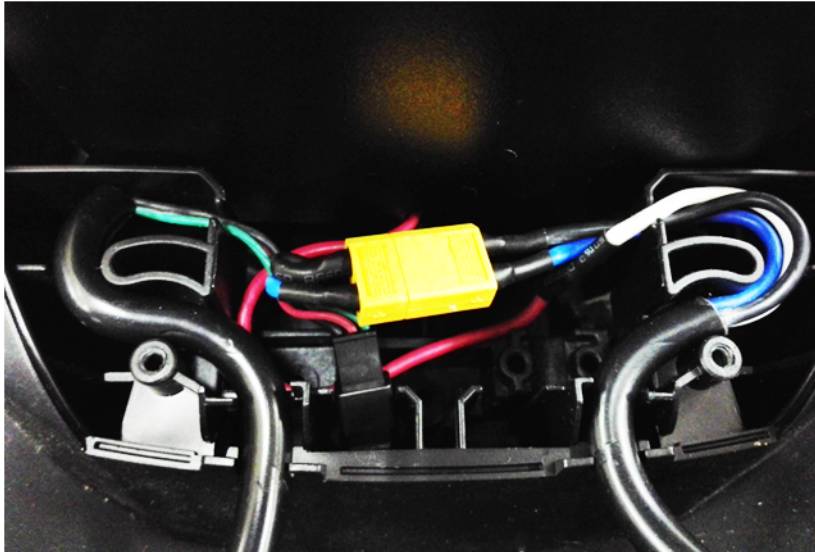

Service Cover

2. Turn the mower on its side and remove the blade, and fan together with the inner flange from the motor shaft as Part 1 show.

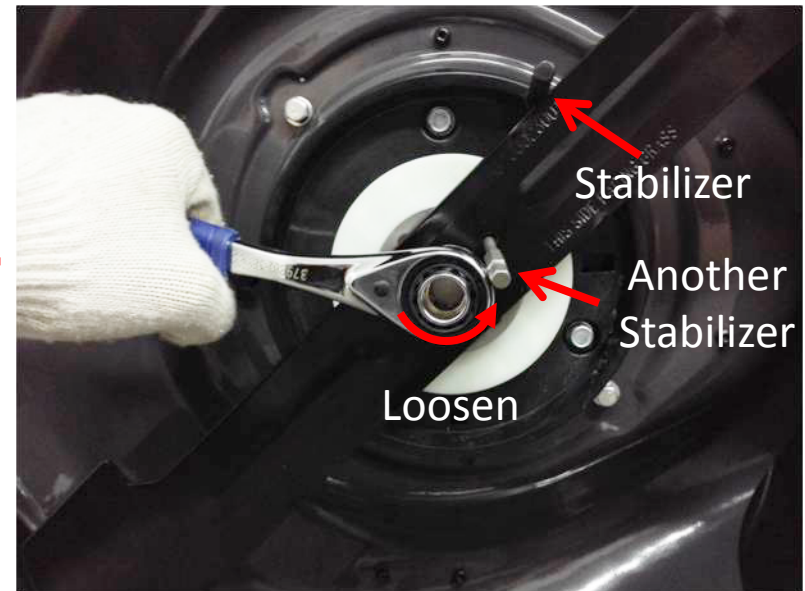

Stabilizer

Another Stabilizer

Loosen

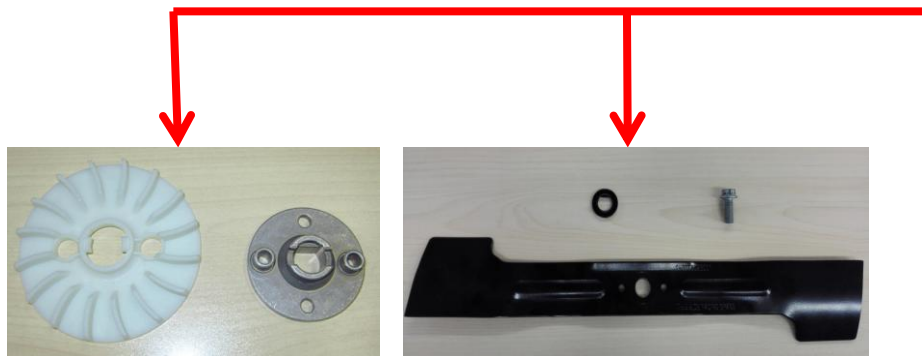

1. Power Unit Removal

The following parts can be replaced only when the service cover is removed from the mower.

Description	Part Number
DC Motor	2730239001
Main PCB Assembly	2830119002

1. Power Unit Removal

- Loosen the 4 hexagon head bolts with a socket wrench (S=10mm).

WARNING: During this process, there is a risk of power unit dropping. The power unit must be supported.

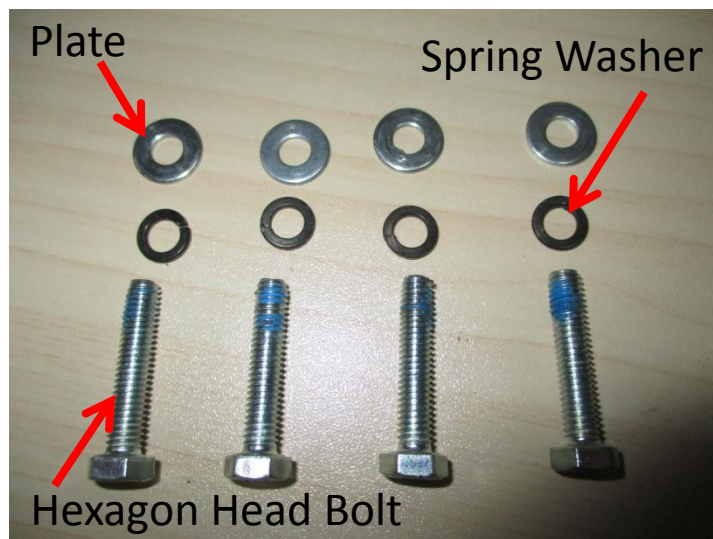

Description	Part Number	SPEC	Qty
Hexagon Head Bolt	5640008003	M6×30	4
Spring Washer	5650168001	-	4
Plate	3700076001	-	4

1. Power Unit Removal

4. Separate the power unit from the mower by disconnecting the wires linking with the main switch and handle position switch.

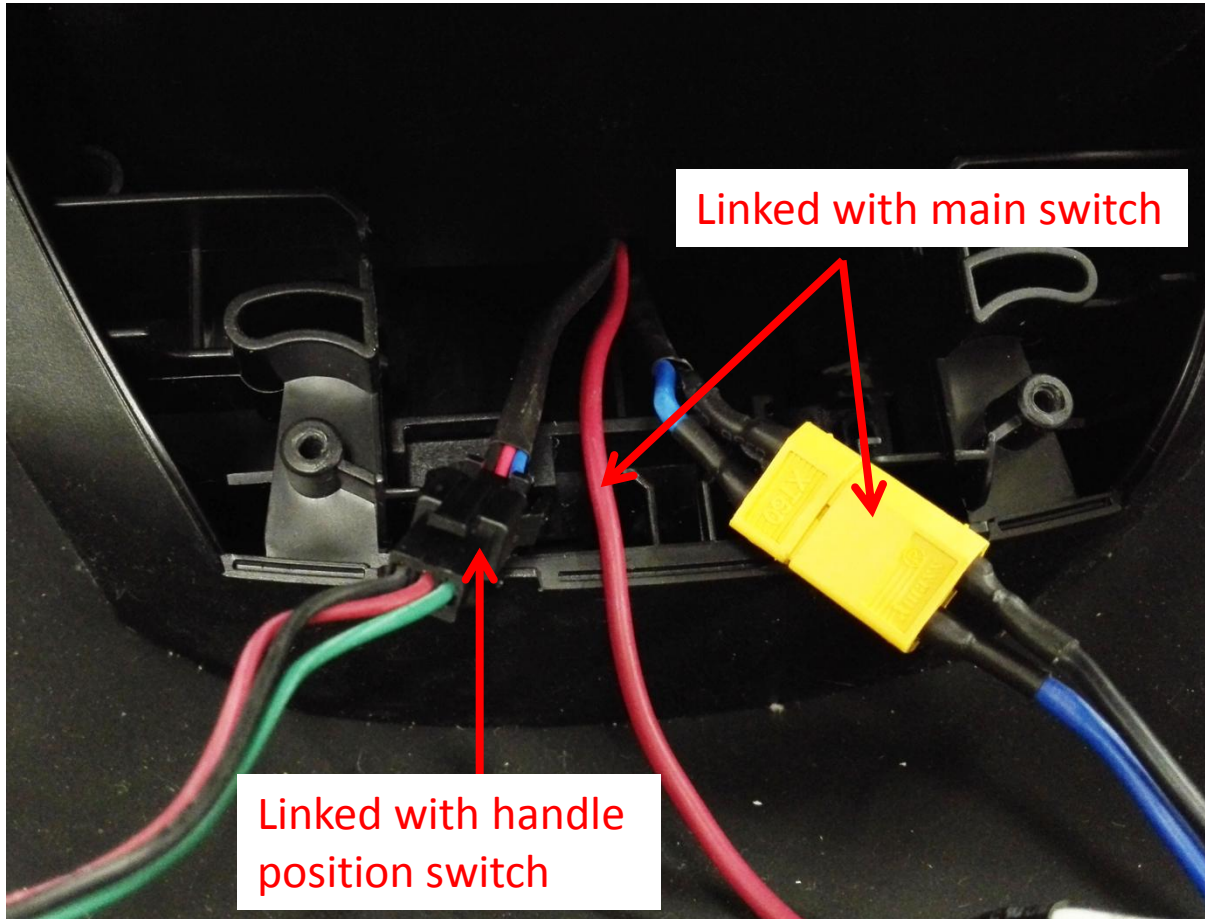

1. Power Unit Removal

5. Remove the power unit from the mower.



2. Motor Assembly Replacement

LM2010E Lawn Mower

1. Open the battery cover and stabilize it using a manual screwdriver. Then loosen the 5 screws to remove the inner cover(Picture see next slide).



Description	Part Number	SPEC	Qty
Battery cover	3127880001	-	1
Inner cover	3127879001	-	1
Tapping screw	5610042014	4.2x19	5

2. Motor Assembly Replacement

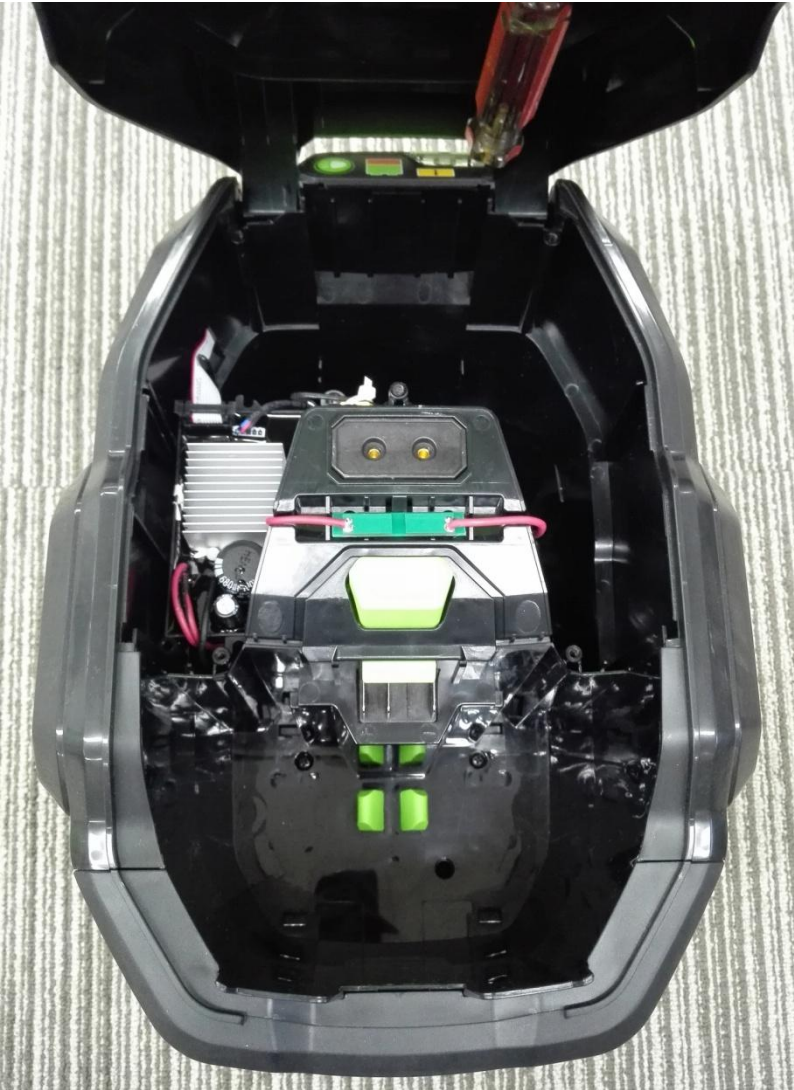

2. Motor Assembly Replacement

LM2010E Lawn Mower

2. Remove the zip tie and foil to separate the temperature sensor from the motor wire.

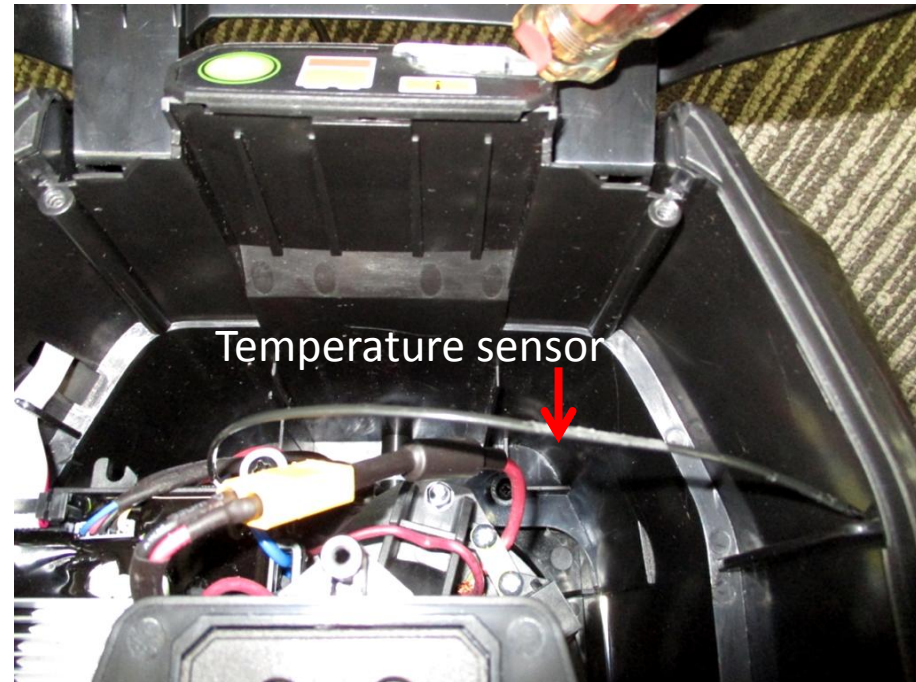
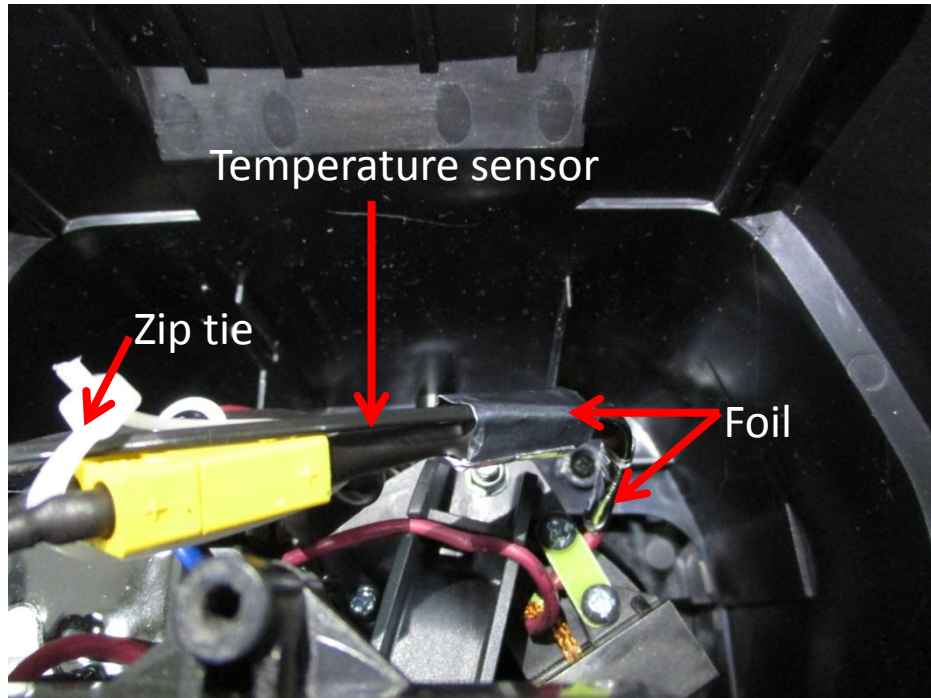

2. Motor Assembly Replacement

LM2010E Lawn Mower

3. Disconnect the yellow plug.
4. Test the motor by connecting the motor cables (The yellow plug) to a DC supply (43VDC). If the motor doesn't run, replace the motor. Otherwise check other possible cause, e.g. PCBA.

WARNING: Before turning on the motor, make sure the blade is disassembled.

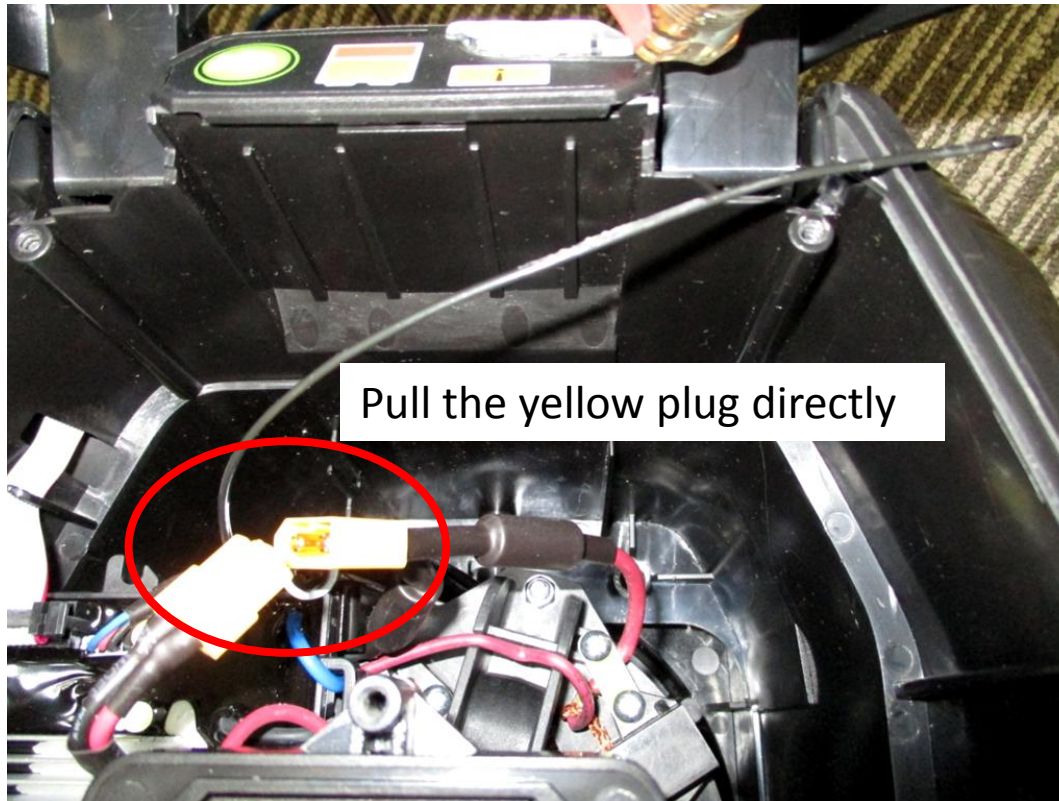

2. Motor Assembly Replacement

- 5. Remove the 5 screws (2 deep in the battery box) to separate the motor and base from the battery box.

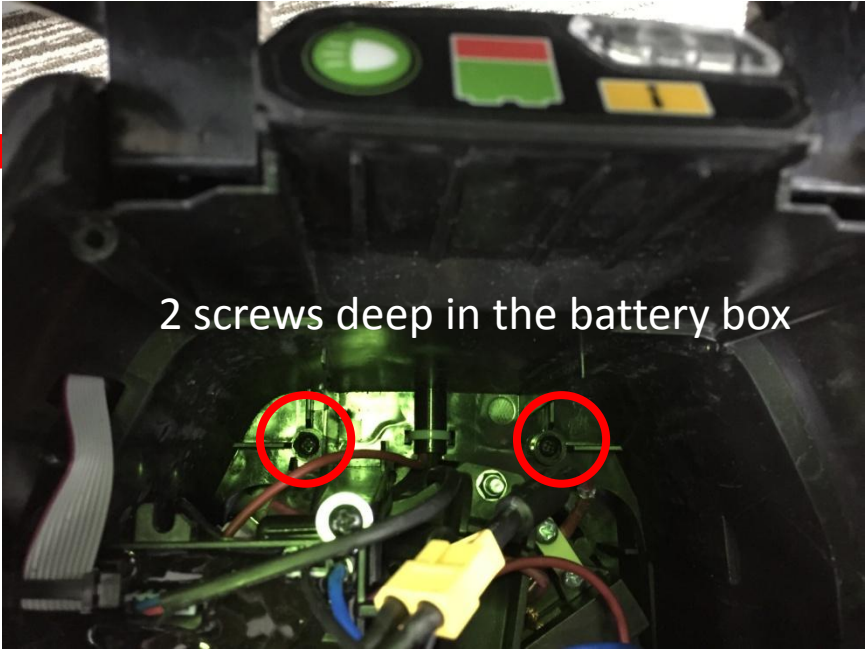
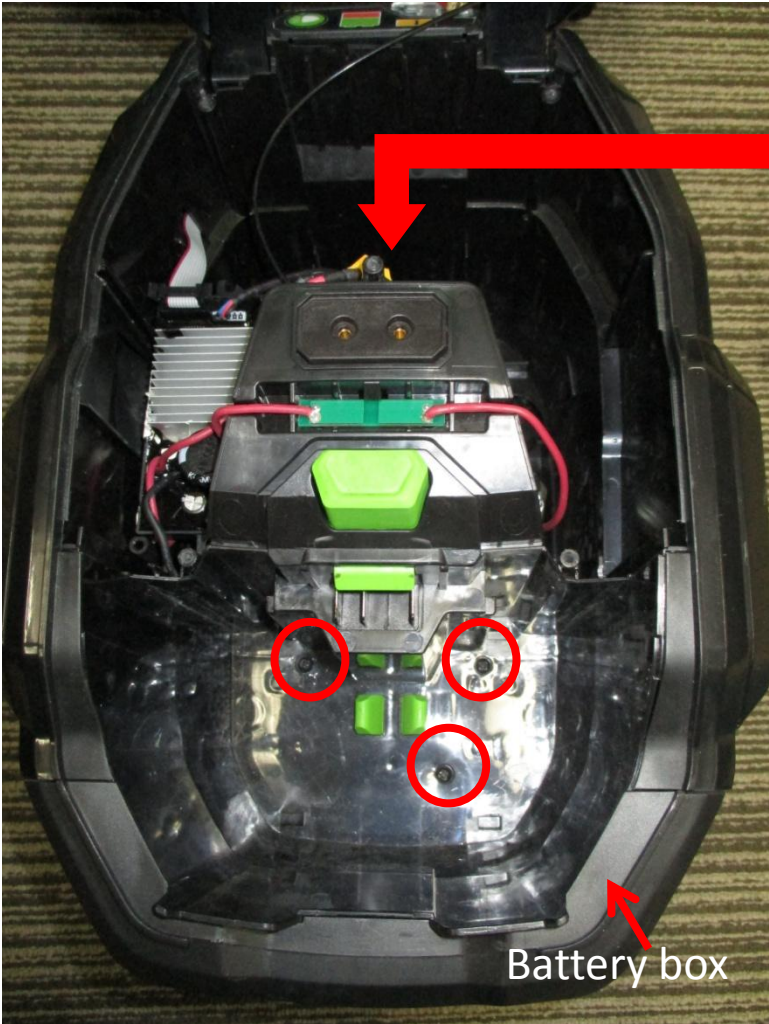

Description	Part Number	SPEC	Qty
Battery box	31278810 01	-	1
Tapping screw	56100420 14	4.2x19	5

2. Motor Assembly Replacement

6. Cut the white zip ties with diagonal pliers to remove the motor and base from the battery box.

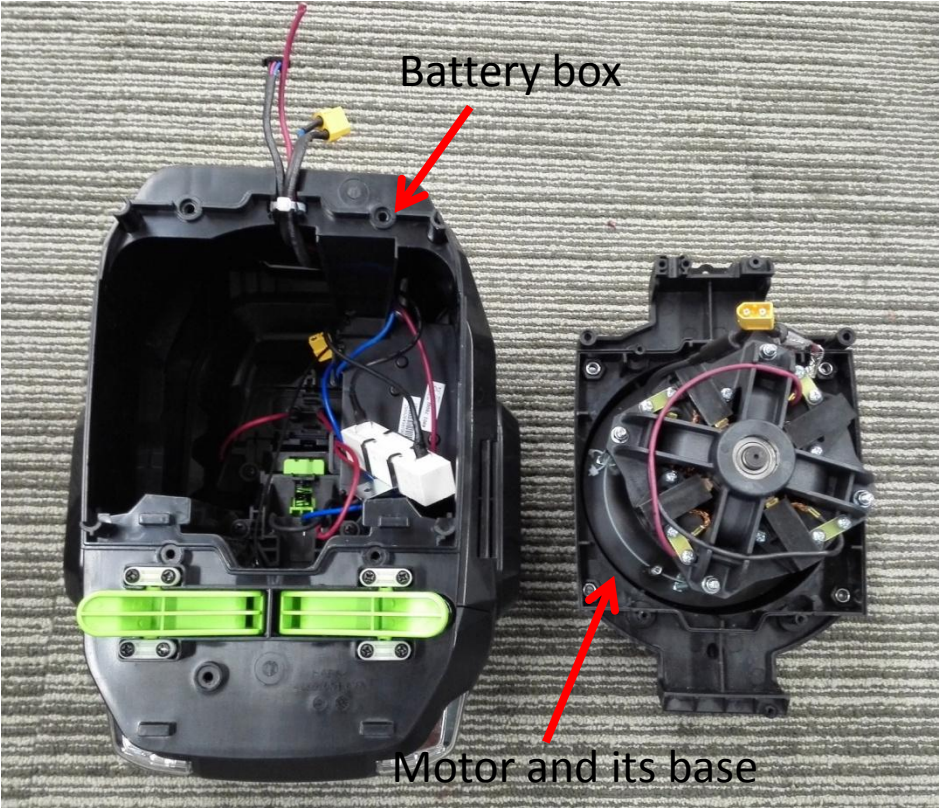
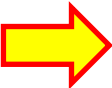
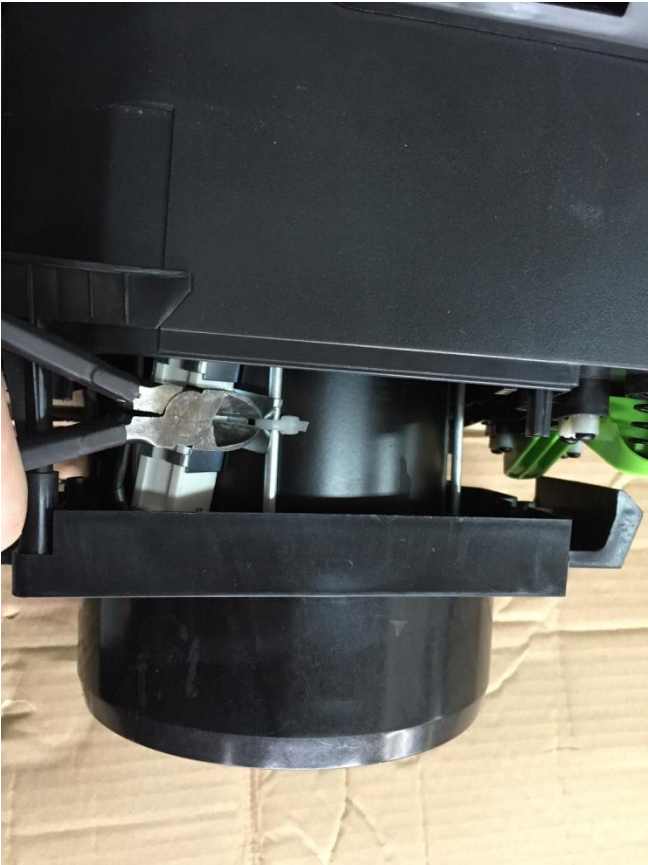

2. Motor Assembly Replacement

LM2010E Lawn Mower

- Remove the 3 hex bolts, spring washers and plates with a socket wrench (S=10mm) to separate the motor from the motor base.

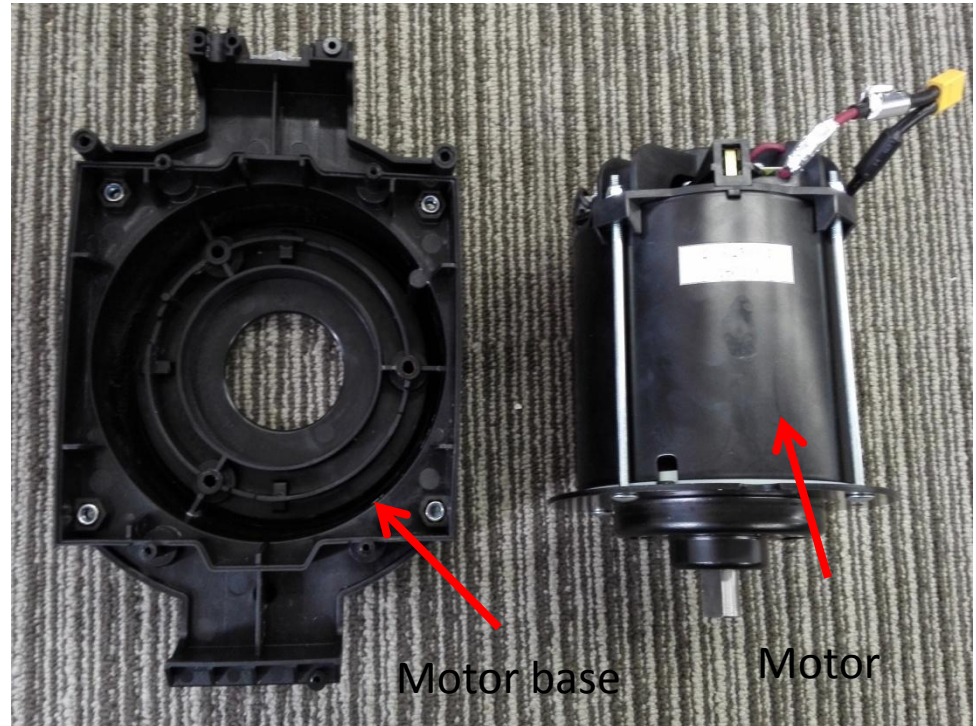
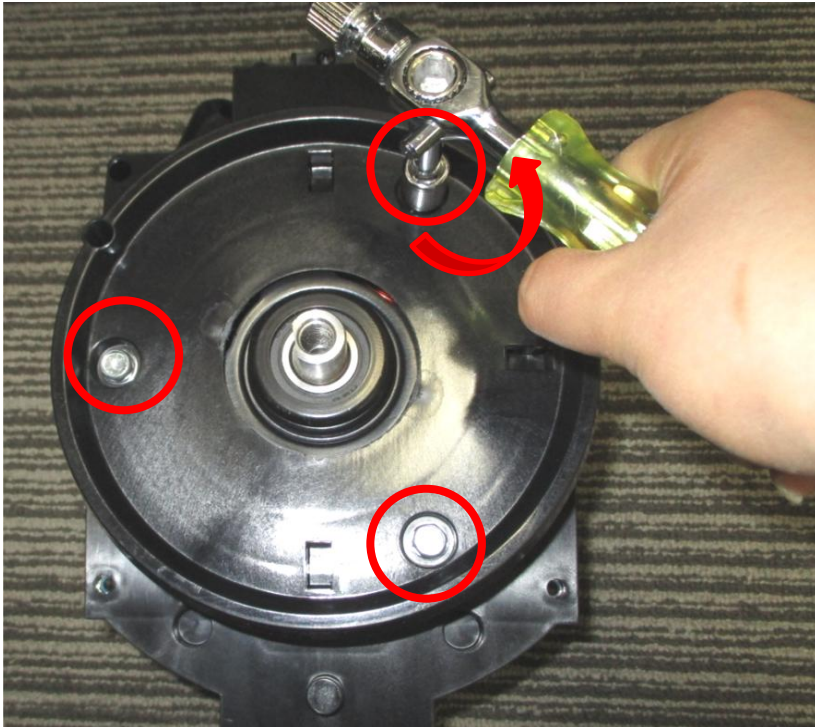

Description	Part Number	SPEC	QTY
Hex bolt	5640008003	M6×30	3
Spring washer	5650168002	-	3
Plate	3700076001	-	3
Motor	2730239001	-	1



2. Motor Assembly Replacement

LM2010E Lawn Mower

8. To fit a new motor, align the locating notch on the motor with the locating pin on motor base to position the motor into place (Fig. 1).
9. Turn the motor shaft upside to fix the motor onto the motor base by tightening 3 hex bolts(Fig. 2).

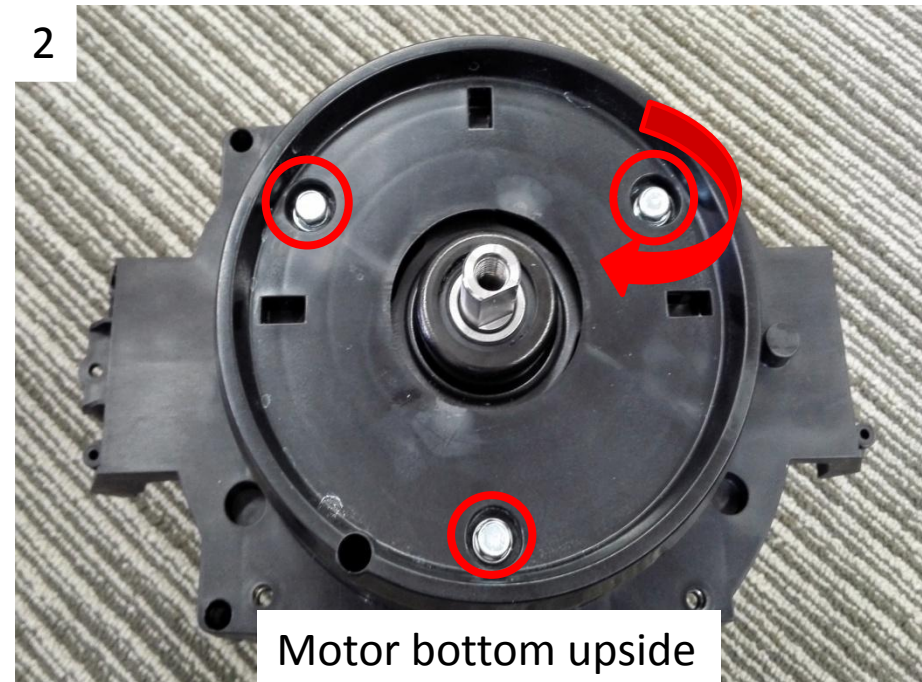
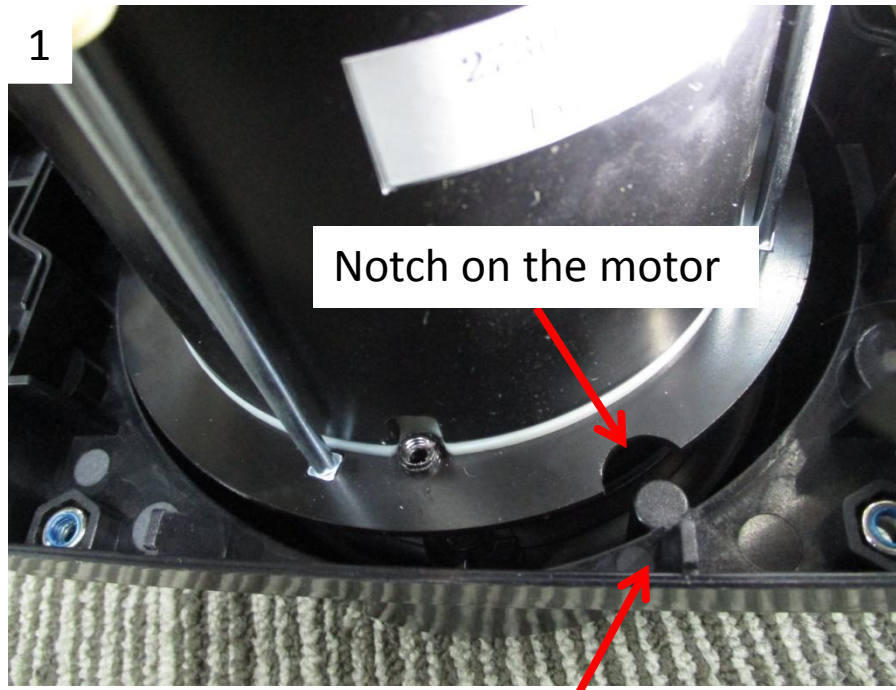

2. Motor Assembly Replacement

LM2010E Lawn Mower

10. Place the motor and the battery box on their side.

NOTICE: THE GREEN LEVER SHOULD FACE THE MOTOR BASE WITH RIB.

11. Insert the motor into the battery box. When half of the motor is inserted, tie the large resistor to the motor body with a zip tie. Cut the excess zip tie.

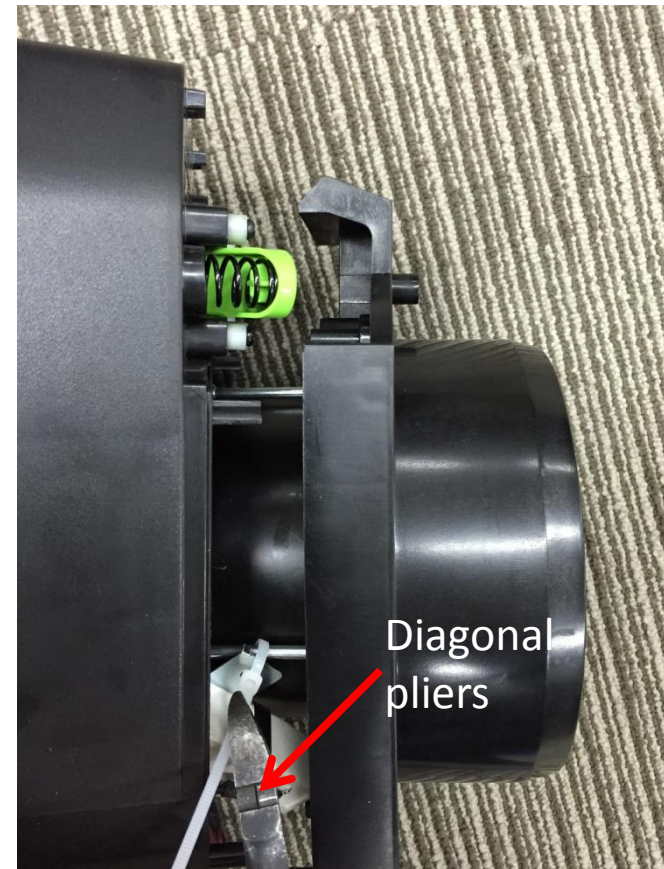
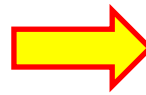
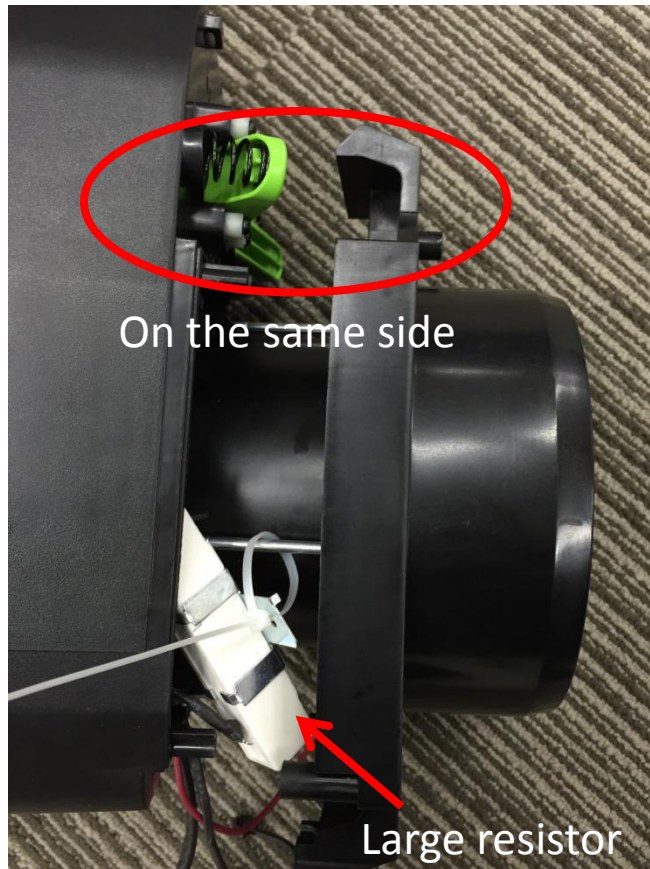

2. Motor Assembly Replacement

LM2010E Lawn Mower

11. Complete inserting the motor into the battery box until completely loaded.

NOTICE: The another four bolts should not be mounted now.

14. Reverse the whole set to lock them using the inside 5 screws(2 screws deep in the battery box).



Reverse the
whole set

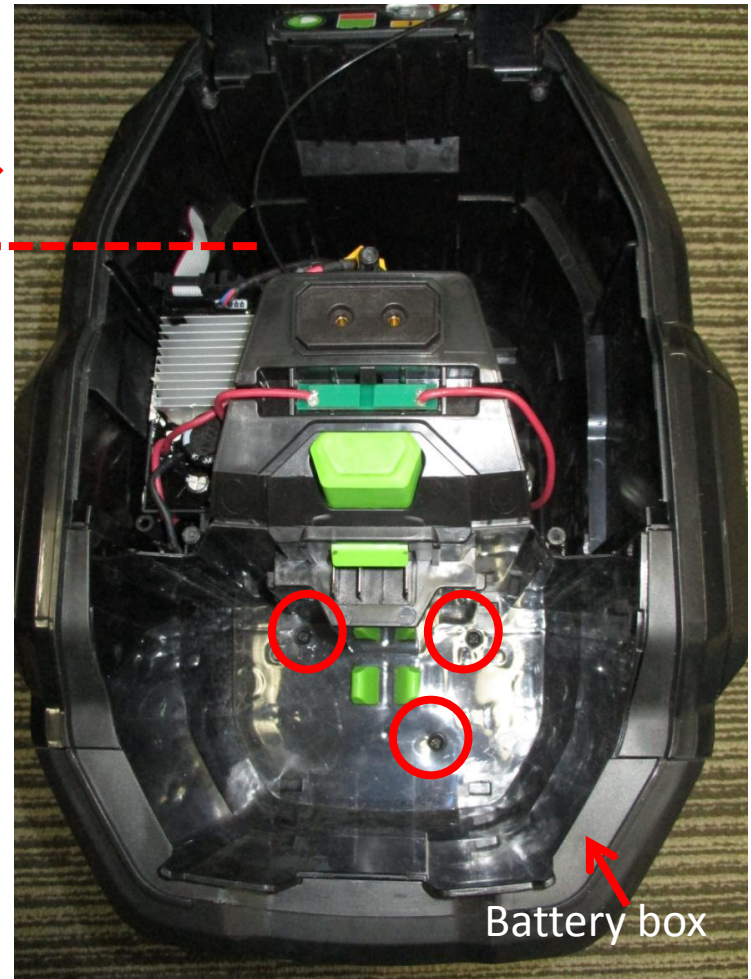

The mounting place of
another four bolts

2 screws deep in
the battery box

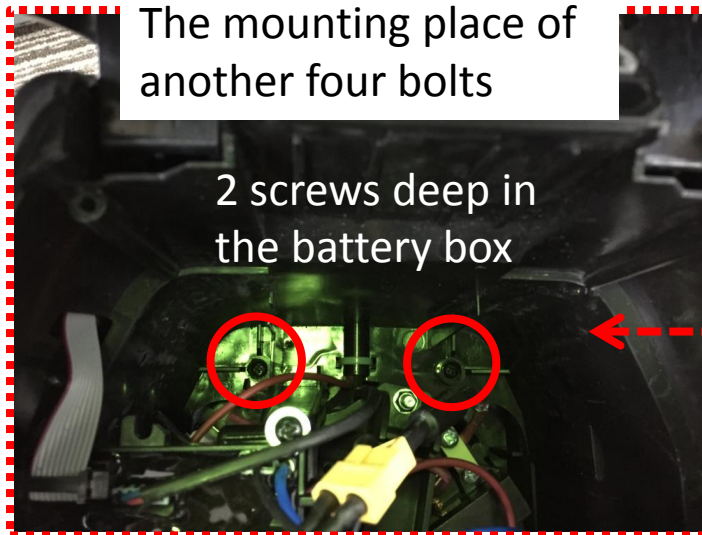

2. Motor Assembly Replacement

LM2010E Lawn Mower

15. Connect the yellow plug. **NOTE “+” to “+”.**
16. Paste the temperature sensor onto the motor red wire at the wire root and stabilize it by another piece foil at any other position on the red wire.
17. Tighten the yellow plug and the temperature sensor with a zip tie.

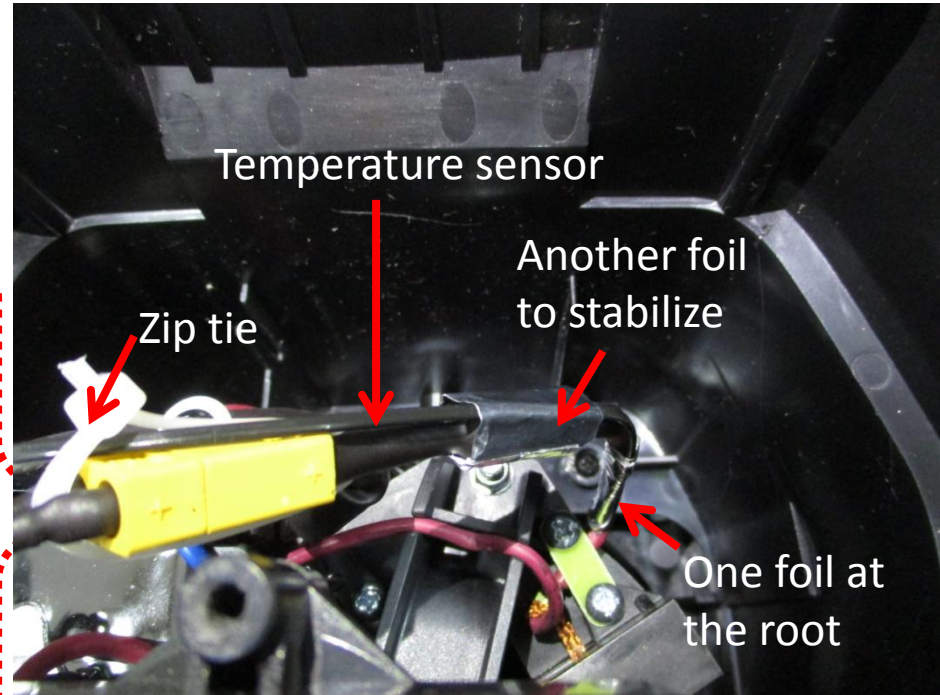
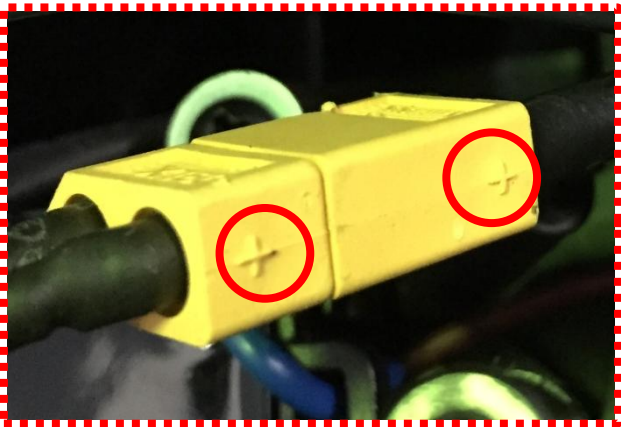

2. Motor Assembly Replacement

LM2010E Lawn Mower

Detailed requirements for temperature sensor assembly:

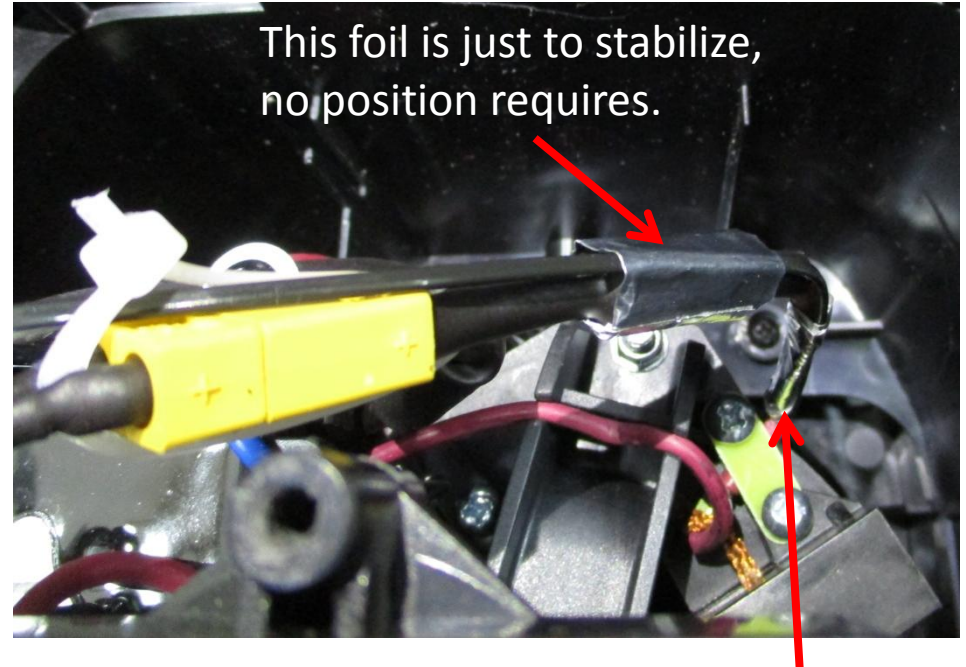
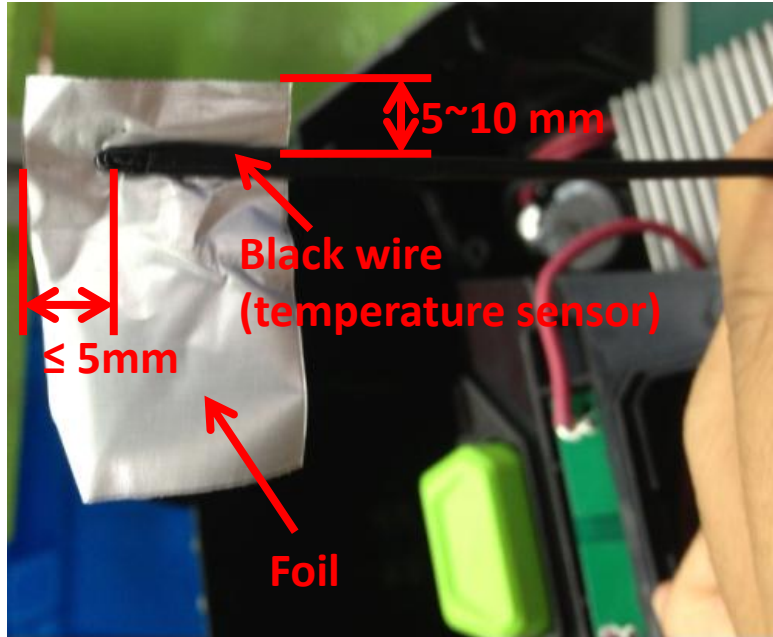

This foil is to paste the sensor onto the red wire root.

NOTICE: 2pcs of foil are required.

- ① The first one attached to the black temperature sensor should be pasted from the root of the red wire;
- ② The second one is to stabilize them, slightly away from the first one.

3. Main PCBA Replacement

- 1. Remove the motor as previous steps shown.
- 2. Remove the screw and plain washer as shown in the figure below.
- 3. It's easy to release the wire harness plug from its socket using pliers to depress both sides.

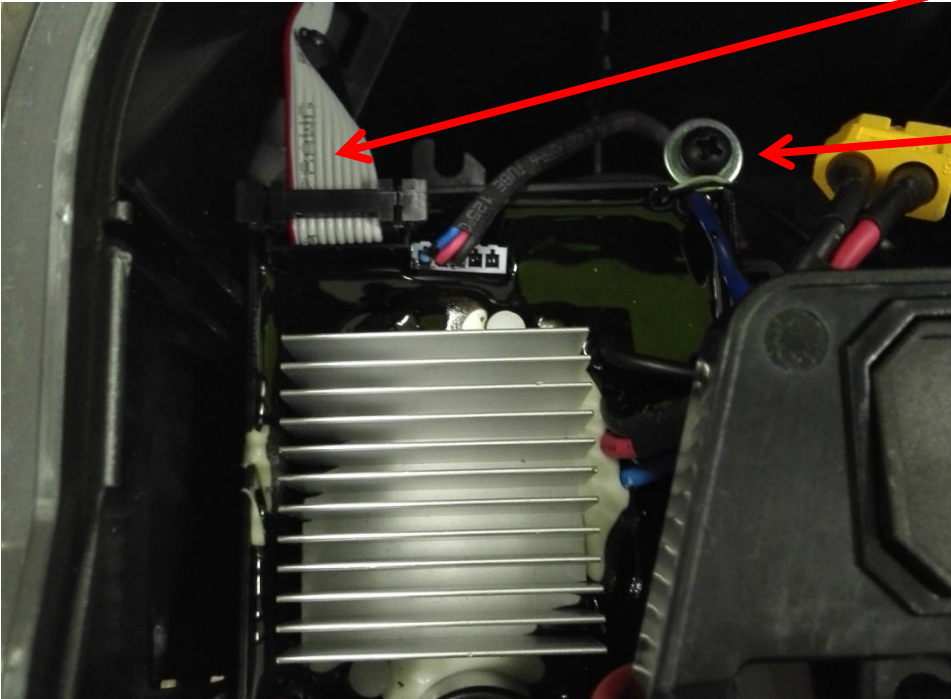
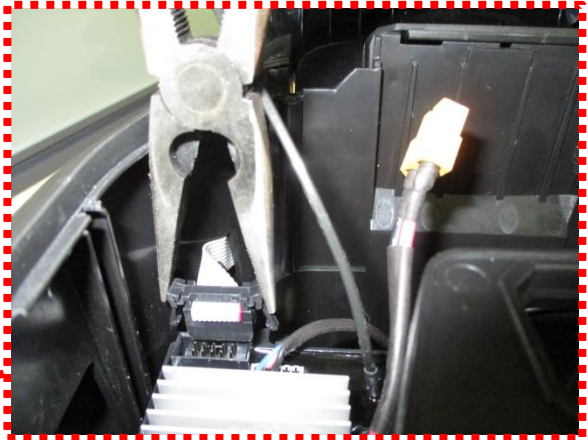

Description	Part Number	SPEC	Qty
Tapping screw	5610042014	4.2x19	1
Plain washer	5650004001	-	1
Wire harness plug	4930490001	-	1

3. Main PCBA Replacement

4. Remove the fuse set from the groove (Fig.1).
5. Measure the fuse with a multimeter. If it is open-circuit, meaning the fuse is broken. Replace a new PCBA following the below steps.

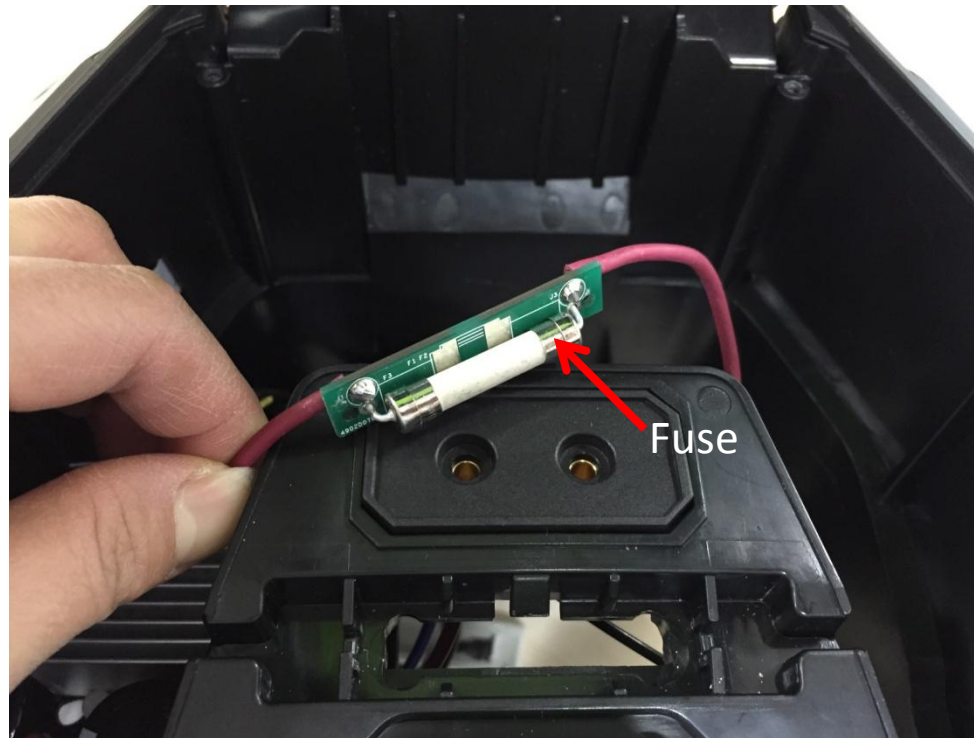

3. Main PCBA Replacement

6. Remove the key holder from the groove and remove the heat-shrinkable sleeves.

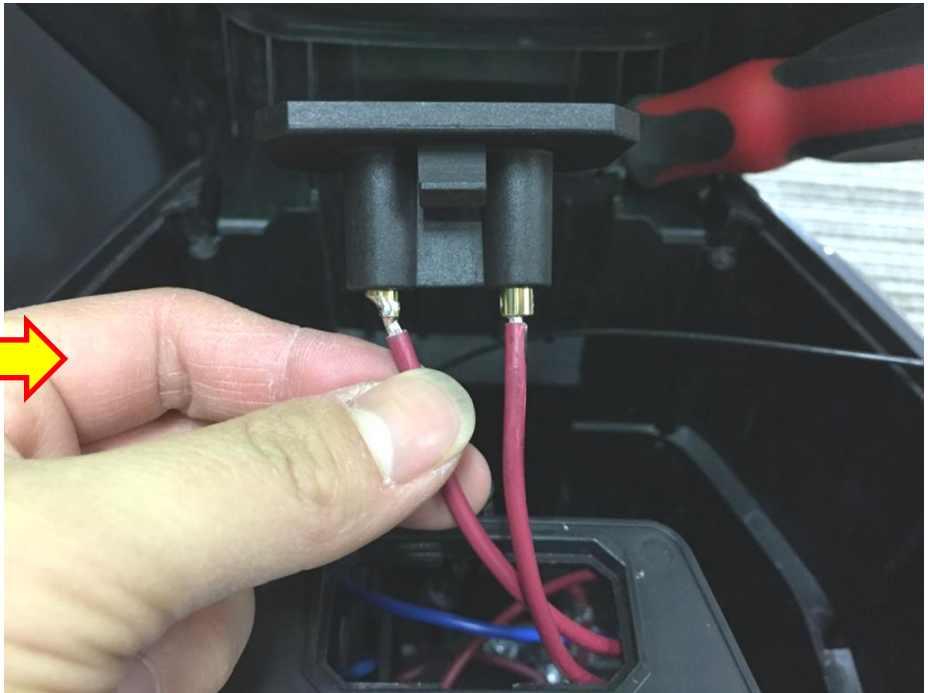
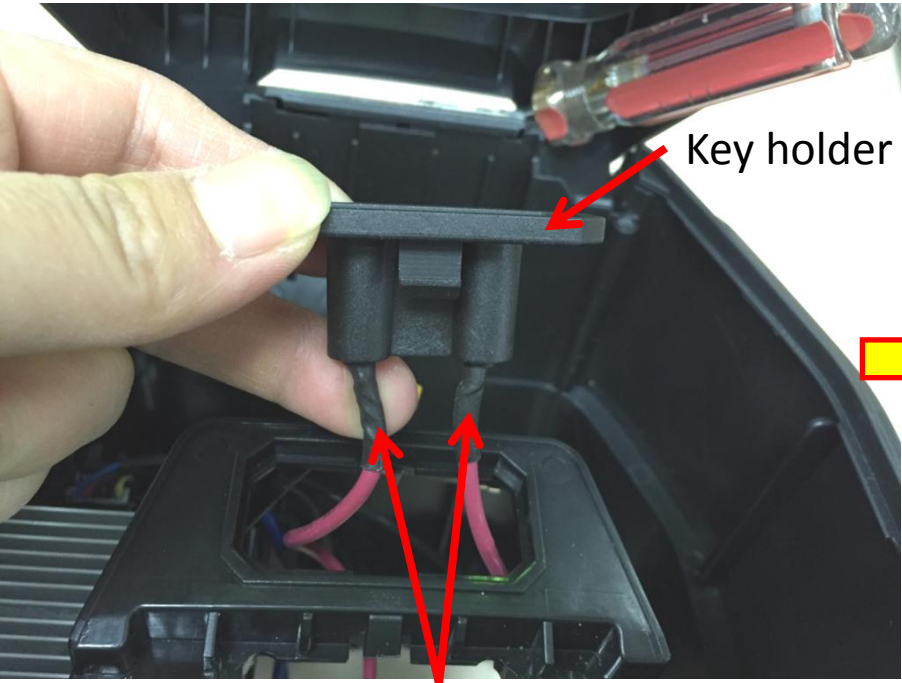

Heat-shrinkable sleeves

3. Main PCBA Replacement

7. Following the steps show, take the key holder apart from the battery box.

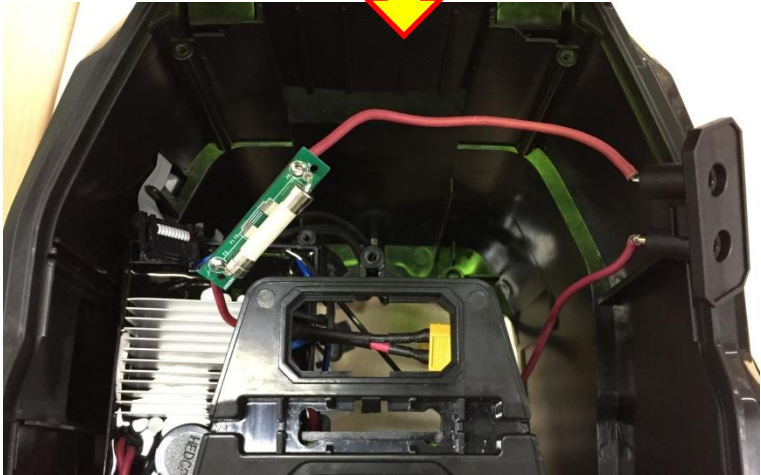
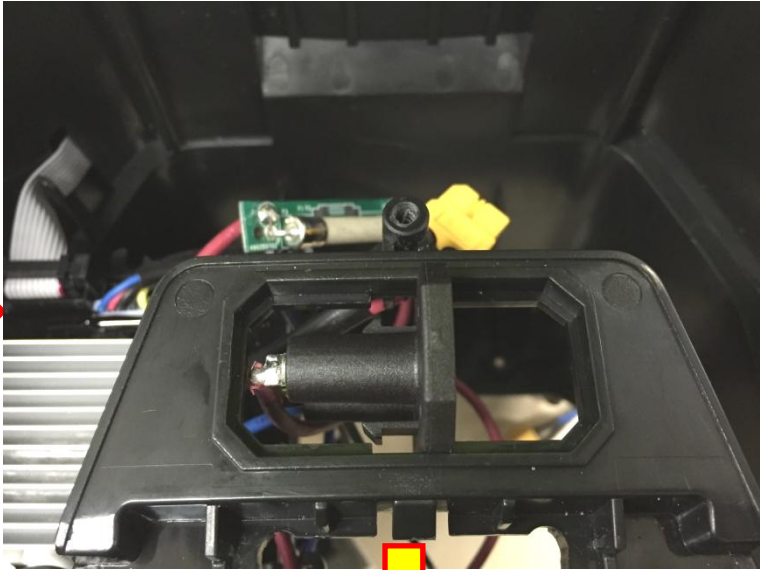
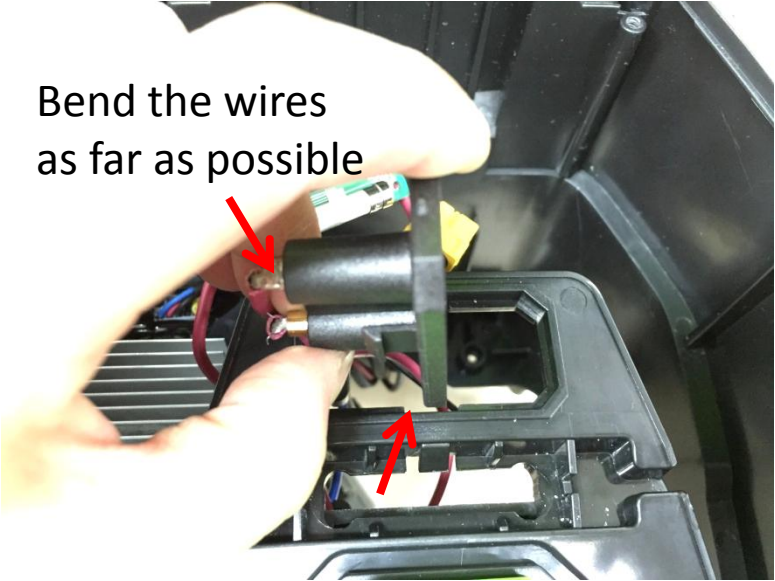

3. Main PCBA Replacement

- 8. Reverse the battery box to cut the zip tie on the battery box back(Fig.1).
- 9. Take the PCBA from the battery box and remove the 4 screws to separate the electric contact base from the battery box(Fig.2).

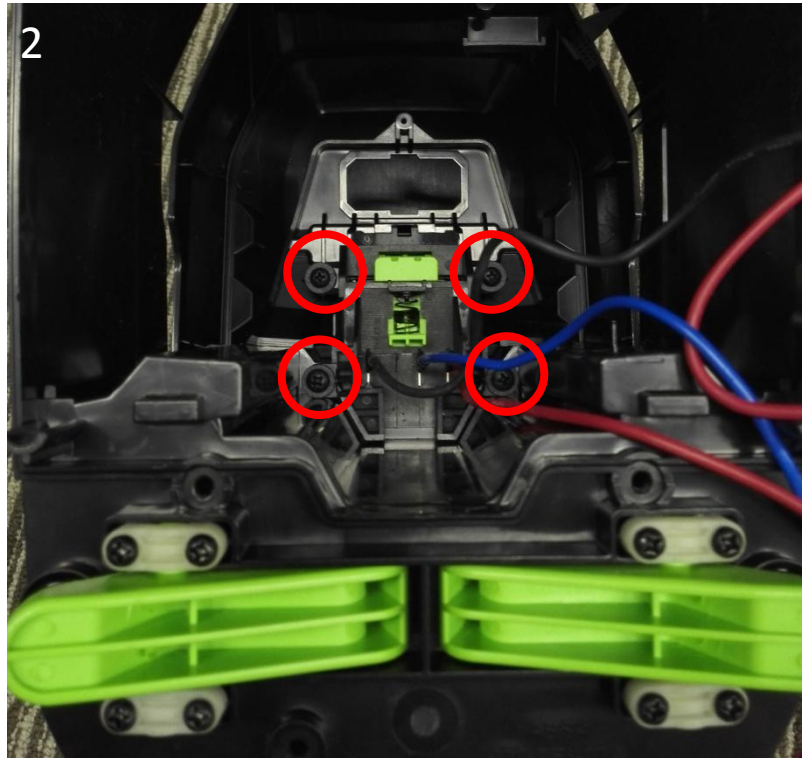
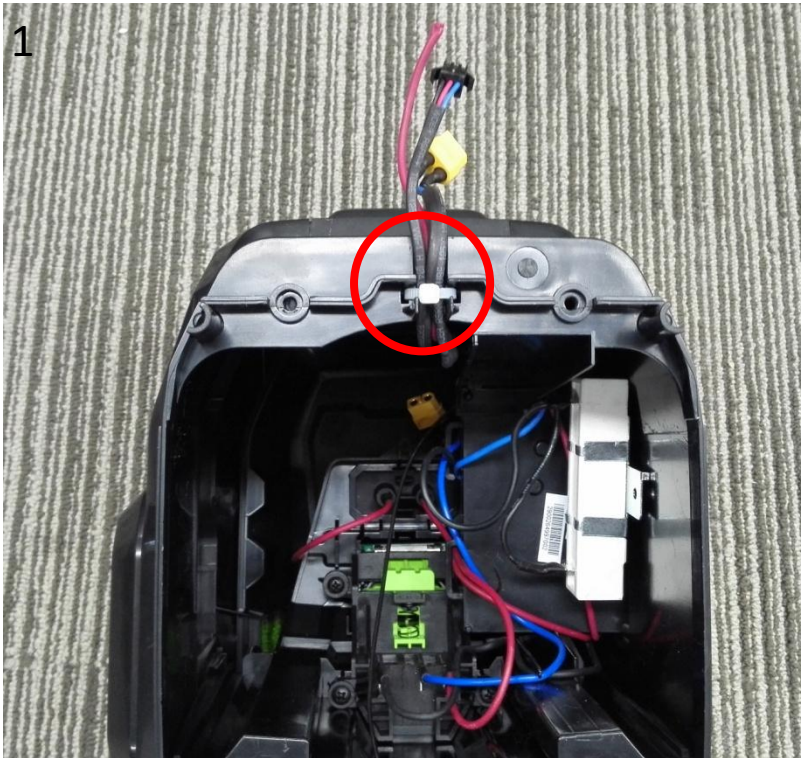

Description	Part Number	SPEC	QTY
Tapping screw	5610042014	4.2x19	4

3. Main PCBA Replacement

10. Separate the PCBA from the electric contact base.

Description	Part Number	QTY
Electric contact base	3126782001	1

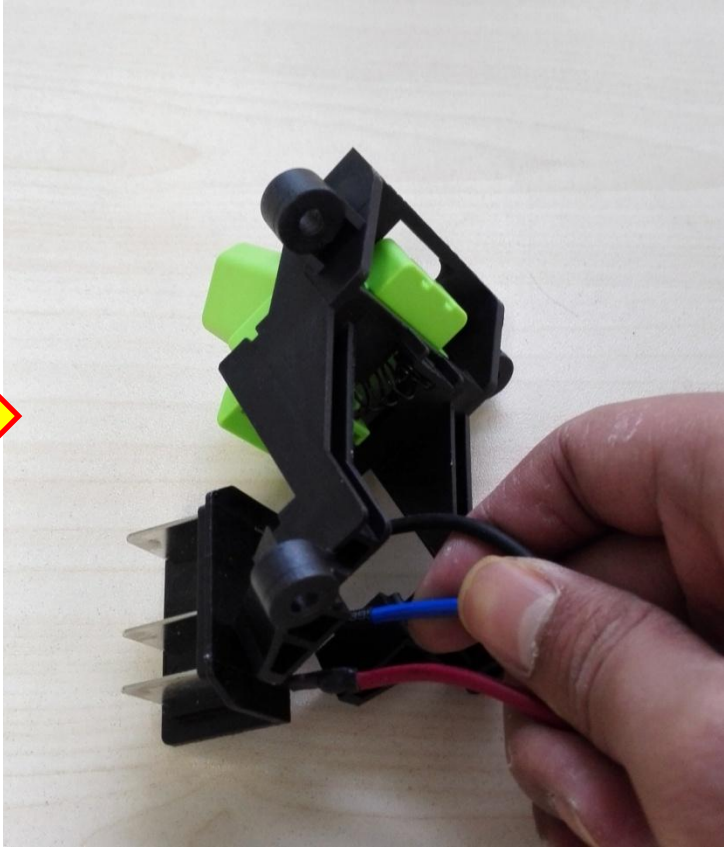
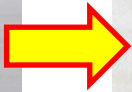
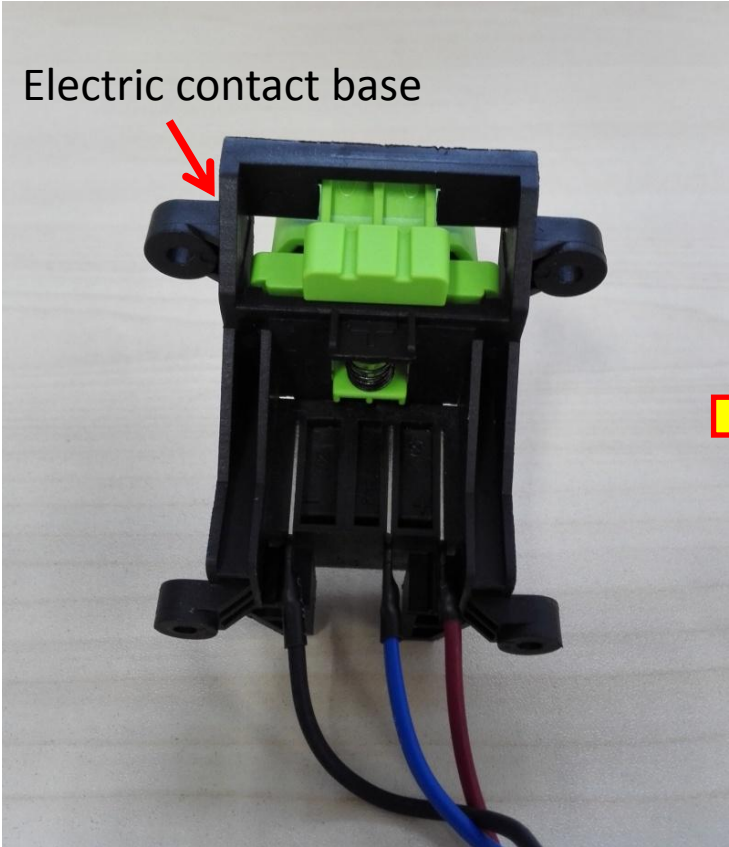

3. Main PCBA Replacement

11. PCBA with key holder and the electric contact base set are as following pictures show.

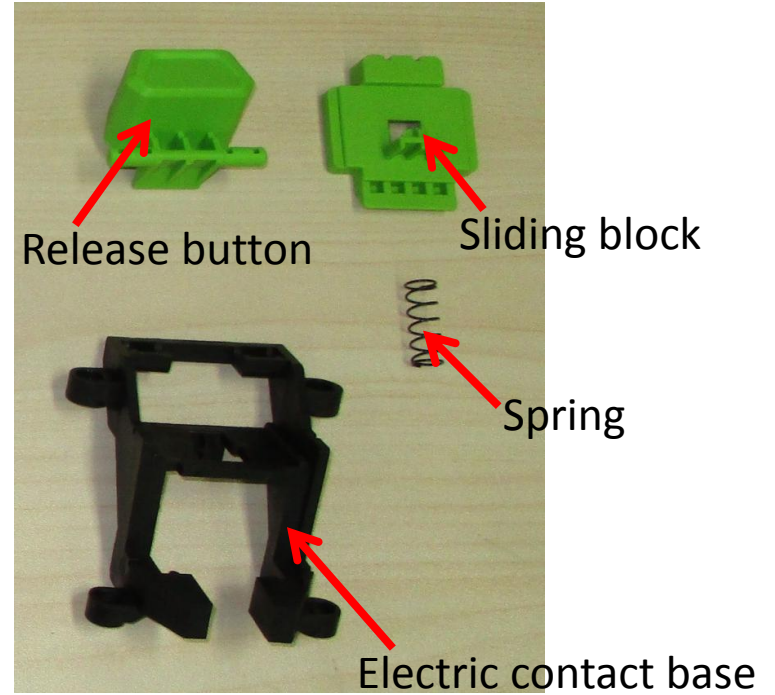
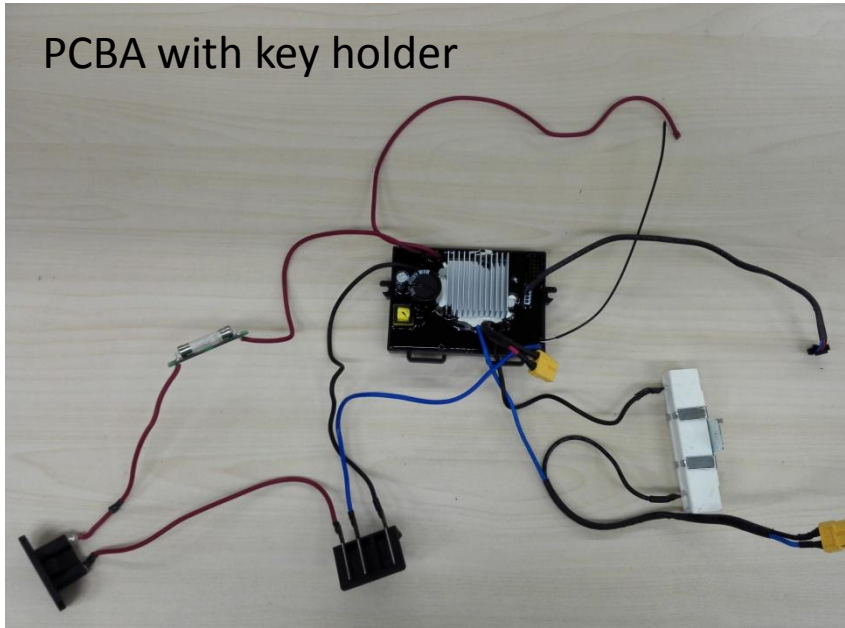

Description	Part Number	QTY	Description	Part Number	QTY
Release button	3126760001	1	Electric contact base	3126782001	1
Sliding block	3126772001	1	PCBA	2830119002	1
Spring	3660303002	1			

3. Main PCBA Replacement

12. Separate the key holder from the PCBA by using a soldering iron.
13. Replace the PCBA or key holder if they are broken or damaged.

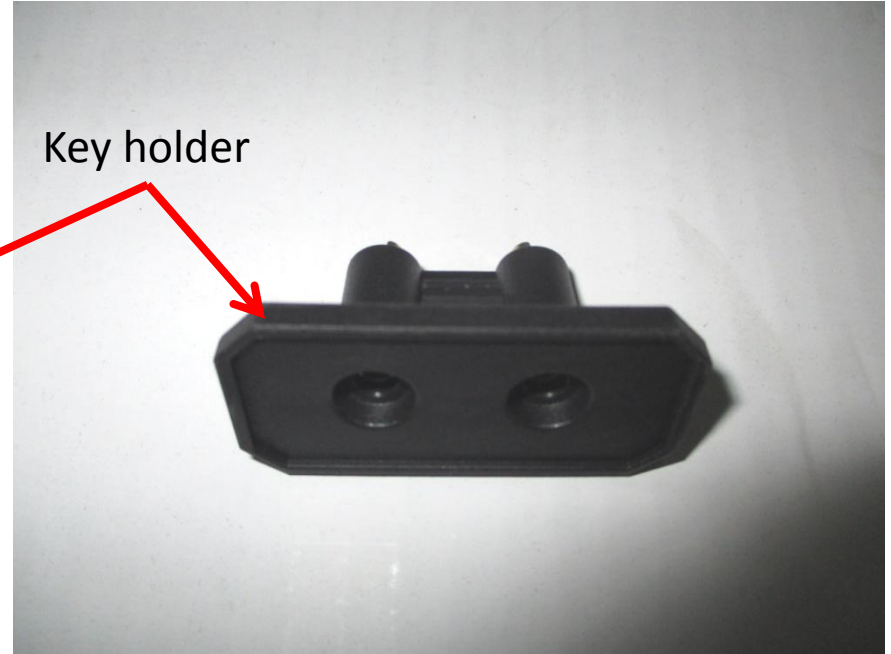
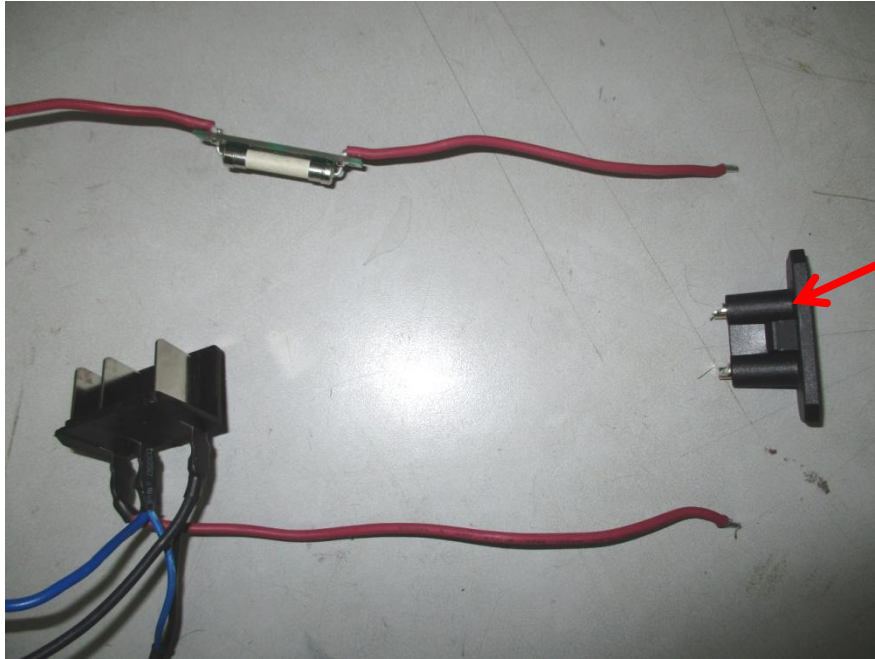

Description	Part Number	QTY
Key holder	5680195001	1

3. Main PCBA Replacement

14. Assemble the release button, sliding block and spring onto the electric contact base.

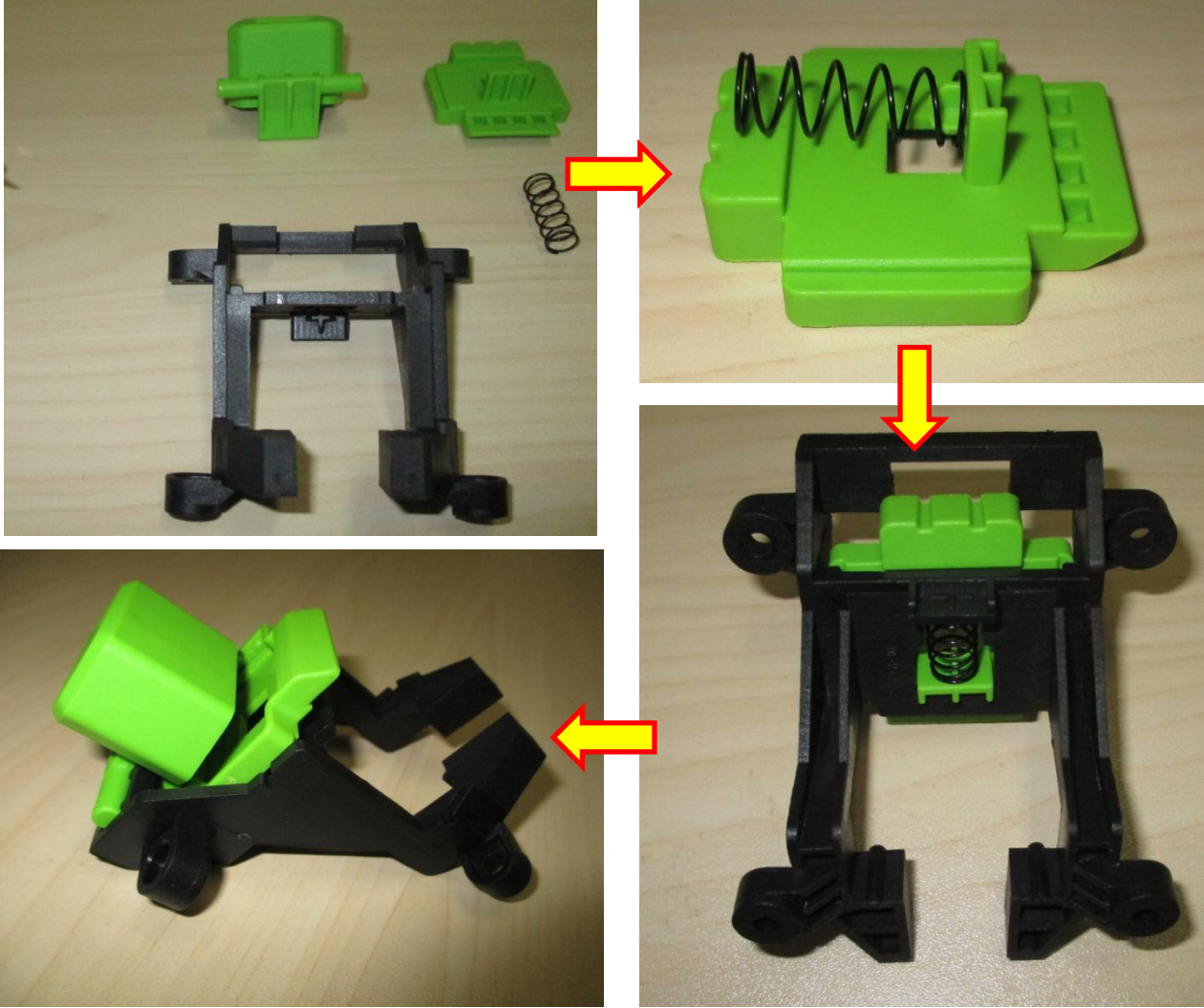

3. Main PCBA Replacement

LM2010E Lawn Mower

15. Mount the electric contact of the PCBA onto the electric contact base .

NOTICE: Hold the electrical contact base set tightly to stabilise the unit.

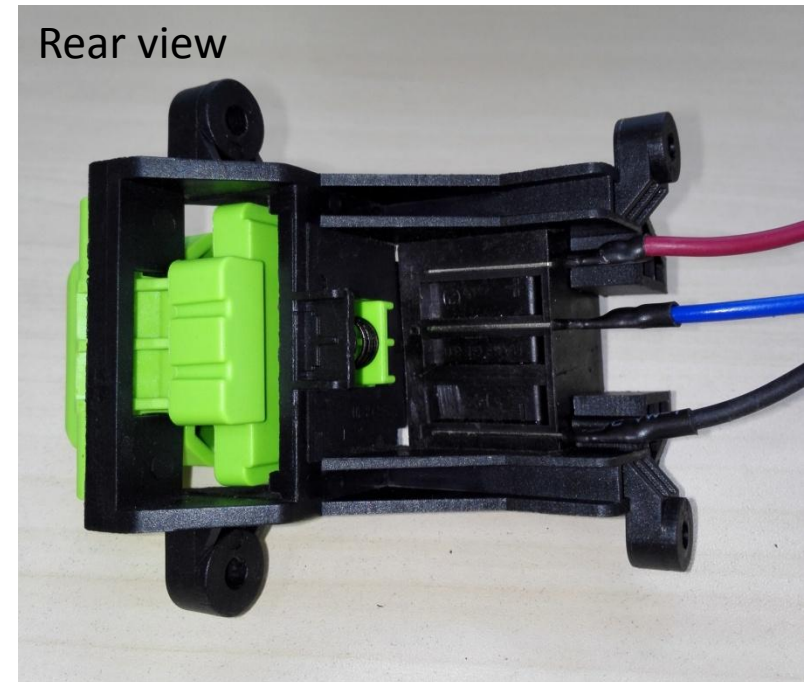
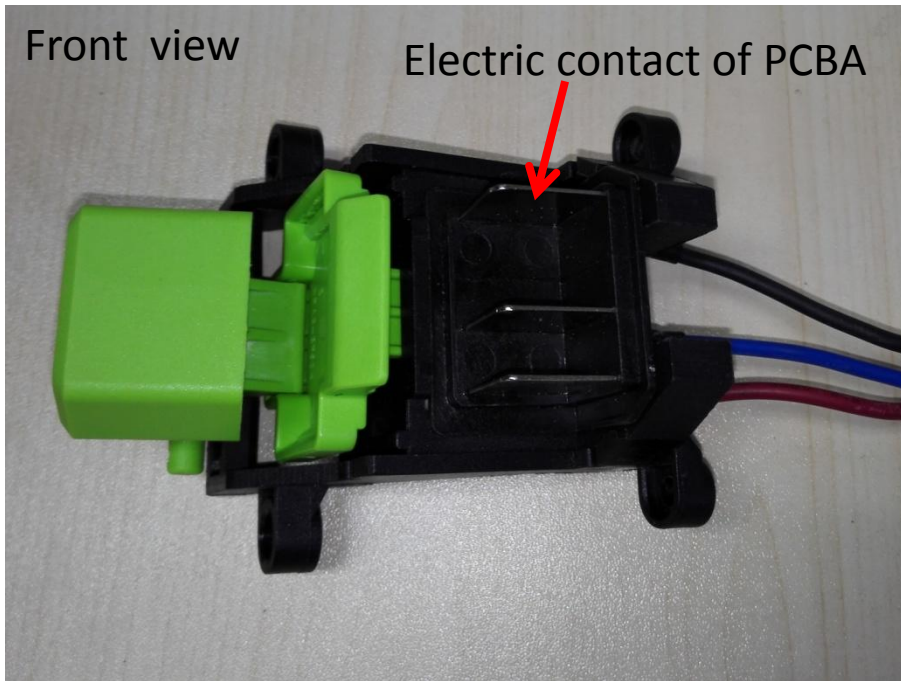

3. Main PCBA Replacement

LM2010E Lawn Mower

16. Mount them onto the battery box. Fix them by tightening the 4 screws(Fig. 1).

17. Pass the three wires through the hook on the PCBA as Fig. 2 show.

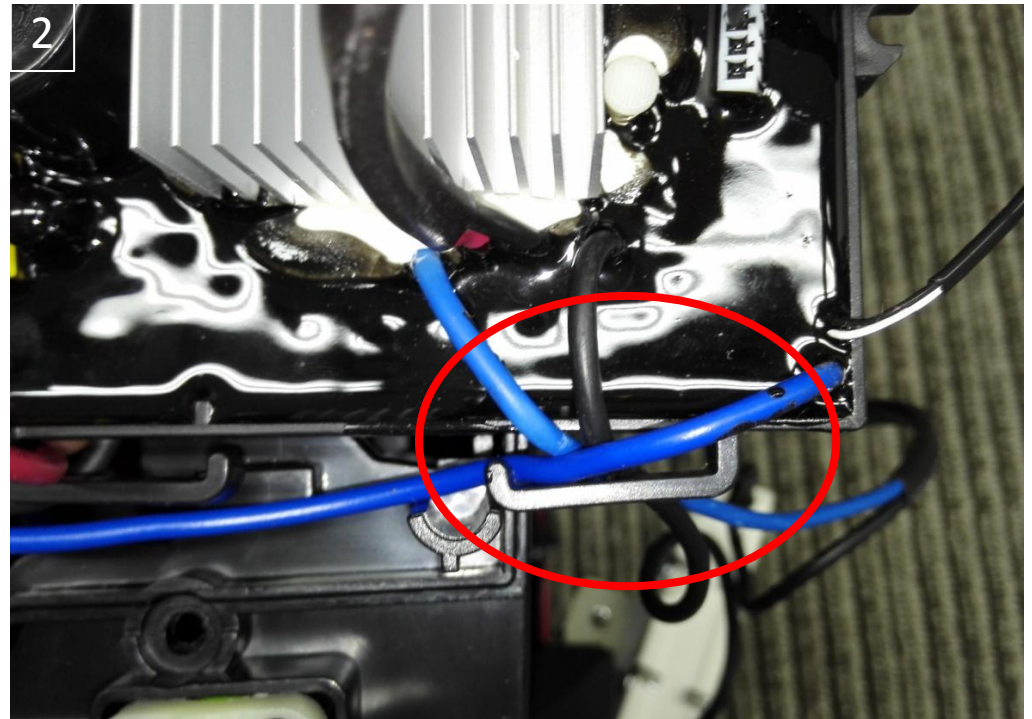
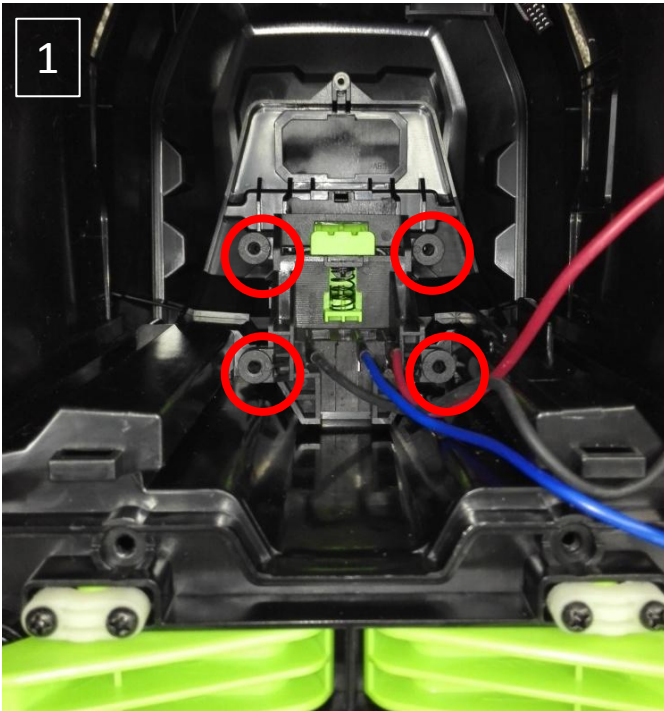

3. Main PCBA Replacement

18. Aligning the notch on the PCB board with the locating pin on the battery box, fix the PCB board by tightening the screw with the plain washer(Fig. 1). Insert the plug and align its wire into the groove.
19. From the back side, hook the blue and black wires onto the groove(Fig. 2).

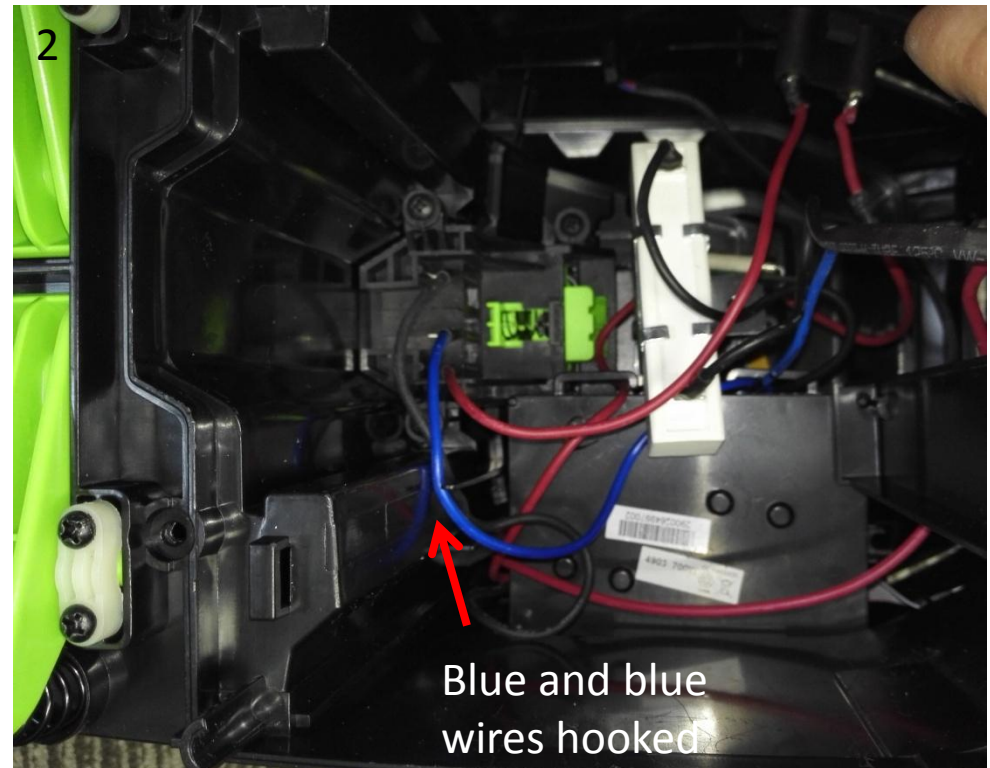
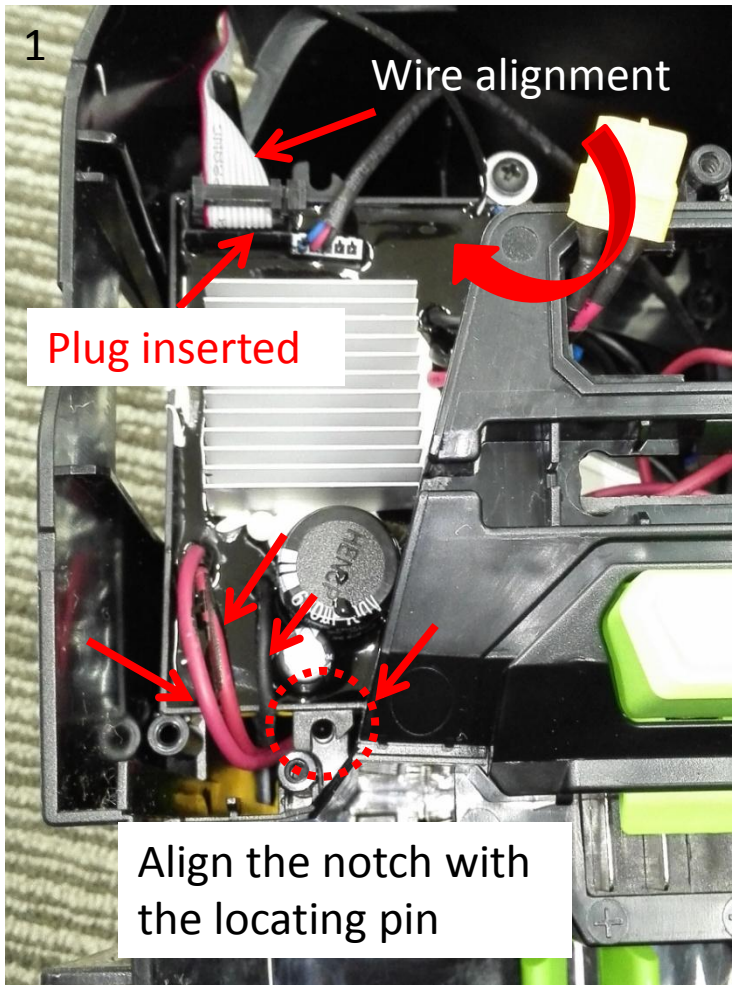

3. Main PCBA Replacement

20. Pass the two wires through the corner and hook them into the groove in the corner. The large resistor is in series with the thick black wire.

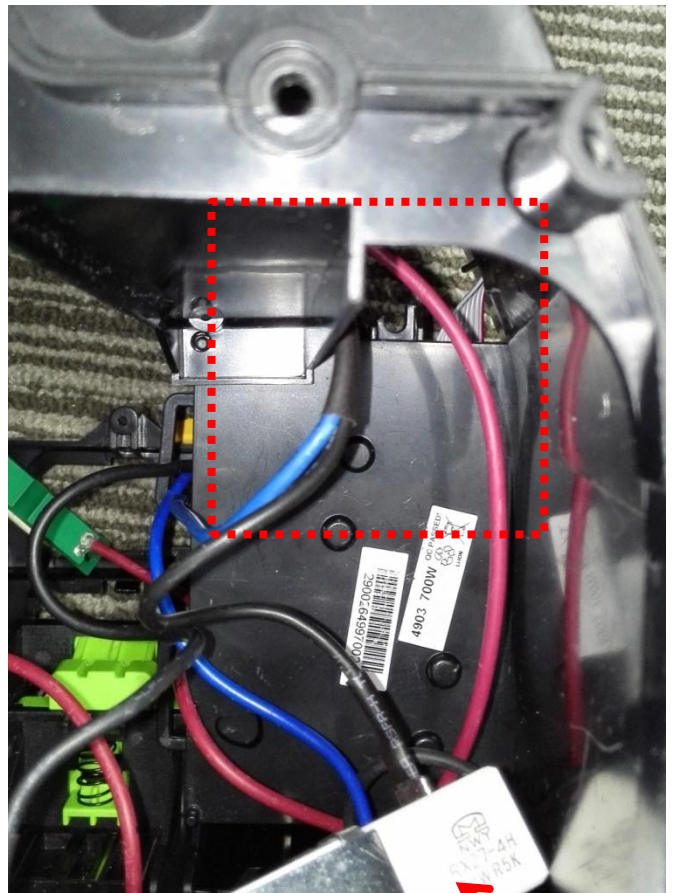

Resistor

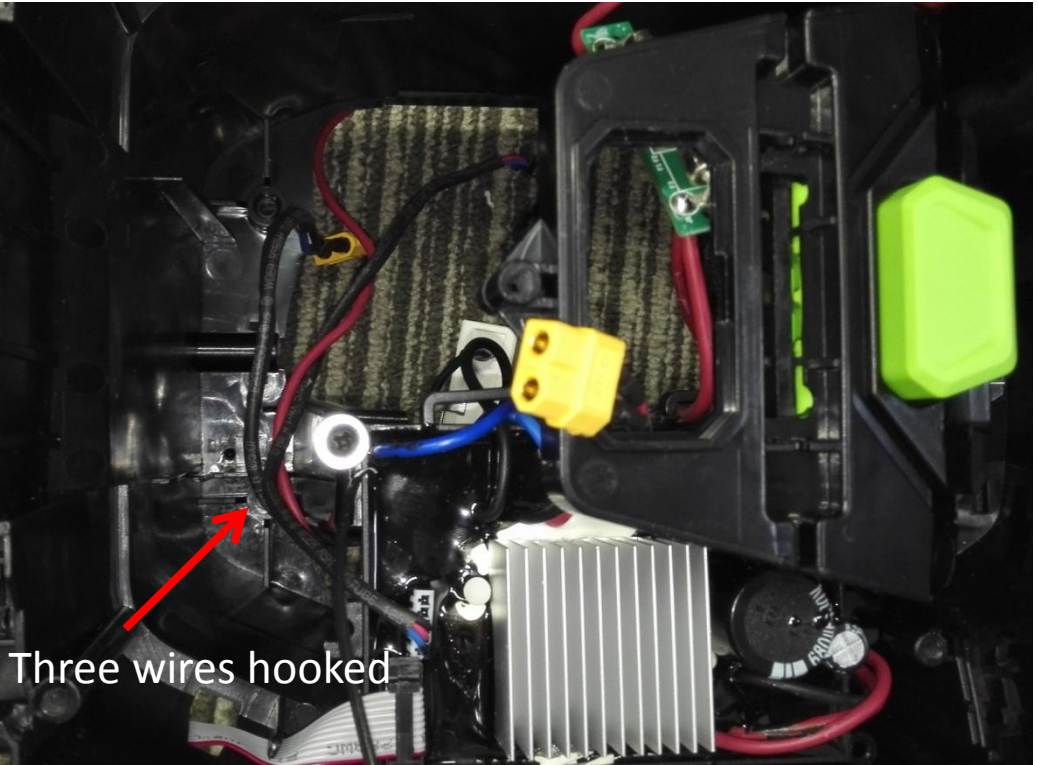

Three wires hooked

3. Main PCBA Replacement

21. Use a zip tie to fix the 3 wires.

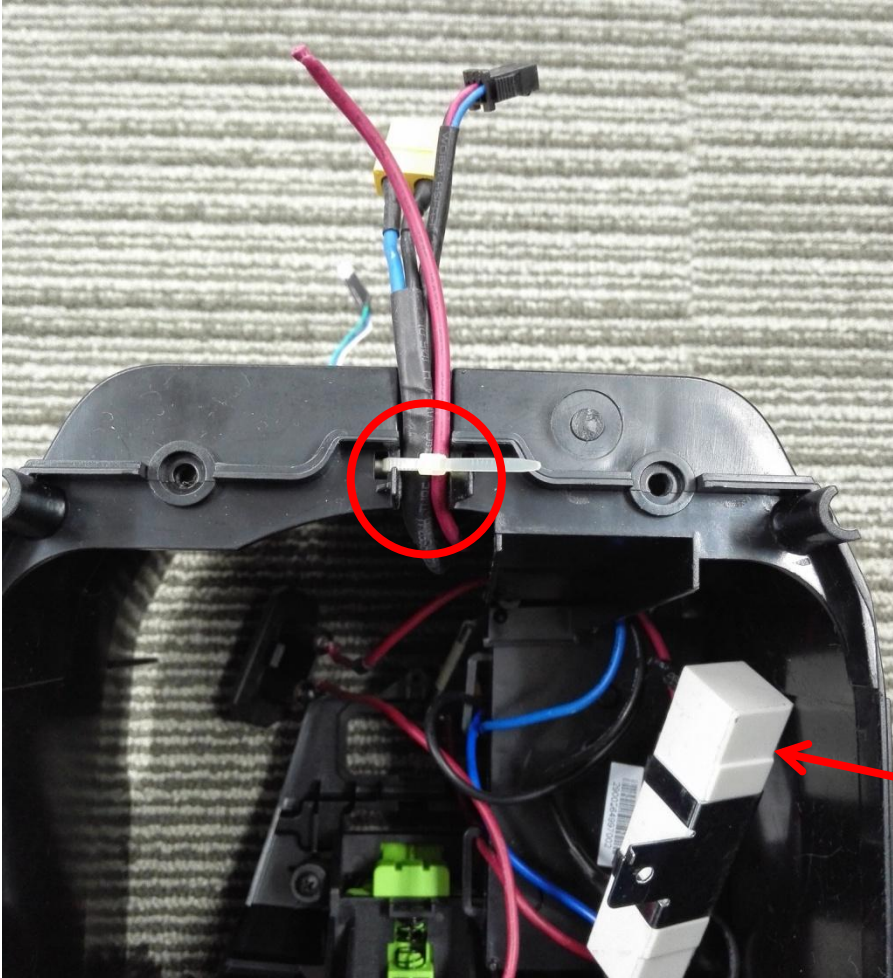

Resistor

3. Main PCBA Replacement

22. Pass the two red wires, which connect the fuse, through the other hook on the PCBA and put the longer one into the groove on the box housing(Fig. 1).
23. Reverse the battery box to pull the terminals of the two red wires as Fig. 2 show.

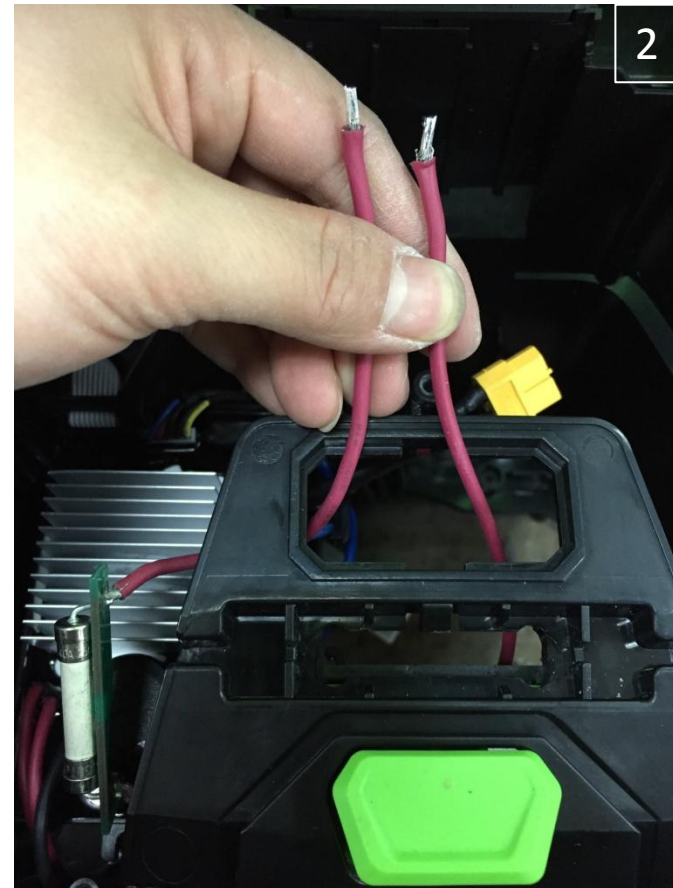
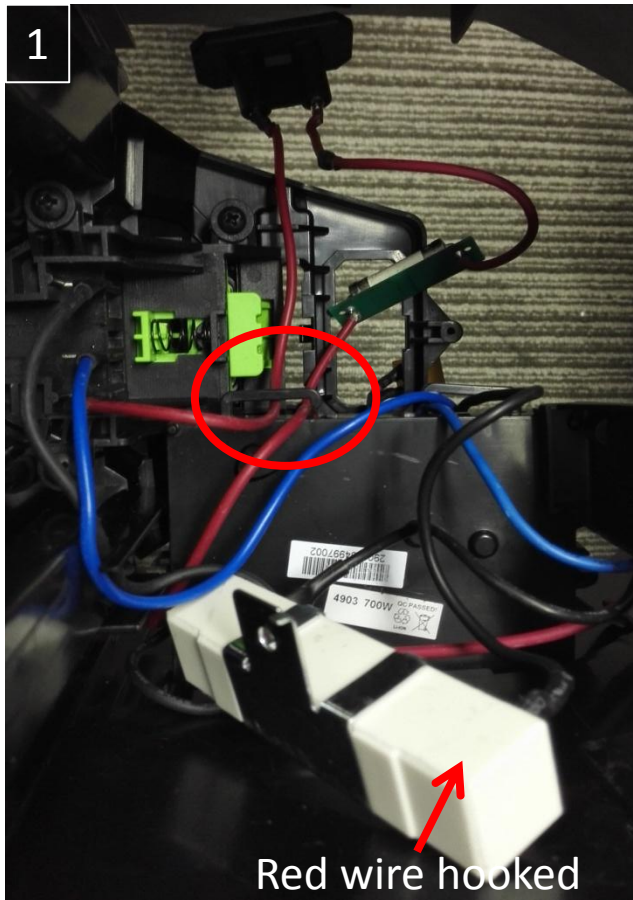

3. Main PCBA Replacement

24. Connect the key holder with the wires by soldering as following steps show.

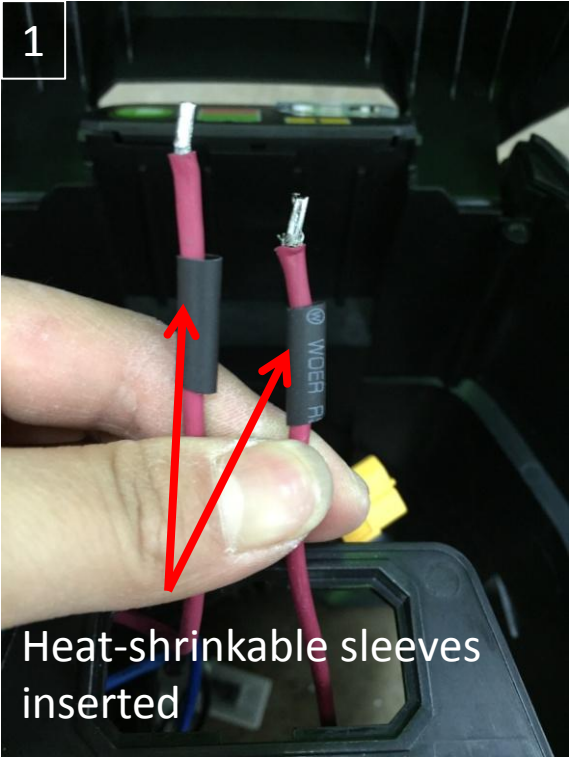

3. Main PCBA Replacement

LM2010E Lawn Mower

25. Put the key holder in place and align the fuse with its wire into the groove. The fuse should be facing downwards.

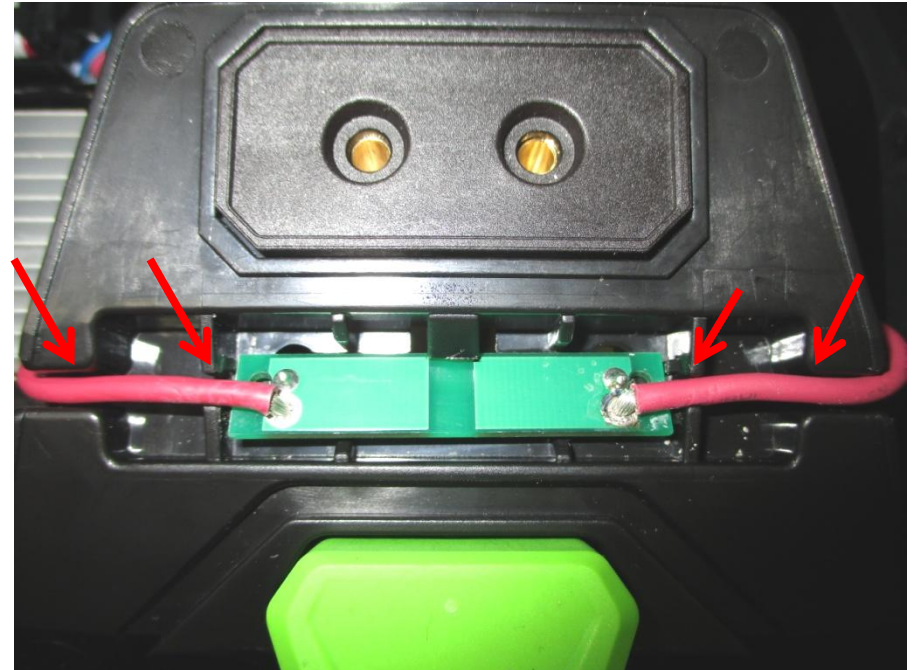
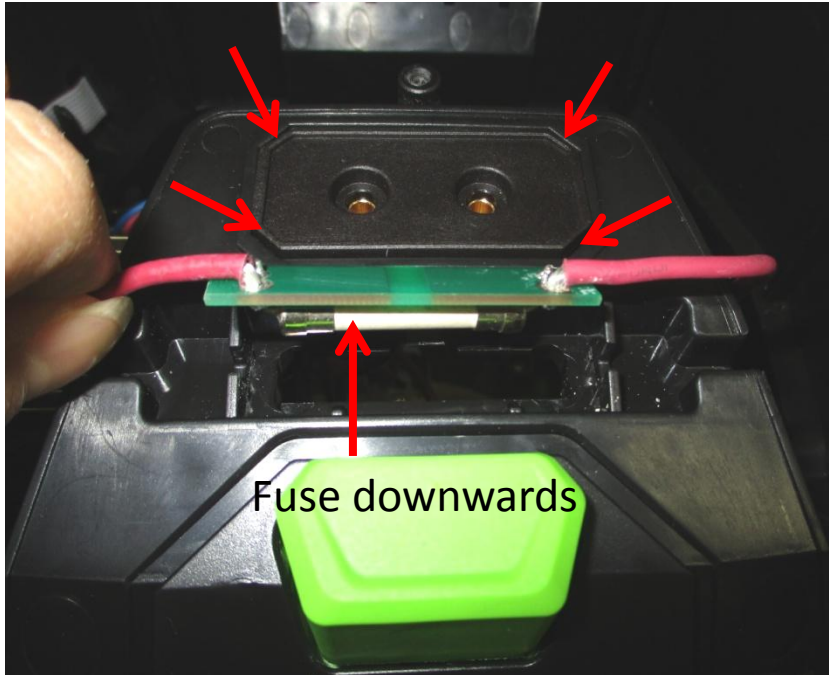

3. Main PCBA Replacement

LM2010E Lawn Mower

26. Mount the motor into the battery box as “Motor Assembly Replacement” part show.
27. Close the inner cover by locking the 5 screws.

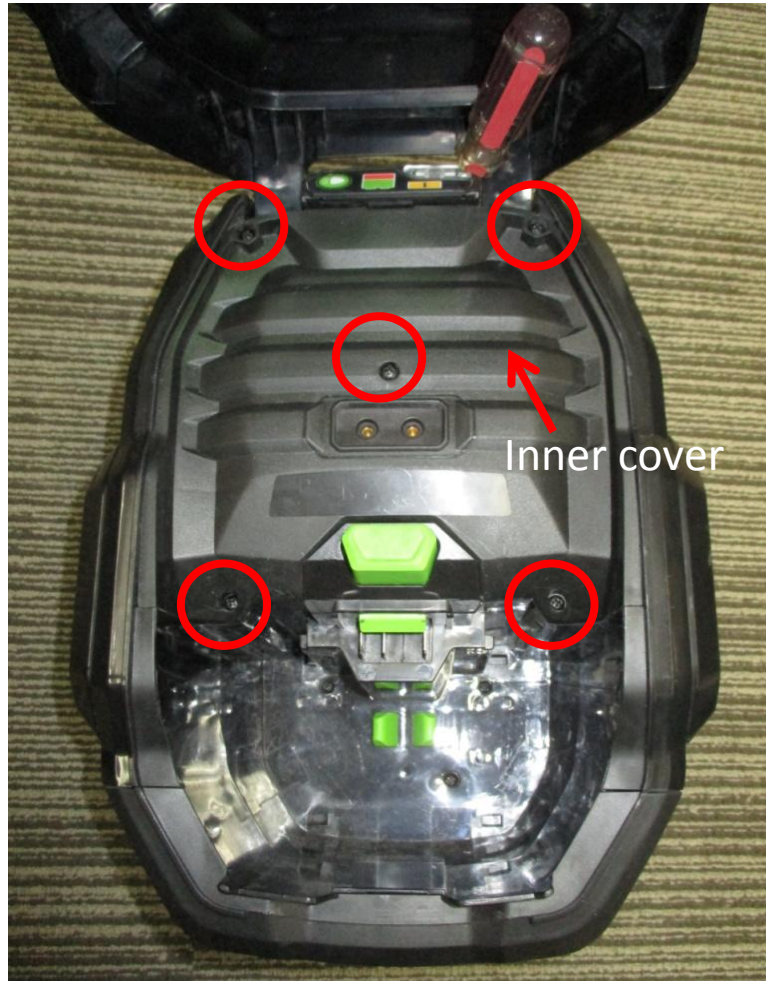

4. Power Unit Assembly

- 1. Mount the reassembled power unit onto the mower. 5pcs of wires should be exposed.

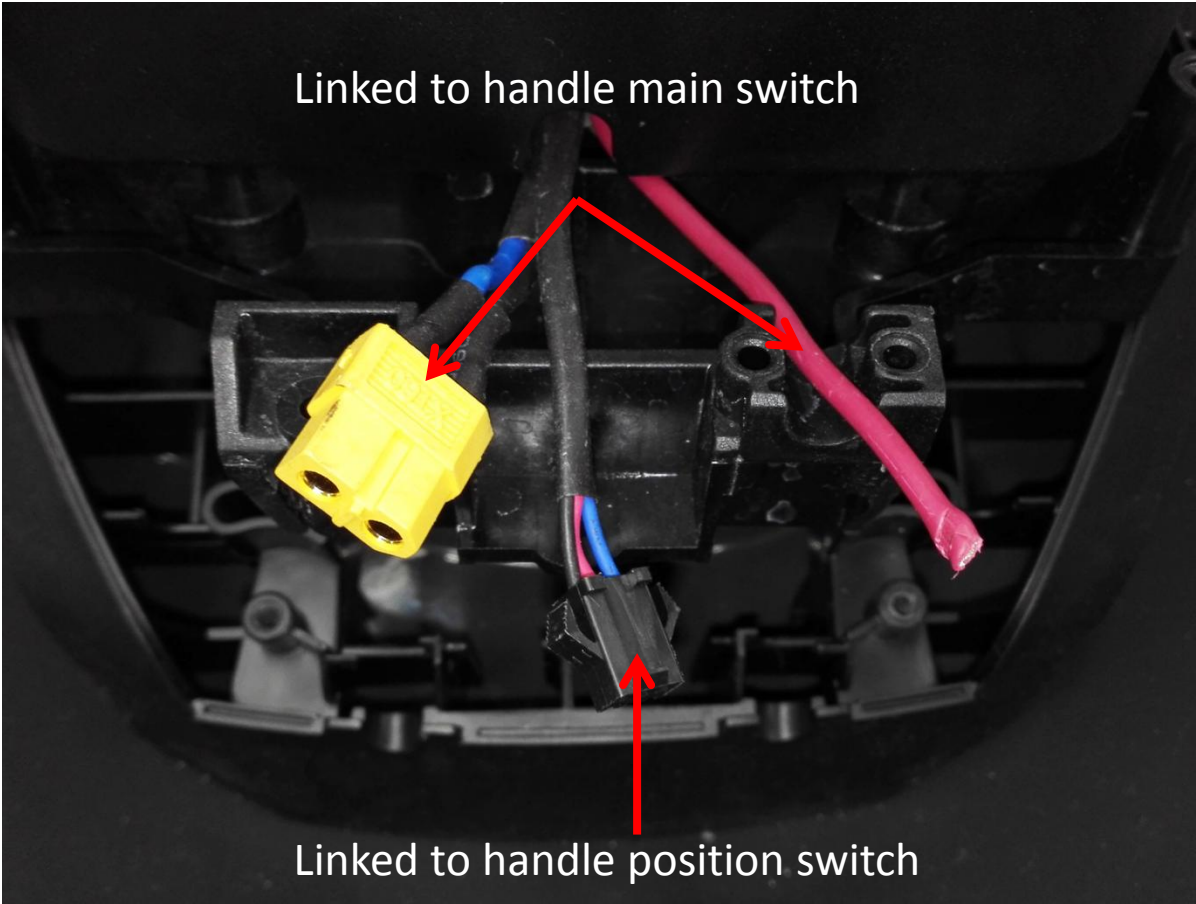

4. Power Unit Assembly

2. Soldering the red wires as following steps show.

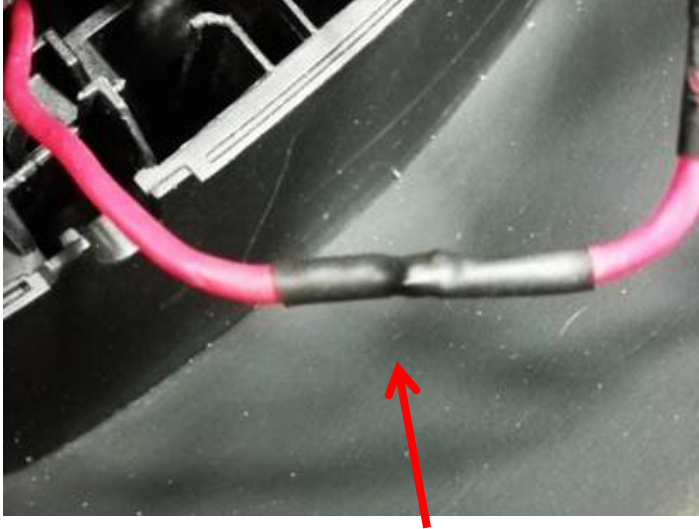
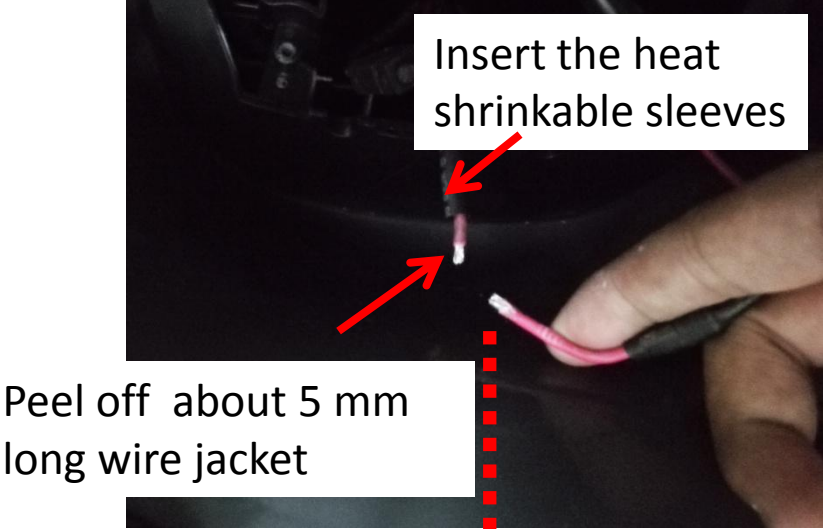

4. Power Unit Assembly

- 3. Insert the plugs into the corresponding sockets and pay attention to the installation position of each wire.

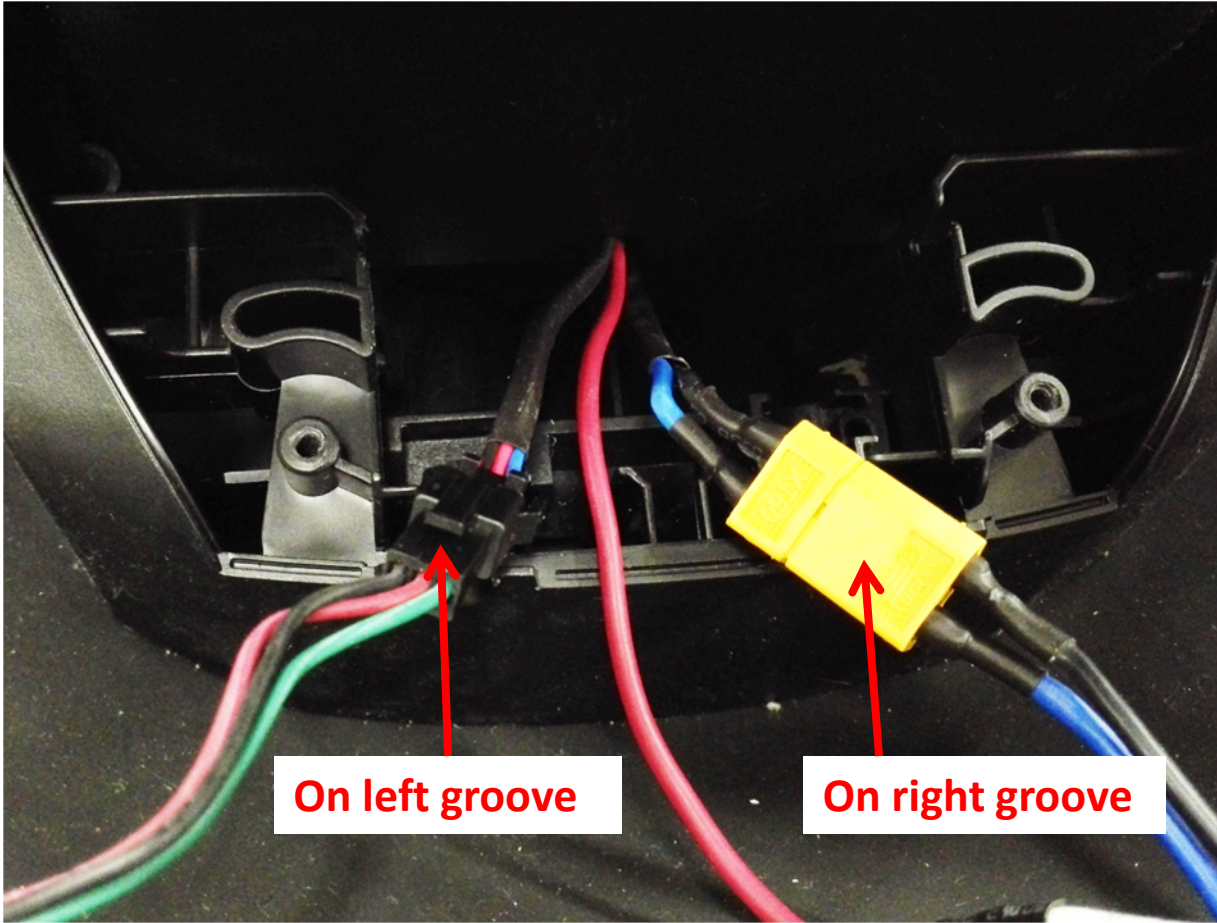

4. Power Unit Assembly

4. Align the wires into the grooves.

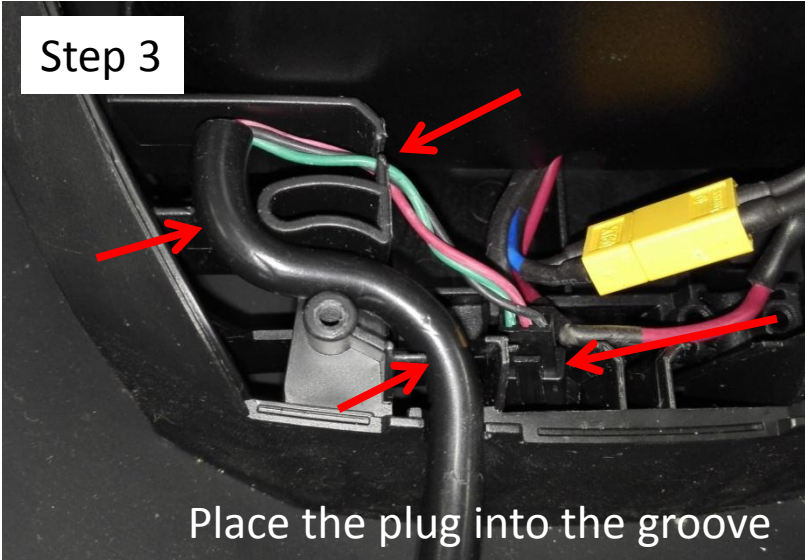
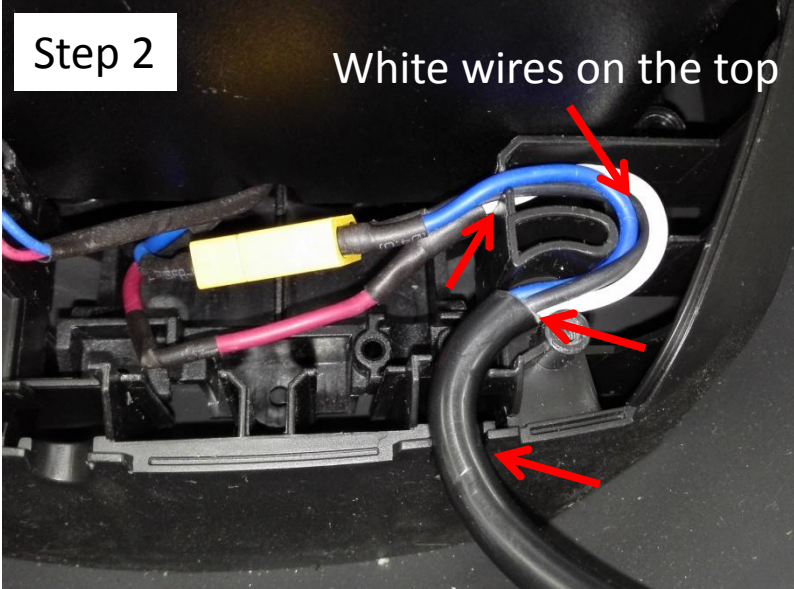
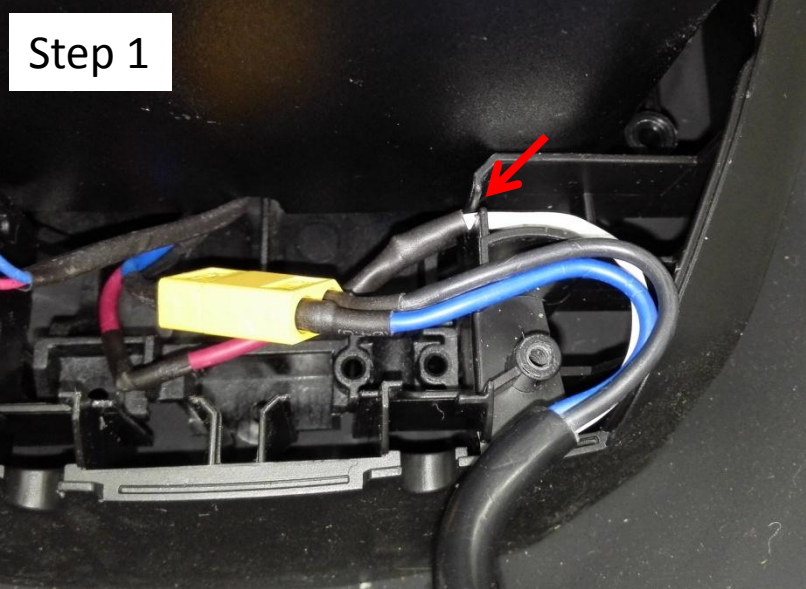

4. Power Unit Assembly

- 5. Turn the mower on its back. In this way, the power unit can be located stably on the mower without dropping.
- 6. Tighten the 4 hexagon head bolts with a socket wrench(S=10mm) to fix the power unit.

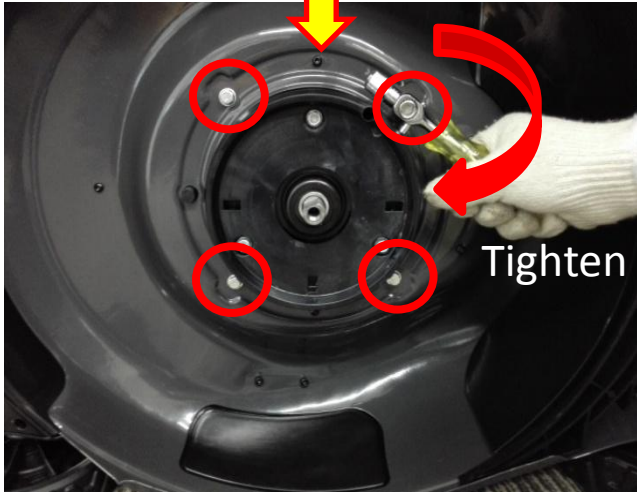

4. Power Unit Assembly

7. Close the service cover.

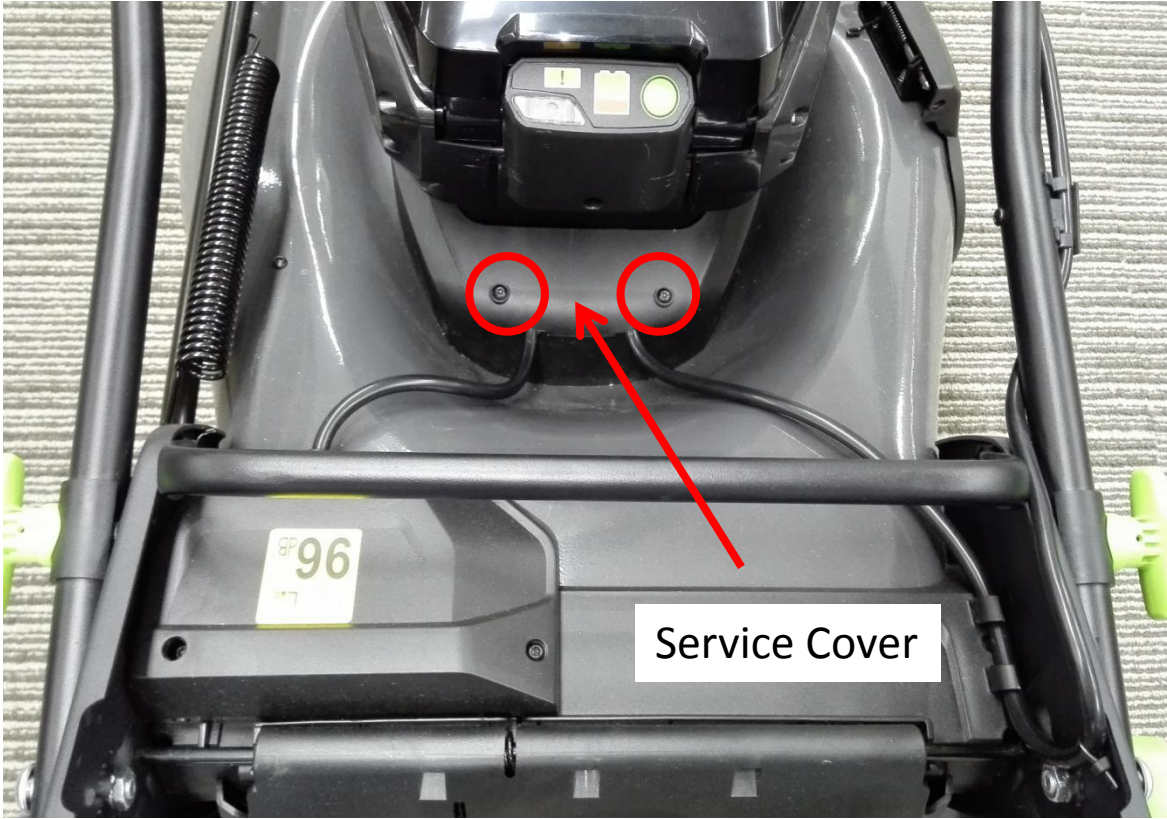

THE END

REPAIR GUIDELINE

PART 3.2: LED Light Assembly Replacement_LM2010E Lawn Mower



Table of Contents

LM2010E Lawn Mower

NO.	Contents	Page
1	LED Film Switch Replacement	3
2	LED Headlights Replacement	4-12

1. LED Film Switch Replacement

LM2010E Lawn Mower

The LED Film switch button can be replaced following the figures show below.

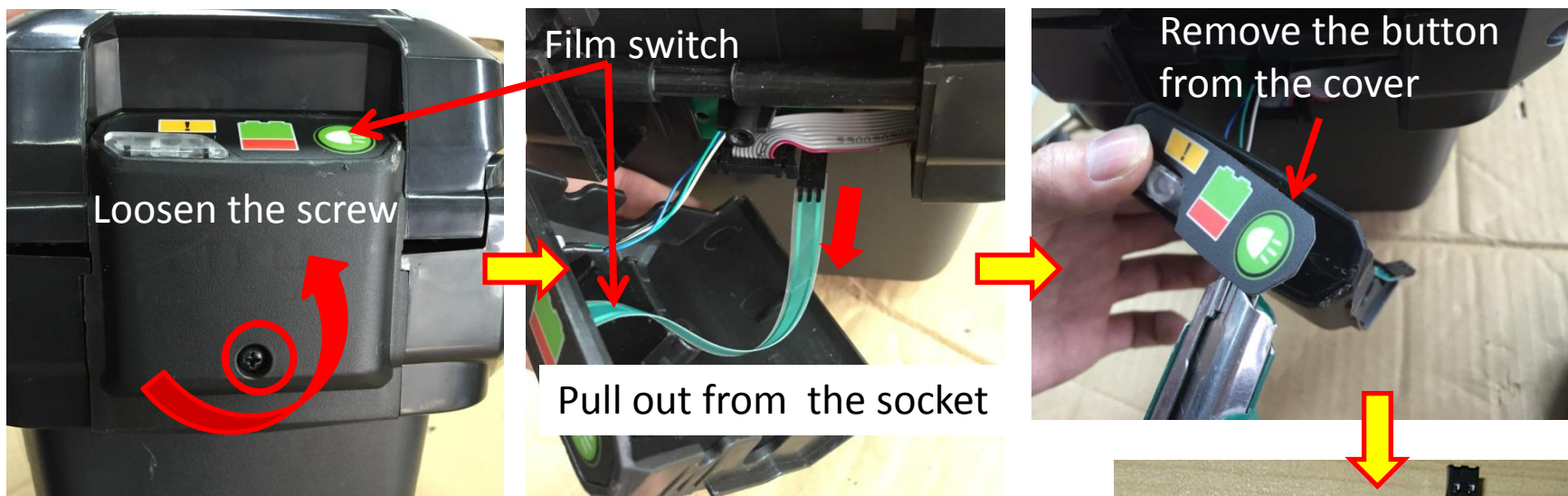

Description	Part Number	SPEC	Qty
Film switch button	4870558001	-	1
Tapping screw	5610042014	4.2×19	1



2. LED Headlights Replacement

LM2010E Lawn Mower

1. Remove the cover of the LED Film switch button as previous steps show.
2. Pull the power indicator LED out from the cover (Fig. 1).
3. Separate the wiring harness from its socket(Fig. 2).
4. Remove the battery inner cover from the battery box(Fig. 3).

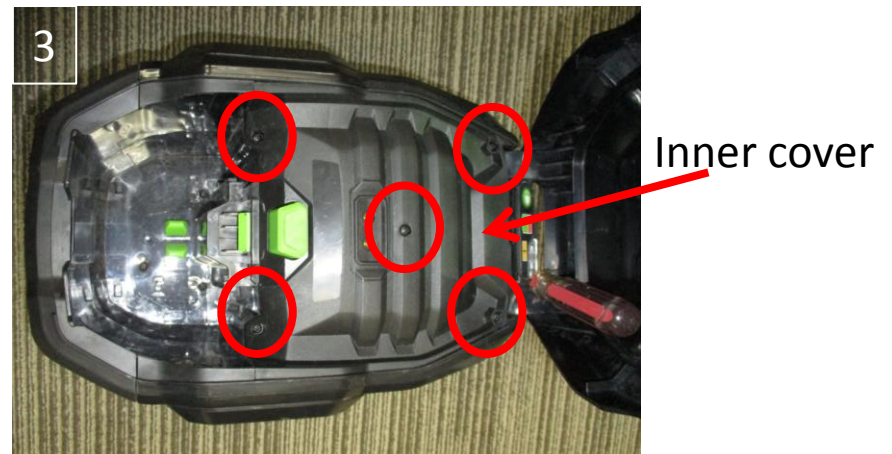
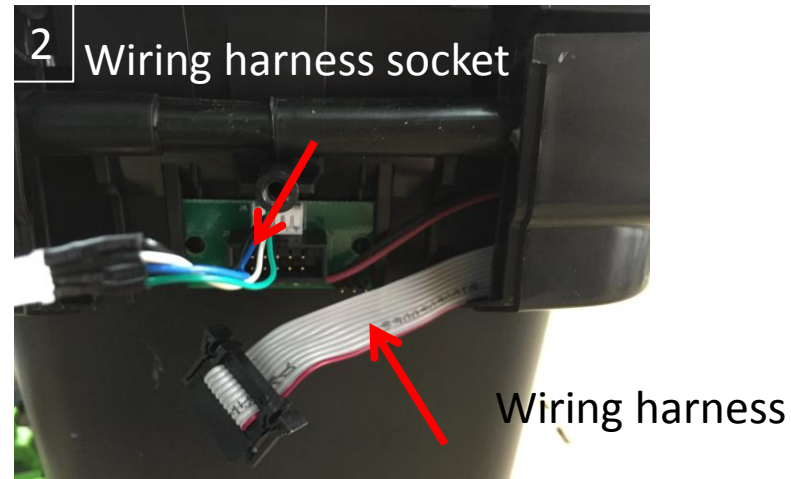
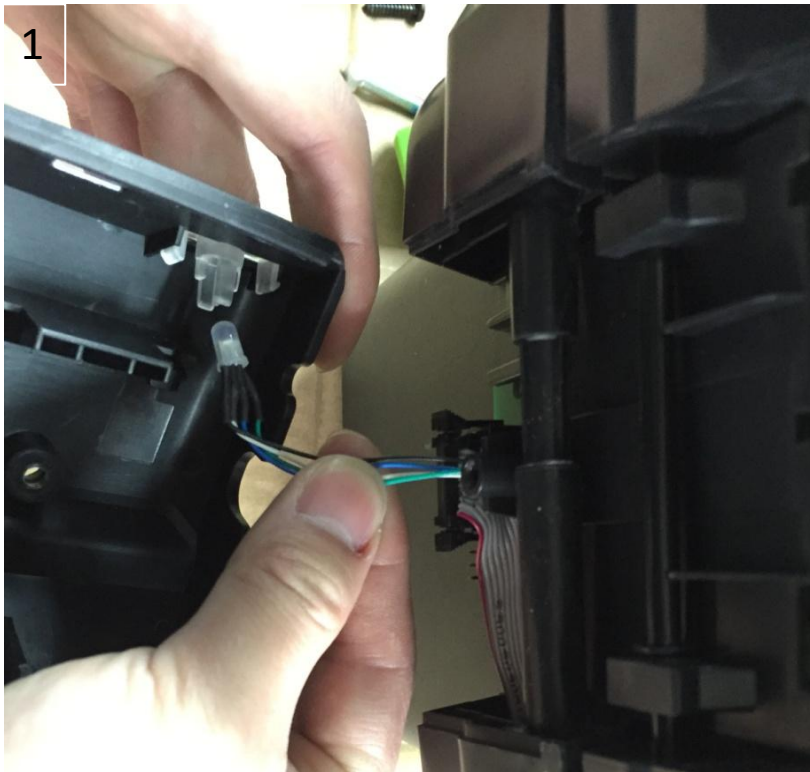

2. LED Headlights Replacement

LM2010E Lawn Mower

5. Fold the handle to the operating position and remove the screw on the right (red circle indication) to separate the coupled decorative covers.
6. Prize open the left and right decorative covers using two screwdrivers. If the decorative covers are damaged, replace them.

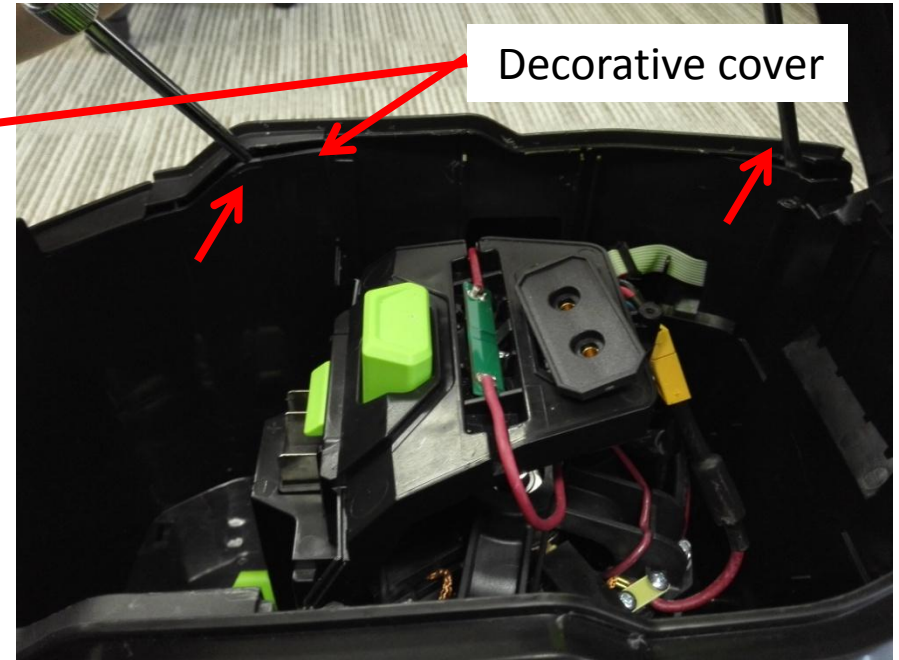

Description	Part Number
Right decorative cover	3127898001
Left decorative cover	3127899001

2. LED Headlights Replacement



Decorative covers

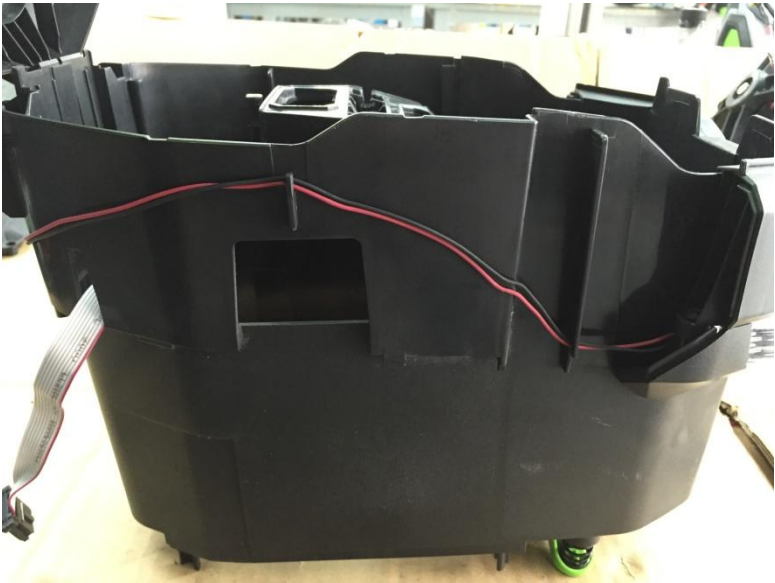

2. LED Headlights Replacement

LM2010E Lawn Mower

7. Remove the 2 screws to separate the front decorative cover.

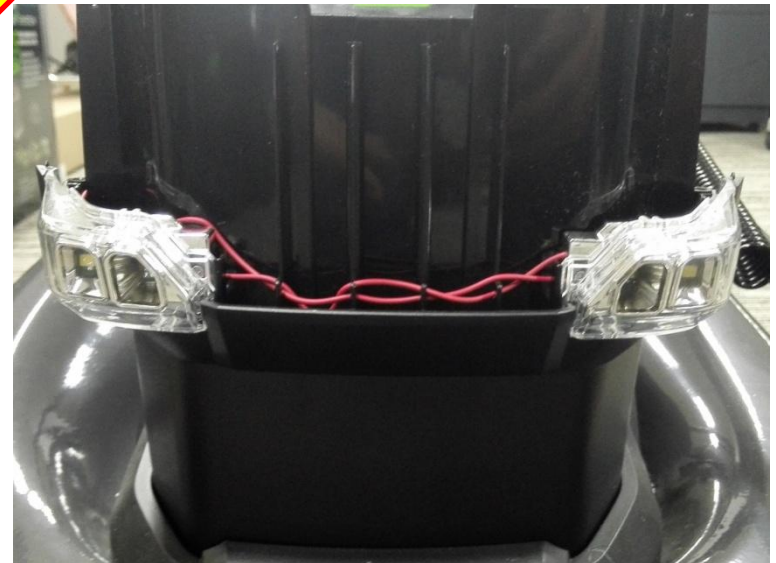
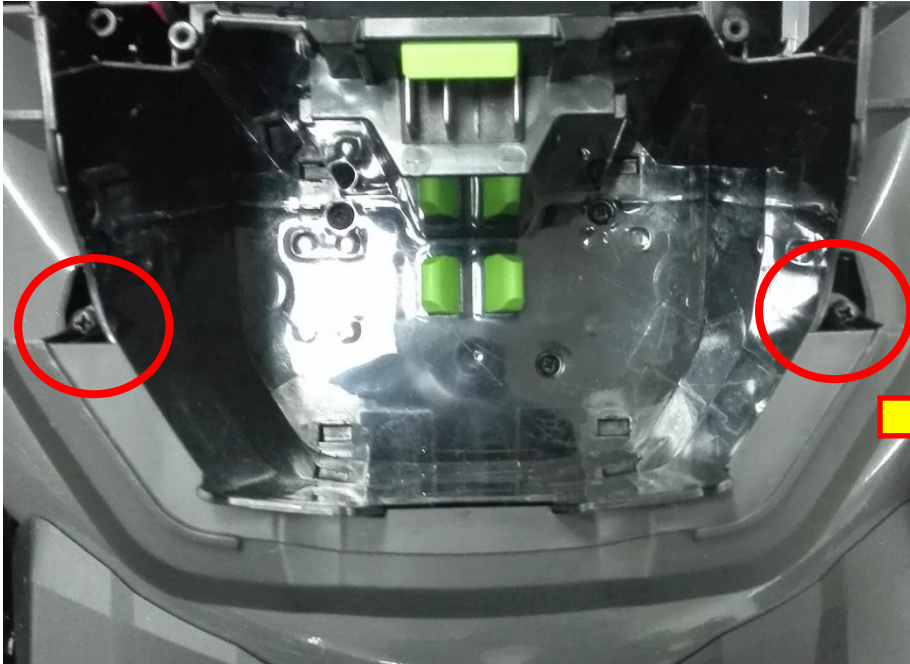

Description	Part Number	SPEC	Qty
Tapping screw	5610042014	4.2×19	2

2. LED Headlights Replacement

LM2010E Lawn Mower

8. Remove the LED headlights from the battery box.

The LED headlights includes 3 small PCBs, two reflectors and two transparent caps.

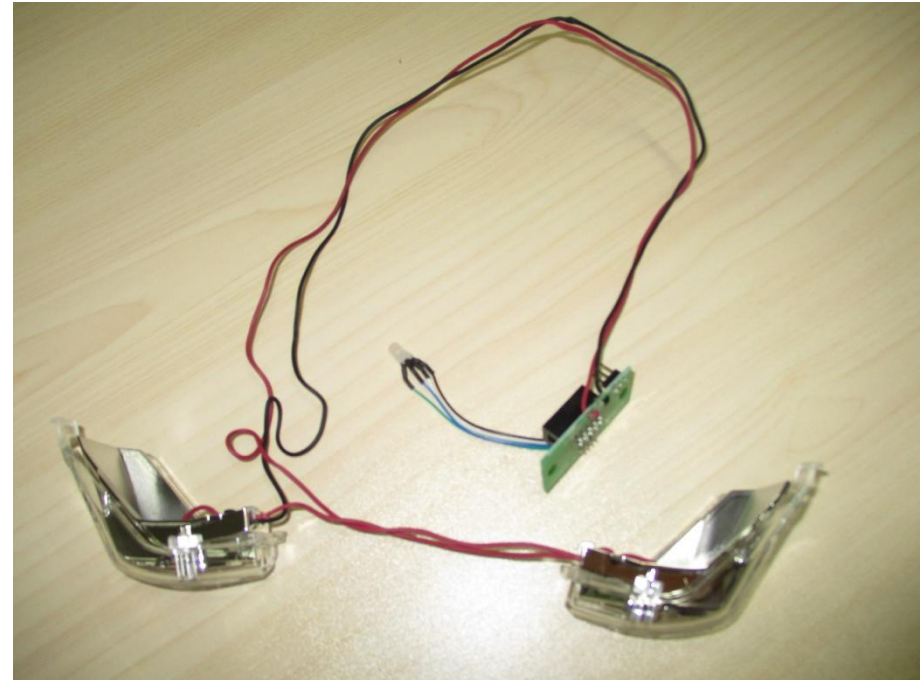
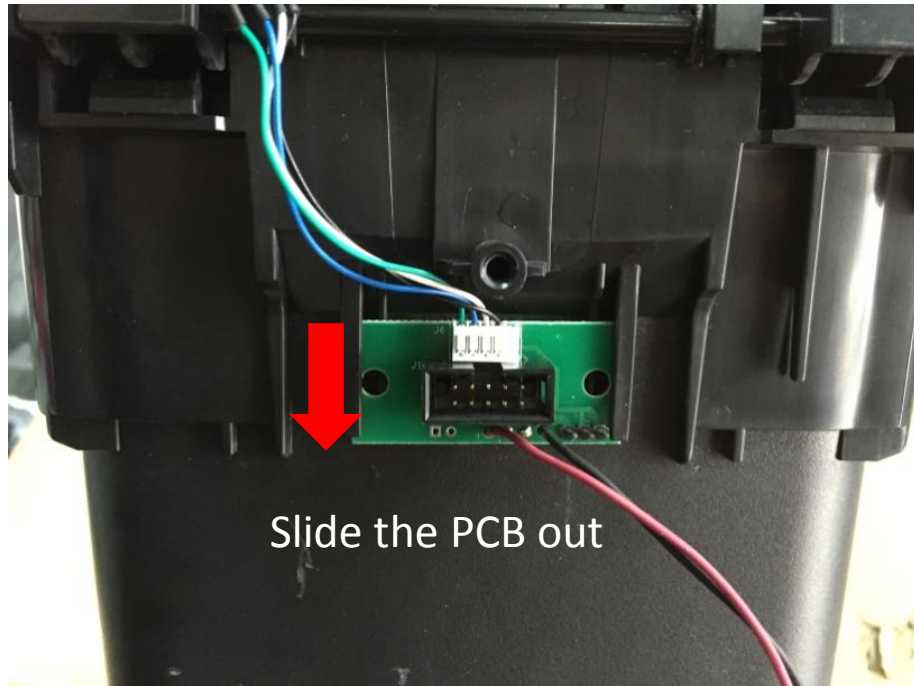

2. LED Headlights Replacement

LM2010E Lawn Mower

9. Replace the broken parts included in the LED headlights. If the front decorative cover or EGO logo is broken too, replace them.

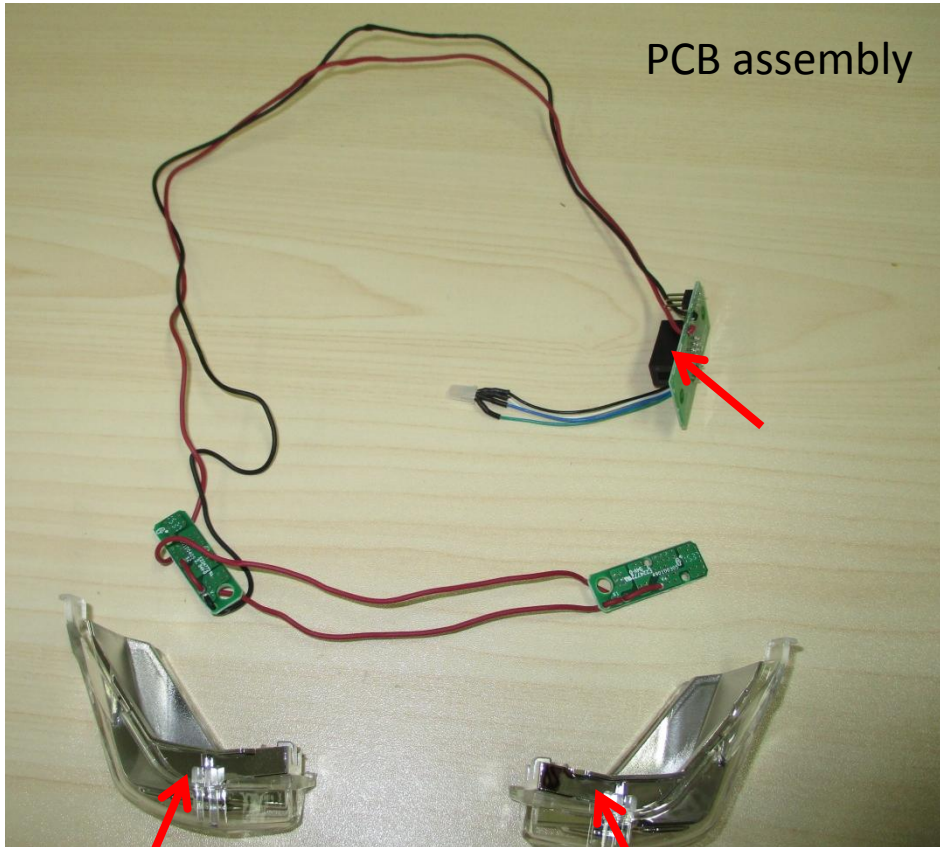

Right transparent cap with reflector

Left transparent cap with reflector



Front decorative cover

EGO logo

Description	Part Number
PCB assembly	2823604003
Right transparent cap	3127981001
Left transparent cap	3127982001
Right reflector	3127983001
Left reflector	3127984001
Front decorative cover	3127889002
EGO logo	3321927001

2. LED Headlights Replacement

10. Assemble the new LED headlights onto the battery box.

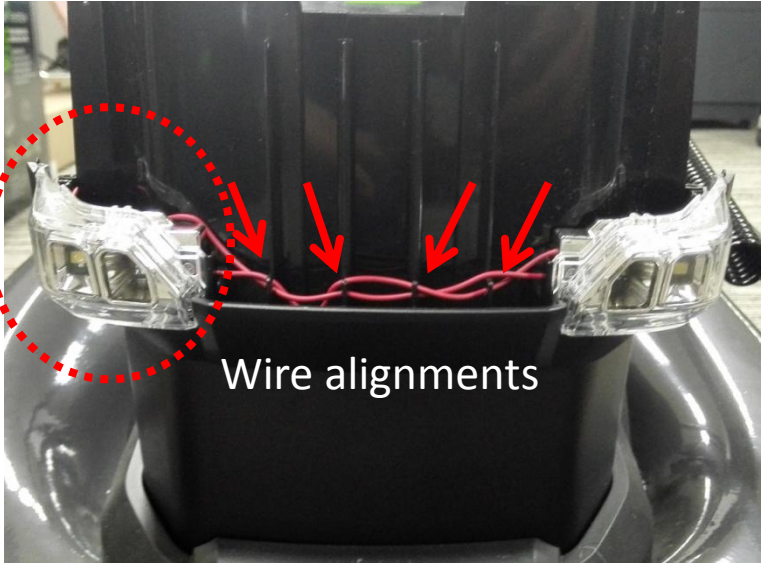
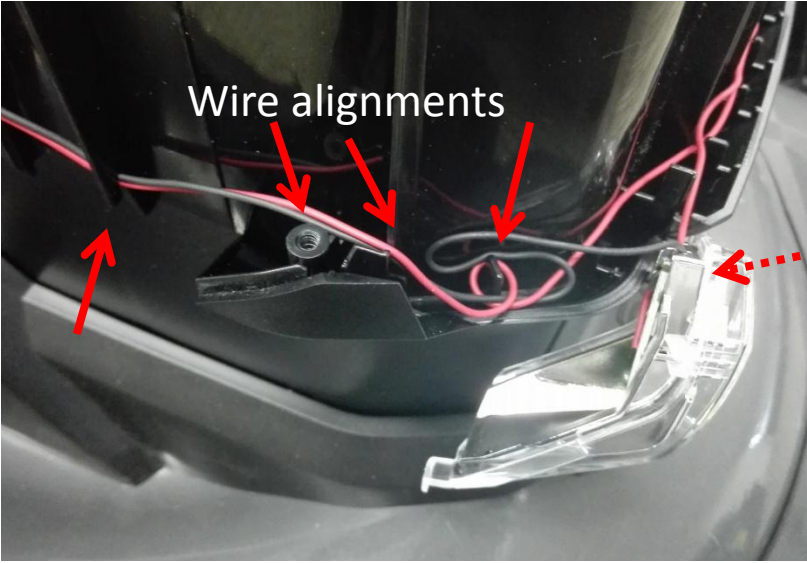

2. LED Headlights Replacement

11. Align the wires into the groove as well as the PCB.

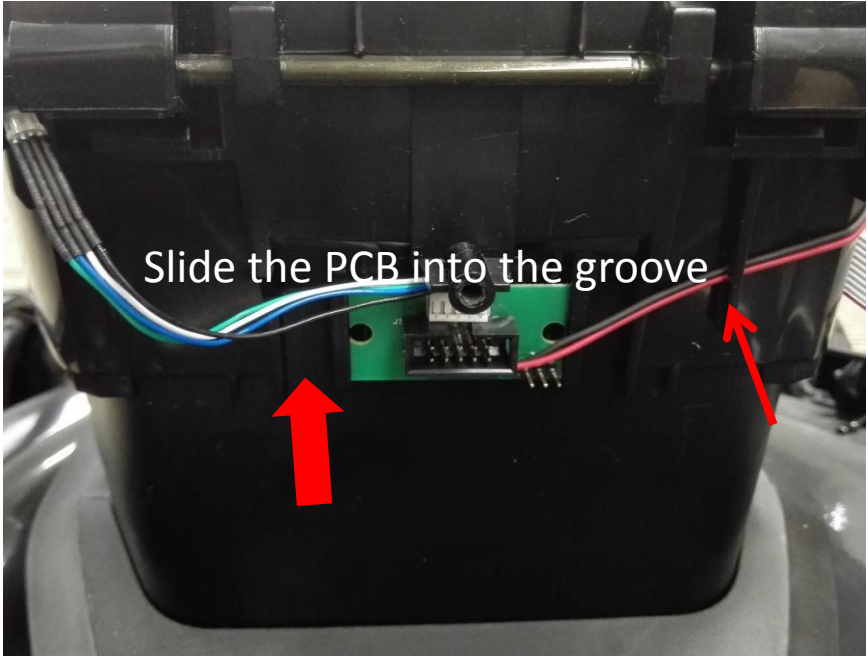
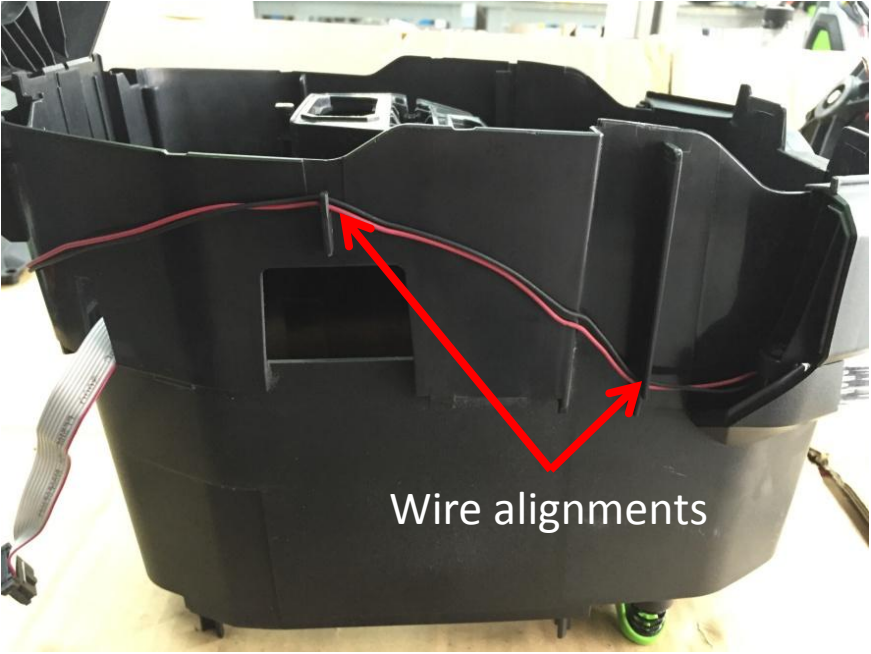

2. LED Headlights Replacement

LM2010E Lawn Mower

12. Plug the wire harness into its socket(Fig. 1).

13. Mount the decorative covers onto the battery box and lock them with the screw (Fig. 2).

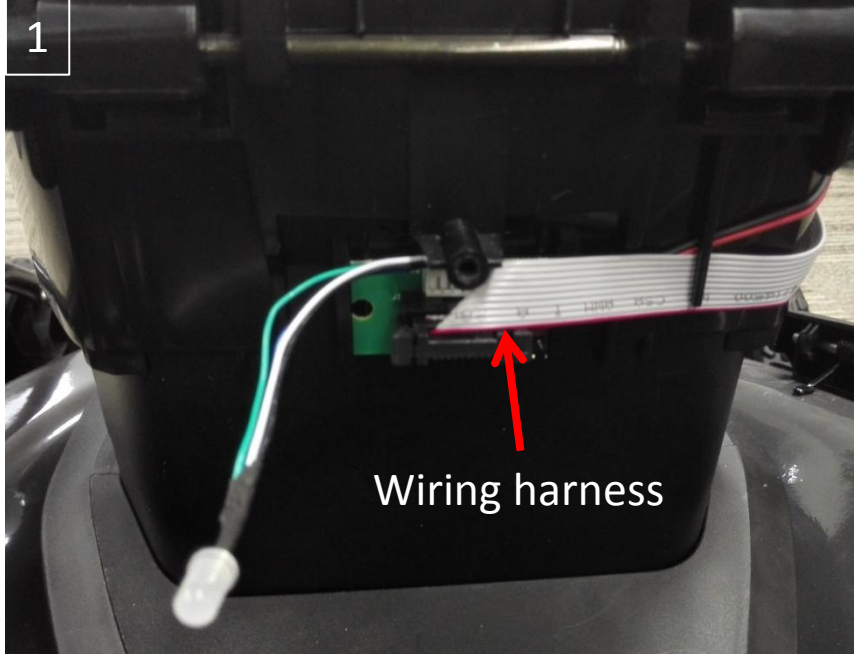

14. Mount the LED film switch button in reverse order.

THE END

REPAIR GUIDELINE

PART 3.3: Battery Cover Assembly Replacement_LM2010E Lawn Mower



Battery Cover Assembly Replacement

LM2010E Lawn Mower

The battery cover consists of the transparent guard and the battery cover.



Description	Part Number
Battery cover	3127880001
Transparent guard	3127900001
Shaft	5670380001
E-clip	5660003003

Battery Cover Assembly Replacement

LM2010E Lawn Mower

1. Remove the screw to open the LED film switch button cover.
2. Remove the E-clip from the shaft.

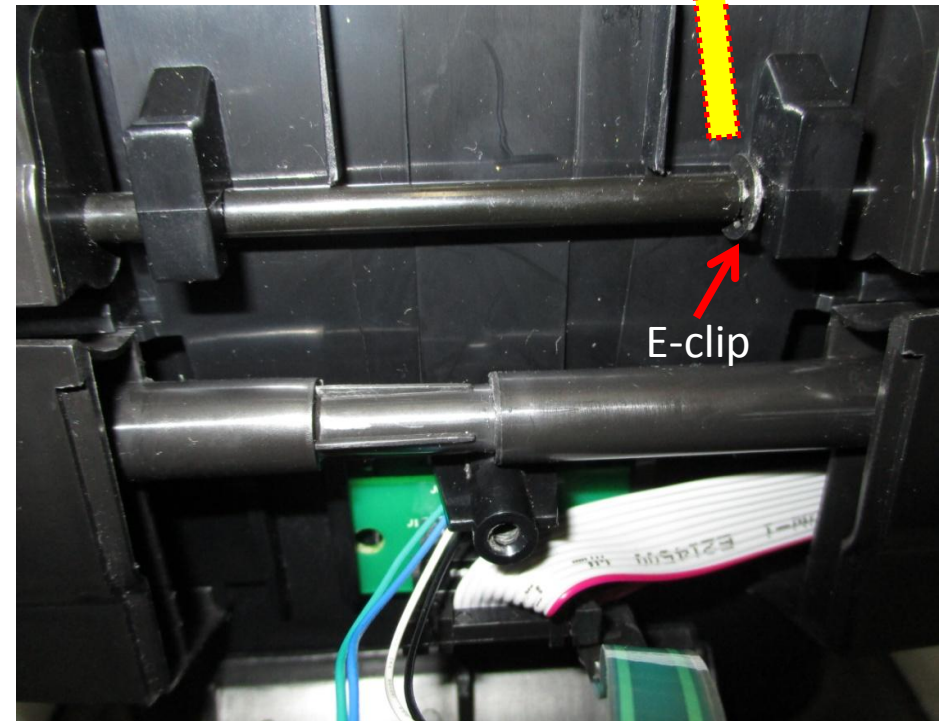
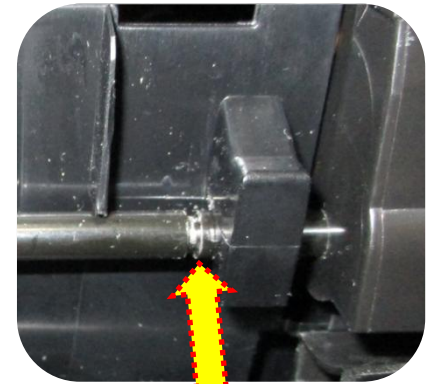

Battery Cover Assembly Replacement

LM2010E Lawn Mower

3. Draw the shaft out from the battery cover assembly using a certain thin rod.
4. Replace with a new battery cover assembly; Fix the new one onto the battery box in reverse order.

Eject the shaft
on the left with
a thin rod



Draw out the shaft
from the right

Shaft

THE END

REPAIR GUIDELINE

PART 4: Rear Cover Replacement_LM2010E Lawn Mower



Rear Cover Replacement

LM2010E Lawn Mower



Rear Cover

Description	Part Number
Rear Cover	3127944001

Rear Cover Replacement

LM2010E Lawn Mower

1. Remove the E-clip from the shaft using a flat head screwdriver.



Rear Cover Replacement

LM2010E Lawn Mower

2. Pull out the shaft from left side by hand (Fig. 1).
3. Take down the rear cover and shaft (Fig. 2).



Description	Part Number	SPEC
Shaft	5670382001	Φ11x 365
E-clip	5660139002	

Rear Cover Replacement

LM2010E Lawn Mower

4. Remove the spring from the rear cover.
5. Replace with a new rear cover or torsion spring.



Description	Part Number	SPEC
Torsion Spring	3660559001	Φ15.2x25

Rear Cover Replacement

LM2010E Lawn Mower

6. Insert the shorter foot of the torsion spring into the groove of rear cover.

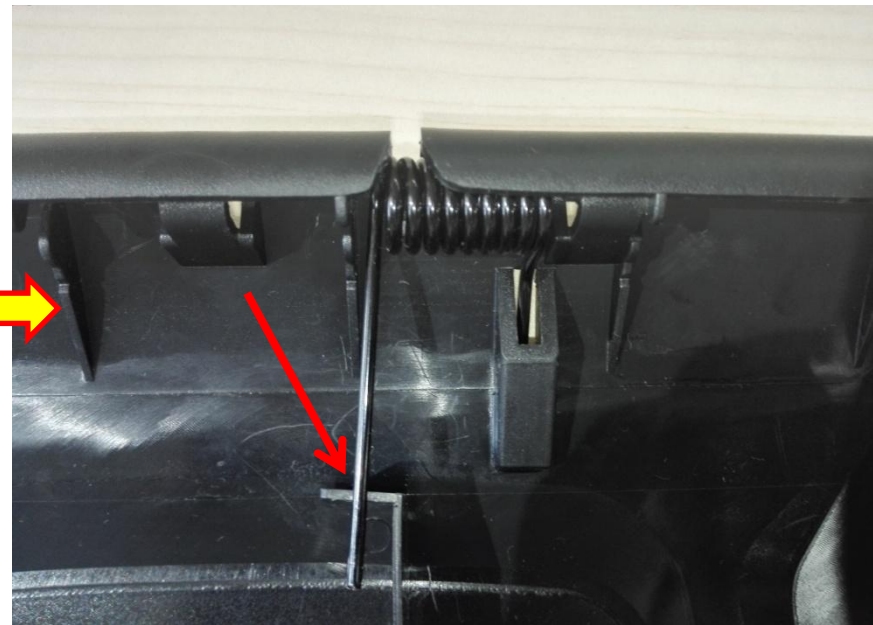

Rear Cover Replacement

LM2010E Lawn Mower

7. Position the rear cover and torsion spring assembly onto the deck. The foot of the spring should be in the deck groove.

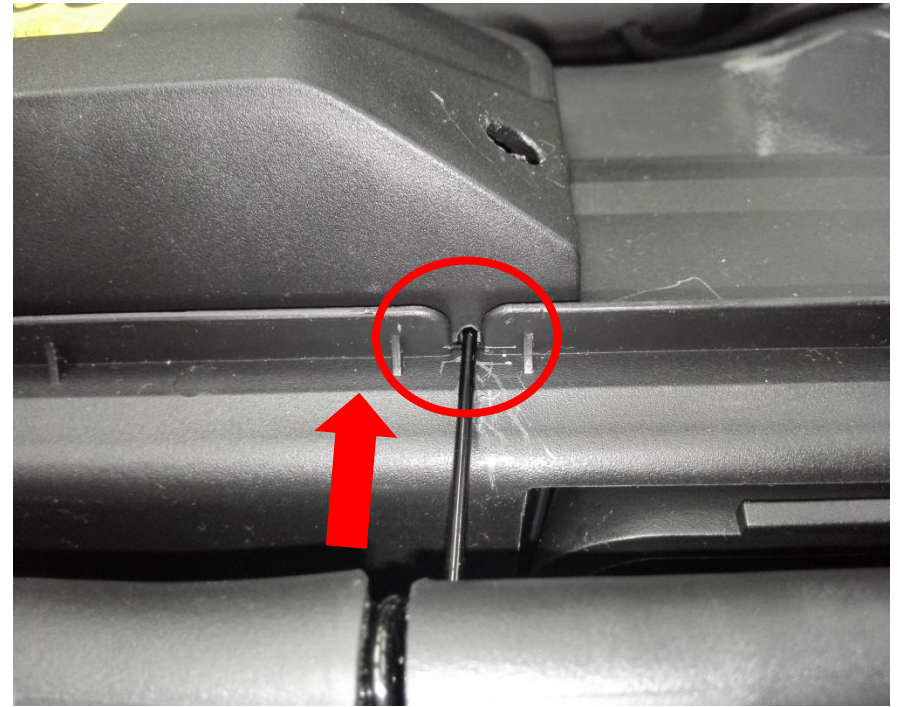

Rear Cover Replacement

LM2010E Lawn Mower

8. Insert the shaft both through the hole on the mower and the torsion spring, and push it into position.
9. Lift up the rear cover to check if it can rotate around the shaft smoothly. If it works well, mount the E-clip onto the shaft.



THE END

REPAIR GUIDELINE

PART 5: Main Switch & Handle Replacement _LM2010E Lawn Mower



Table of Contents

LM2010E Lawn Mower

NO.	Contents	Page
1	Replacing the Main Switch Unit	3-17
2	Replacing the Handle	18-21

1. Replacing the Main Switch Unit

LM2010E Lawn Mower

1. With the handle locked in the operating position, pull out the black main switch lever and green self-propel lever from their aligning holes.



2. Remove the 2 tapping screws to take down the main switch box with main switch lever.

Description	Part Number	SPEC	Qty
Tapping Screw	5610047006	4.2x38	2



1. Replacing the Main Switch Unit

3. If any distortion or malfunction appears in main switch lever, replace it with a new one by loosening the screw.

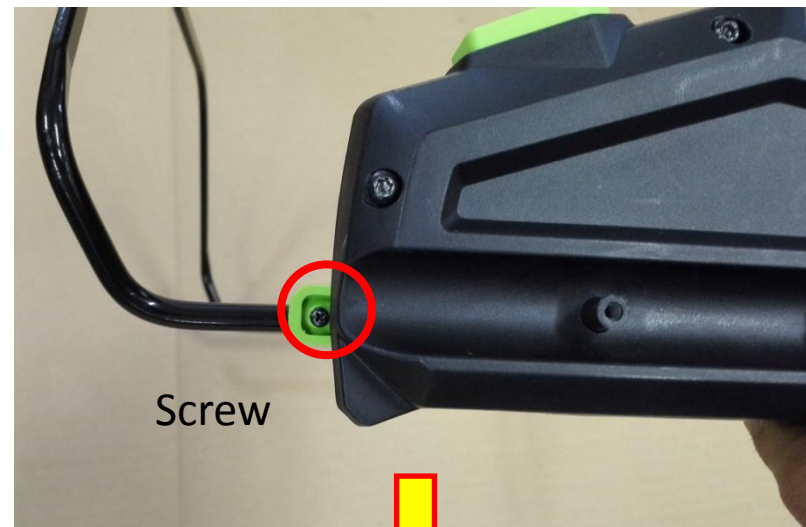
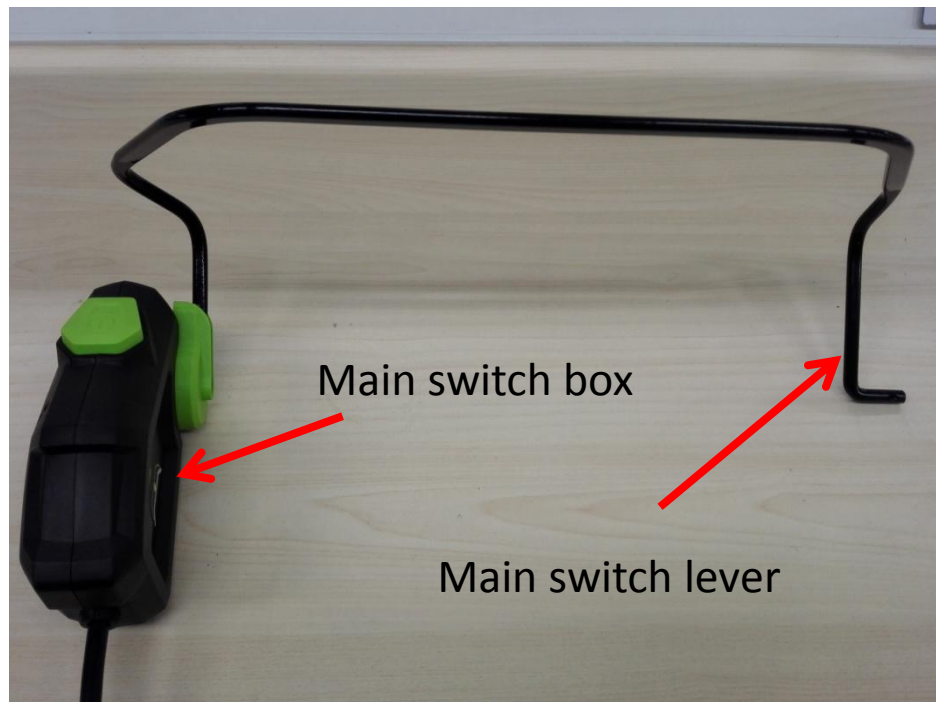

Description	Part Number	SPEC	Qty
Main Switch Lever	3650169001	-	1
Screw	5620033010	M3x10	1

1. Replacing the Main Switch Unit

4. Loosen the other 3 tapping screws and remove bottom switch box cover gently.

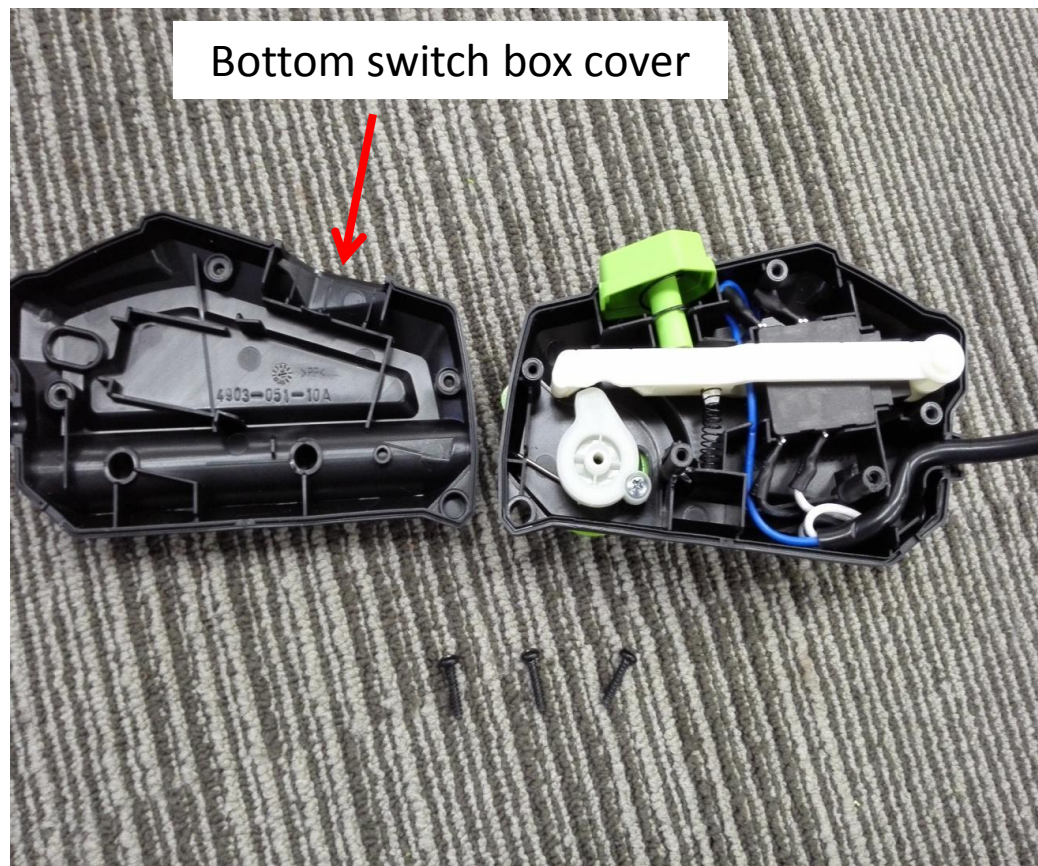

Description	Part Number	SPEC	Qty
Tapping Screw	5620157006	4.2x38	3

1. Replacing the Main Switch Unit

5. Replaced any damaged parts as shown in following figures below.

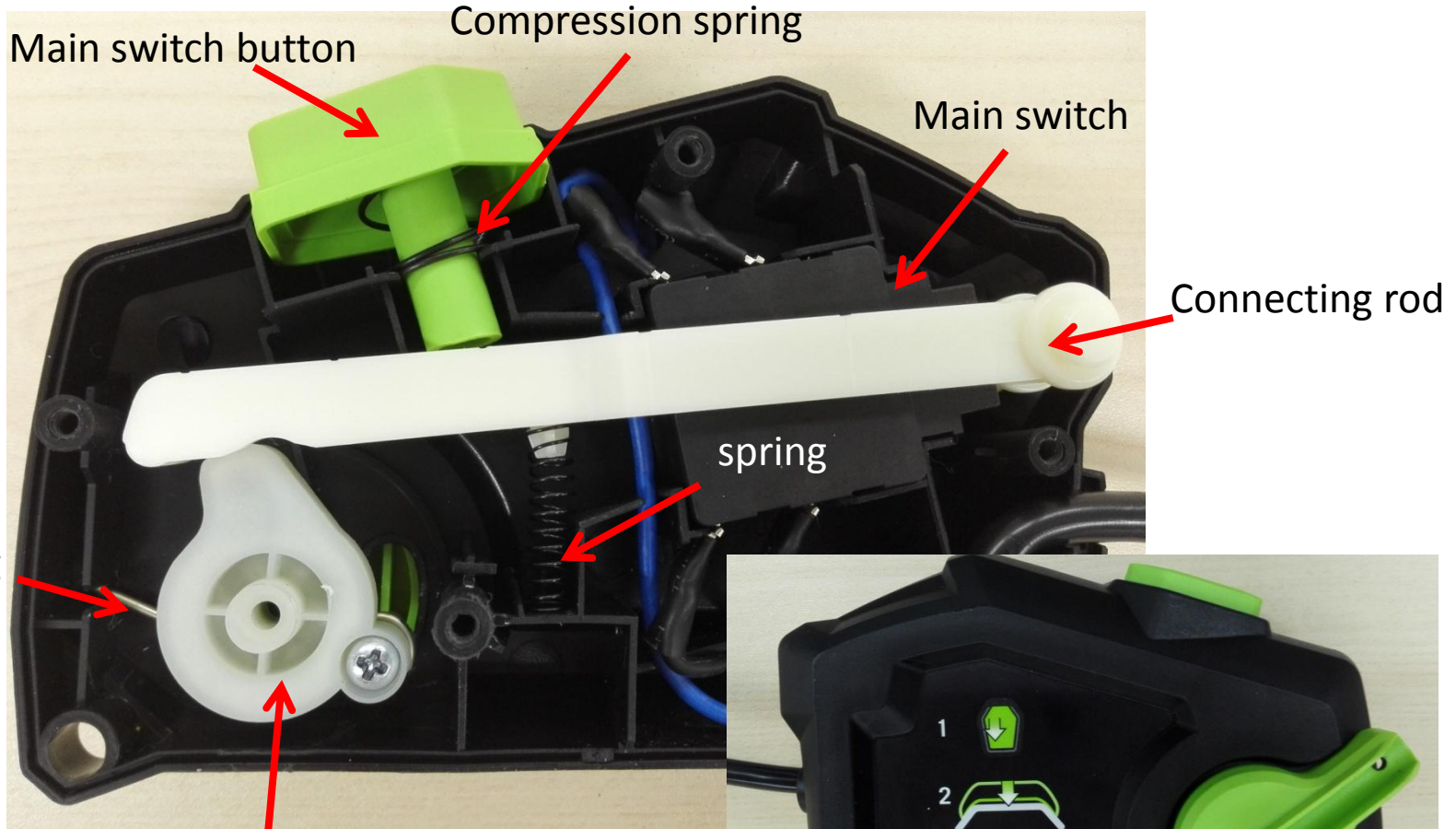

Switch lever

main switch trigger

1. Replacing the Main Switch Unit

The following parts can be replaced in this section.

Description	Part Number
Main Switch Button	3128062001
Compression spring	3660497001
Main Switch Trigger	3128061001
Torsion Spring	3660608001
Switch Lever	3128063001
Connecting Rod	3127948001
Main Switch	4870566001
Spring	3660399001

1. Replacing the Main Switch Unit

LM2010E Lawn Mower

6. Loosen the tapping screw to remove the switch lever, torsion spring and main switch trigger from the top main switch box. Then replaced any damaged parts.

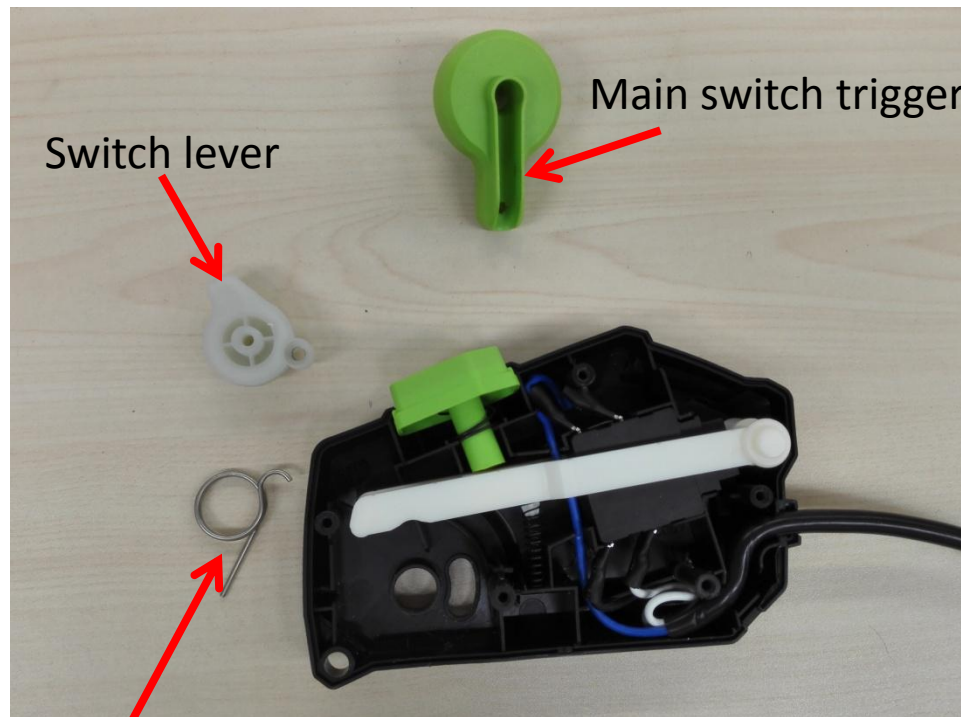
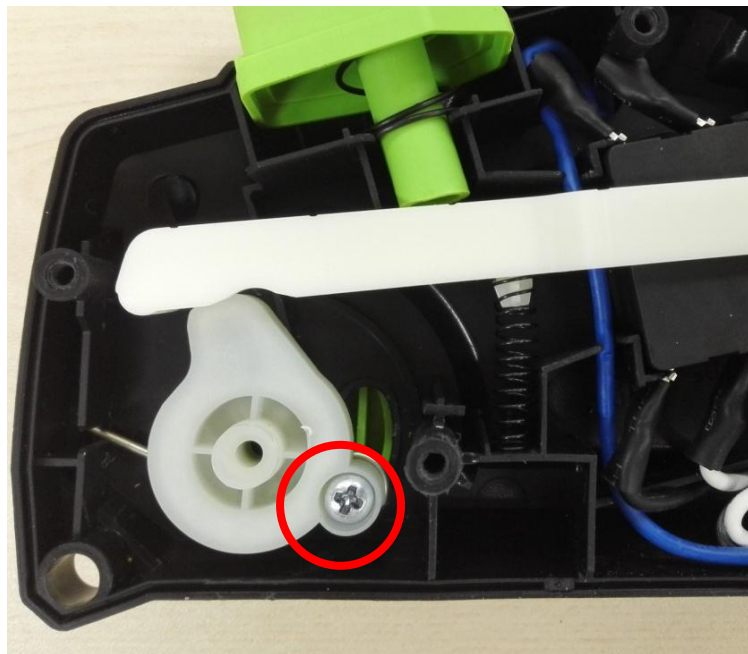

Switch lever

Main switch trigger

Torsion spring

Description	Part Number	Qty
Screw	5610044002	1

1. Replacing the Main Switch Unit

LM2010E Lawn Mower

7. Take down the main switch with connecting rod and spring. Then separate and replace them properly.

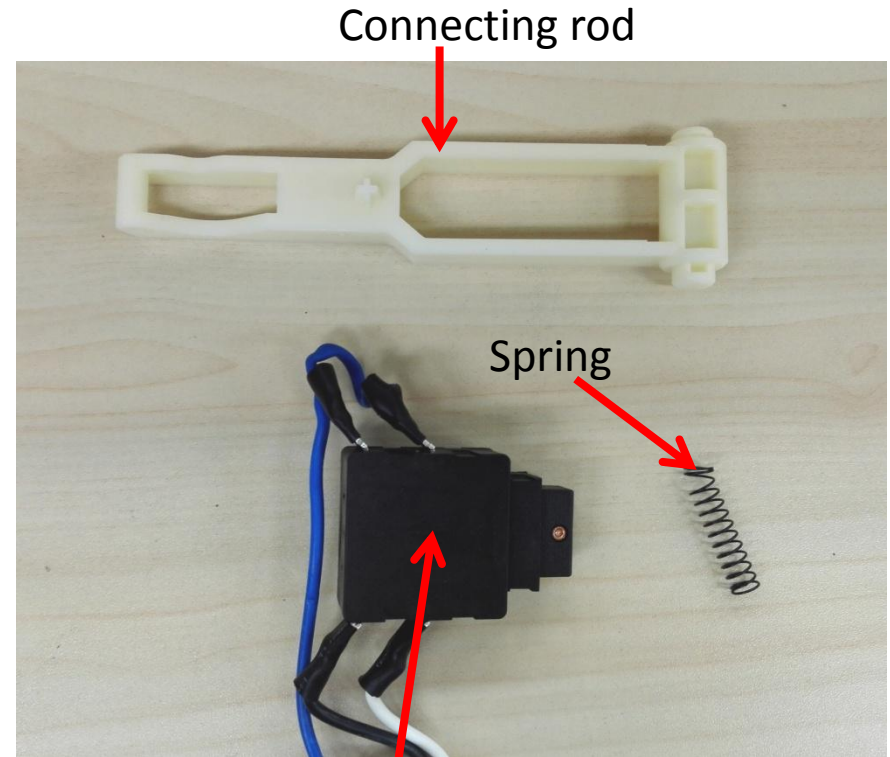
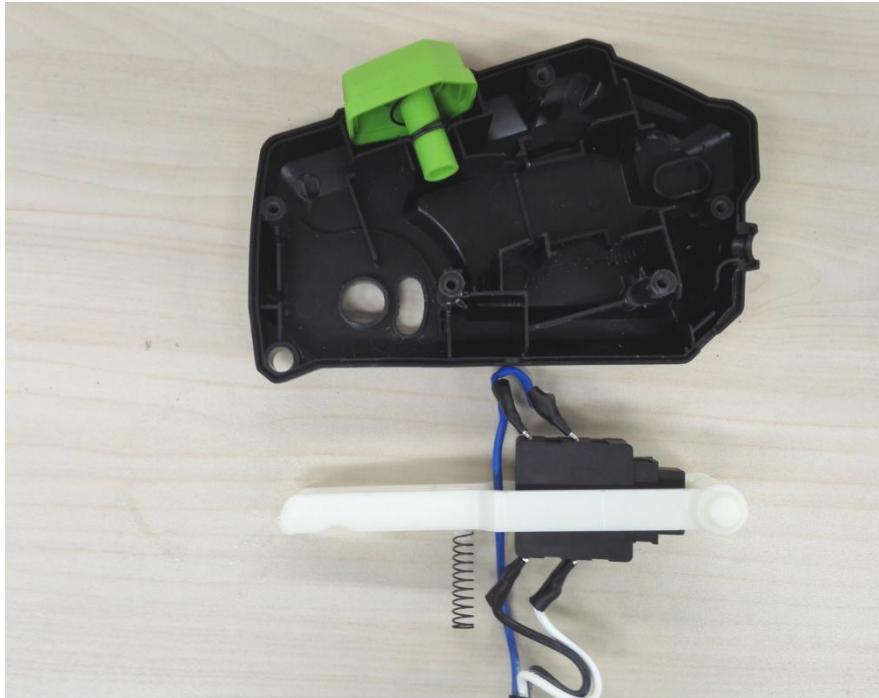

Connecting rod

Spring

Main switch

1. Replacing the Main Switch Unit

LM2010E Lawn Mower

8. If the main switch button and compression spring are damaged, replace them with a new one as an independent part from other parts in the main switch box.

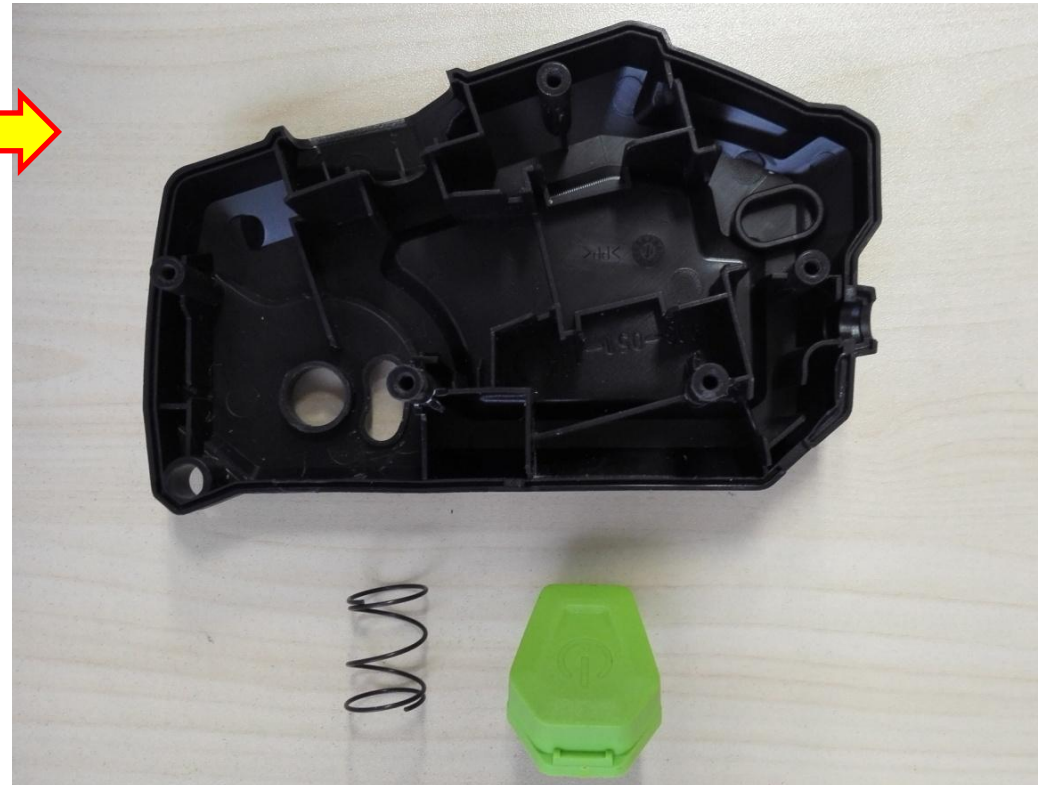

1. Replacing the Main Switch Unit

9. IF the main switch is broken, disconnect it from the wires and replace with a new one by re-soldering.

NOTICE: Soldering connection is as following picture show.

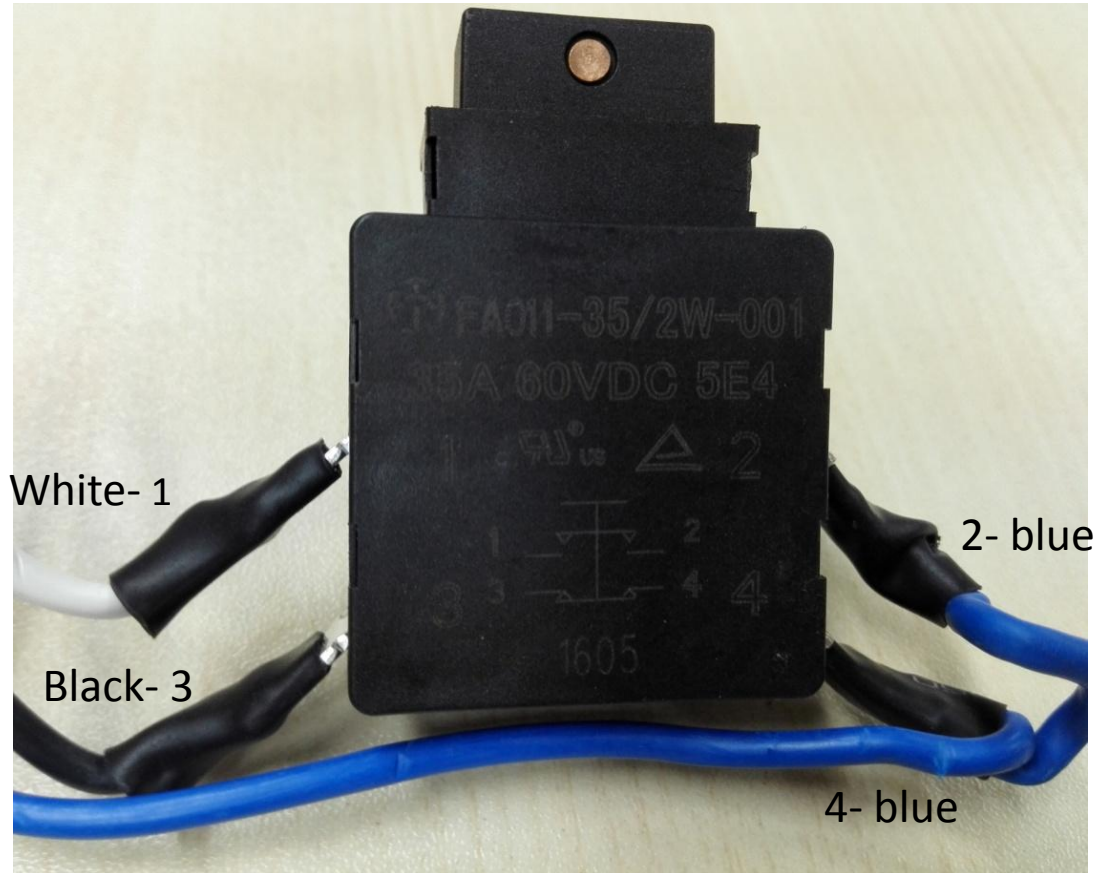

1. Replacing the Main Switch Unit

LM2010E Lawn Mower

10. Insert the new main switch into the full opening groove of connecting rod. Then mount the connecting rod with main switch into top switch box cover (see next slide).

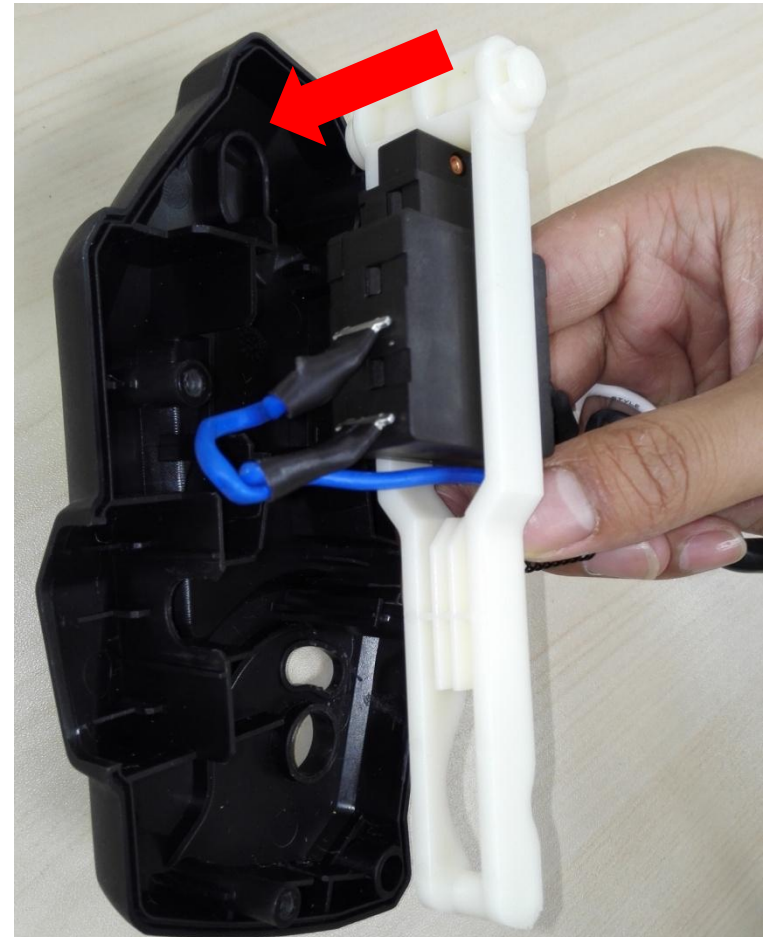
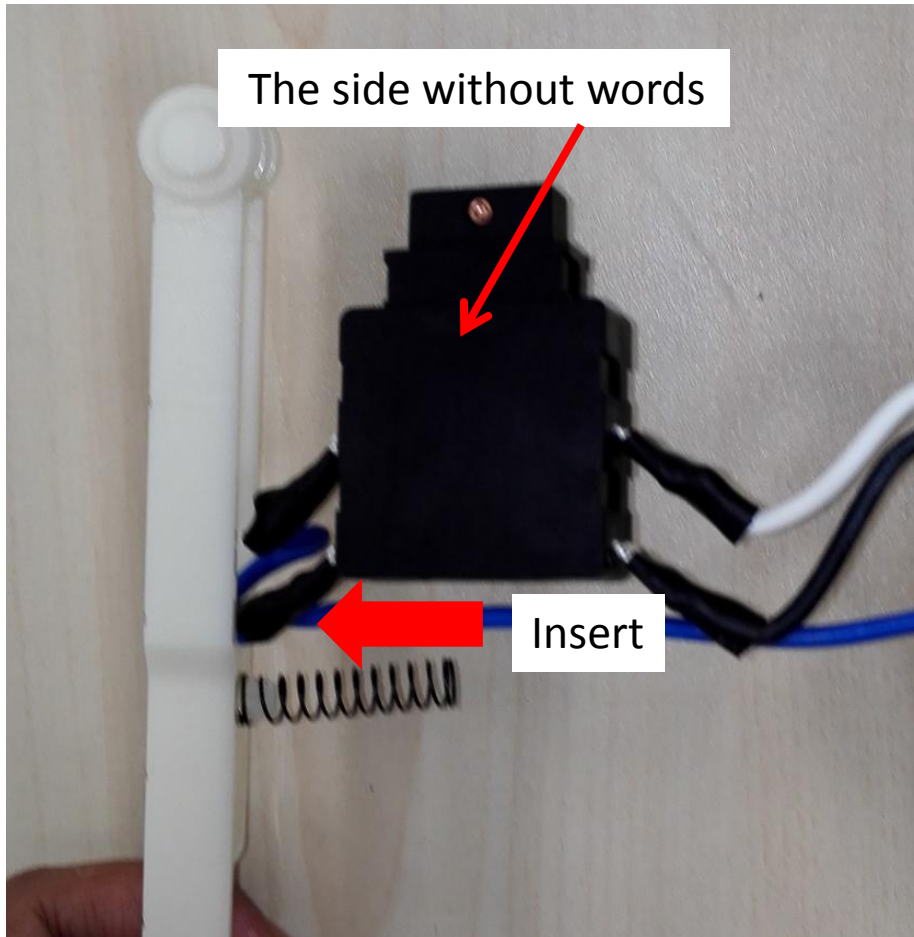

1. Replacing the Main Switch Unit

LM2010E Lawn Mower

11. Mount the main switch and connecting rod into place following the figures below.

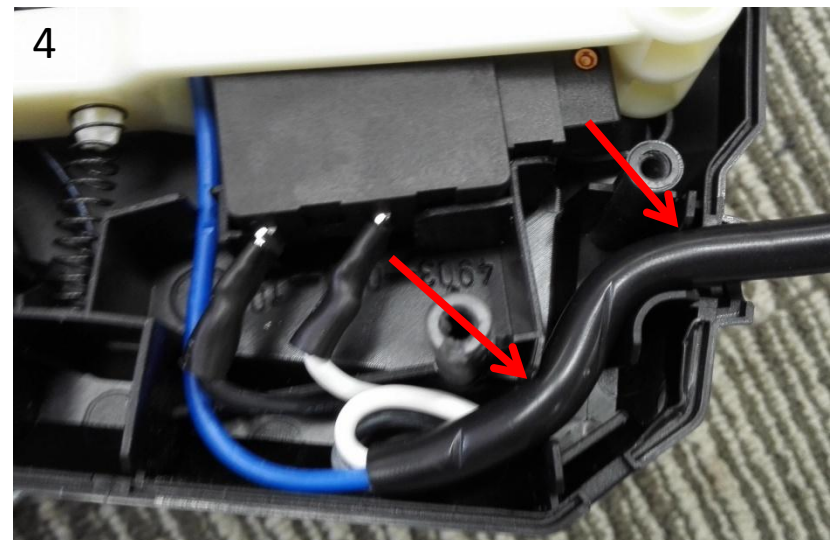
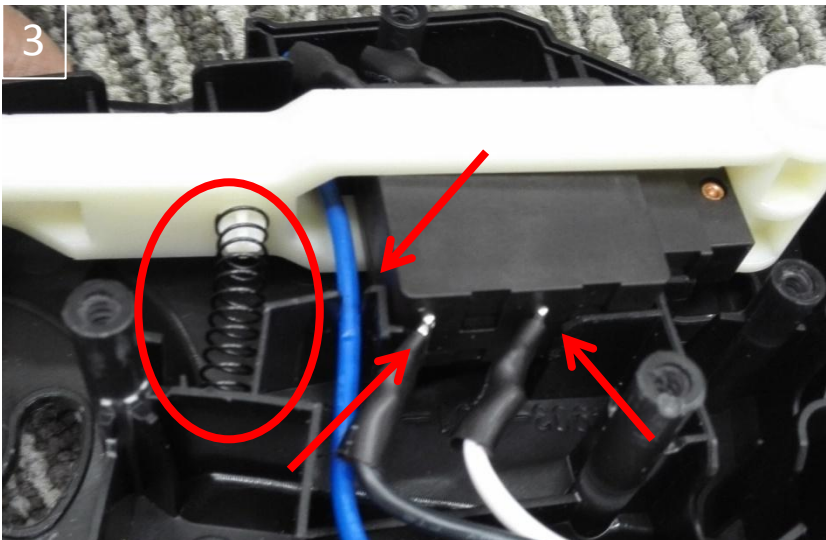
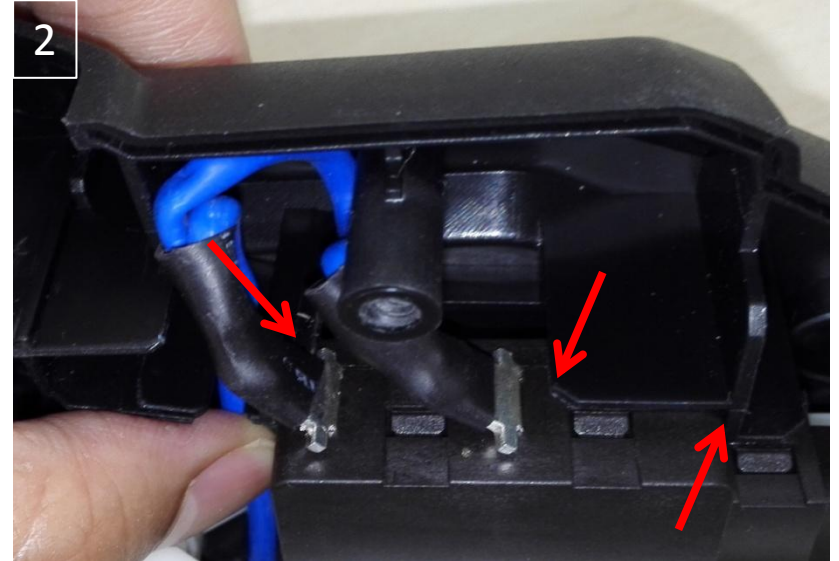
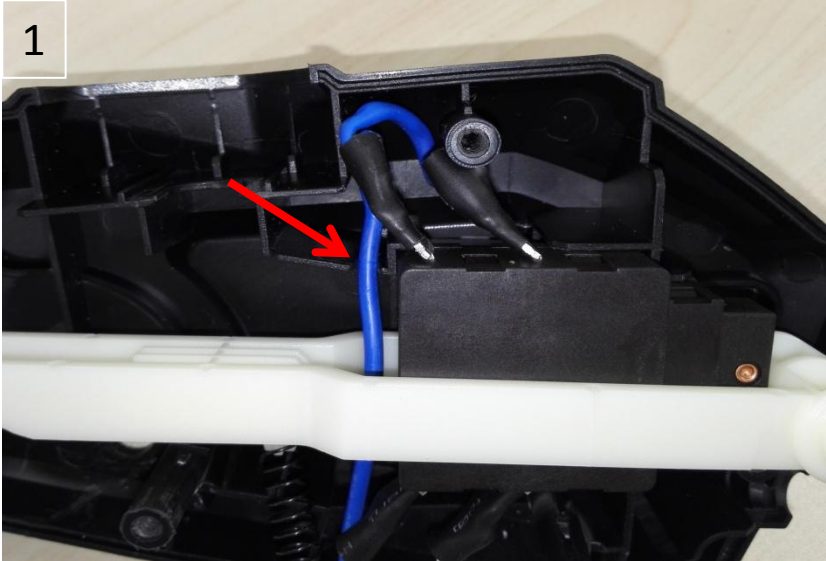

1. Replacing the Main Switch Unit

LM2010E Lawn Mower

12. Mount the main switch trigger into the mounting groove in top switch box cover.
13. Place the torsion spring into its place.

NOTIC: The torsion spring should hook the pole of button and get stuck in the housing groove.



Top switch box cover

Main switch trigger

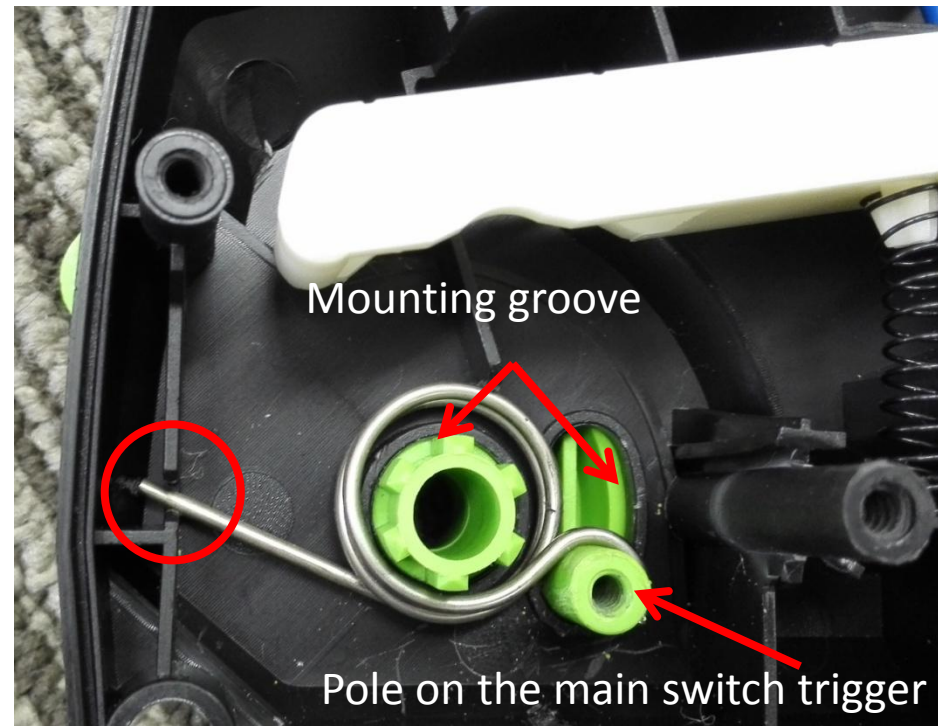

Mounting groove

Pole on the main switch trigger

1. Replacing the Main Switch Unit

LM2010E Lawn Mower

14. Lock the switch lever by tightening the screw.
Make sure the point of switch lever is inserted into the full opening of connecting rod.
15. Insert main switch button to the locating slot.

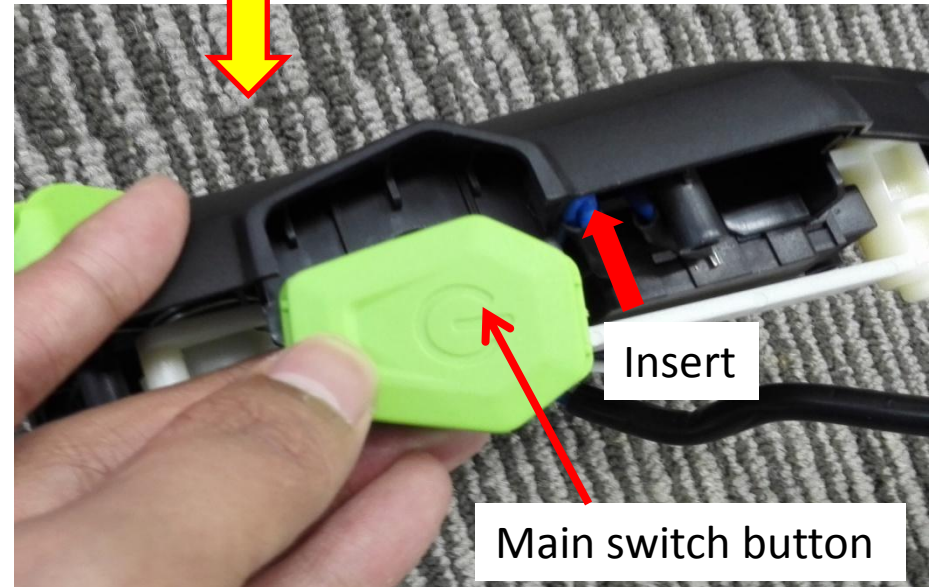
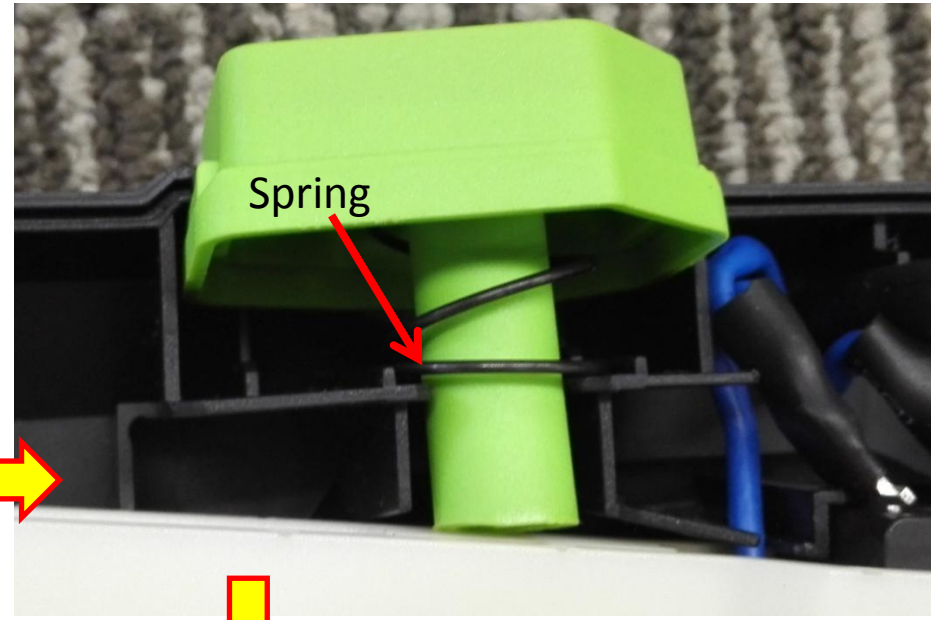
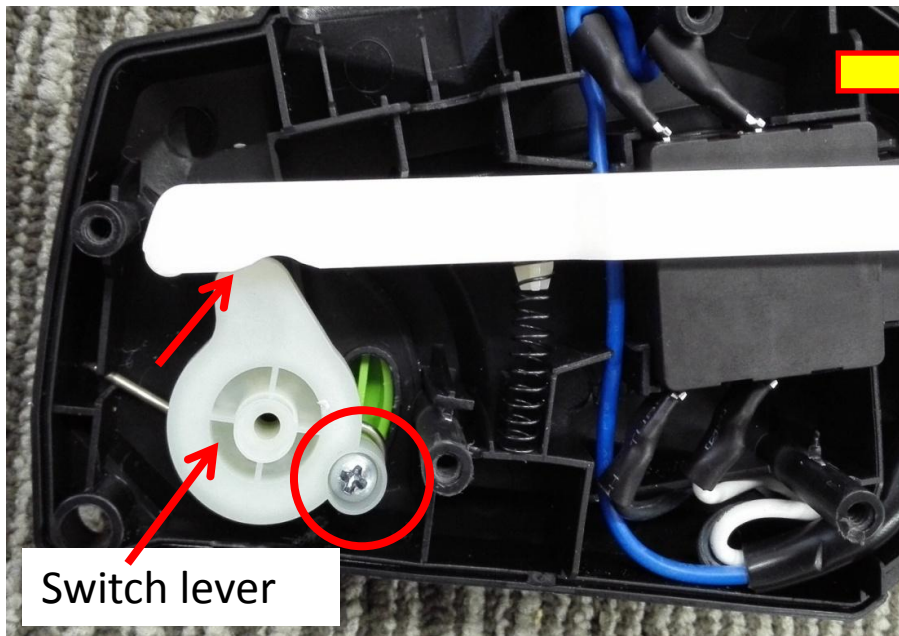

1. Replacing the Main Switch Unit

LM2010E Lawn Mower

16. Close the main switch box and fix them with the 3 screws on the bottom switch box cover.

17. Mount the main switch level into the main switch trigger and fix them with a screw.

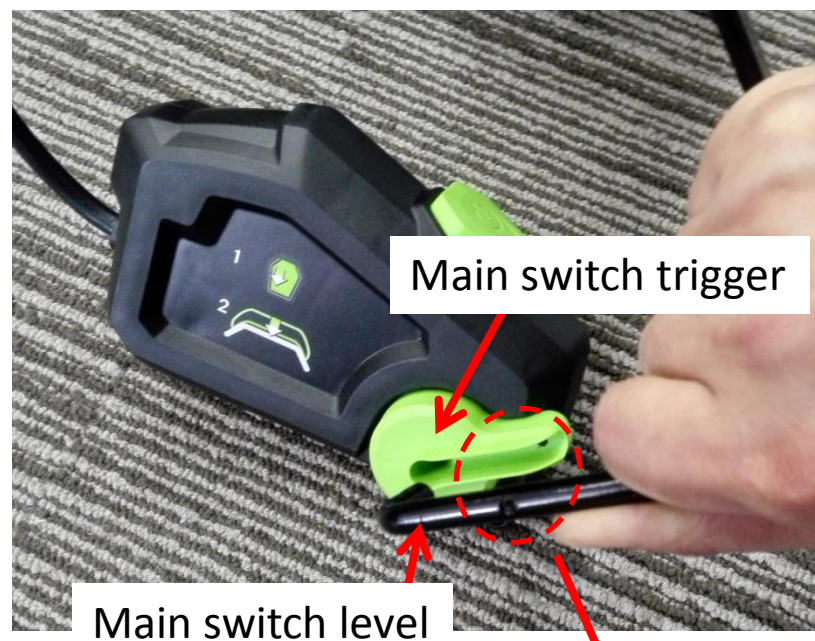

Test the push switch:

- Insert a fully charged battery pack into the mower.
- Adjust the handle to the operating position.
- Press the main switch button and rotate main switch trigger to check if the mower can be turned on properly.



1. Replacing the Main Switch Unit

LM2010E Lawn Mower

18. Fix main switch box on the handle following the steps as shown in figures below.



19. Mount the black main switch lever and green self-propelled lever into their aligning holes.



2. Replacing the Handle

LM2010E Lawn Mower

1. Take down the main switch box, main switch lever and bush referring to the section 1 in this guide.
2. Replace with a new bush if it is damaged.

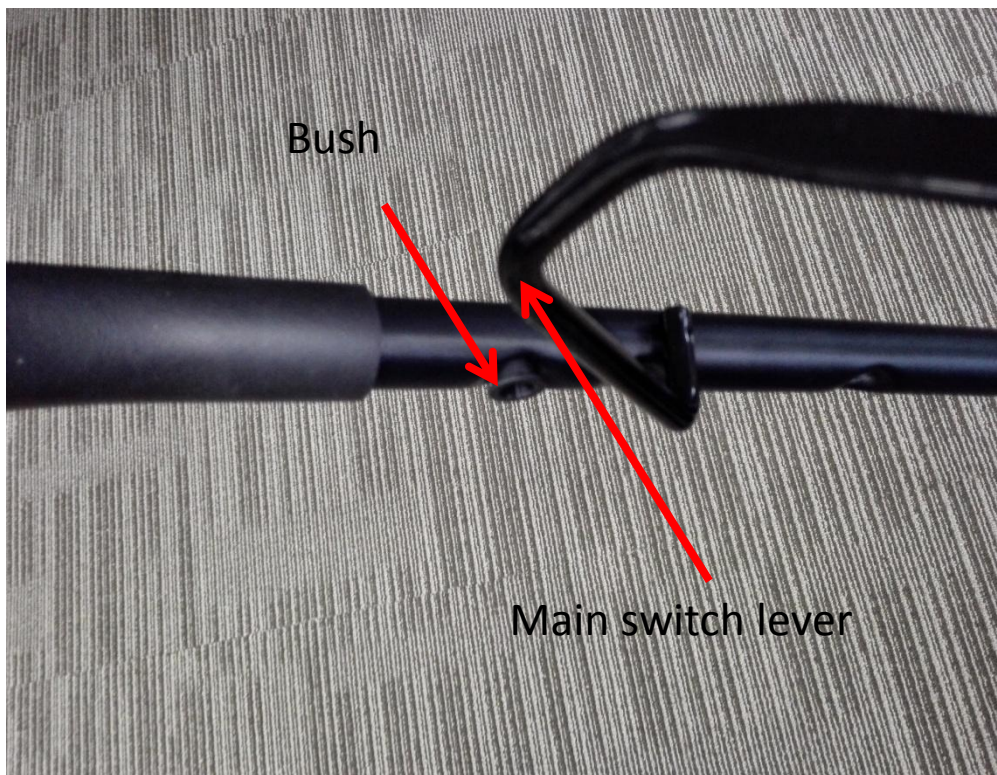

Description	Part Number
Bush	3128065001

2. Replacing the Handle

LM2010E Lawn Mower

3. Separate the quick adjust knob (see part 6) and wire holder from the handle.

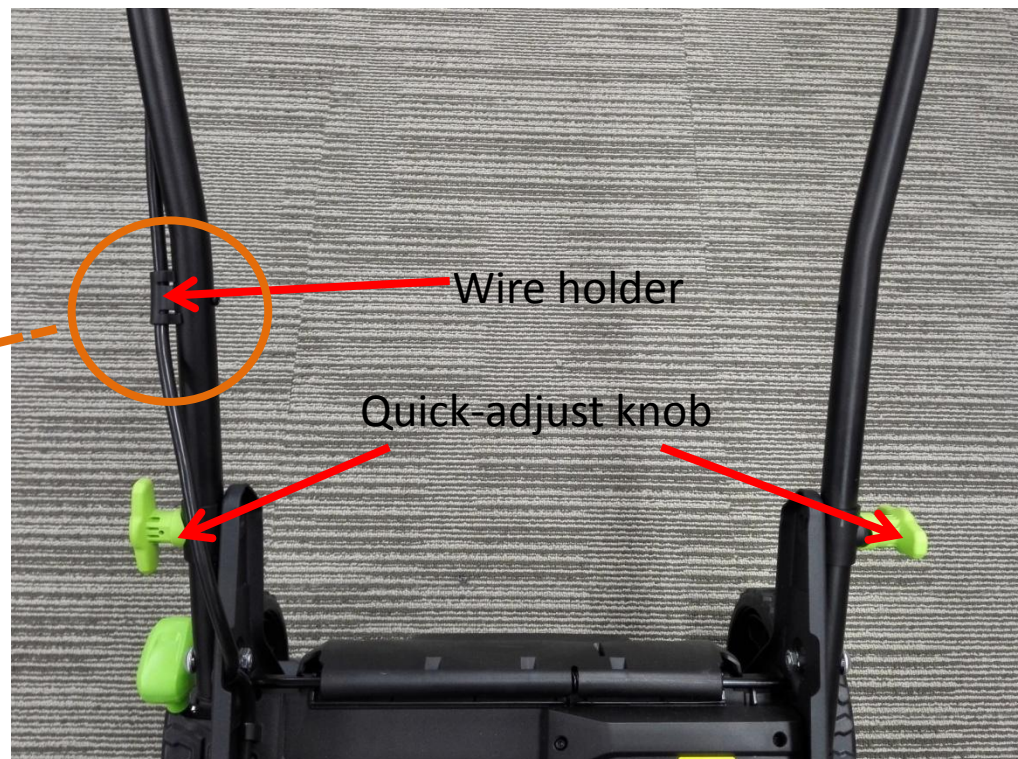

Description	Part Number	Qty
Tapping Screw	5620157006	1
Wire Holder	3126639001	1

2. Replacing the Handle

4. Remove the hexagon nut on the both sides (fig. 1).
5. Remove the screws with washer from the handle (fig. 2) and take down the handle with handle position switch trigger (fig. 3).

NOTIC: During this process, keep holding the handle to prevent dropping.



Description	Part Number	Qty
Screw	5640228001	Qty
Hexagon Nut	5630060004	2
Washer	3700095002	2
Top Handle	2824206001	1
Handle position switch trigger	3126580001	1

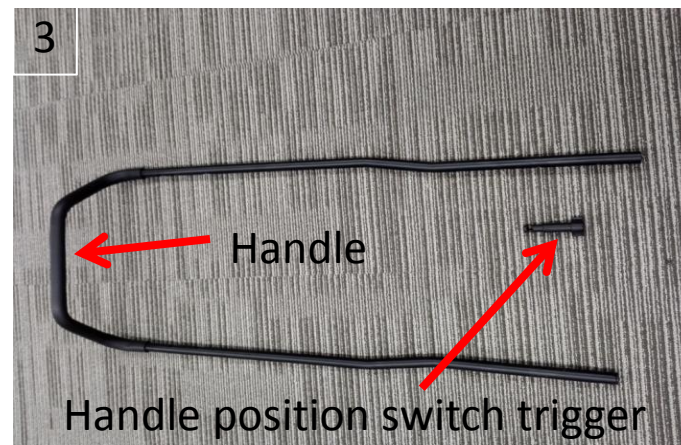

2. Replacing the Handle

6. Replace with a new handle or handle position switch trigger if any damage appears. Then assemble it in reverse order.

NOTIC: Should mount the handle position switch trigger in correct position.

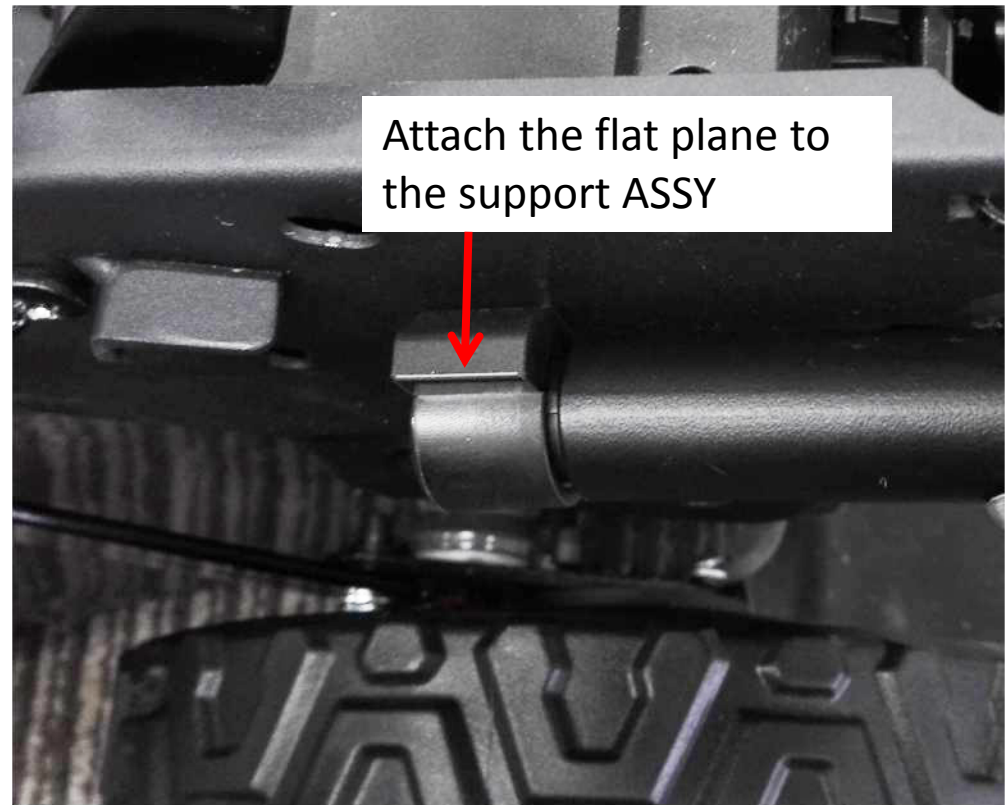

THE END

REPAIR GUIDELINE

PART 6: Wheels Replacement_LM2010E Lawn Mower



Table of Contents

LM2010E Lawn Mower

NO.	Contents	Page
1	Rear Wheels Replacement	3-5
2	Front Wheels Replacement	6-7

1. Rear Wheels Replacement

If the rear wheel is damaged, replace it.

1. Turn the mower on its back or side and separate the hubcap with a screwdriver.



Description	Part Number	SPEC
Hubcap	3126765001	-
Hex bolt	5640010003	M8×12

1. Rear Wheels Replacement

LM2010E Lawn Mower

- Remove the hex bolt using a socket wrench (S=13mm) to separate the wheel assembly from rear axle. If the wheel assembly is broken, replace it with a new one.

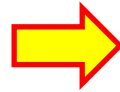

Socket wrench (S=13mm)

Description	Part Number
Wheel assembly	2824430001
Wave washer	5650453001

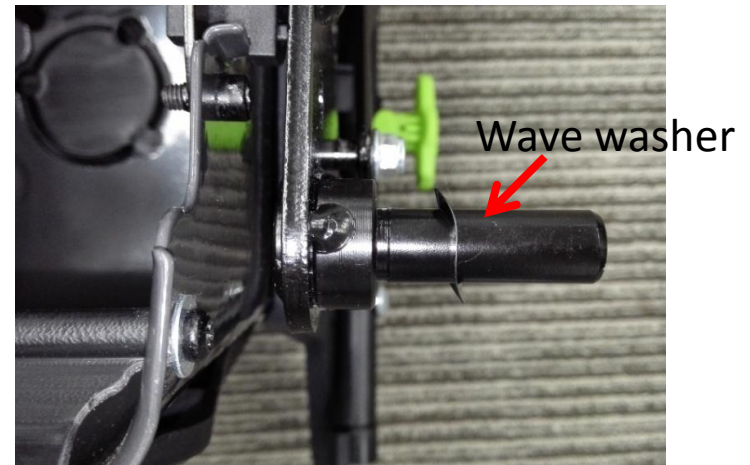

1. Rear Wheels Replacement

LM2010E Lawn Mower

3. Mount the wheel assembly onto the shaft of rear axle and fix it with the hex bolt. The recommended torque is 3.5-5Nm.
4. Insert the hubcap into the wheel.

2. Front Wheels Replacement

If the front wheel is damaged, replace it.

1. Separate the hubcap from the wheel and remove the hex bolt in the same way as rear wheels.



Description	Part Number
Hubcap	3126769001
Hex bolt	5640010003
Wheel assembly	2824429001
Wave washer	5650453001
Plain washer	5650032003

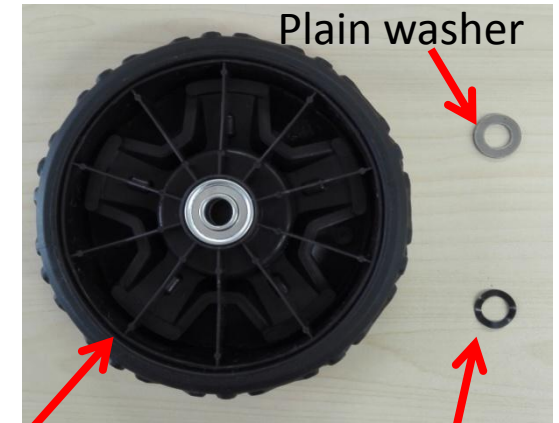

2. Front Wheels Replacement

LM2010E Lawn Mower

2. Replace with a new front wheel.
3. Mount it onto the shaft with the plain washer and wave washer beneath it.

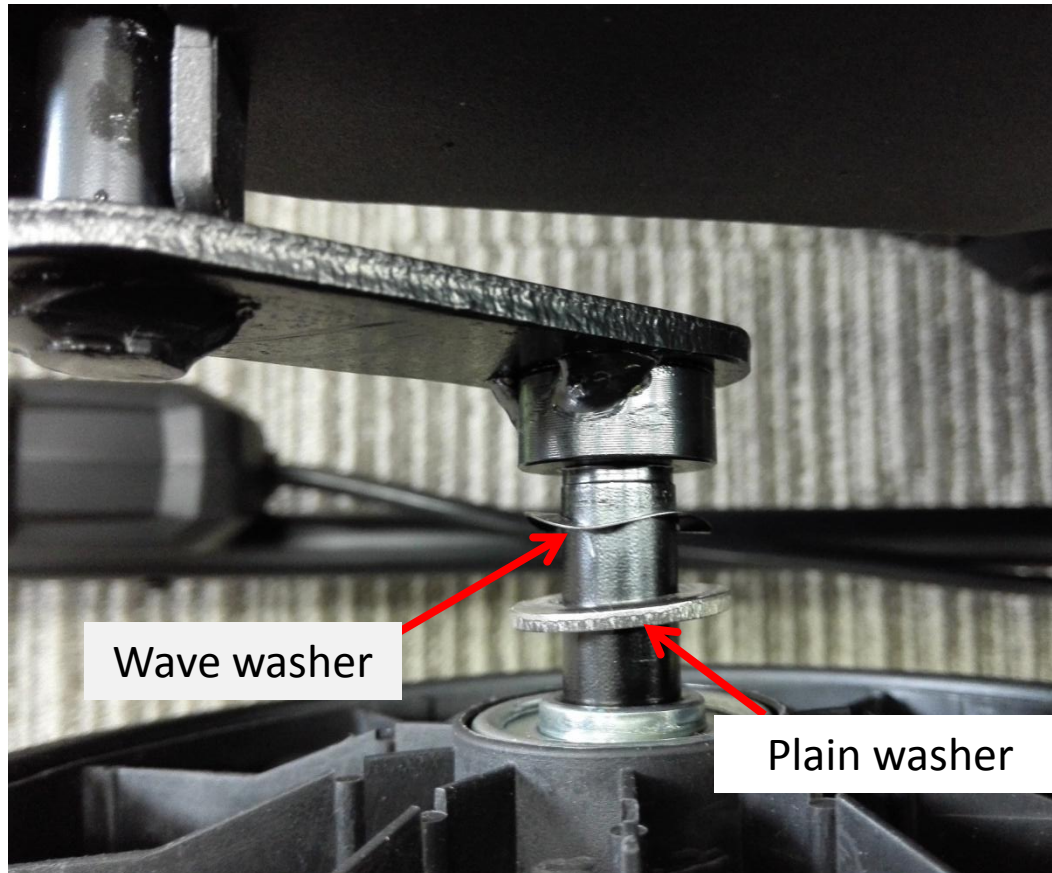

THE END

REPAIR GUIDELINE

PART 7: Adjusting Set & Rear Axle Set Replacement_LM2010E Lawn Mower



Table of Contents

LM2010E Lawn Mower

NO.	Contents	Page
1	Quick-adjust Knob Replacement	3
2	Rear Axle and cutting-height adjustment set Replacement	4-15

1. Quick-adjust Knob Replacement

LM2010E Lawn Mower

1. If quick-adjust knob is damaged, rotate the quick-adjust knob 90 degree and pull it out directly. Then replaced with a new one.



Description	Part Number
Quick-adjust Knob	2824261001

2. Rear Axle and Cutting-height Adjustment Set Replacement

LM2010E Lawn Mower

1. Turn the mower on its back to remove the rear wheel assembly and hubcap (see part 6).

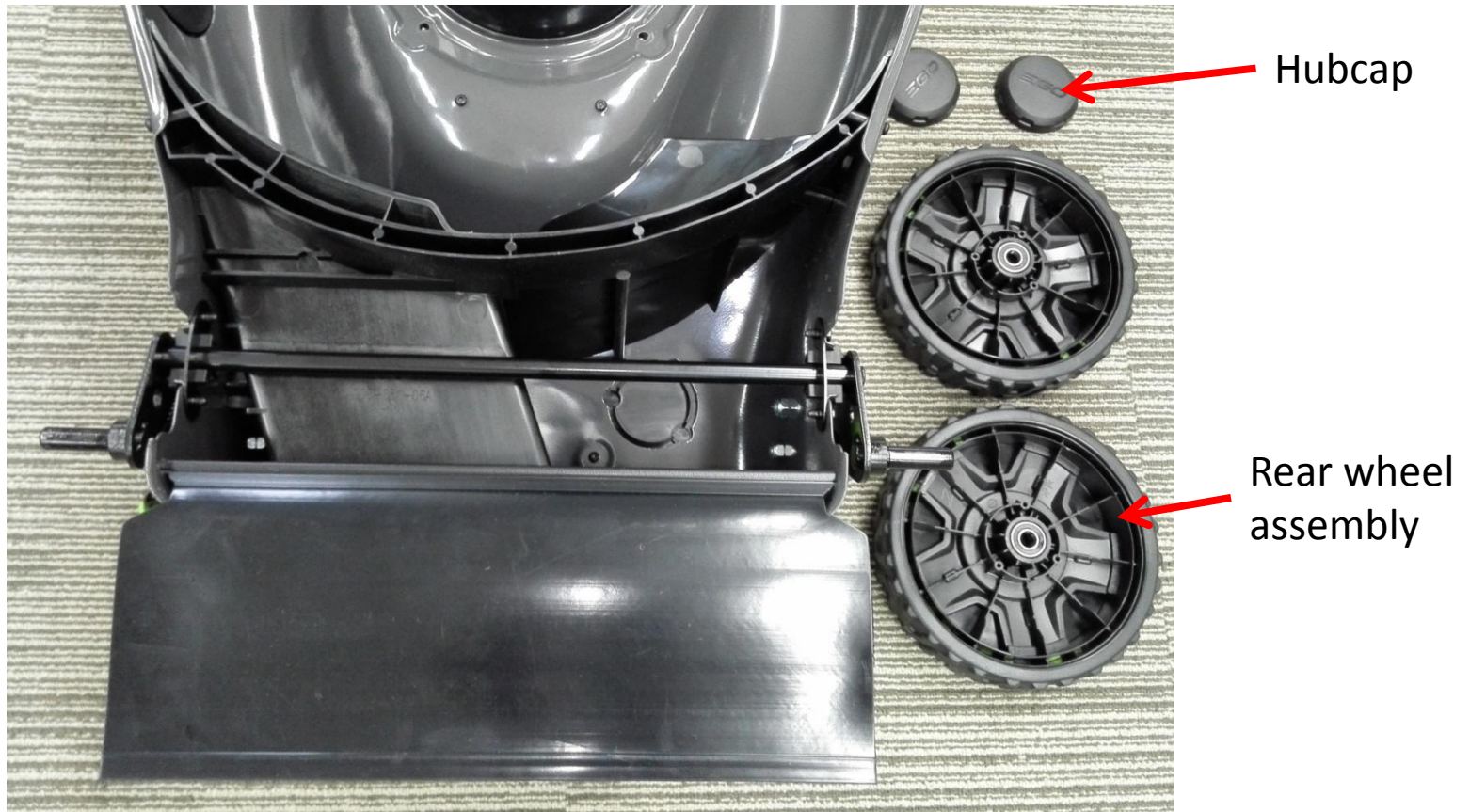

2. Rear Axle and Cutting-height Adjustment Set Replacement

2. Adjust the cutting height to [the position of 5](#) to remove the 4 screws and 2 mounting plates.

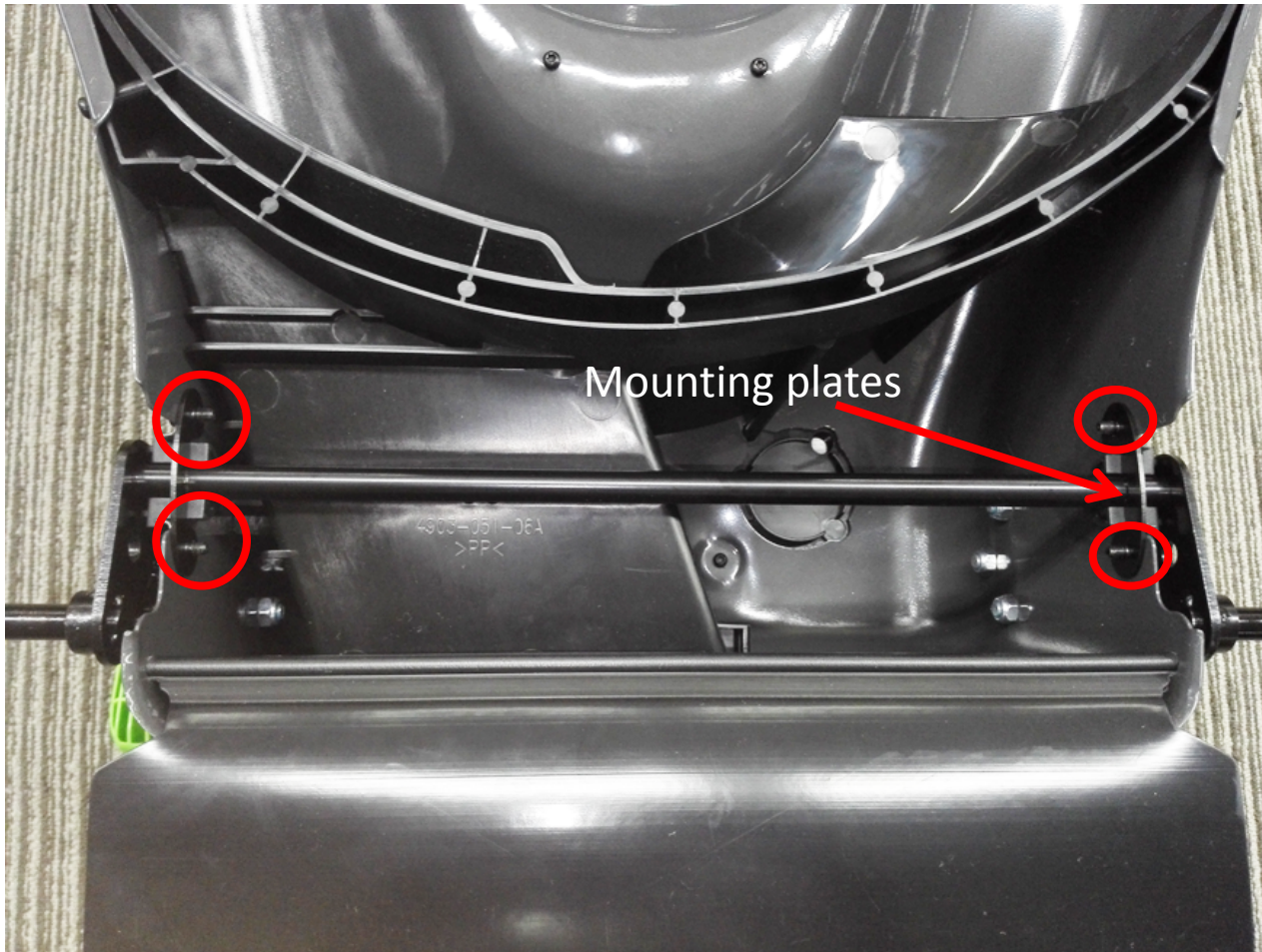

2. Rear Axle and Cutting-height Adjustment Set Replacement



The position of 5

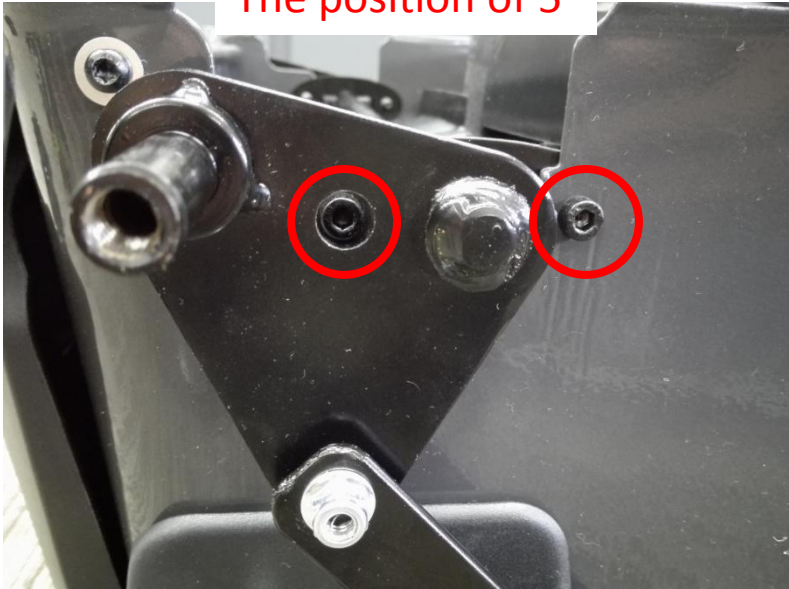

2. Rear Axle and Cutting-height Adjustment Set Replacement

3. Adjust the cutting height adjustment set to the position as fig. 1 show.



2. Rear Axle and Cutting-height Adjustment Set Replacement

4. Separate the connecting rod from rear axle by removing the prevailing torque hexagon nut 1 #.

NOTICE: If the connecting rod does not work normally, remove nut 2# to separate connecting rod from the mower.

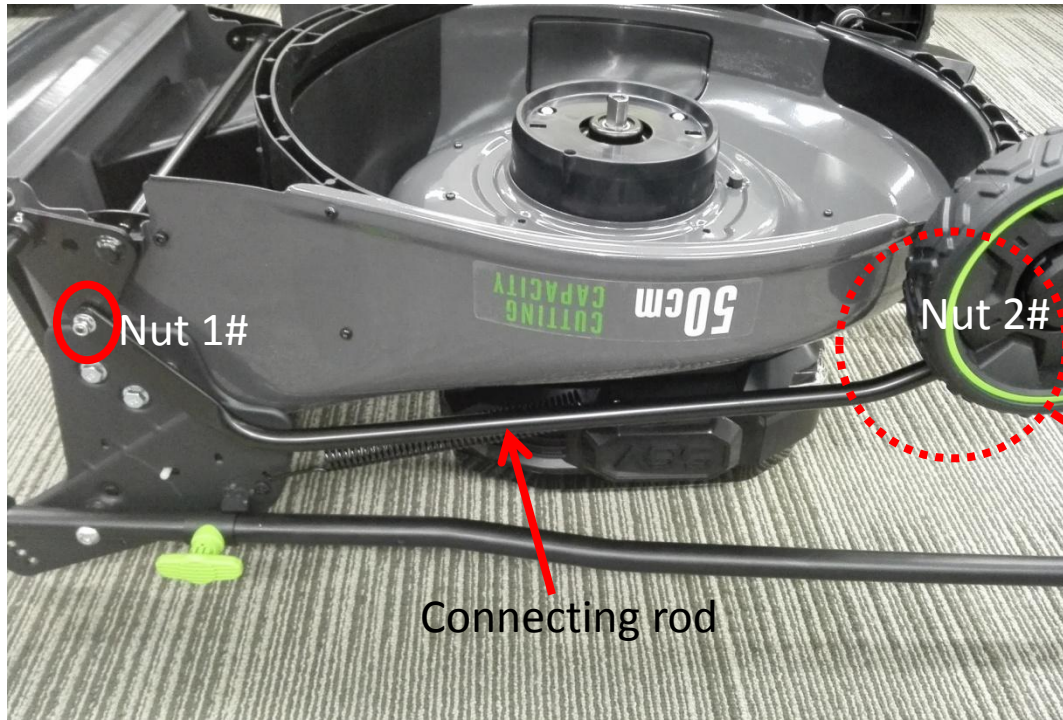

Prevailing torque hexagon nut

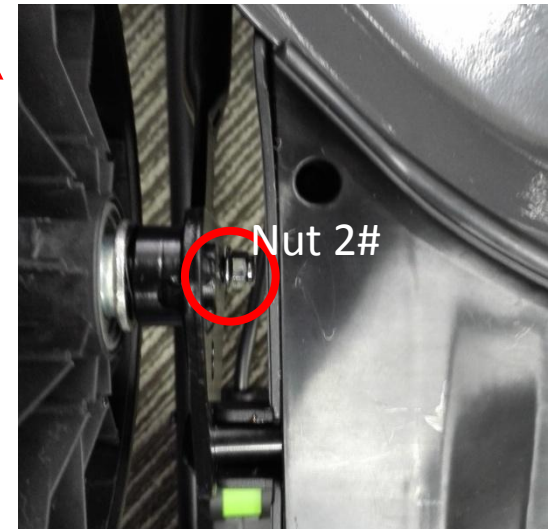

Description	Part Number	Qty
Prevailing Torque Hexagon Nut	5630013003	2

2. Rear Axle and Cutting-height Adjustment Set Replacement

5. Take down the rear axle set with cutting-height adjustment set from the mower.
6. Remove the pivot shoe from rear axle, replacing with a new one if it is damaged.

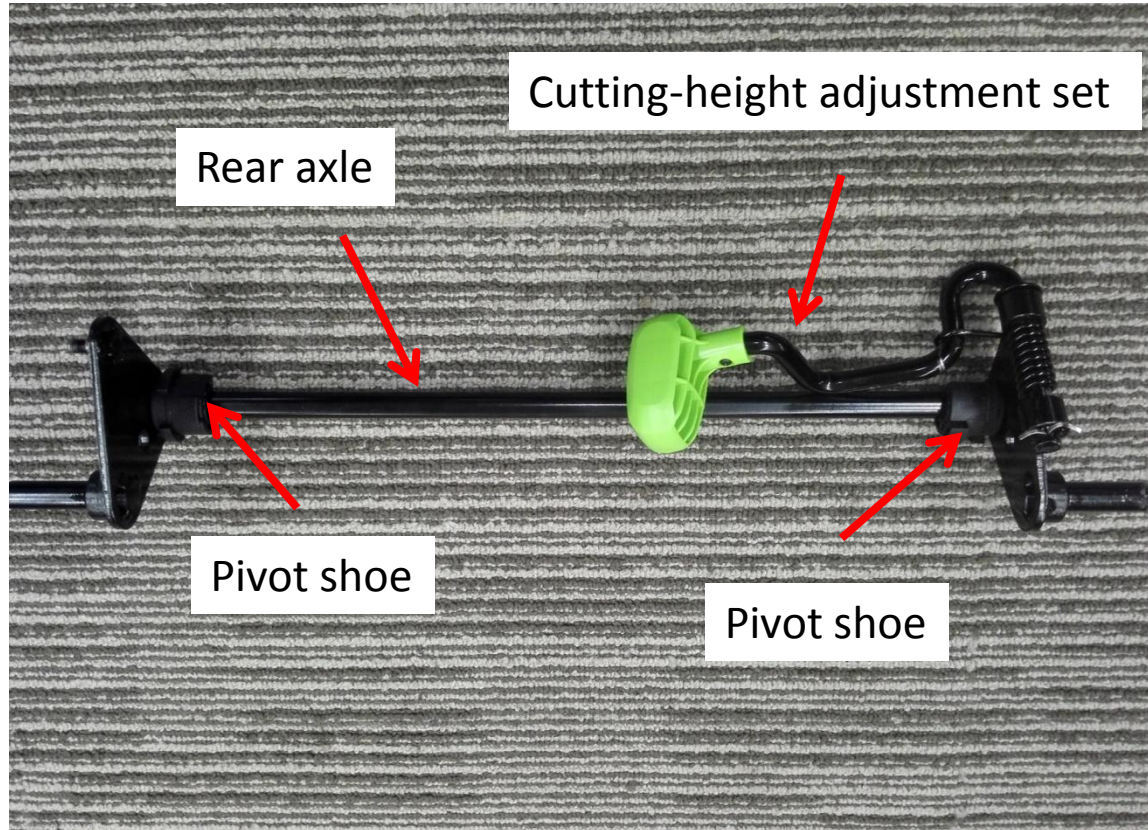

Description	Part Number	Qty
Pivot Shoe	3127964001	2

2. Rear Axle and Cutting-height Adjustment Set Replacement

7. Take cutting-height adjustment set out from the foot of the tension.



Description	Part Number
Tension spring	3660609001

2. Rear Axle and Cutting-height Adjustment Set Replacement

8. Bent the locking pin straight and draw the pin out by a pincher or other tools.

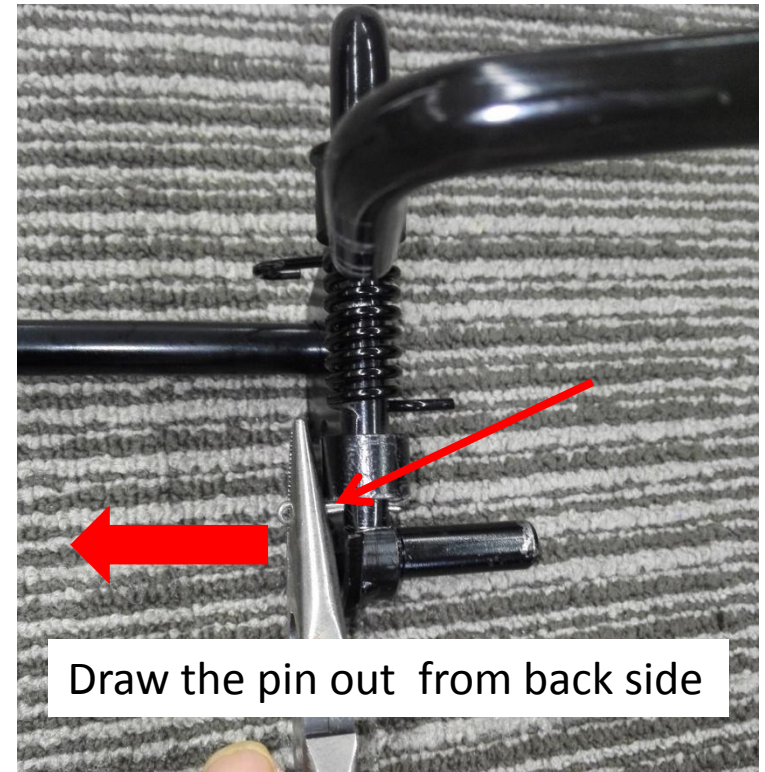
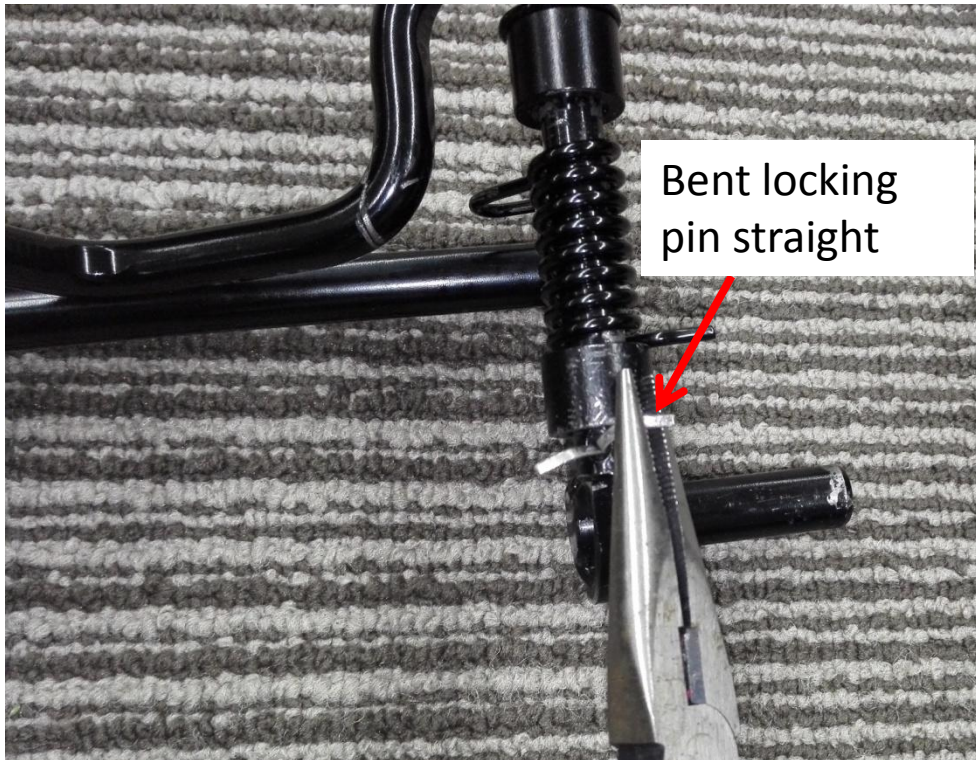

Description	Part Number
Locking Pin	5670184002

2. Rear Axle and Cutting-height Adjustment Set Replacement

9. Swing the cutting-height adjustment set out from rear axle set. If the cutting-height adjustment knob, lever or rear axle are damaged, replace them with a new part.

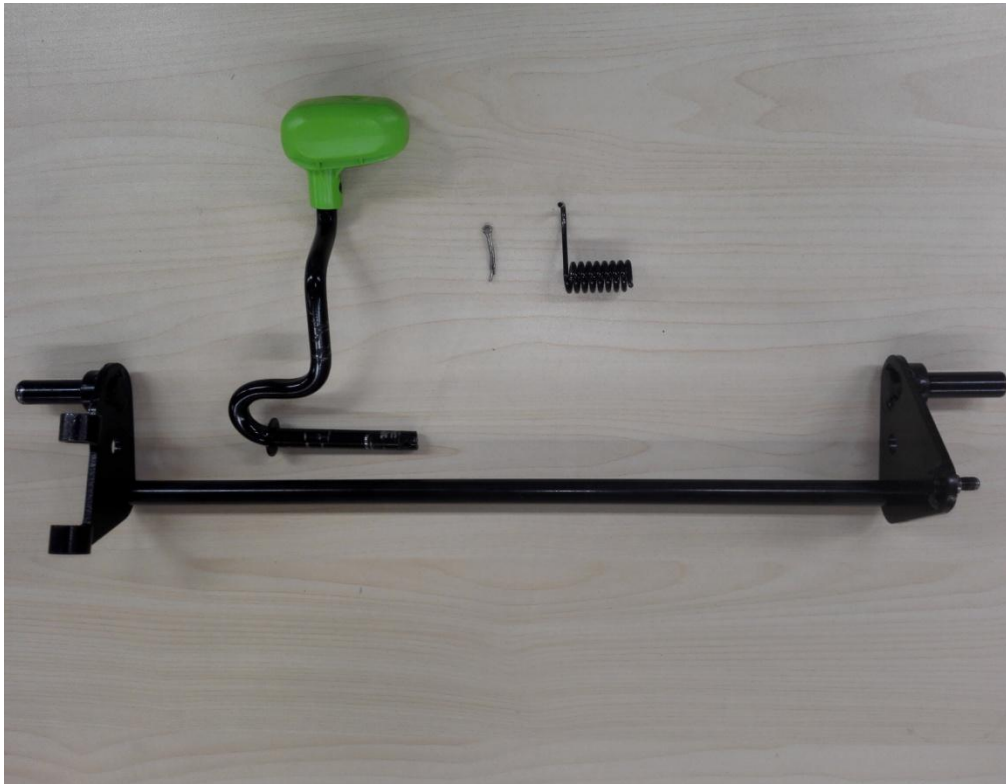

Description	Part Number
Cutting-height Adjustment knob	3126410001
Cutting-height Adjustment Lever	5620033005
Rear axle	2824346001

2. Rear Axle and Cutting-height Adjustment Set Replacement

10. Fix the cutting-height adjustment knob on the cutting-height adjustment lever with the screw.
11. Pass the cutting-height adjustment set through the two locating holes and tension spring.

NOTIC: The position of the tension spring should be mounted correctly.

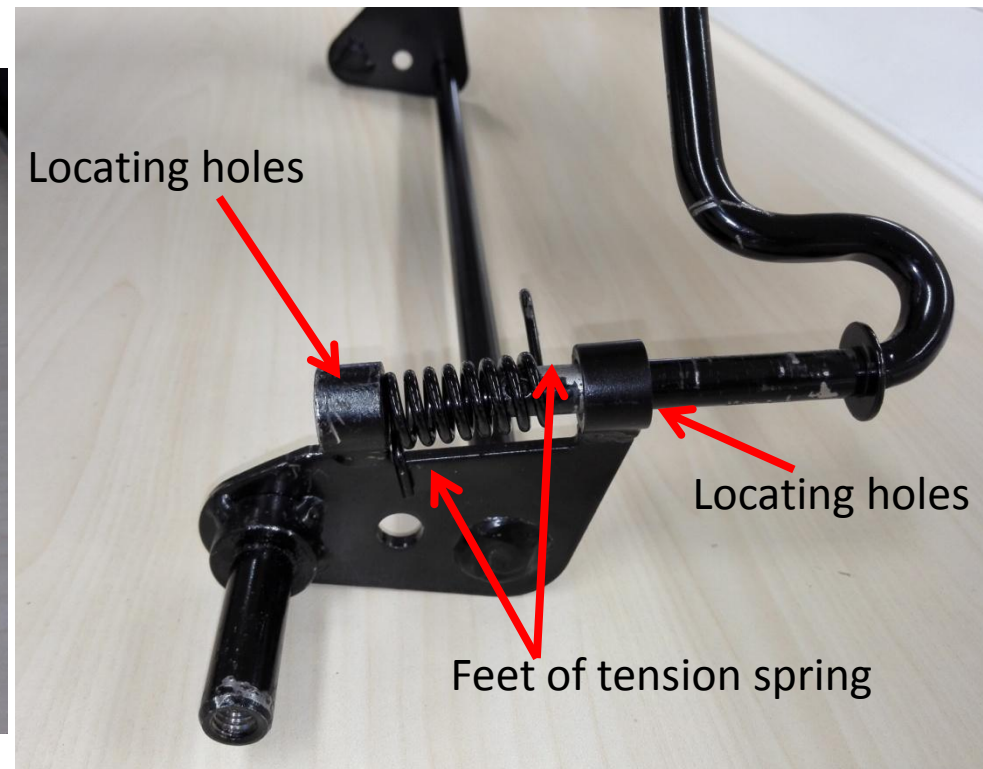

2. Rear Axle and Cutting-height Adjustment Set Replacement

12. Align the locking pin with the hole in cutting-height adjustment lever. Then bent the feet of the locking pin so that cutting-height adjustment set can be locked at the position.
10. Hook the tension spring on to the cutting-height adjustment lever.

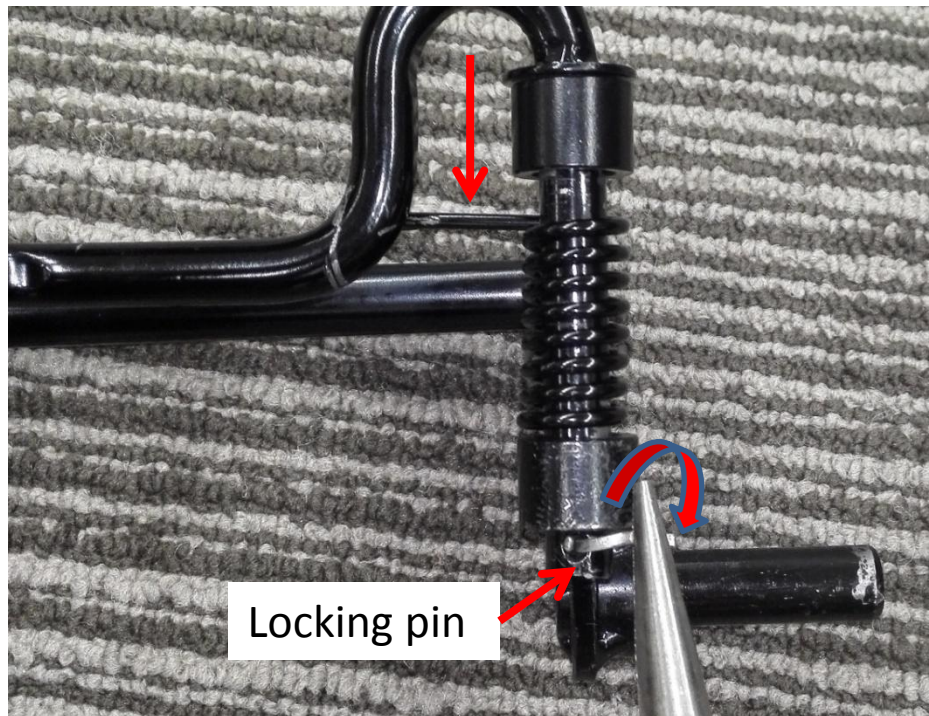

2. Rear Axle and Cutting-height Adjustment Set Replacement

14. Fix pivot shoes on the rear axle.
15. Mount the rear axle set with cutting-height adjustment set and rear wheel assembly onto the mower in reverse order.
16. Test the lever function to check if it can lock cutting –height adjustment set at different positions.

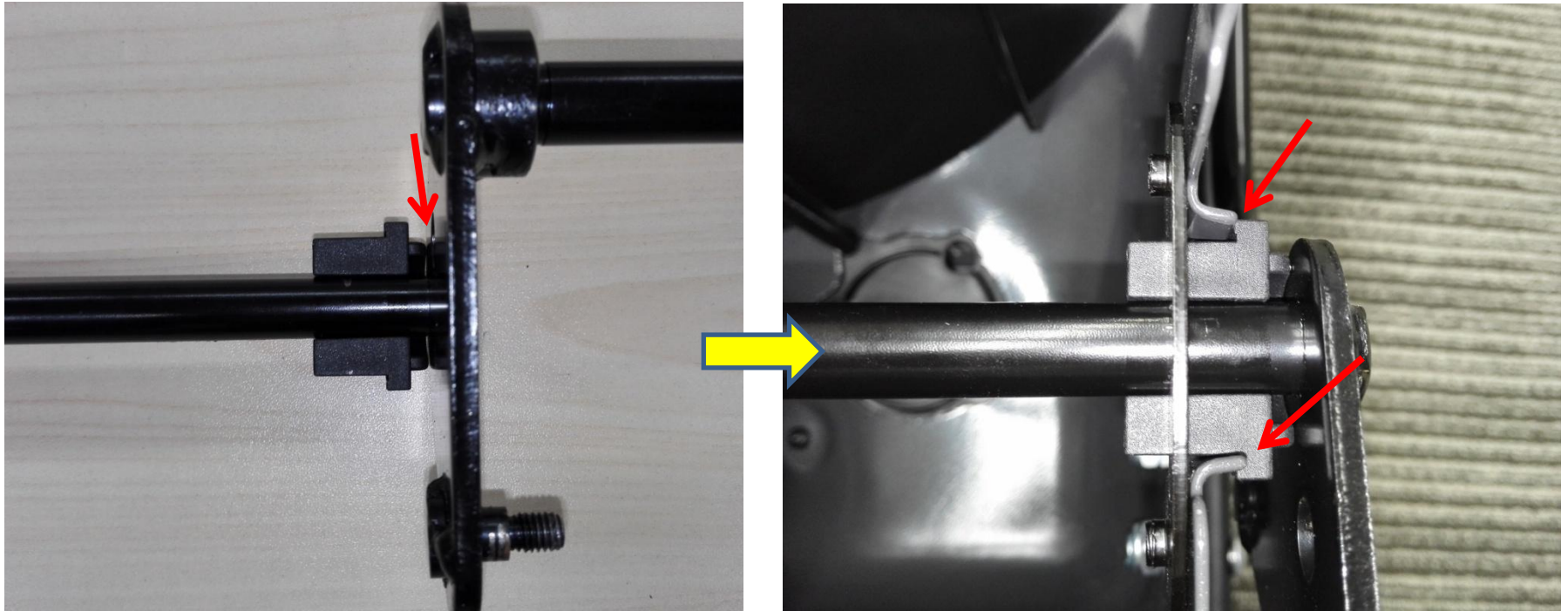

THE END

REPAIR GUIDELINE

PART 8: Handle Position Switch Replacement_LM2010E Lawn Mower



Handle position switch Replacement

LM2010E Lawn Mower

1. Before replacing the handle position switch, fold the handle to operating position to remove the rear handle and rear service cover from the mower.

NOTICE : Tilt the rear handle out of the mower properly.



Handle position switch Replacement

2. Replace with a new rear handle or rear service cover if any broken occurs.



Description	Part Number	SPEC
Screw 1	5620157006	ST4.2x19
Screw 2	5620369004	M6x12
Rear Handle	2824349001	-
Rear Service Cover	3126337001	-

Handle position switch Replacement

LM2010E Lawn Mower

3. Remove the cord anchorage by loosening two tapping screws.
4. Take out the handle position switch with cable from the bottom housing.
5. Separate the rotating block from the bottom housing. Replace with a new rotating block if it shows malfunction.

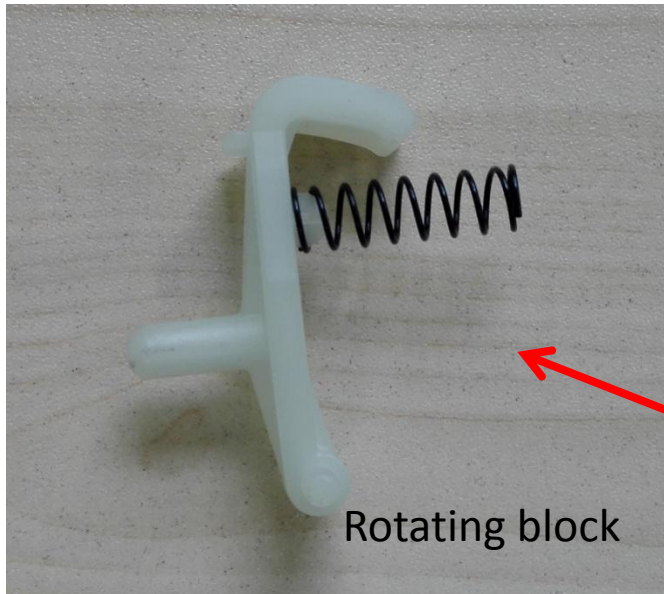

Rotating block

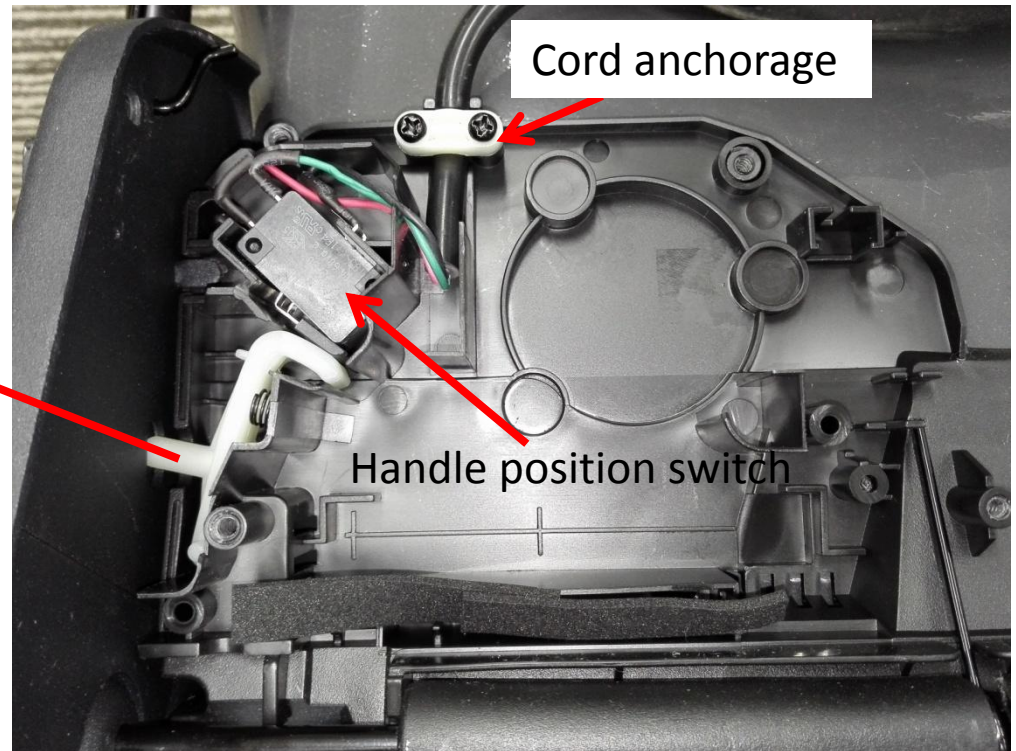

Cord anchorage

Handle position switch

Description	Part Number
Rotating Block	3126641001
Spring	3660076001
Cord Anchorage	3122798001

Handle position switch Replacement

LM2010E Lawn Mower

6. Remove the service cover to disconnect the wire linked with main PCB.
7. If the handle position switch is damaged, replace with a new one by re-soldering as shown in next slide.

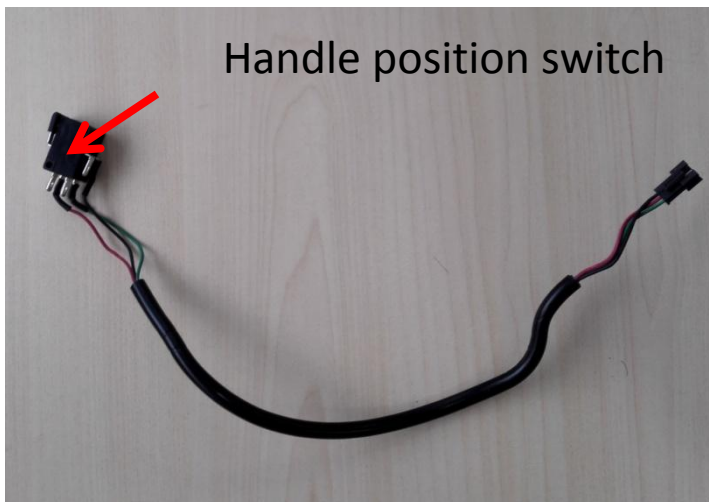
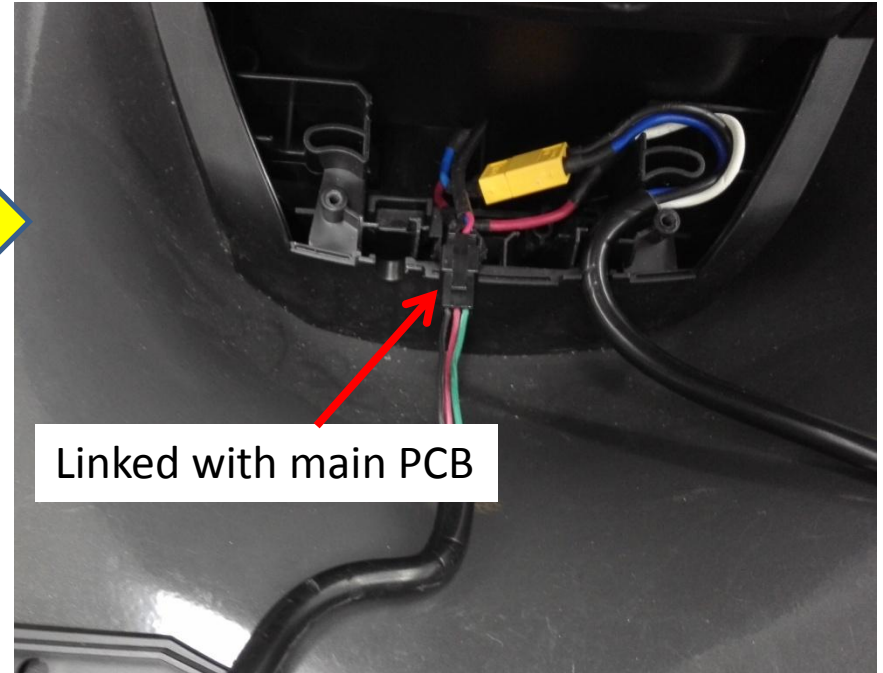

Description	Part Number
Handle Position Switch	4870541002

Handle position switch Replacement

LM2010E Lawn Mower

8. Test the handle position switch.

- Keep the trigger of the handle position switch depressed. Turn on the mower, the mower should be turned on properly.
- Leave the trigger undepressed, the mower should stop running.

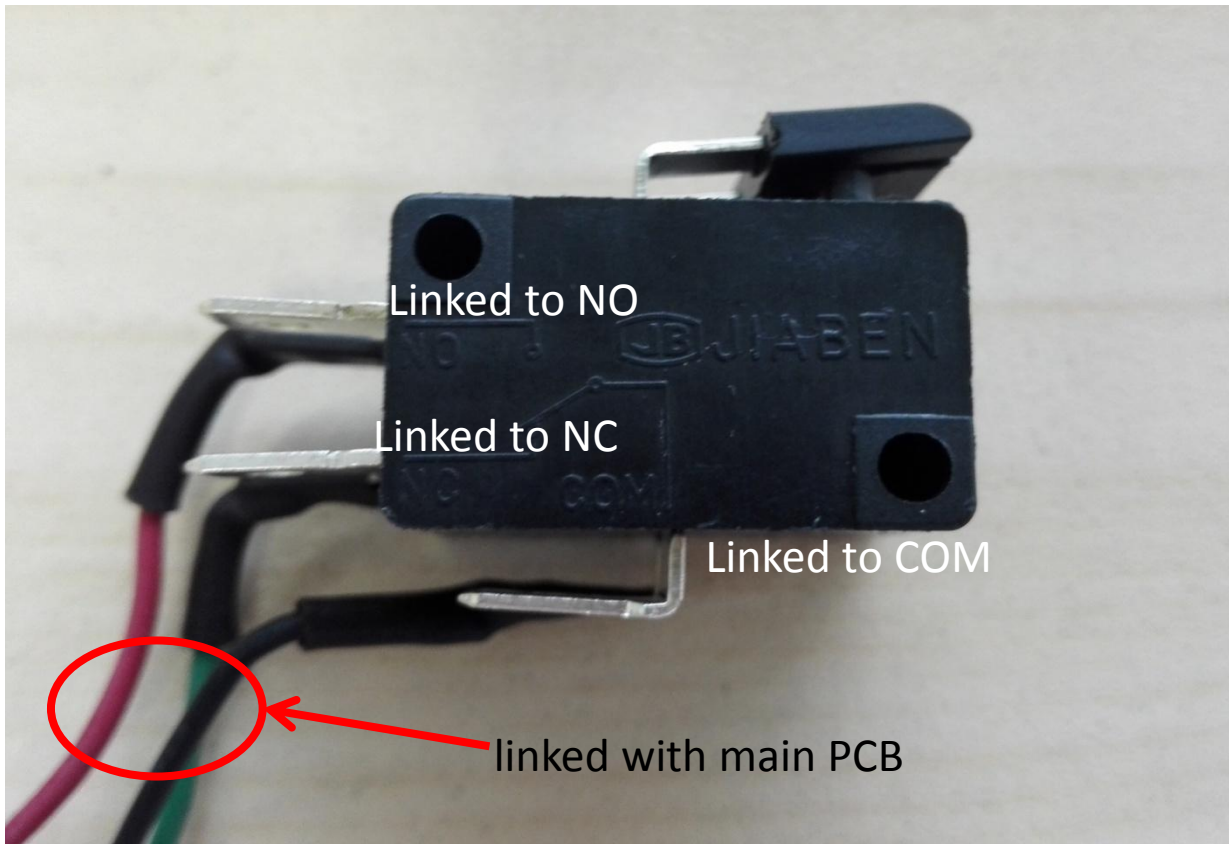

Handle position switch Replacement

LM2010E Lawn Mower

9. Mount the handle position switch, rotating block and wires into the grooves in housing cover and bottom cover.

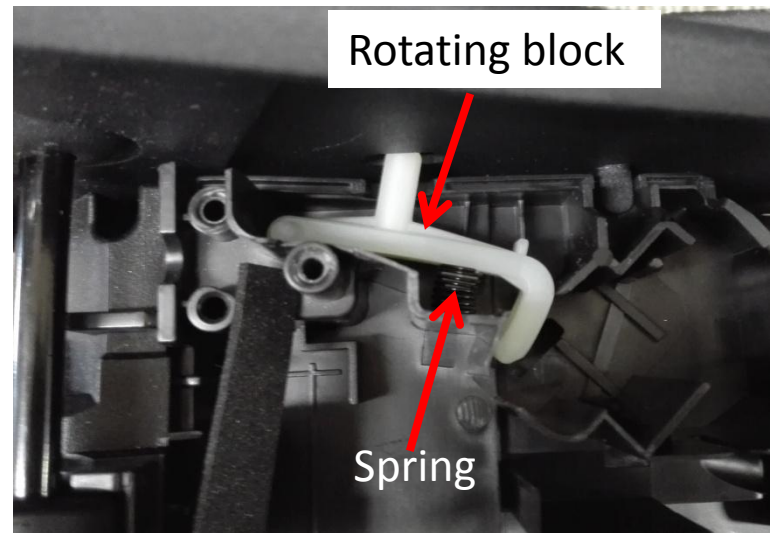
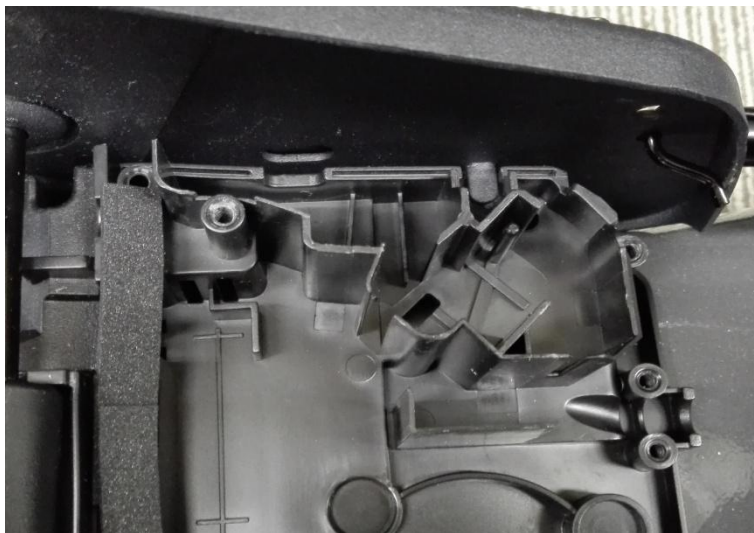
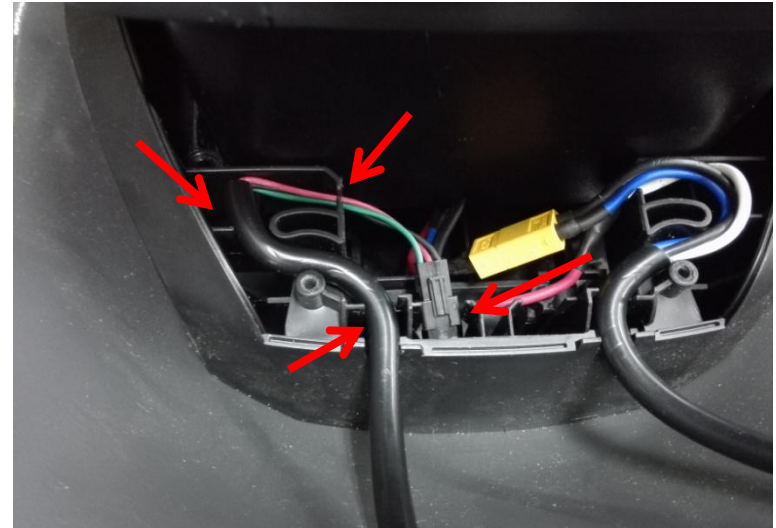
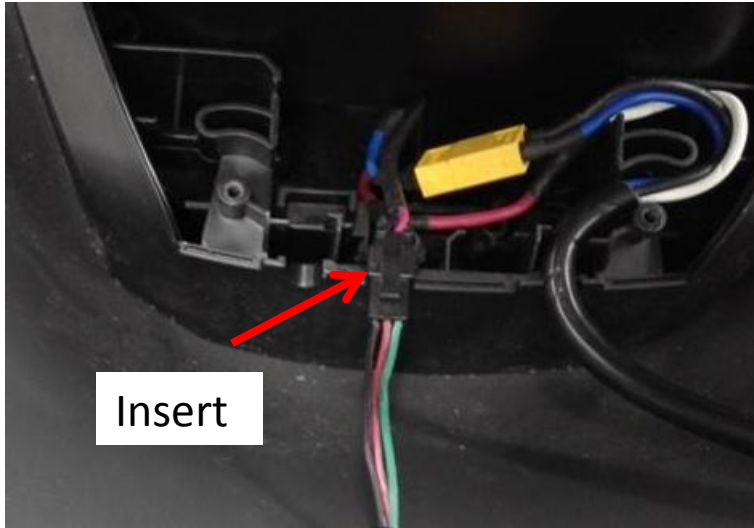

Handle position switch Replacement

LM2010E Lawn Mower

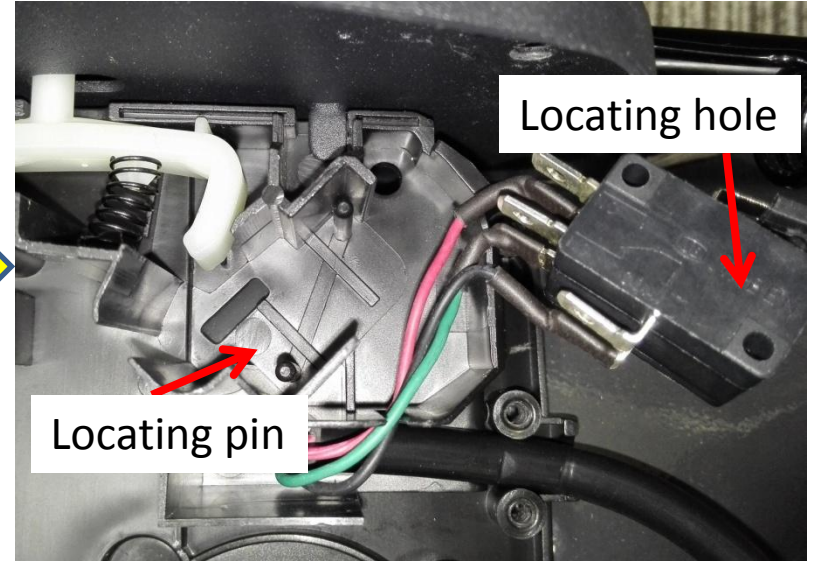
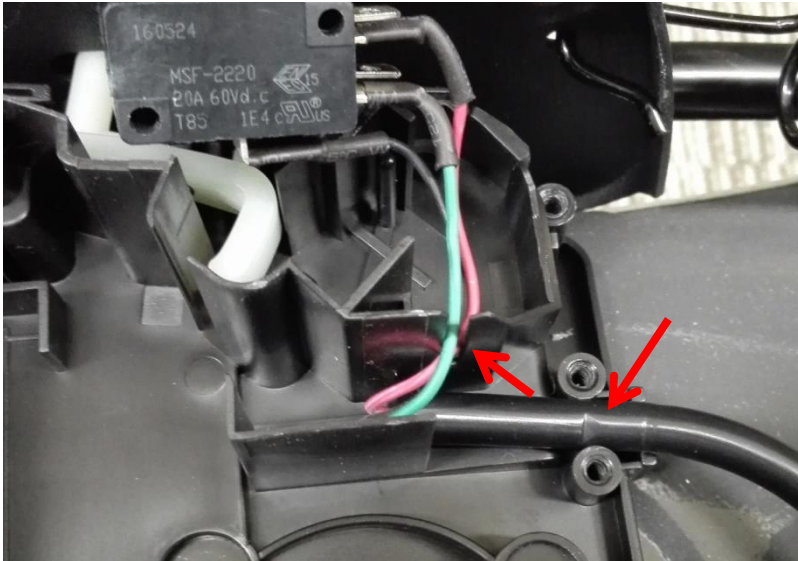

10. Fix the cord anchorage by tightening two screws.

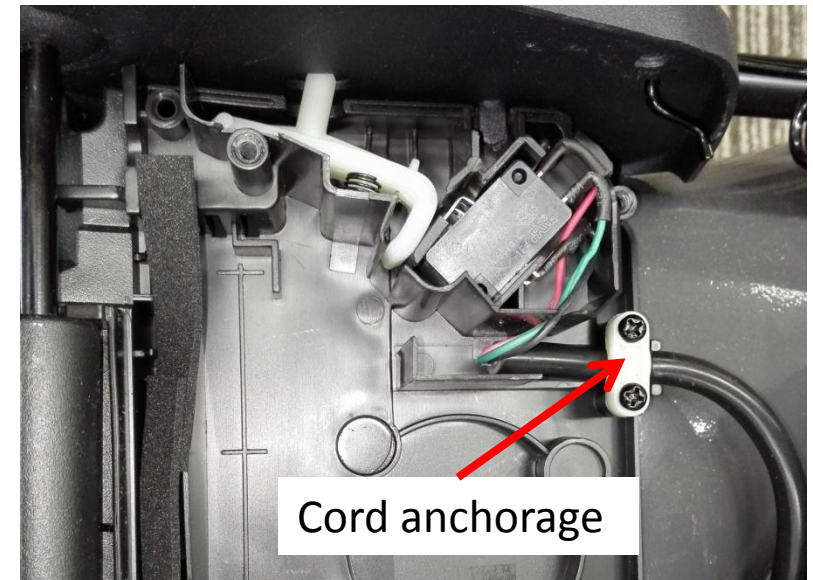

Handle position switch Replacement

LM2010E Lawn Mower

11. Mount the rear service cover, rear handle and service cover onto the mower.



THE END

REPAIR GUIDELINE

PART 9: Decorative Cover & Front Axle Replacement_LM2010E Lawn Mower



Table of Contents

LM2010E Lawn Mower

NO.	Contents	Page
1	Decorative Cover Replacement	3-4
2	Front Cover Set Replacement	5-6
3	Front Axle Replacement	7-11

1. Decorative Cover Replacement

1. Remove the blade(see Part 1).
2. Remove the power unit from the mower (see Part 3.1).
3. Turn the mower on its back to remove the 5 screws on the steel deck.

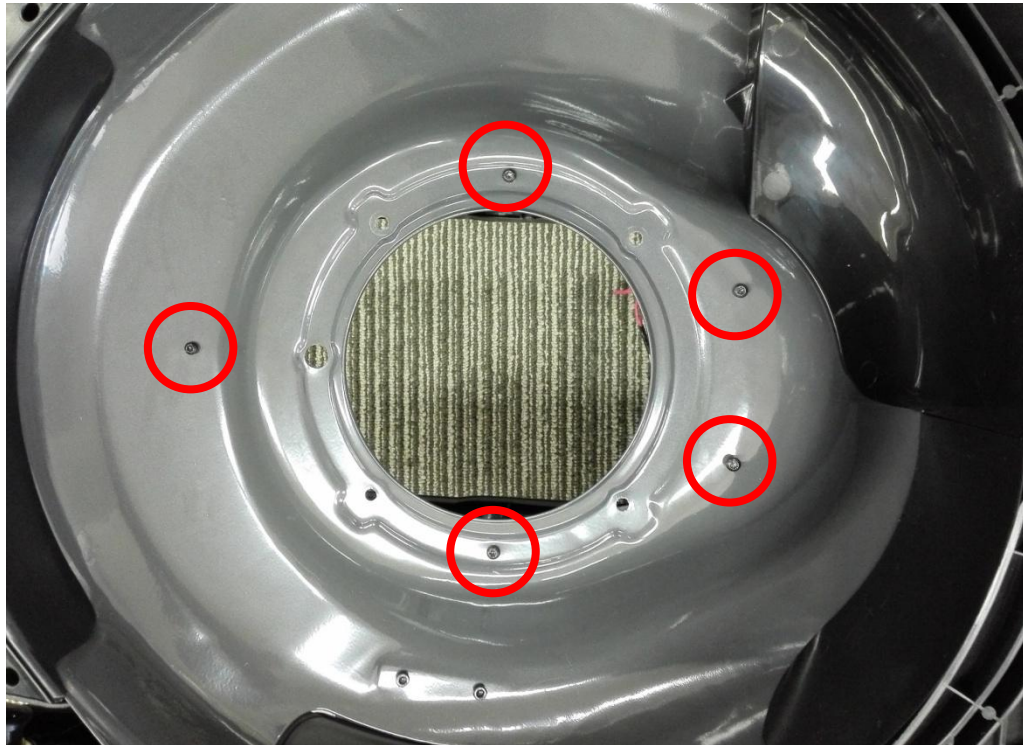

Description	Part Number	SPEC	Qty
Tapping screw	5620157006	M4.2x19	5

1. Decorative Cover Replacement

4. Remove the decorative cover from the mower.
5. If the decorative cover is damaged, replace it with a new one. Assemble the new one in reverse order.



Description	Part Number
Decorative Cover	3127951001

2. Front Cover Set Replacement

LM2010E Lawn Mower

1. Turn the mower on its back and remove the 5 screws to separate the lower front cover from the mower.
2. If the lower front cover is damaged, replace it with a new one.

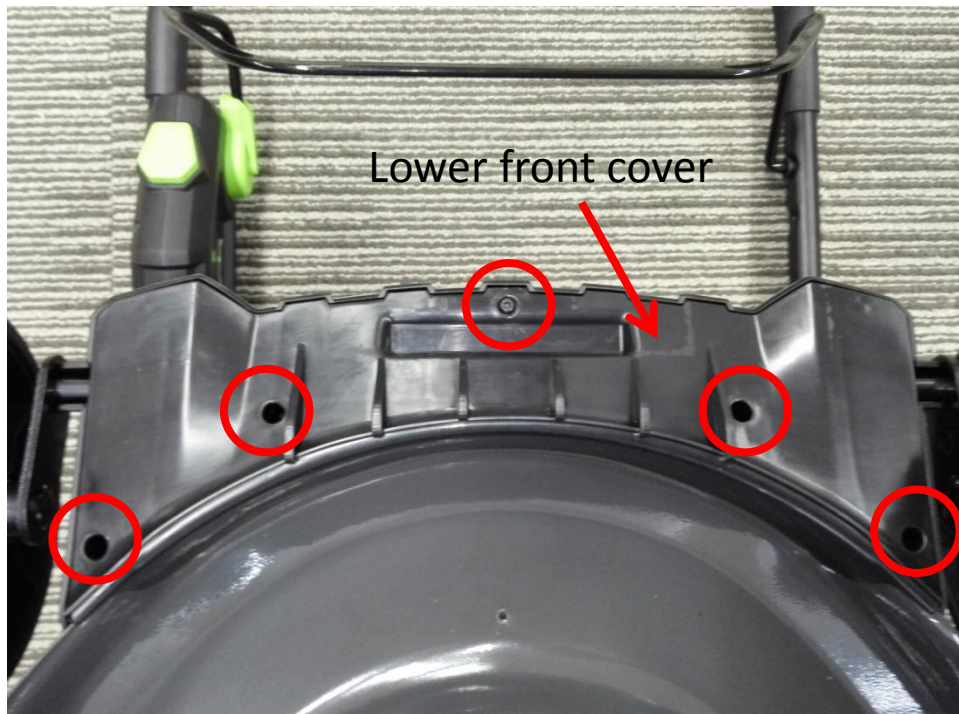

Description	Part Number
Lower Front Cover	3127963001
Upper Front Cover	3128060001
Front Cover ASSY	2824527001

2. Front Cover Set Replacement

3. Remove the 4 screws and take down the 2 mounting plates to separate the upper front cover from the mower.
4. If the upper front cover is damaged, replace it with a new one. Assemble the front cover set in reverse order.

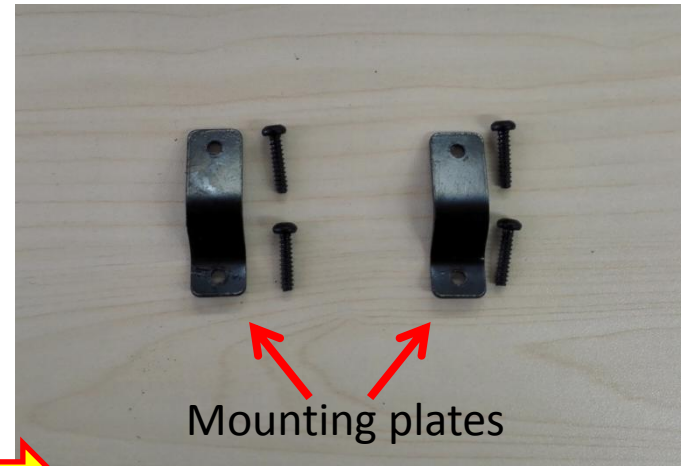
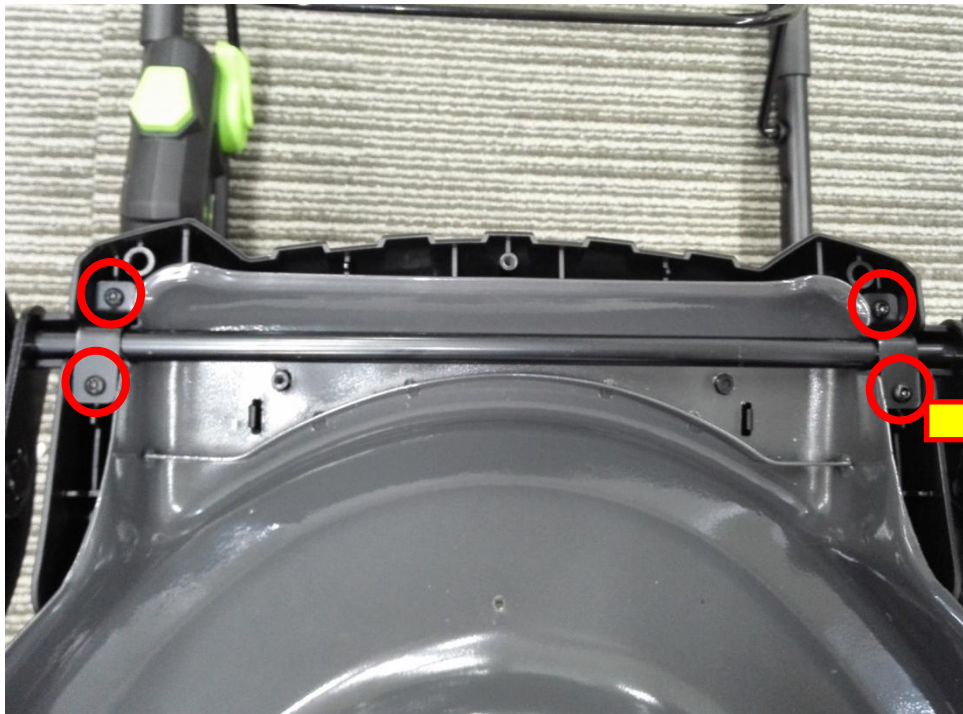

Description	Part Number	SPEC	Qty
Tapping screw	5620157006	M4.2x19	4
Mounting plate	3705216001	-	2

3. Front Axle Replacement

1. If the front axle is damaged, turn the mower on its back and disassemble the front wheels (see Part 6).

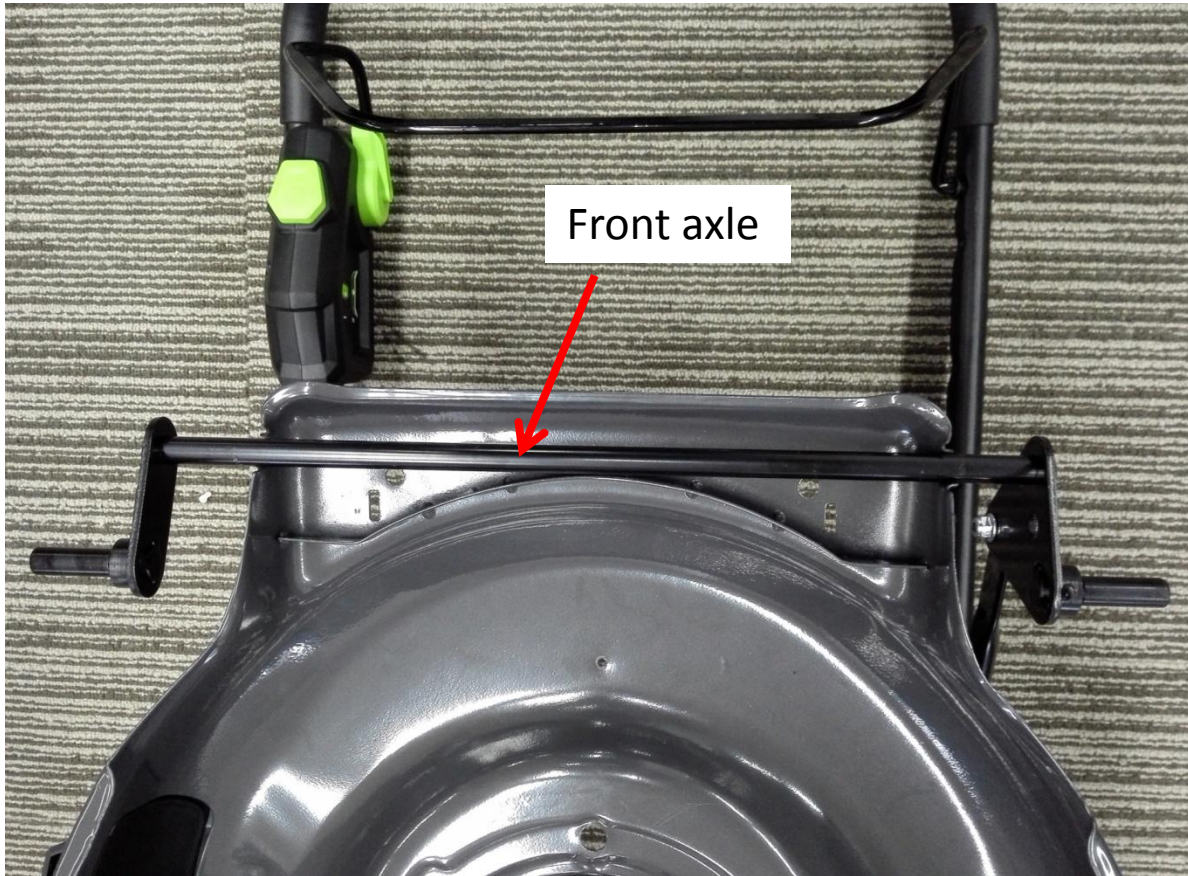

3. Front Axle Replacement

2. Remove the front cover set as previous steps show.



Front cover set +



3. Front Axle Replacement

- 3. Separate the front axle from the connecting rod by removing the prevailing torque hexagon nut on the joint. **WARNING:** This step is dangerous, slow down your operating speed.

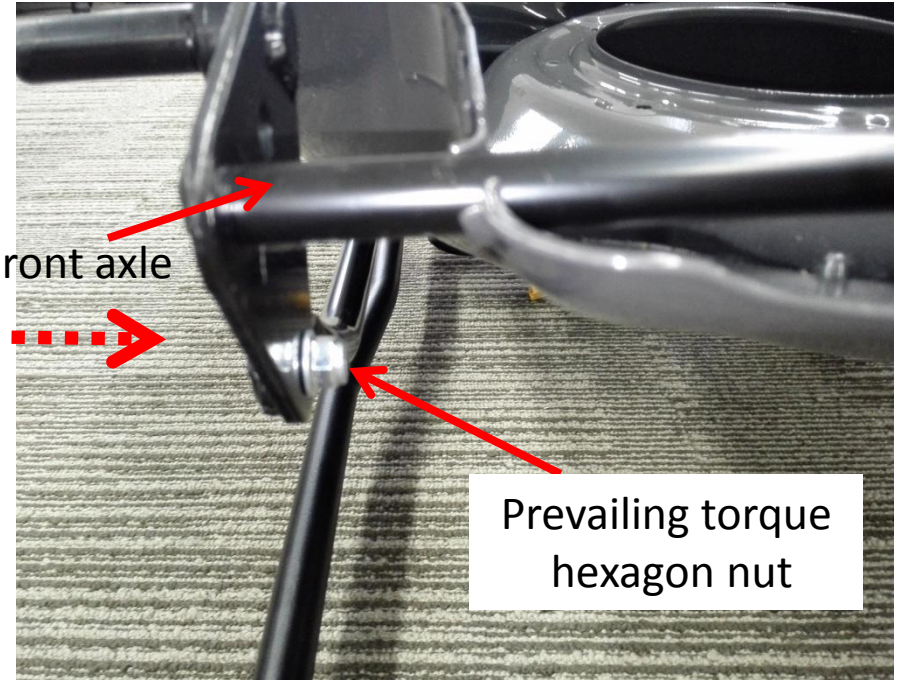
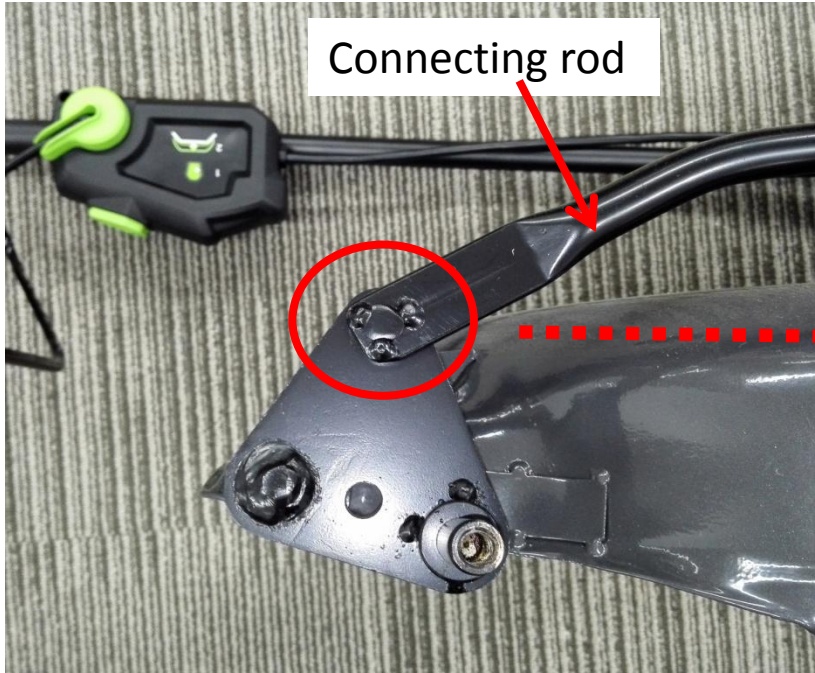

Description	Part Number	SPEC
Prevailing torque hexagon nut	5630013003	M6

3. Front Axle Replacement

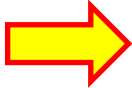

4. Take down the front axle from the mower.

Description	Part Number	SPEC	Qty
Front axle	2824348001	-	1

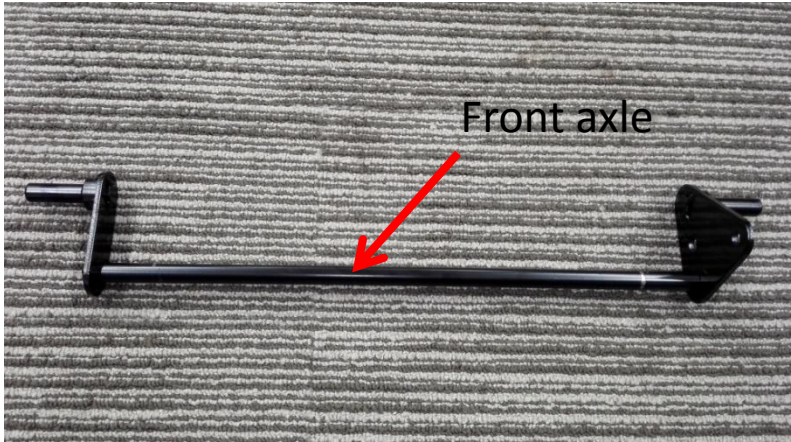

3. Front Axle Replacement

5. Replace the broken front axle with a new one.
6. Assemble it in reverse order.

THE END