

# PARTS LIST

## CHAIN SAW

**G455AVS**  
**G500AVS**

**NOTE :**

1. Use KOMATSU ZENOAH genuine parts specified in the parts list for repair and/or replacement.
2. KOMATSU ZENOAH does not warrant the machines, those which have been damaged by the use of any parts other than those specified by the company.
3. When placing orders of parts for repair and/or replacement, check if the model name and the serial number are suitable to those specified in the parts list, then use parts number described in the parts list.
4. The contents described in the parts list may change due to improvement.
5. The parts for the machine shall be supplied within ten (10) years after the machine is discontinued.  
[It is possible that some specific parts may be subject to change of their delivery term and list price within the limit of ten (10) years after the machine is discontinued. And it is also possible that some parts may be available even after the limit of ten (10) years.]

**APPLICABLE SERIAL NUMBERS :**

G455AVS: 514001 and up  
G500AVS: 504001 and up

December 2004

**Fig.1 ENGINE BLOCK, MUFFLER**

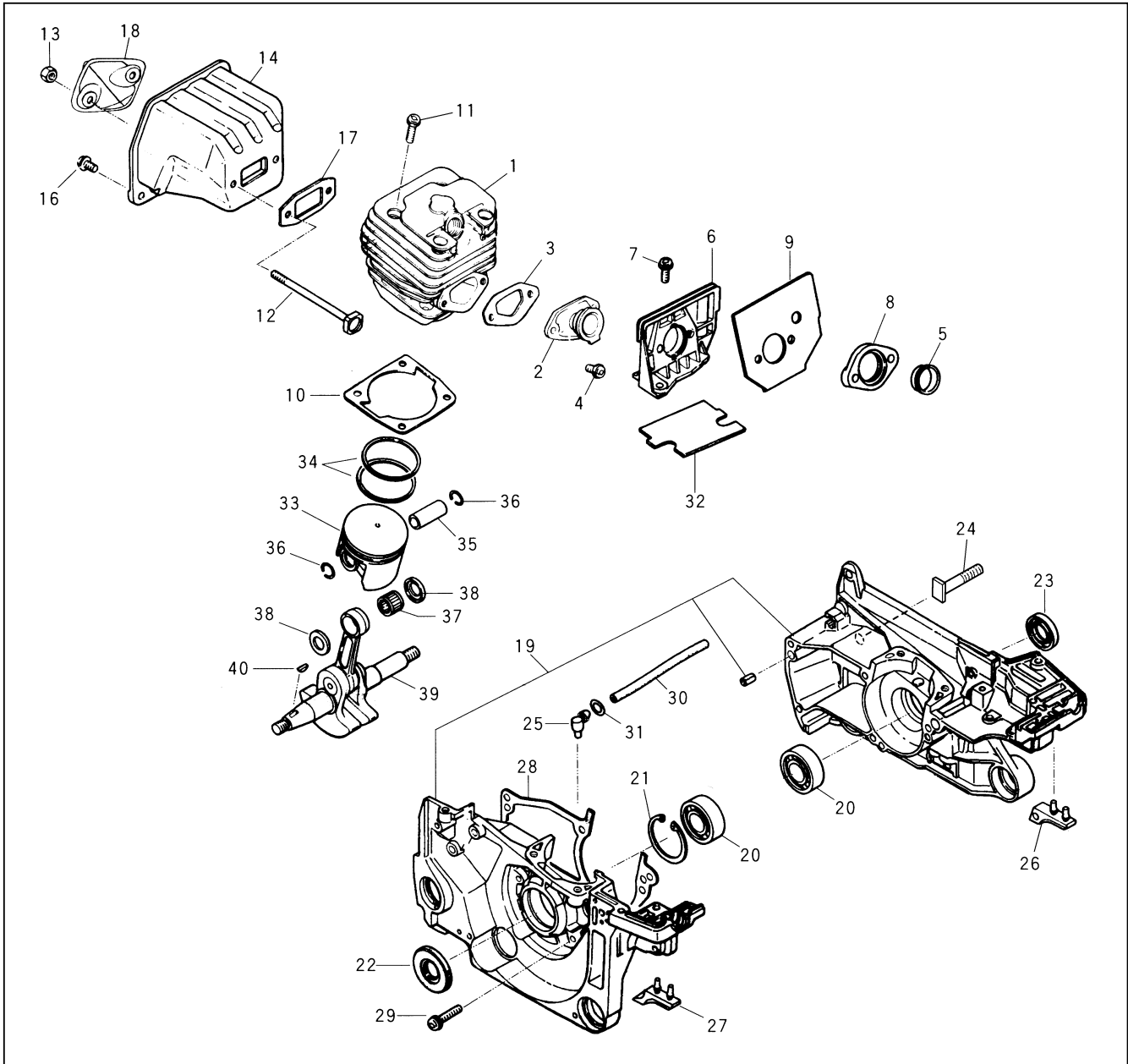

Key#	PART NUMBER	DESCRIPTION	Q'TY /UNIT	NOTE	Key#	PART NUMBER	DESCRIPTION	Q'TY /UNIT	NOTE
1	2670-12113	CYLINDER	1		24	2850-21230	BOLT	2	
2	2810-14110	INLET PIPE	1		25	2670-21250	ELBOW	1	
3	2817-14121	GASKET	1	*1	26	2810-22511	STOPPER	1	
4	2670-14130	SCREW	2		27	2810-22521	STOPPER	1	
5	2880-14150	GUIDE	1		28	848C8021D2	GASKET	1	*1
6	2670-14311	BRACKET	1		29	2670-21320	SCREW	5	
7	2670-14320	SCREW	2		30	2810-22210	PIPE	1	
8	2880-14350	SPACER	1		31	3310-82230	CLIP	1	
9	2880-14361	GASKET	1		32	2810-22411	MAT	1	
10	2670-14211	GASKET	1	*1	33	2670-41114	PISTON	1	
11	4820-13180	BOLT	4		34	2670-41211	RING	2	
12	2810-15220	BOLT	2		35	3350-41310	PIN	1	
13	2850-15230	NUT	2		36	3350-41320	SNAP RING	2	
14	2823-15114	MUFFLER	1		37	1400-41410	BEARING	1	
16	2670-14130	SCREW	2		38	2670-41510	WASHER	2	
17	3356-15210	GASKET	1	*1	39	848C804202	CRANKSHAFT COMP.	1	
18	2810-15310	COVER	1		40	1000-43240	KEY	1	
19	848C802101	CRANKCASE ASSY	1						
20	T4012-21240	BEARING	2						
21	04065-03515	SNAP RING	1						
22	2670-21210	SEAL	1						
23	2670-21220	SEAL	1						

\*1 Component of 2810-06012 GASKET KIT (Option)

**Fig.1 ENGINE BLOCK, MUFFLER**

**G500AVS**

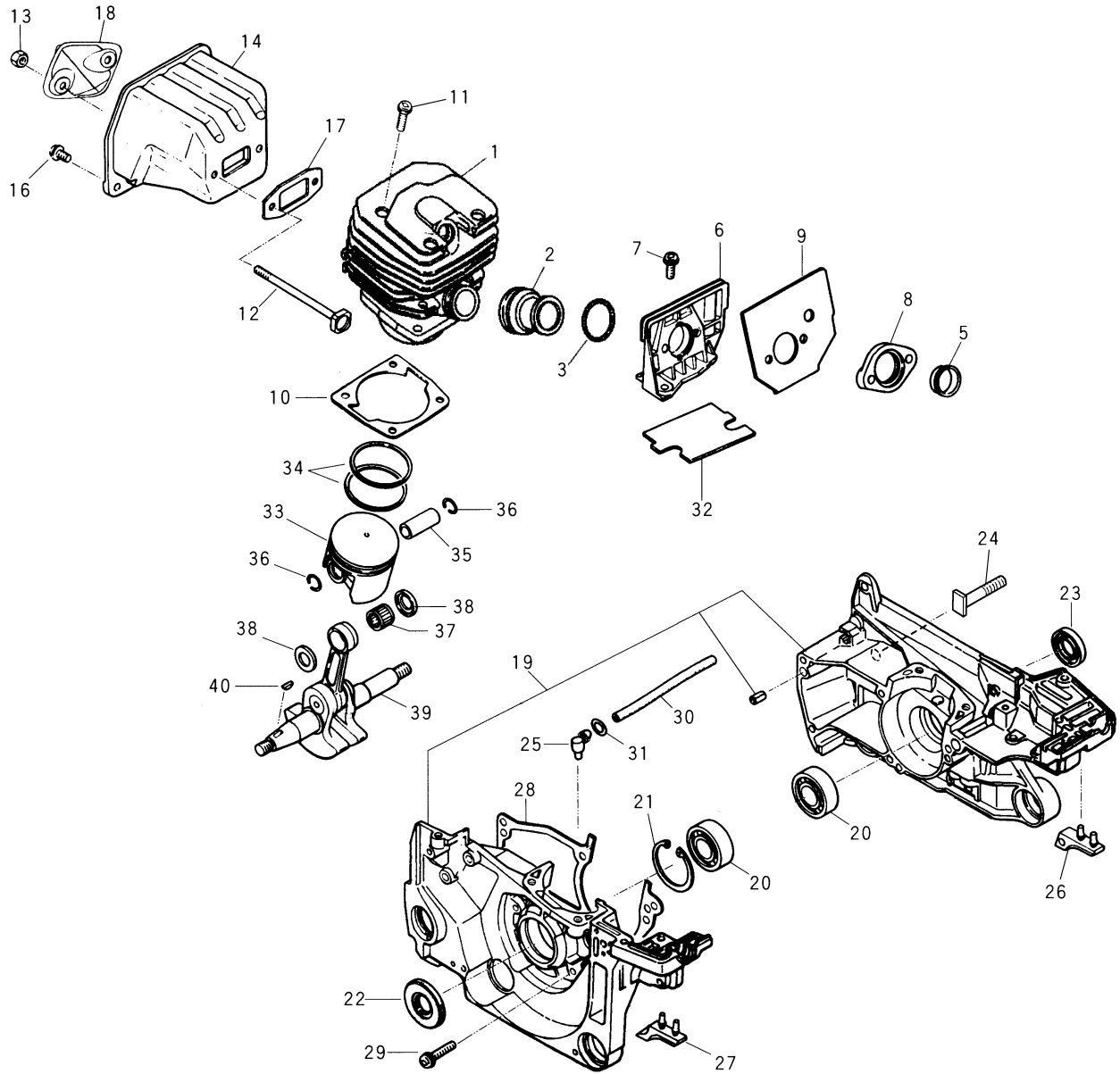

Key#	PART NUMBER	DESCRIPTION	Q'TY /UNIT	NOTE	Key#	PART NUMBER	DESCRIPTION	Q'TY /UNIT	NOTE
1	2880-12111	CYLINDER	1		24	2850-21230	BOLT	2	
2	2880-14111	PIPE	1		25	2670-21250	ELBOW	1	
3	2880-14120	SPRING	1		26	2810-22511	STOPPER	1	
5	2880-14150	GUIDE	1		27	2810-22521	STOPPER	1	
6	2670-14311	BRACKET	1		28	848C8021D2	GASKET	1	*1
7	2670-14320	SCREW	2		29	2670-21320	SCREW	5	
8	2880-14350	SPACER	1		30	2810-22210	PIPE	1	
9	2880-14361	GASKET	1		31	3310-82230	CLIP	1	
10	2670-14211	GASKET	1	*1	32	2810-22411	MAT	1	
11	4820-13180	BOLT	4		33	2880-41110	PISTON	1	
12	2810-15220	BOLT	2		34	2880-41210	RING	2	
13	2850-15230	NUT	2		35	2880-41310	PIN	1	
14	2823-15114	MUFFLER	1		36	3350-41320	SNAP RING	2	
16	2670-14130	SCREW	2		37	1400-41410	BEARING	1	
17	3356-15210	GASKET	1	*1	38	2670-41510	WASHER	2	
18	2810-15310	COVER	1		39	848C8A4202	CRANKSHAFT COMP.	1	
19	848C802101	CRANKCASE ASSY	1		40	1000-43240	KEY	1	
20	T4012-21240	BEARING	2						
21	04065-03515	SNAP RING	1						
22	2670-21210	SEAL	1						
23	2670-21220	SEAL	1						

\*1 Component of 2810-06012 GASKET KIT (Option)

**Fig.2 IGNITION SYSTEM, STARTER**

**G455AVS**

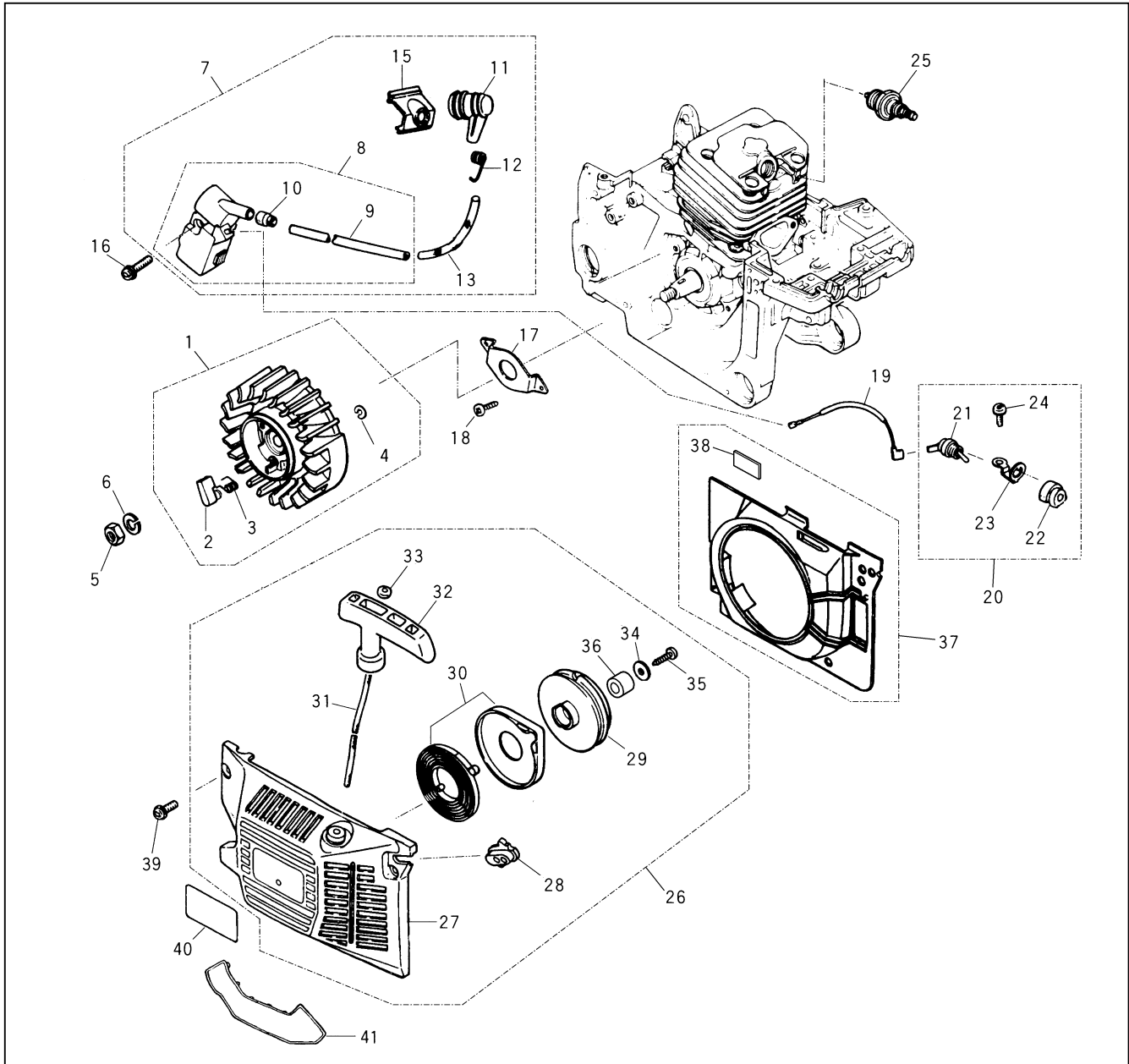

Key#	PART NUMBER	DESCRIPTION	Q'TY /UNIT	NOTE	Key#	PART NUMBER	DESCRIPTION	Q'TY /UNIT	NOTE
1	2670-71101	ROTOR ASSY	1		24	2670-14130	• SCREW	1	
2	1850-75220	• RATCHET	2		25	3699-90020-10	SPARK PLUG Champiopn	1	CJ7Y
3	2670-71130	• SPRING	2		26	2880-75003	STARTER ASSY	1	
4	0308-00040	• RING	2		27	2810-75110	• CASE	1	
5	3350-43231	NUT	1		28	2810-75120	• GUIDE	1	
6	0290-20820	WASHER	1		29	2670-75212	• REEL	1	
7	2880-71300	COIL ASSY	1		30	3317-75300	• SPRING COMP.	1	
8	2810-71204	• COIL COMP.	1		31	2670-75411	• ROPE	1	
9	2810-71220	•• CORD	1		32	1400-75170	• KNOB	1	
10	2670-71230	•• GROMMET	1		33	3310-75431	• WASHER	1	
11	2810-72110	•• CAP	1		34	1400-86280	• WASHER	1	
12	1400-72121	• SPRING	1		35	2670-14220	• SCREW	1	
13	2670-71320	• TUBE	1		36	2810-75150	• BOSS	1	
15	2810-71250	• GROMMET	1		37	2880-75600	COVER	1	
16	2670-14220	SCREW	2		38	2880-75620	• SEAT	1	
17	2810-21270	PLATE	1		39	2670-14320	SCREW	4	
18	0260-30410	SCREW	2		40	2810-75131	LABEL	1	
19	2670-71510	CORD	1		41	2881-98610	SNOW PROTECTOR	1	OPTION
20	2880-71600	SWITCH ASSY	1						
21	2810-71610	• SWITCH	1						
22	2670-71621	• COVER	1						
23	2880-71630	• PLATE	1						

**Fig.2 IGNITION SYSTEM, STARTER**

**G500AVS**

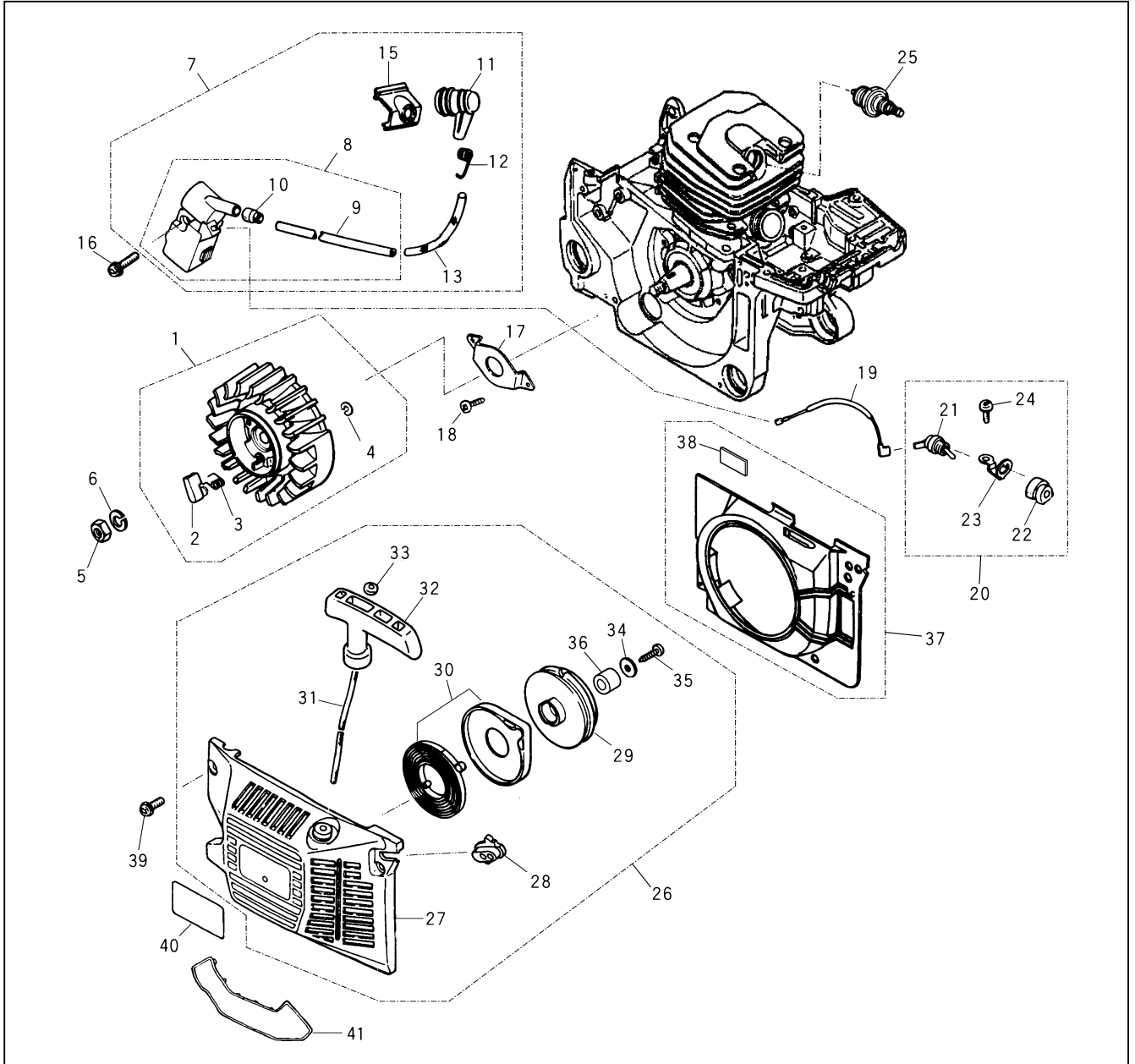

Key#	PART NUMBER	DESCRIPTION	Q'TY /UNIT	NOTE	Key#	PART NUMBER	DESCRIPTION	Q'TY /UNIT	NOTE
1	2670-71101	ROTOR ASSY	1		24	2670-14130	• SCREW	1	
2	1850-75220	• RATCHET	2		25	3699-90020-10	SPARK PLUG Champiopn	1	CJ6Y
3	2670-71130	• SPRING	2		26	2880-75003	STARTER ASSY	1	
4	0308-00040	• RING	2		27	2810-75110	• CASE	1	
5	3350-43231	NUT	1		28	2810-75120	• GUIDE	1	
6	0290-20820	WASHER	1		29	2670-75212	• REEL	1	
7	2880-71300	COIL ASSY	1		30	3317-75300	• SPRING COMP.	1	
8	2810-71204	• COIL COMP.	1		31	2670-75411	• ROPE	1	
9	2810-71220	•• CORD	1		32	1400-75170	• KNOB	1	
10	2670-71230	•• GROMMET	1		33	3310-75431	• WASHER	1	
11	2810-72110	• CAP	1		34	1400-86280	• WASHER	1	
12	1400-72121	• SPRING	1		35	2670-14220	• SCREW	1	
13	2670-71320	• TUBE	1		36	2810-75150	• BOSS	1	
15	2810-71250	• GROMMET	1		37	2880-75600	COVER	1	
16	2670-14220	SCREW	2		38	2880-75620	• SEAT	1	
17	2810-21270	PLATE	1		39	2670-14320	SCREW	4	
18	0260-30410	SCREW	2		40	2880-75131	LABEL	1	
19	2670-71510	CORD	1		41	2881-98610	SNOW PROTECTOR	1	OPTION
20	2880-71600	SWITCH ASSY	1						
21	2810-71610	• SWITCH	1						
22	2670-71621	• COVER	1						
23	2880-71630	• PLATE	1						

Fig.3 HANDLES

G455AVS

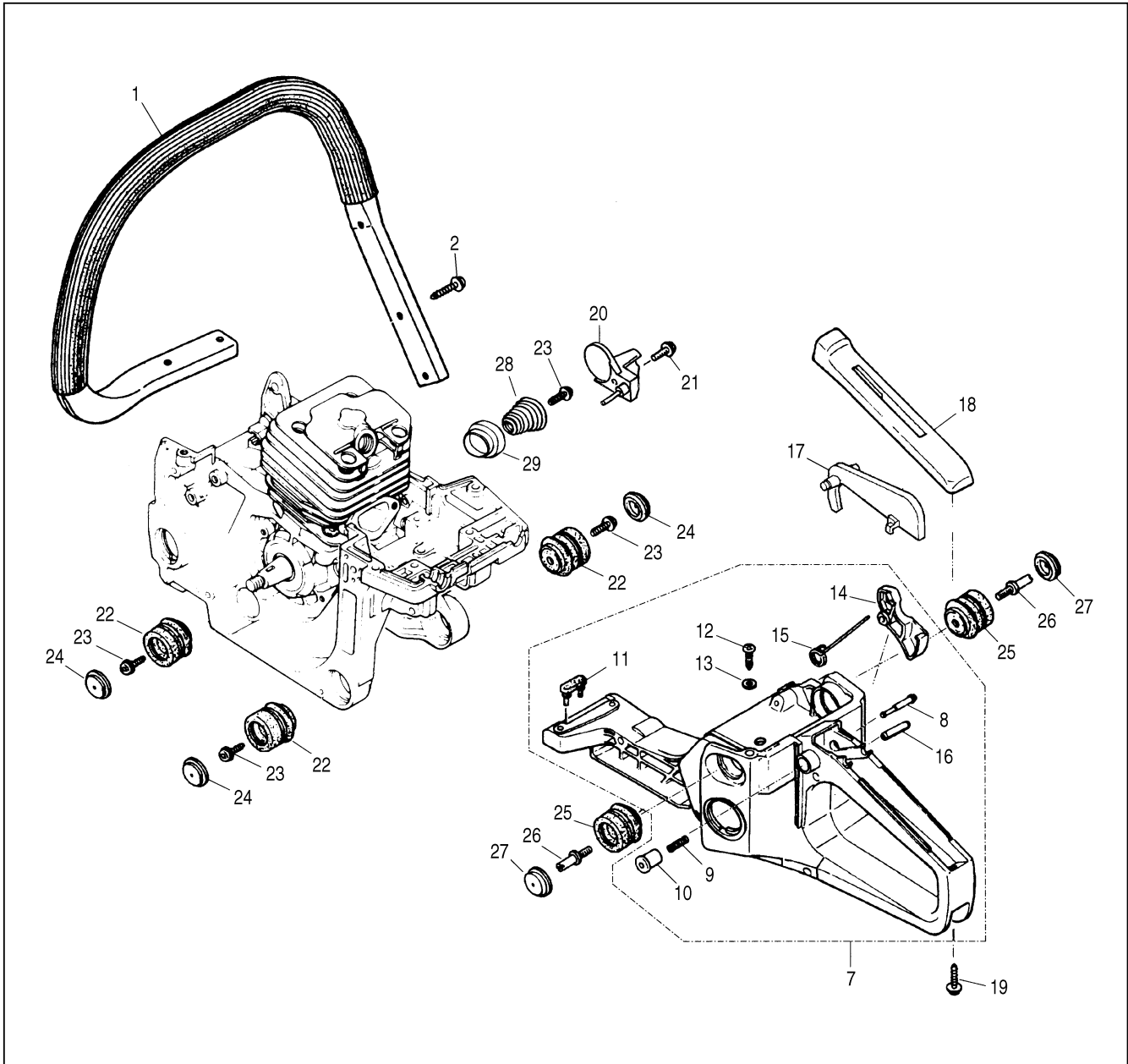

Key#	PART NUMBER	DESCRIPTION	Q'TY /UNIT	NOTE	Key#	PART NUMBER	DESCRIPTION	Q'TY /UNIT	NOTE
1	2880-32101	LEFT HANDLE COMP.	1		27	2880-35250	CAP	2	
2	8488251901	SCREW	4		28	2881-35110	SPRING	1	
7	2810-33007	HANDLE ASSY	1		29	2881-35120	SPACER	1	
8	3330-33250	• STOPPER	1						
9	3310-33262	• SPRING	1						
10	3310-33271	• KNOB	1						
11	2810-33280	• DAMPER (A)	1						
12	2670-75520	• SCREW	1						
13	2810-33211	• GASKET	1						
14	2670-33311	• LEVER	1						
15	3356-33321	• SPRING	1						
16	04025-00524	• SPRING PIN	1						
17	848C3033E3	ARM	1						
18	2670-34110	COVER	1						
19	8488251901	SCREW	1						
20	2810-25210	CHAIN CATCHER	1						
21	2670-14320	SCREW	1						
22	2880-35111	DAMPER	3						
23	8488251601	SCREW	4						
24	2810-35150	CAP	3						
25	2880-35211	DAMPER	2						
26	3350-35170	BOLT	2						

Fig.3 HANDLES

G500AVS

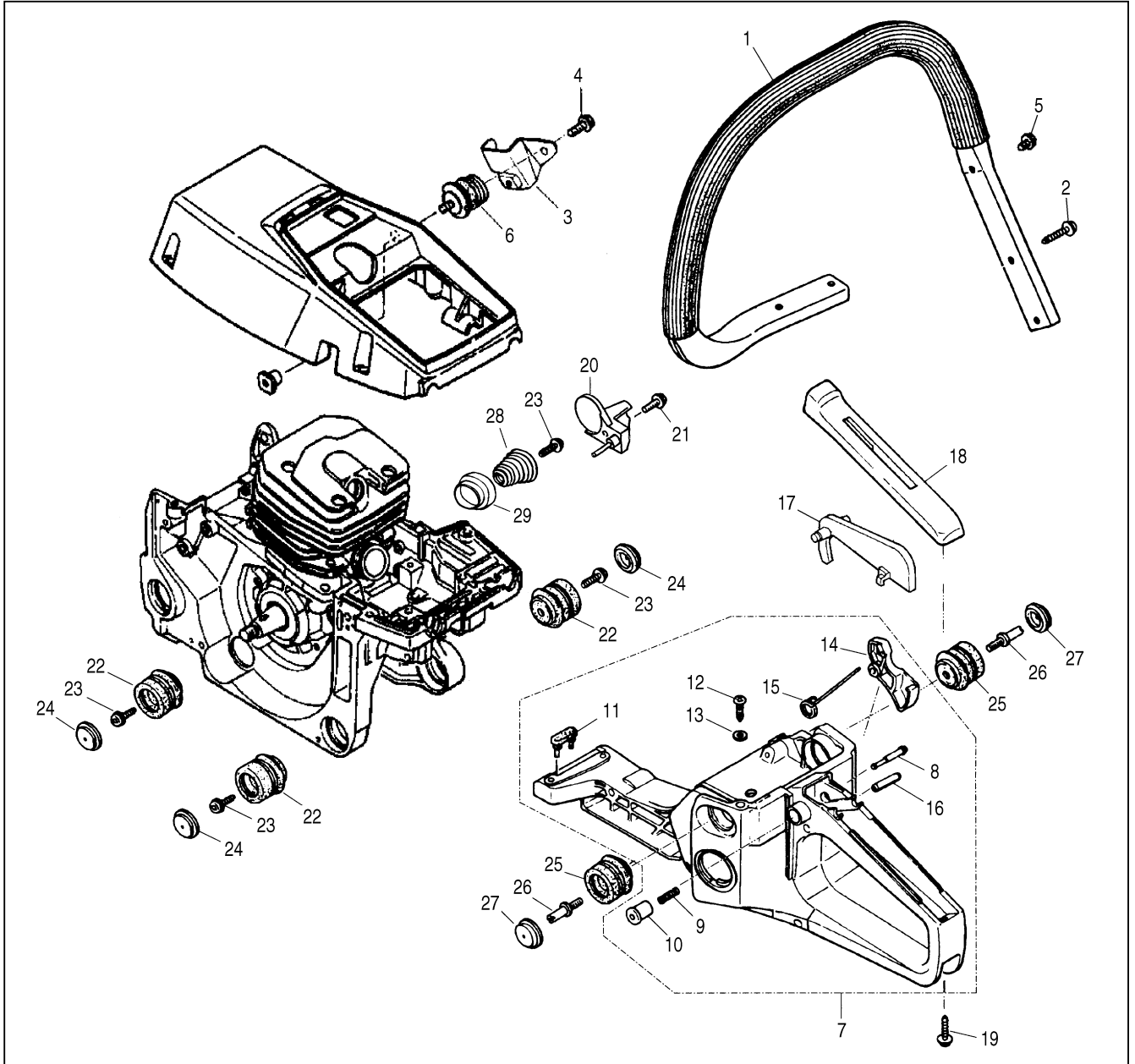

Key#	PART NUMBER	DESCRIPTION	Q'TY /UNIT	NOTE	Key#	PART NUMBER	DESCRIPTION	Q'TY /UNIT	NOTE
1	2880-32101	LEFT HANDLE COMP.	1		24	2810-35150	CAP	3	
2	8488251901	SCREW	4		25	2880-35211	DAMPER	2	
3	2880-32250	BRACKET	1		26	3350-35170	BOLT	2	
4	2670-14130	SCREW	1		27	2880-35250	CAP	2	
5	2880-32270	SCREW	1		28	2881-35110	SPRING	1	
6	2880-31211	DAMPER	1		29	2881-35120	SPACER	1	
7	2810-33007	HANDLE ASSY	1						
8	3330-33250	• STOPPER	1						
9	3310-33262	• SPRING	1						
10	3310-33271	• KNOB	1						
11	2810-33280	• DAMPER (A)	1						
12	2670-75520	• SCREW	1						
13	2810-33211	• GASKET	1						
14	2670-33311	• LEVER	1						
15	3356-33321	• SPRING	1						
16	04025-00524	• SPRING PIN	1						
17	848C3033E3	ARM	1						
18	2670-34110	COVER	1						
19	8488251901	SCREW	1						
20	2810-25210	CHAIN CATCHER	1						
21	2670-14320	SCREW	1						
22	2880-35111	DAMPER	3						
23	8488251601	SCREW	4						

**Fig.4 FUEL SUPPLY SYSTEM**

**G455AVS**

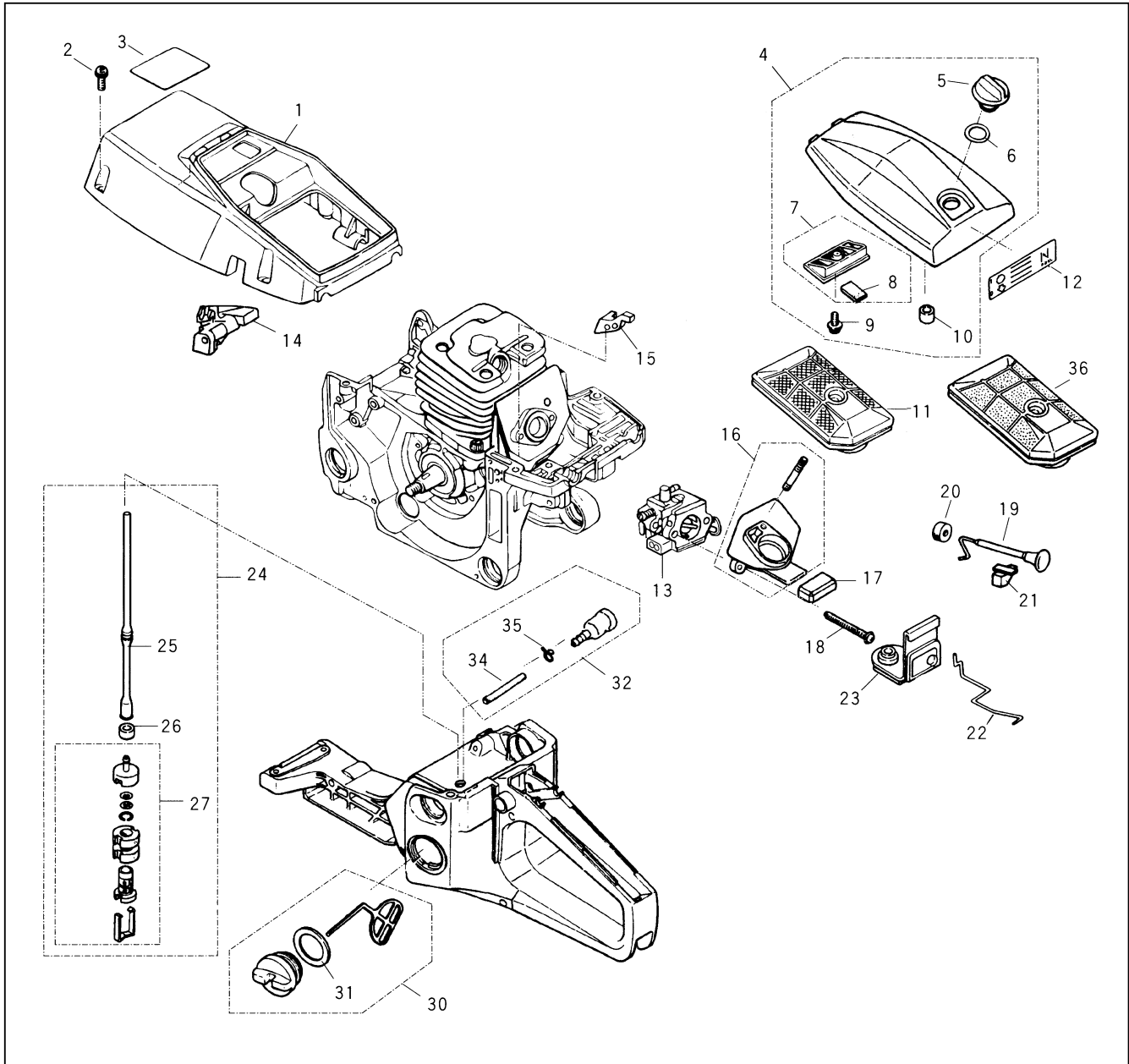

Key#	PART NUMBER	DESCRIPTION	Q'TY /UNIT	NOTE	Key#	PART NUMBER	DESCRIPTION	Q'TY /UNIT	NOTE
1	2810-31115	CYLINDER COVER	1		24	848C808535	FUEL PIPE ASSY	1	
2	2670-14320	SCREW	5		25	848C8085R4	• PIPE	1	
3	2813-31420	LABEL	1		26	2850-34350	• COLLAR	1	
4	2810-83305	CLEANER COVER COMP.	1		27	3302-85400	• FILTER ASSY	1	
5	3356-83322	• KNOB	1		30	2670-34401	TANK CAP ASSY	1	
6	3388-83340	• GASKET	1		31	2670-34430	• GASKET	1	
7	2810-83500	• CLEANER COMP.	1		32	2670-34500	BREATHER ASSY	1	
8	2810-83520	•• SEAL	1		34	3350-34540	• PIPE	1	
9	1600-33130	• SCREW	1		35	1260-85460	• CLIP	1	
10	2810-83410	• GROMMET	1		36	2811-98501	CLEANER COMP.	1	OPTION
11	2810-83101	CLEANER COMP.	1						
12	2813-31210	LABEL	1						
13	848C818103	CARBURETOR ASSY	1						
14	2880-82310	GUIDE (L)	1						
15	2880-82350	GUIDE (HL)	1						
16	2880-82102	MANIFOLD COMP.	1						
17	2810-82141	SUPPORTER	1						
18	2880-82210	SCREW	2						
19	2880-82410	CHOKE ROD	1						
20	2670-82421	GROMMET	1						
21	2670-82430	GUIDE	1						
22	2880-82511	THROTTLE ROD	1						
23	2810-82520	GROMMET	1						



**Fig.4 FUEL SUPPLY SYSTEM**

**G500AVS**

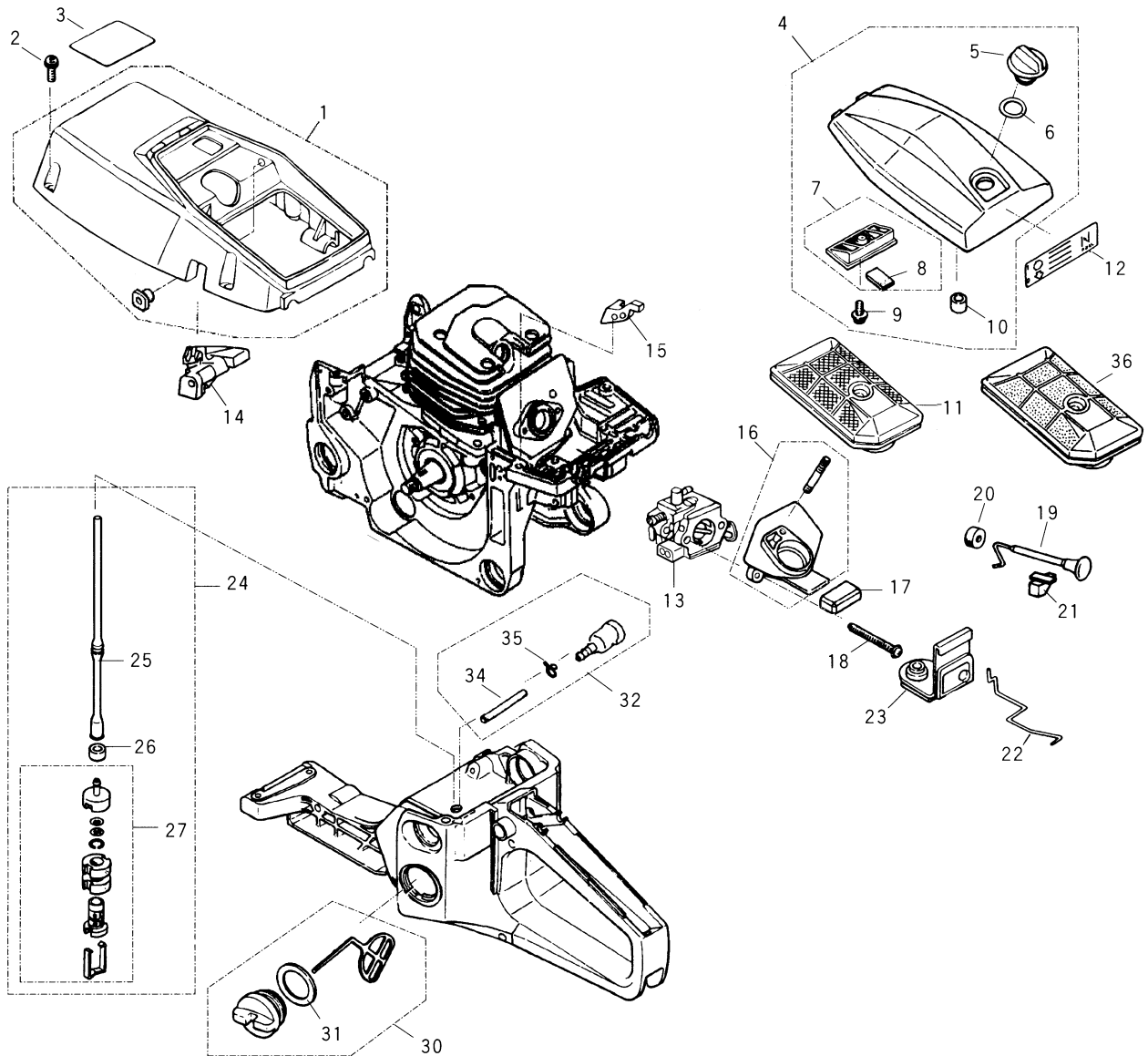

Key#	PART NUMBER	DESCRIPTION	Q'TY /UNIT	NOTE	Key#	PART NUMBER	DESCRIPTION	Q'TY /UNIT	NOTE
1	2880-31101	CYLINDER COVER COMP.	1		24	848C808535	FUEL PIPE ASSY	1	
2	2670-14320	SCREW	5		25	848C8085R4	• PIPE	1	
3	2883-31420	LABEL	1		26	2850-34350	• COLLAR	1	
4	2810-83305	CLEANER COVER COMP.	1		27	3302-85400	• FILTER ASSY	1	
5	3356-83322	• KNOB	1						
6	3388-83340	• GASKET	1		30	2670-34401	TANK CAP ASSY	1	
7	2810-83500	• CLEANER COMP.	1		31	2670-34430	• GASKET	1	
8	2810-83520	•• SEAL	1		32	2670-34500	BREATHER ASSY	1	
9	1600-33130	• SCREW	1						
10	2810-83410	• GROMMET	1		34	3350-34540	• PIPE	1	
11	2810-83101	CLEANER COMP.	1		35	1260-85460	• CLIP	1	
12	2813-31210	LABEL	1		36	2811-98501	CLEANER COMP.	1	OPTION
13	848C8E8102	CARBURETOR ASSY	1						
14	2880-82310	GUIDE (L)	1						
15	2880-82350	GUIDE (HL)	1						
16	2880-82102	MANIFOLD COMP.	1						
17	2810-82141	SUPPORTER	1						
18	2880-82210	SCREW	2						
19	2880-82410	CHOKE ROD	1						
20	2670-82421	GROMMET	1						
21	2670-82430	GUIDE	1						
22	2880-82511	THROTTLE ROD	1						
23	2810-82520	GROMMET	1						

Fig.5 OIL FEED SYSTEM, CLUTCH,

G455AVS

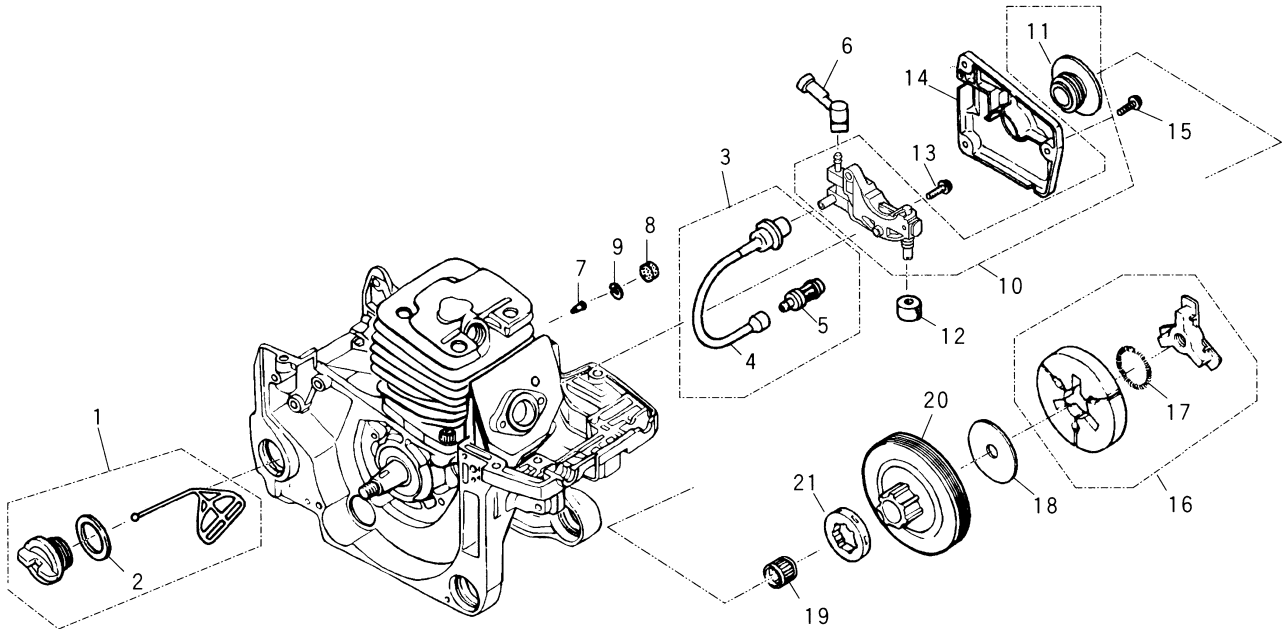

Key#	PART NUMBER	DESCRIPTION	Q'TY /UNIT	NOTE	Key#	PART NUMBER	DESCRIPTION	Q'TY /UNIT	NOTE
1	2841-31801	CAP ASSY	1						
2	2841-31820	• GASKET	1						
3	2670-23101	OIL PIPE ASSY	1						
4	2670-23120	• PIPE	1						
5	2670-23131	• FILTER	1						
6	2670-23210	PIPE	1						
7	3330-23121	VALVE	1						
8	3350-26220	SEAL	1						
9	3350-26230	CLIP	1						
10	848C806711	OIL PUMP ASSY	1						
11	2670-55120	• GEAR	1						
12	2670-55220	SEAL	1						
13	2670-55410	SCREW	2						
14	2670-55610	COVER	1						
15	2670-55410	SCREW	3						
16	848C805121	CLUTCH ASSY	1						
17	3317-51231	• SPRING	1						
18	2670-51210	PLATE	1						
19	2810-51310	BEARING	1						
20	2880-51110	DRUM	1						
21	3350-51121	RIM	1						

Fig.5 OIL FEED SYSTEM, CLUTCH,

G500AVS

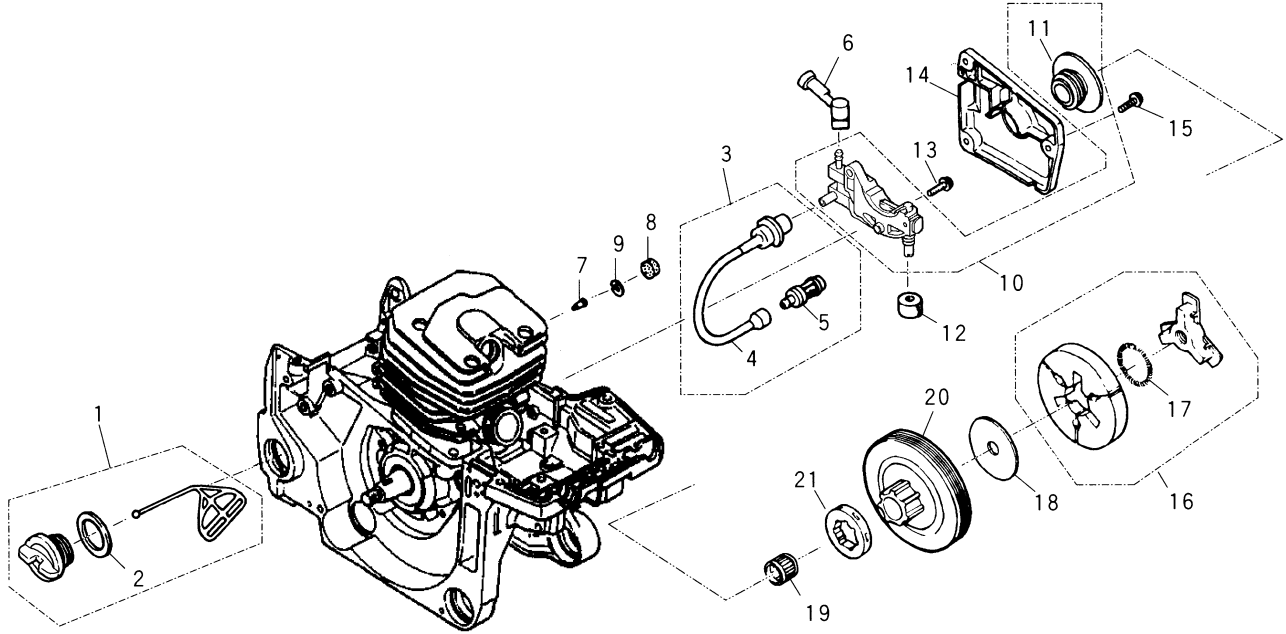

Key#	PART NUMBER	DESCRIPTION	Q'TY /UNIT	NOTE	Key#	PART NUMBER	DESCRIPTION	Q'TY /UNIT	NOTE
1	2841-31801	CAP ASSY	1						
2	2841-31820	• GASKET	1						
3	2670-23101	OIL PIPE ASSY	1						
4	2670-23120	• PIPE	1						
5	2670-23131	• FILTER	1						
6	2670-23210	PIPE	1						
7	3330-23121	VALVE	1						
8	3350-26220	SEAL	1						
9	3350-26230	CLIP	1						
10	848C806711	OIL PUMP ASSY	1						
11	2670-55120	• GEAR	1						
12	2670-55220	SEAL	1						
13	2670-55410	SCREW	2						
14	2670-55610	COVER	1						
15	2670-55410	SCREW	3						
16	848C805121	CLUTCH ASSY	1						
17	3317-51231	• SPRING	1						
18	2670-51210	PLATE	1						
19	2810-51310	BEARING	1						
20	2880-51110	DRUM	1						
21	3350-51121	RIM	1						

Fig.6 CARBURETOR

G455AVS

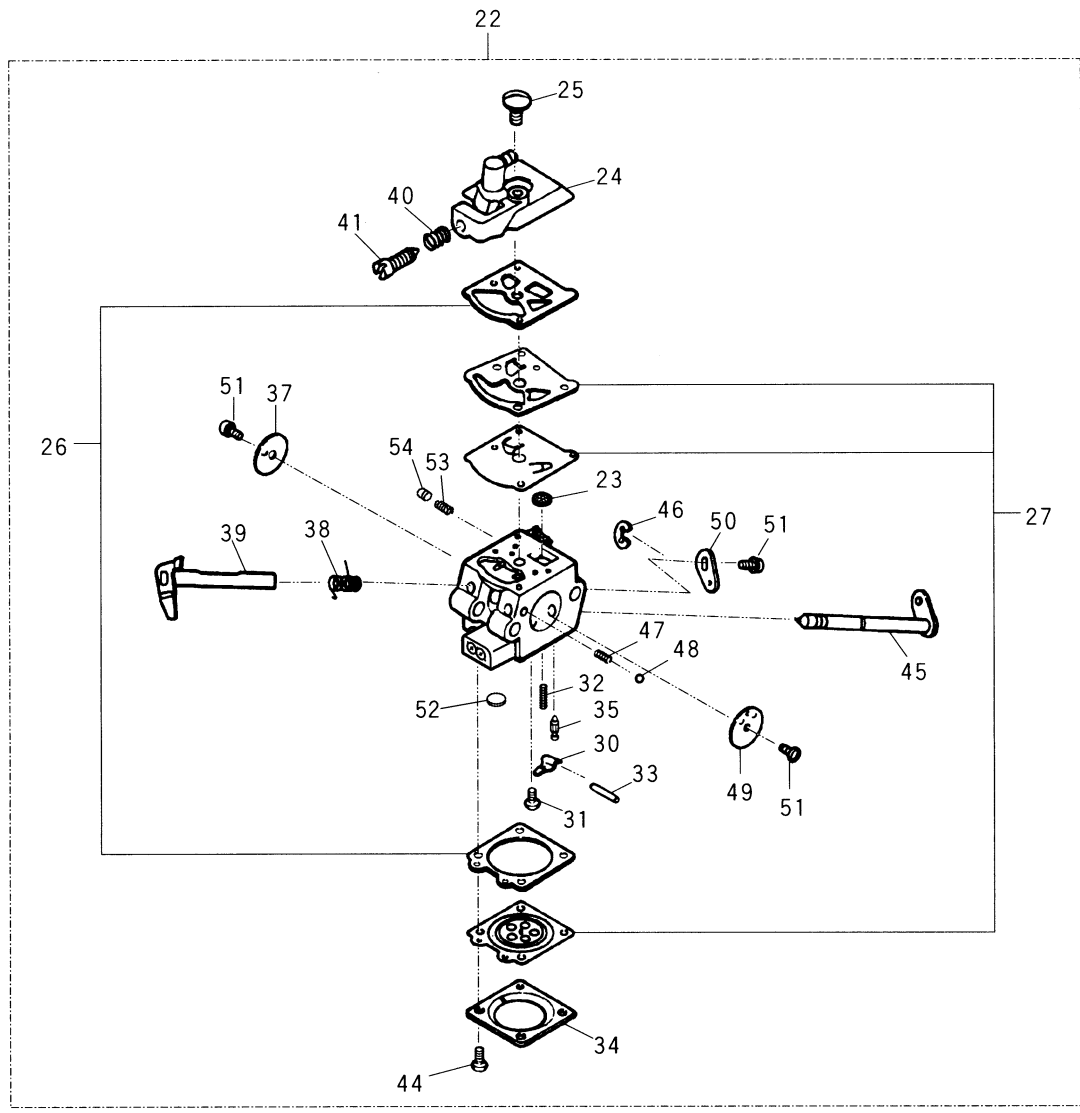

Key#	PART NUMBER	DESCRIPTION	Q'TY /UNIT	NOTE	Key#	PART NUMBER	DESCRIPTION	Q'TY /UNIT	NOTE
22	848C818103	CARBURETOR ASSY	1		47	3350-81350	• SPRING	1	
23	3306-81380	• SCREEN	1	]1	48	3350-81220	• BALL	1	
24	2810-81120	• COVER	1		49	2670-81450	• CHOKE VALVE	1	
25	3310-81130	• SCREW	1		50	2810-81440	• LEVER	1	
26	3304-81910	• GASKET KIT	1	]1	51	2880-81470	• SCREW	3	
27	2810-06041	• DIAPHRAGM KIT	1	]1	52	1480-81420	• PLUG	1	
30	3310-81230	• LEVER	1	]1	53	2810-81530	• SPRING	1	
31	3310-81240	• SCREW	1		54	848C7180N0	• PISTON	1	
32	2841-81270	• SPRING	1	]1					
33	3310-81250	• PIN	1	]1					
34	3310-81280	• COVER	1						
35	3356-81310	• INLET VALVE	1	]1					
37	3356-81340	• THROTTLE VALVE	1						
38	2670-81410	• SPRING	1						
39	848C8181T0	• THROTTLE SHAFT	1						
40	2630-81460	• SPRING	1						
41	2670-81430	• SCREW	1						
44	3310-81351	• SCREW	4						
45	2880-81460	• CHOKE SHAFT	1						
46	1148-81390	• RING	1						

\*1 Component of 2810-06030 REPAIR KIT (Optional)

**Fig.6 CARBURETOR**

**G500AVS**

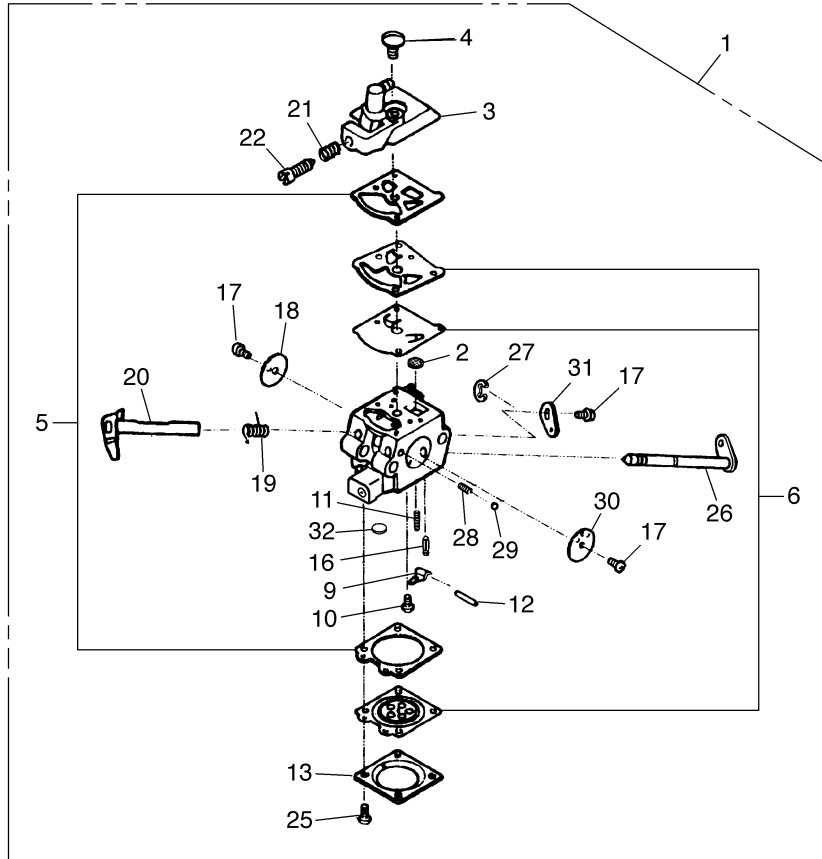

Key#	PART NUMBER	DESCRIPTION	Q'TY /UNIT	NOTE	Key#	PART NUMBER	DESCRIPTION	Q'TY /UNIT	NOTE
1	848C8E8102	CARBURETOR ASSY	1	WT-755	27	1148-81390	• RING	1	
2	3306-81380	• SCREEN	1		28	3350-81350	• CHOKE SPRING	1	
3	2810-81120	• PUMP COVER	1		29	3350-81220	• BOLL	1	
4	3310-81130	• SCREW	1		30	2670-81450	• CHOKE VALVE	1	
5	3304-81910	• GASKET KIT	1		31	2810-81440	• THROTTLE LEVER	1	
6	2810-06041	• DIAPHRAGM KIT	1		32	1480-81420	• PLUG	1	
9	3310-81230	• LEVER	1						
10	3310-81240	• SCREW M LEVER PIN	1						
11	2841-81270	• SPRING	1						
12	3310-81250	• PIN, lever	1						
13	3310-81280	• COVER	1						
16	3356-81310	• VALVE, inlet	1						
17	2880-81470	• SCREW, valve	3						
18	3356-81340	• THROTTLE valve	1						
19	2670-81410	• THROTTLE SPRING	1						
20	T2108-81370	• THROTTLE SHAFT	1						
21	2630-81460	• IDLE SPRING	1						
22	2670-81430	• IDLE SCREW	1						
25	3310-81351	• SCREW	4						
26	2880-81460	• CHOKE SHAFT	1						

Fig.7 BAR MOUNT, CHAIN BRAKE

G455AVS

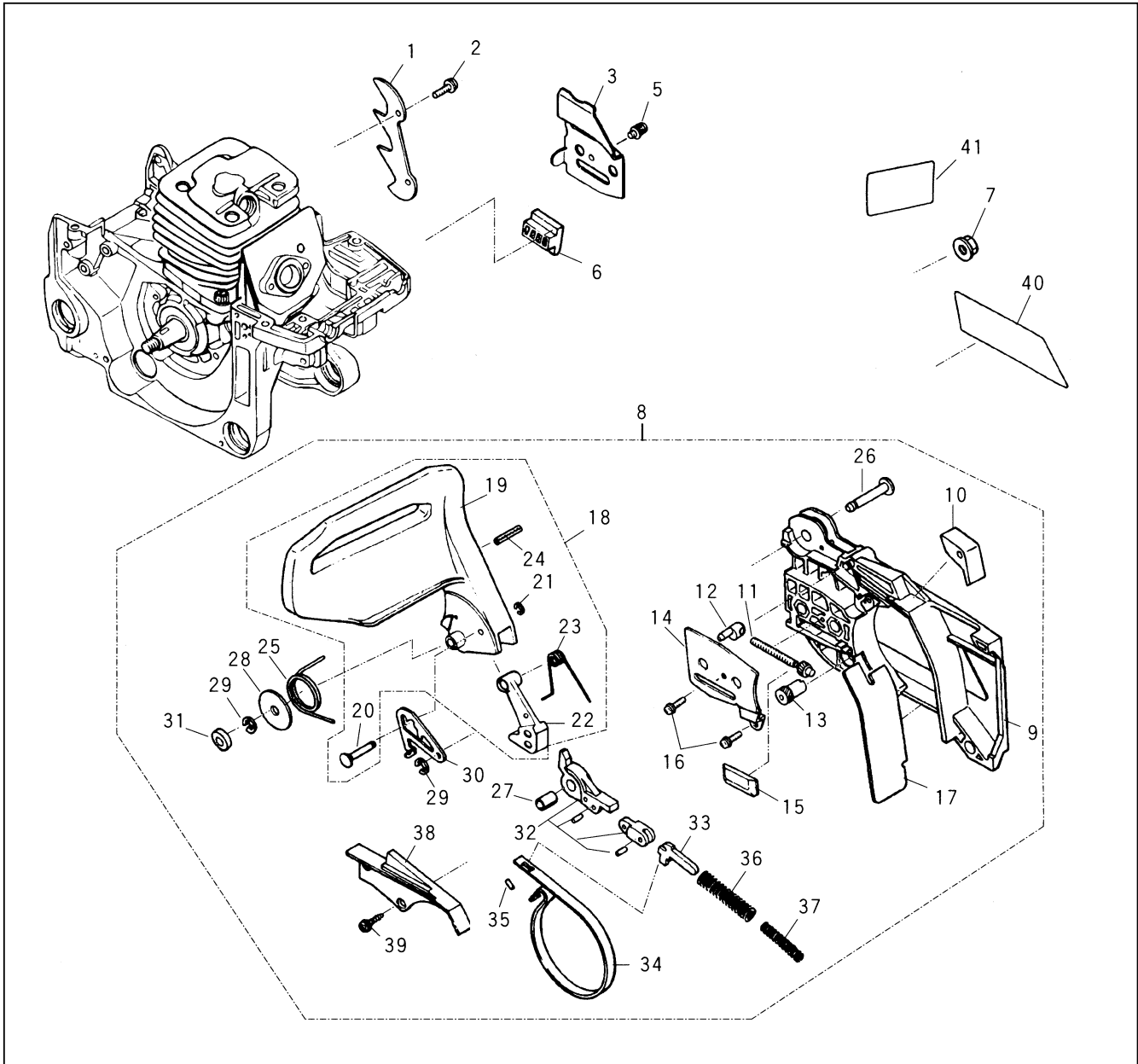

Key#	PART NUMBER	DESCRIPTION	Q'TY /UNIT	NOTE	Key#	PART NUMBER	DESCRIPTION	Q'TY /UNIT	NOTE
1	2670-25310	BUMPER	1		24	2880-54150	•• PIN	1	
2	2670-14320	SCREW	2		25	2670-54210	• SPRING	1	
3	2810-25421	PLATE	1		26	2670-54220	• PIN	1	
					27	2670-54231	• SPACER	1	
5	2670-25430	SCREW	1		28	3238-15230	• WASHER	1	
6	2670-25410	GUIDE	1		29	0308-00040	• RING	2	
7	3350-53410	NUT	2		30	2810-54240	• PLATE	1	
8	848C8E5404	CHAIN COVER ASSY	1		31	2810-54260	• SPACER	1	
9	2671-53114	• COVER	1		32	2670-54302	• BRAKE LEVER COMP.	1	
10	2880-53150	• STOPPER	1		33	2670-54411	• ARM	1	
11	2671-53210	• SCREW	1		34	2670-54510	• BAND	1	
12	2810-53221	• NUT	1		35	3356-24140	• ROLLER	1	
13	2671-53230	• GEAR	1		36	2670-54610	• SPRING	1	
14	2671-53240	• PLATE	1		37	2880-54650	• SPRING	1	
15	2670-25410	• GUIDE	1		38	2670-54621	• COVER	1	
16	2670-54630	• SCREW	2		39	2670-54630	• SCREW	3	
17	2671-53311	• PROTECTOR	1		40	2810-53122	LABEL	1	
18	848C8E5413	• GUARD COMP.	1		41	2874-54990	LABEL	1	
19	2880-54112	•• GUARD	1						
20	2670-54121	•• PIN	1						
21	0308-00030	•• RING	1						
22	2880-54130	•• WEIGHT	1						
23	848C8E54D1	•• SPRING	1						

Fig.7 BAR MOUNT, CHAIN BRAKE

G500AVS

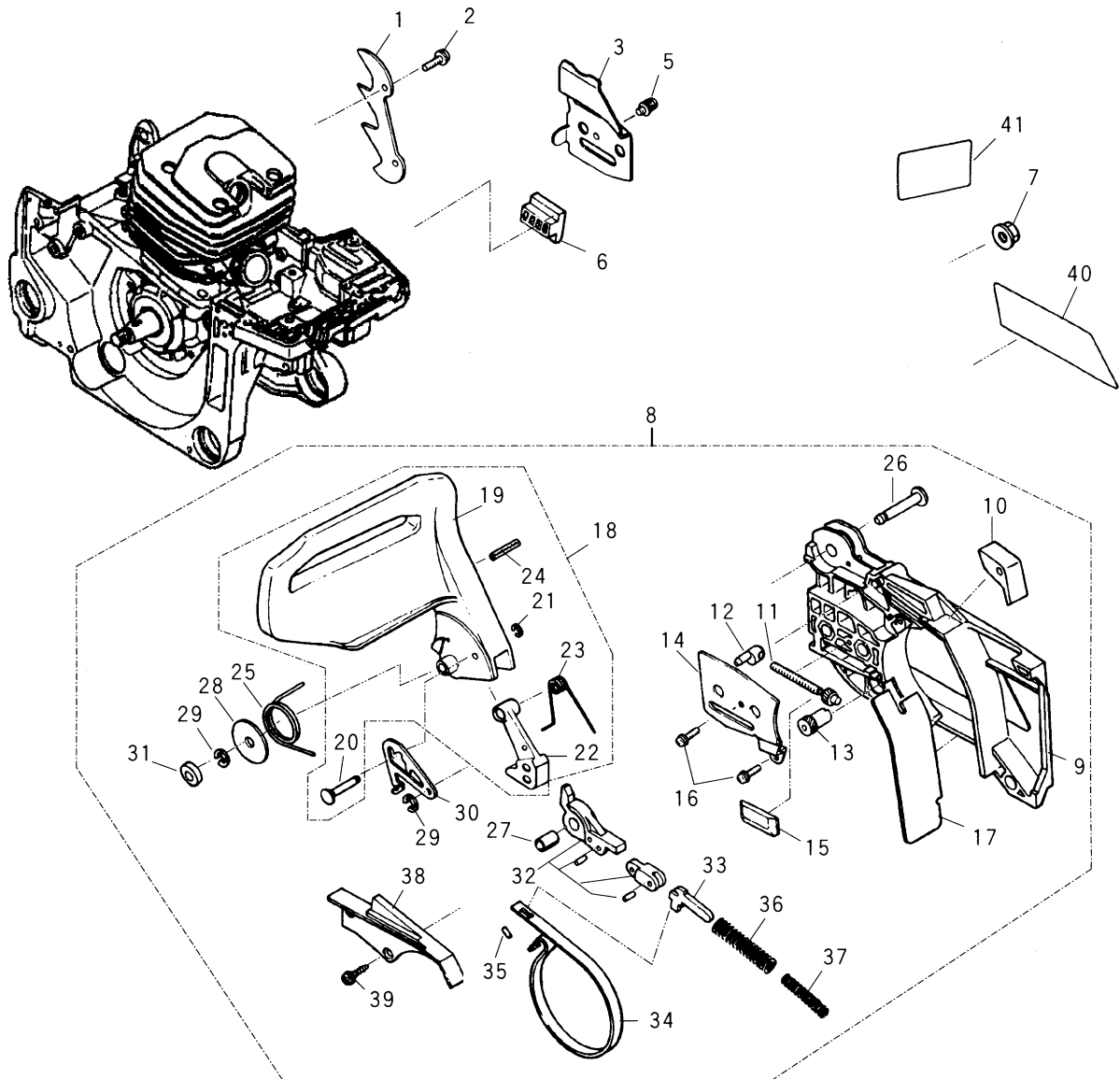

Key#	PART NUMBER	DESCRIPTION	Q'TY /UNIT	NOTE	Key#	PART NUMBER	DESCRIPTION	Q'TY /UNIT	NOTE
1	2670-25310	BUMPER	1		24	2880-54150	•• PIN	1	
2	2670-14320	SCREW	2		25	2670-54210	• SPRING	1	
3	2810-25421	PLATE	1		26	2670-54220	• PIN	1	
5	2670-25430	SCREW	1		27	2670-54231	• SPACER	1	
6	2670-25410	GUIDE	1		28	3238-15230	• WASHER	1	
7	3350-53410	NUT	2		29	0308-00040	• RING	2	
8	848C8E5404	CHAIN COVER ASSY	1		30	2810-54240	• PLATE	1	
9	2671-53114	• COVER	1		31	2810-54260	• SPACER	1	
10	2880-53150	• STOPPER	1		32	2670-54302	• BRAKE LEVER COMP.	1	
11	2671-53210	• SCREW	1		33	2670-54411	• ARM	1	
12	2810-53221	• NUT	1		34	2670-54510	• BAND	1	
13	2671-53230	• GEAR	1		35	3356-24140	• ROLLER	1	
14	2671-53240	• PLATE	1		36	2670-54610	• SPRING	1	
15	2670-25410	• GUIDE	1		37	2880-54650	• SPRING	1	
16	2670-54630	• SCREW	2		38	2670-54621	• COVER	1	
17	2671-53311	• PROTECTOR	1		39	2670-54630	• SCREW	3	
18	848C8E5413	• GUARD COMP.	1		40	2880-53122	LABEL	1	
19	2880-54112	•• GUARD	1		41	2874-54990	LABEL	1	
20	2670-54121	•• PIN	1						
21	0308-00030	•• RING	1						
22	2880-54130	•• WEIGHT	1						
23	848C8E54D1	•• SPRING	1						

Fig.8 GUIDE BAR, SAW CHAIN, TOOLS

G455AVS

G500AVS

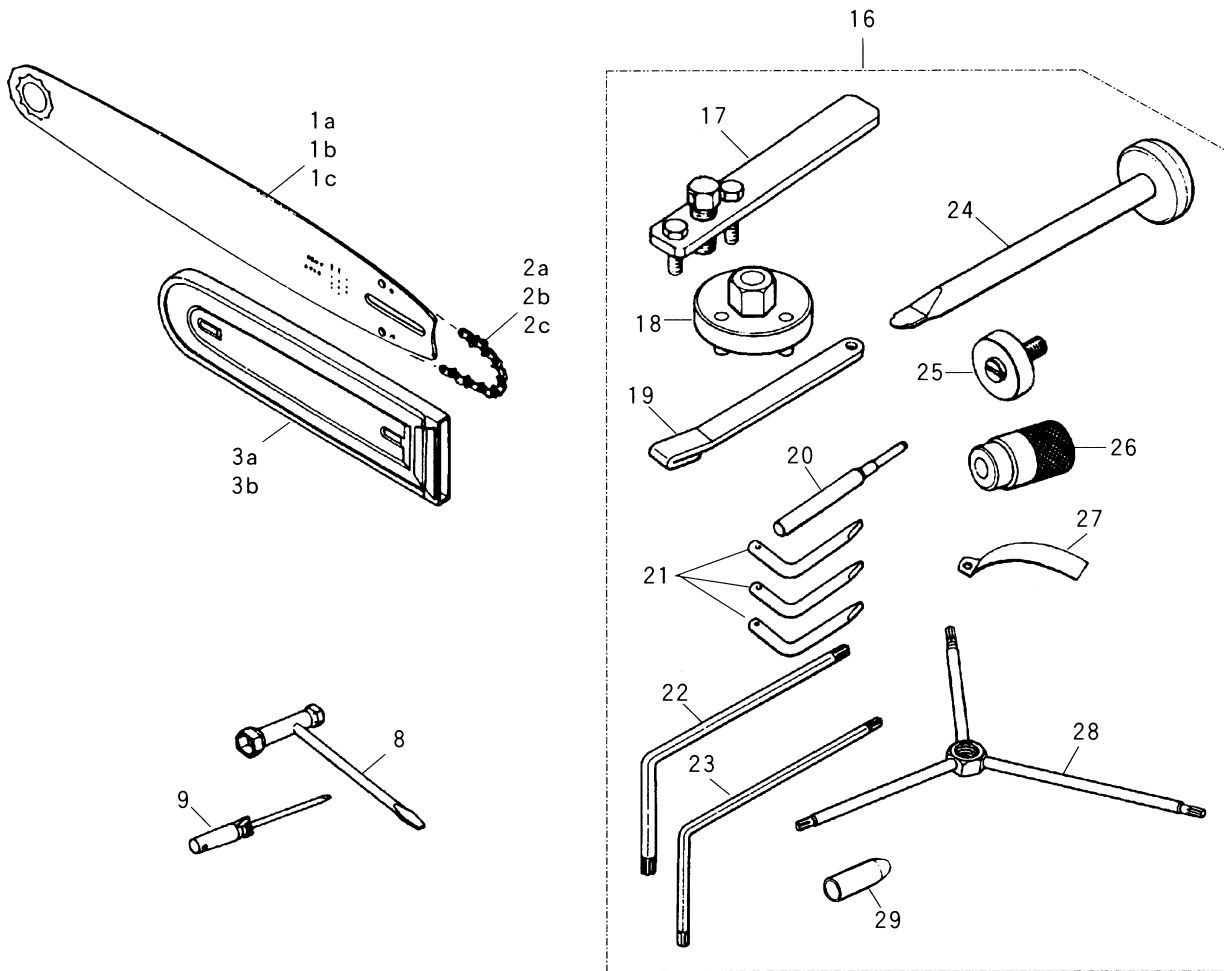

Key#	PART NUMBER	DESCRIPTION	Q'TY /UNIT	NOTE
1a	3644-52112	BAR 14	1	*1
1b	3645-52113	BAR 16	1	*1
1c	3646-52113-50	BAR 18	1	*1
2a	3611-52210-50	CHAIN 21BP-60E	1	*2
2b	3612-52210-50	CHAIN 21BP-66E	1	*3
2c	3646-52210-50	CHAIN 21BP-72E	1	*4
3a	3617-97110	PROTECTOR	1	*5
3b	3356-97110	PROTECTOR	1	*6
8	3320-91140	WRENCH	1	
9	2670-91150	SCREW DRIVER	1	
16	2670-96002	TOOL SET	1	*7
17	2890-96100	• PULLER ASSY	1	*7
18	2670-96210	• WRENCH	1	*7
19	2670-96220	• STOPPER	1	*7
20	3350-96230	• GUIDE	1	*7
21	2670-96240	• WRENCH	3	*7
22	2670-96310	• WRENCH	1	*7
23	2670-96320	• WRENCH	1	*7
24	2670-96510	• GUIDE	1	*7
25	3350-96620	• GUIDE	1	*7
26	2670-96660	• HOLDER	1	*7

Key#	PART NUMBER	DESCRIPTION	Q'TY /UNIT	NOTE
27	3350-96240	• GAUGE	1	*7
28	2670-96410	• WRENCH	1	*7
29	2810-96710	• GUIDE	1	*7

\*1 Raminated sprocket nose type, Gauge .058 (Opt. Part)  
 \*2 For Bar 14 (Opt. Part)  
 \*3 For Bar 16 (Opt. Part)  
 \*4 For Bar 18 (Opt. Part)  
 \*5 For Bar 14 (Opt. Part)  
 \*6 For Bar 16 & 18 (Opt. Part)  
 \*7 Special tools (Opt. Part)







# **KOMATSU ZENOAH CO.**

1-9 Minamidai, Kawagoe, Saitama, 350-1192 Japan

---

PRINTED IN JAPAN

PRINTED ON RECYCLED PAPER  
IMPRIMÉ SUR PAPIER RECYCLÉ  
GEDRUCKT AUF RECYCLING PAPIER  
STAMPATO SU CARTA RICICLATA  
IMPRESO EN PAPEL RECICLADO