

# PARTS LIST

## CHAIN SAW

# G415AVS

**NOTE :**

1. Use KOMATSU ZENOAH genuine parts specified in the parts list for repair and/or replacement.
2. KOMATSU ZENOAH does not warrant the machines, those which have been damaged by the use of any parts other than those specified by the company.
3. When placing orders of parts for repair and/or replacement, check if the model name and the serial number are suitable to those specified in the parts list, then use parts number described in the parts list.
4. The contents described in the parts list may change due to improvement.
5. The parts for the machine shall be supplied within ten (10) years after the machine is discontinued.  
[It is possible that some specific parts may be subject to change of their delivery term and list price within the limit of ten (10) years after the machine is discontinued. And it is also possible that some parts may be available even after the limit of ten (10) years.]

Fig.1 CLUTCH, IGNITION, POWER UNIT

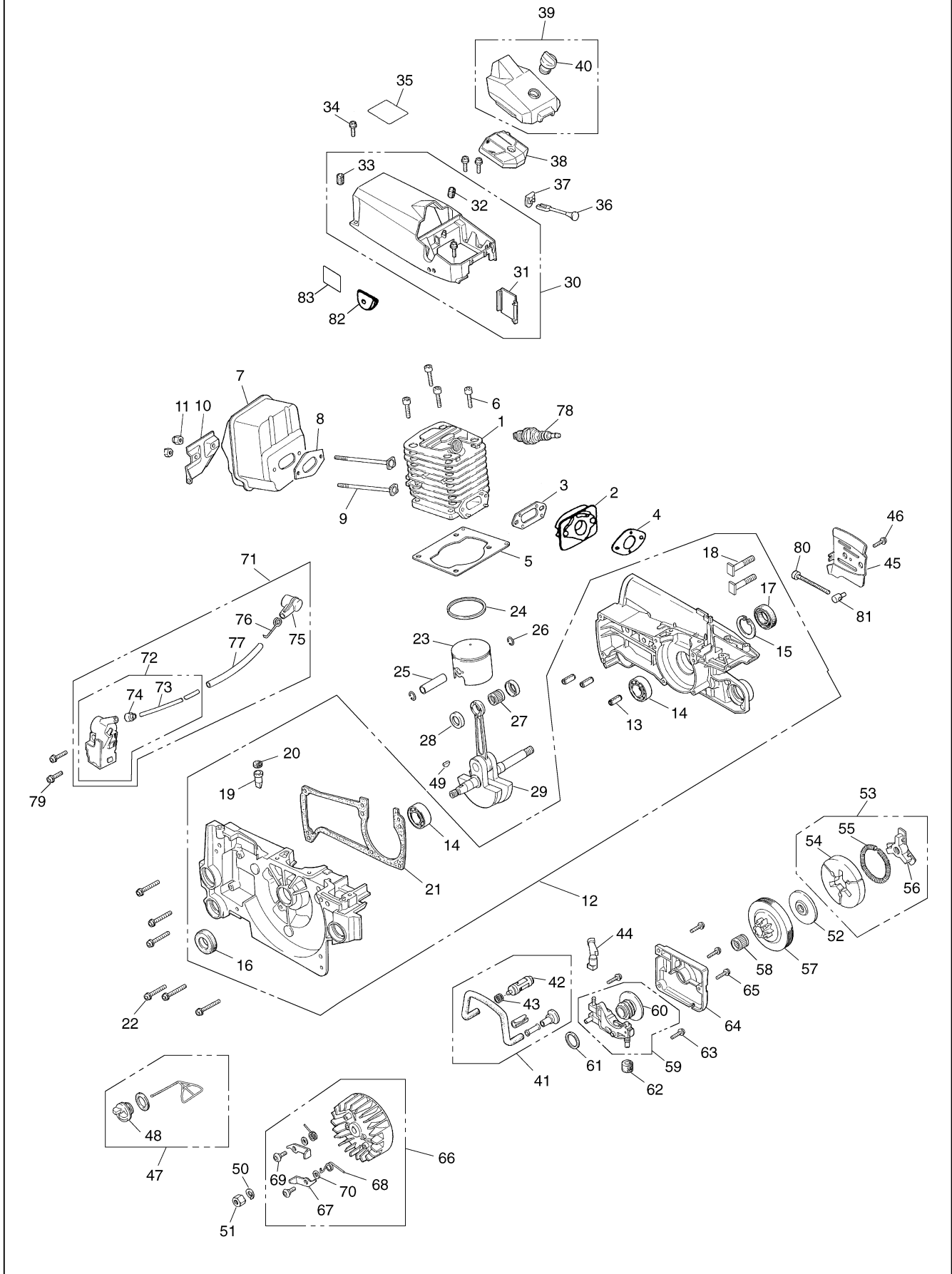
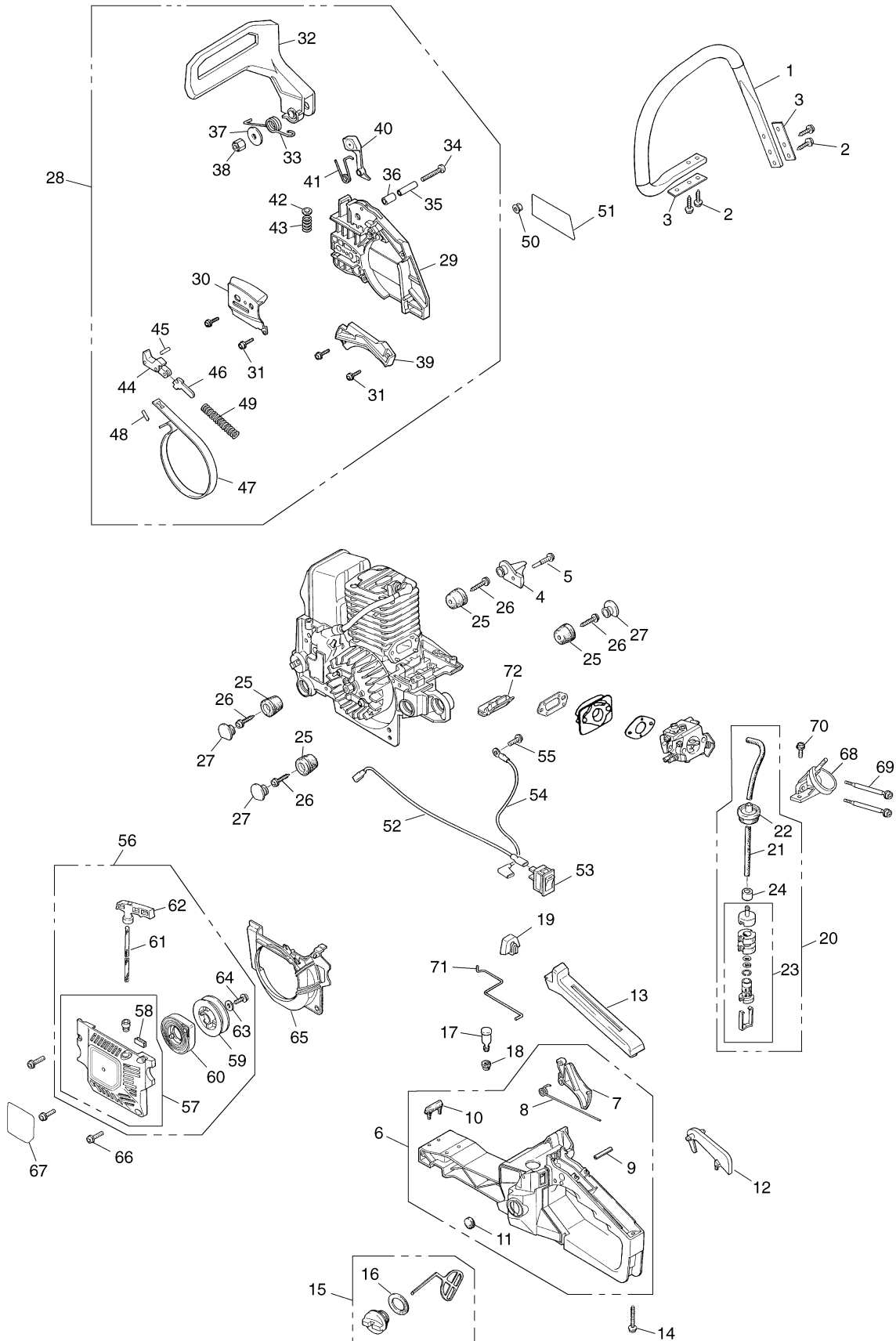

Fig.1 CLUTCH, IGNITION, POWER UNIT

Key#	PART NUMBER	DESCRIPTION	Q'TY /UNIT	NOTE	Key#	PART NUMBER	DESCRIPTION	Q'TY /UNIT	NOTE
1	2869-12110	Cylinder	1		57	2851-51111	Clutch drum(0.325"-7)	1	
2	2867-14110	Insulator	1		58	3310-51310	Needle bearing 10x13x13	1	
3	2850-14123	Gasket (K2867-06010)	1		59	848C706712	Oil pump	1	
4	3330-14121	Gasket (K2867-06010)	1		60	2851-55121	• Worm (7T)	1	
5	2850-14212	Gasket, Cylinder (K2867-06010)	1		61	2850-55211	Washer	1	
6	4820-13180	Bolt, Cylinder M5x20	4		62	2670-55220	Seal	1	
7	848C711511	Muffler	1		63	2670-55410	Screw M4x14	2	
8	T2100-15210	Gasket, Muffler	1		64	2850-55611	Pump cover	1	
9	3356-15220	Bolt, Muffler	2		65	2670-55410	Screw M4x14	3	
10	2867-15310	Stay	1		66	2867-71100	Rotor assy	1	
11	2850-15230	Nut, Muffler M5	2		67	2850-71120	• Pole	2	
12	2850-21007	Crankcase assy	1		68	3350-71131	• Spring	2	
13	3356-21130	• Spring Pin 5.2x10	3		69	2850-71140	• Screw M5x12	2	
14	2850-21240	• Bearing 12x32x10	2		70	2850-71151	• Washer 5x10x10	2	
15	04065-03212	• Snap Ring $\phi$ 32	1		71	2850-71302	Coil assy	1	
16	2169-21210	• Oil Seal 12x22x7	1		72	2850-71202	• Coil Complete	1	
17	2630-43150	• Oil Seal 12x32X5.5	1		73	2850-71220	•• Cord	1	
18	2850-21230	• Bolt	2		74	2670-71230	•• Grommet	1	
19	2850-21260	• Valve, Oil	1		75	2850-72110	• Plug cap	1	
20	2850-21250	• Valve Seal	1		76	1400-72121	• Spring	1	
21	848C6021D3	• Gasket, Case (K2867-06010)	1		77	2850-71320	• Tube 6x7x80	1	
22	4820-21310	Bolt M5x30	6		78	3699-90032-10	Spark plug (RCJ7Y)	1	
23	2869-41110	Piston $\phi$ 40.5	1		79	2670-14220	Screw M5x20	2	
24	2660-41211	Piston Ring $\phi$ 40.5	1		80	T2100-53210	Screw M5x50	1	
25	2850-41310	Piston Pin7x10x31.5	1		81	2867-53220	Nut	1	
26	1300-41320	Snap Ring	2		82	2867-82320	Grommet	1	
27	T2100-41410	Needle Bearing 10x14x10.7	1		83	T2990-21100	LABEL (110dB)	1	
28	2850-41510	Washer	2						
29	848C604203	Crankshaft comp.	1						
30	2850-31103	Cylinder cover comp.	1						
31	2856-31120	• Cap, Cylinder cover	1						
32	2810-83410	• Grommet, Air cleaner	1						
33	3356-31152	• Grommet, Cylinder	1						
34	2670-14320	Screw M5x14	4						
35	2869-31510	Label	1						
36	2850-82411	Choke rod	1						
37	2850-82421	Grommet, Choke	1						
38	2850-83100	Air cleaner comp.	1						
39	2850-83303	Cleaner cover comp.	1						
40	2841-83320	• Knob	1						
41	2850-23101	Oil pipe comp.	1						
42	2670-23131	• Oil filter	1						
43	3310-82230	• Clip	1						
44	2850-23211	Oil pipe, out let	1						
45	T2002-25410	Guide Plate(A)	1						
46	2670-25430	Screw M4x10	1						
47	2841-31801	Oil cap assy	1						
48	2841-31820	• Gasket, cap	1						
49	1000-43240	Key	1						
50	0290-20820	Washer	1						
51	3350-43231	Nut M8	1						
52	2850-51211	Plate	1						
53	848C605122	Clutch assy	1						
54	3317-51220	• Clutch shoe	3						
55	3317-51231	• Spring	1						
56	848C6051F1	• Boss(B)	1						

Fig.2 BREAKING, STARTING, FUELING SYSTEMS



**Fig.2 BREAKING, STARTING, FUELING SYSTEMS**

Key#	PART NUMBER	DESCRIPTION	Q'TY /UNIT	NOTE	Key#	PART NUMBER	DESCRIPTION	Q'TY /UNIT	NOTE
1	2851-32111	Left handle	1		57	2850-75102	• Recoil case comp.	1	
2	8488252711	Screw M5x27	4		58	2850-75150	•• Cushion	1	
3	2851-32180	Plate	2		59	2850-75211	• Reel	1	
4	2850-25211	Chain catcher	1		60	2850-75301	• Spring comp.	1	
5	2850-25220	Screw, Stopper M5x33	1		61	3317-75410	• Rope	1	
6	2850-33007	Right handle assy	1		62	3330-75421	• Knob	1	
7	2850-33313	• Throttle lever	1		63	1400-86280	• Washer	1	
8	3356-33321	• Throttle spring	1		64	8488251901	• Screw TP5x19	1	
9	04025-00524	• Spring pin 5.2x24	1		65	2850-75611	Fan cover	1	
10	2670-33280	• Damper(A)	1		66	2670-14320	Screw M5x14	3	
11	2850-33370	• Helper, Magnetto	1		67	2869-75131	Label, recoil	1	
12	848C3033E3	Arm	1		68	2850-82114	Manifold	1	
13	2850-34111	Grip cover	1		69	2867-82210	Bolt M4x70	2	
14	8488252711	• Screw M5x27	1		70	2670-14320	Screw M5x14	1	
15	2670-34401	Tank cap assy	1		71	2850-82511	Throttle rod	1	
16	2670-34430	• Gasket, Tankcap	1		72	T2100-82520	Grommet, throttle	1	
17	2850-34501	Breather assy	1						
18	3317-85120	Grommet	1						
19	2850-34150	Helper, rear	1						
20	2851-34302	Fuel pipe assy	1						
21	2850-34311	• Fuel pipe	1						
22	2851-34321	• Grommet	1						
23	3302-85400	• Filter assy	1						
24	2850-34350	• Collar	1						
25	2616-35141	Damper	4						
26	8488251601	Screw M5x16	4						
27	2856-35180	Damper cap	3						
28	2869-54002	Chain brake assy	1						
29	2850-53117	• Chain cover	1						
30	2850-53250	• Guide plate (B)	1						
31	2670-54630	• Screw M4x12	4						
32	2850-54111	• Front guard	1						
33	2850-54120	• Return spring	1						
34	2850-54130	• Screw M5x40	1						
35	2850-54140	• Spacer inner	1						
36	2850-54211	• Spacer outer	1						
37	3330-75411	• Washer	1						
38	3310-53331	• Nut(B) M5 Nylon nut	1						
39	2850-54626	• Spring cover	1						
40	848C605423	• Weight	1						
41	2872-54230	• Spring	1						
42	2851-54260	• Stopper plate	1						
43	2851-54270	• Spring	1						
44	2851-54301	• Brake lever comp.	1						
45	2851-54350	• Roller	1						
46	2670-54411	• Slide arm	1						
47	2851-54510	• Brake band	1						
48	3356-24140	• Roller	1						
49	2670-54610	• Brake spring	1						
50	3350-53410	Nut M8	2						
51	2869-53150	Label, Chain cover	1						
52	2850-71513	Switch cord	1						
53	2850-74102	Switch assy	1						
54	2850-74213	Cord	1						
55	2670-14130	Screw M5x10	1						
56	2867-75000	Starter assy	1						

Fig.3 CARBURETOR

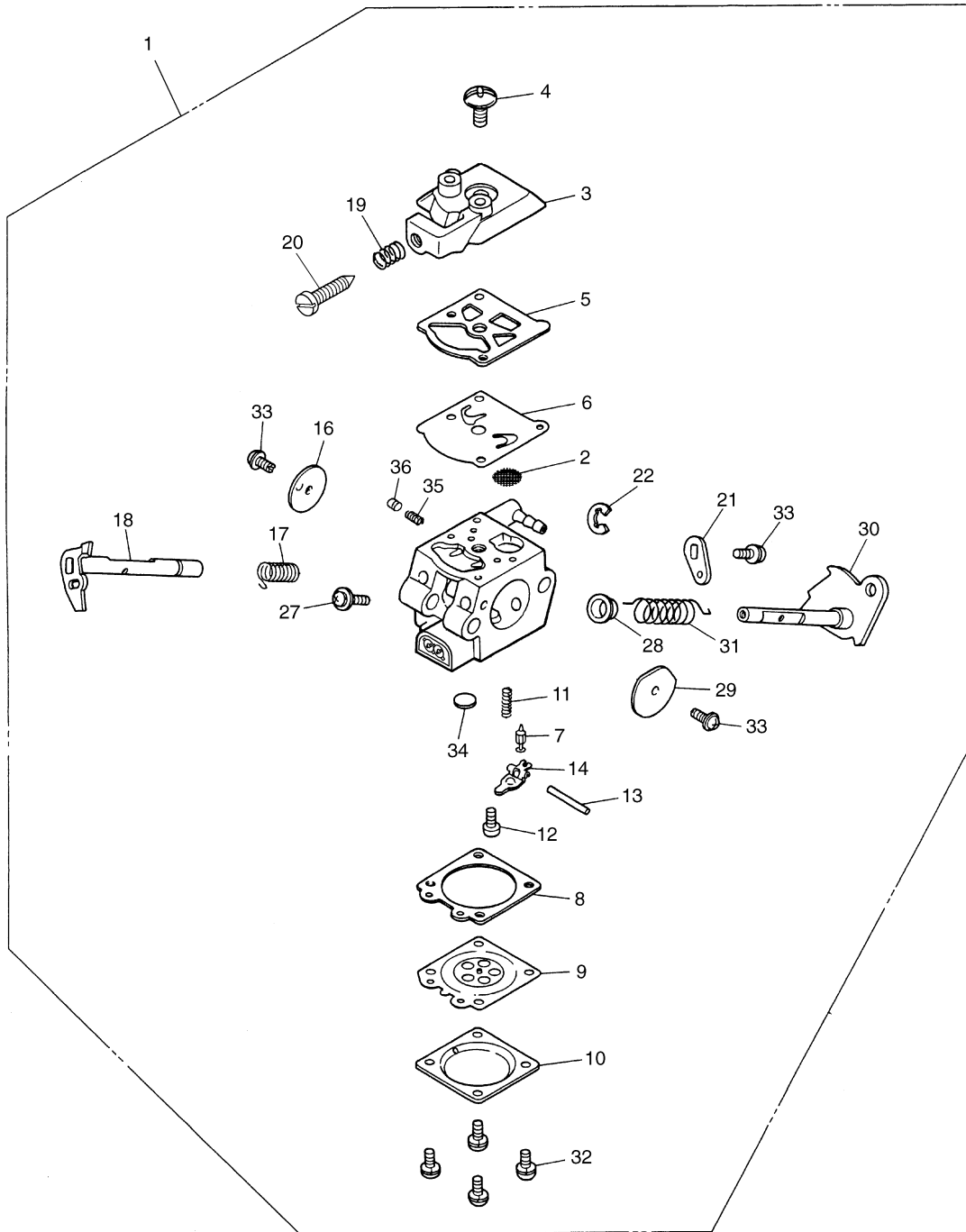
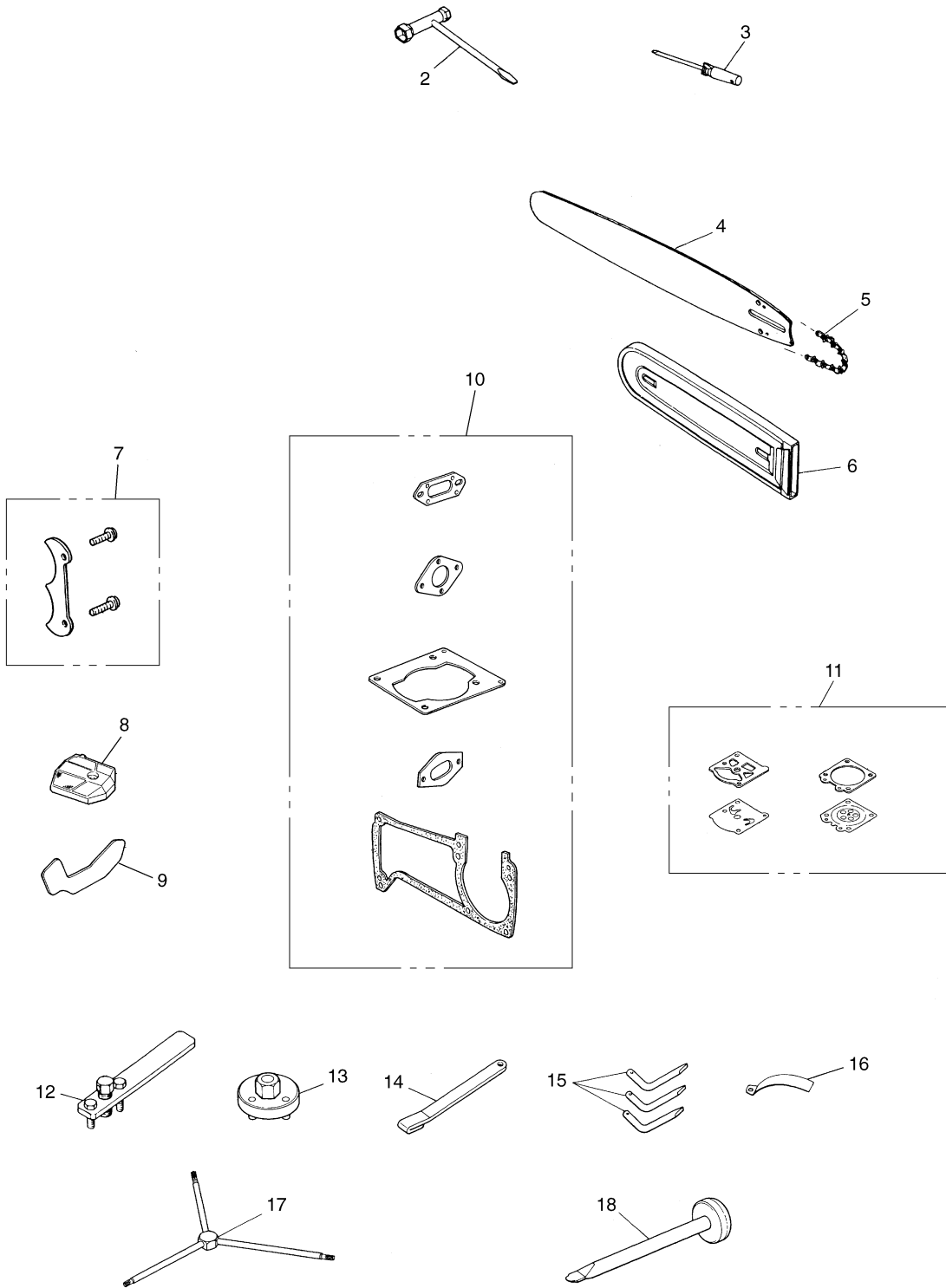

Fig.3 CARBURETOR

Key#	PART NUMBER	DESCRIPTION	Q'TY /UNIT	NOTE	Key#	PART NUMBER	DESCRIPTION	Q'TY /UNIT	NOTE
1	848C718100	Carburetor assy	1	WT753					
2	3306-81380	• Screen	1						
3	2850-81120	• Pump cover	1						
4	3310-81130	• Screw	1						
5	3304-81140	• Gasket, pump	1						
6	1172-81150	• Diaphragm, pump	1						
7	3356-81310	• Valve	1						
8	2850-81290	• Gasket	1						
9	3310-81260	• Diaphragm	1						
10	3310-81280	• Cover	1						
11	2867-81270	• Spring	1						
12	3310-81240	• Screw M lever pin	1						
13	3310-81250	• Pin, lever	1						
14	3310-81230	• Lever	1						
16	3356-81340	• Throttle valve	1						
17	2670-81410	• Throttle spring	1						
18	848C7181T0	• Throttle shaft	1						
19	3350-81380	• Idle spring	1						
20	2630-81330	• Idle screw	1						
21	2670-81440	• Throttle lever	1						
22	1148-81390	• Ring	1						
27	2850-81190	• Screw	1						
28	2850-81430	• Bush	1						
29	2670-81450	• Choke valve	1						
30	2850-81461	• Choke shaft	1						
31	T2002-81350	• Choke spring	1						
32	3310-81351	• Screw	4						
33	2880-81470	• Screw, valve	3						
34	1480-81420	• Plug	1						
35	2810-81530	Spring	1						
36	848C7180N0	Piston	1						

Fig.4 GUIDE BAR, SAW CHAIN, TOOLS





**Fig.4 GUIDE BAR, SAW CHAIN, TOOLS**

Key#	PART NUMBER	DESCRIPTION	Q'TY /UNIT	NOTE	Key#	PART NUMBER	DESCRIPTION	Q'TY /UNIT	NOTE
2	3320-91140	Plug 13x19	1						
3	2670-91150	Driver	1						
4	2939-52110-50	Sprocket nose bar 16"	1						
5	3699-91241	Chain 16"(95VP-66E)	1						
6	3356-97110	Protector	1						
7	2850-98100	Spike kit	1						
8	2850-98300	Air cleaner comp.	1	OP					
9	2850-98210	Snow protector	1	OP					
10	2867-06010	Gasket kit	1	OP					
11	T2100-06020	Gasket kit	1	OP					
12	2890-96100	Puller assy (for rotor)	1	OP					
13	2670-96210	Wrench (for clutch)	1	OP					
14	2670-96220	Stopper (for piston)	1	OP					
15	2670-96240	Wrench (for clutch assy)	3	OP					
16	3350-96240	Gauge	1	OP					
17	2850-96410	Wrench	1	OP					
18	2670-96510	Guide (for brake spring)	1	OP					



# **KOMATSU ZENOAH CO.**

1-9 Minamidai, Kawagoe, Saitama, 350-1192 Japan

---

PRINTED IN JAPAN

PRINTED ON RECYCLED PAPER  
IMPRIMÉ SUR PAPIER RECYCLÉ  
GEDRUCKT AUF RECYCLING PAPIER  
STAMPATO SU CARTA RICICLATA  
IMPRESO EN PAPEL RECICLADO