

PARTS LIST

BRUSHCUTTERS

BCZ3000DL
BCZ3000DW

NOTE :

1. Use KOMATSU ZENOAH genuine parts as specified in the parts list for repair and/or replacement.
2. KOMATSU ZENOAH does not warrant the machines, which have been damaged by the use of any parts other than those specified by the company.
3. When placing parts orders for repair and/or replacement, check if the model name and the serial number are applicable to those specified in the parts list, then use parts number described in the parts list.
4. The contents described in the parts list are accurate as of the date and may change due to improvement.
5. The parts for the machine shall be supplied ten (10) years after the machine is discontinued. [It is possible that some specific parts may be subject to change of their delivery term and list price within the limit of ten (10) years after the machine is discontinued. It is also possible that some parts may be available even after the limit of ten (10) years.]

APPLICABLE SERIAL NUMBERS:

300101 and up

January 2004

Fig.1 CUTTER GROUP

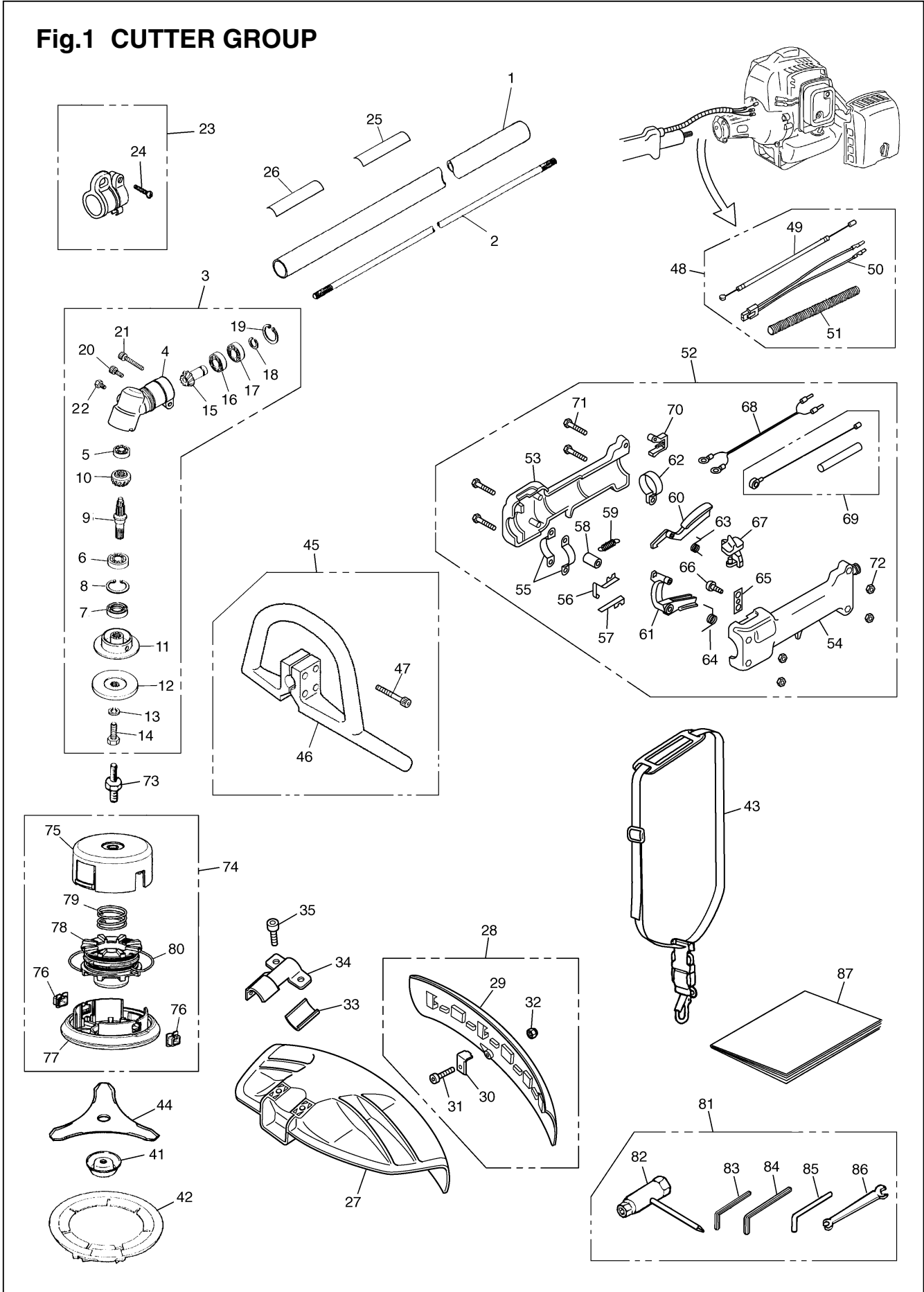

Fig.1 CUTTER GROUP

Key#	PART NUMBER	DESCRIPTION	Q'TY /UNIT	NOTE	Key#	PART NUMBER	DESCRIPTION	Q'TY /UNIT	NOTE
1	T3147-11300	PIPE COMP. 1500x24xT1.5	1		57	K3300-000020	• PLATE (B)	1	
2	3520-12213	SHAFT, spline ϕ 7x7teeth	1	1536x7	58	K5100-000240	• COLLAR	1	
3	848JA06100	GEARCASE ASSY	1		59	K5100-000220	• SPRING	1	
4	6440-13122	• GEARCASE	1		60	K2300-000260	• SAFETY LEVER	1	
5	06000-00626	• BEARING	1		61	K2300-000250	• THROTTLE LEVER	1	
6	06000-06000	• BEARING	1		62	K3200-000380	• CLAMP (B)	1	
7	3565-13130	• SEAL	1		63	K5100-000230	• SPRING	1	
8	04065-02612	• RING	1		64	K5100-000210	• SPRING	1	
9	6440-13211	• SHAFT	1		65	K2300-000270	• PLATE	1	
10	6440-13220	• GEAR	1		66	B1122-C2910H	• SCREW	1	
11	6440-13242	• HOLDER (A)	1		67	K2300-000280	• SWITCH	1	
12	6019-13250	• HOLDER (B)	1		68	K5200-000090	• CORD	1	
13	3560-13290	• WASHER	1		69	K5100-000270	• CABLE COMP.	1	
14	3560-13261	• BOLT	1	M7x25(L)		_____	•• THROTTLE CABLE	1	
15	T3002-13310	• PINION	1			_____	•• SLEEVE	1	
16	06000-00609	• BEARING	1		70	K2300-000390	• LID	1	
17	06001-00609	• BEARING	1		71	B1176-090530	• SCREW	4	
18	T3300-13330	• RING	1		72	B1181-04054506	• NUT	4	
19	04065-02412	• RING	1		73	6041-99240	SHAFT	1	
20	01252-30512	• BOLT	1		74	T3189-15102	TAP HEAD COMP.	1	
21	3350-21320	• BOLT	1	M5x30	75	T3189-15112	• CASE	1	
22	0224-40610	• BOLT	1		76	T3189-15191	• EYELET	2	
23	T3300-17202	HANGER COMP.	1		77	T3189-15132	• COVER	1	
24	0263-90520	• SCREW	1		78	T3189-15142	• CORD HOLDER	1	
25	848JC290R0	PLATE NAME	1		79	T3189-15160	• SPRING	1	
26	6425-12552	PLATE CAUTION	1		80	T3189-15180	• CORD	1	
27	848JL066A3	GUARD	1		81	T3087-91000	TOOL-SET	1	
28	848JL066B3	GUARD ASSY	1		82	T3039-91310	• SOCKET	1	
29	848JL066E3	• GUARD-N	1		83	09007-00425	• WRENCH	1	
30	848JL066B2	• BLADE	1		84	09007-00528	• WRENCH	1	
31	4820-72150	• BOLT TORX	1	M4x16	85	3540-91110	• BAR	1	
32	3238-13150	• NUT	1	M4	86	3540-91120	• SPANNER	1	
33	3550-14170	SPACER	1		87	848JC293A0	MANUAL	1	
34	848JC066C1	BRACKET	1						
35	01252-30630	BOLT	2						
41	3560-13284	COVER (BOLT)	1						
42	6251-15910	COVER (BLADE)	1						
43	T3300-17100	STRAP ASSY	1						
44	6298-E3390	BLADE	1						
45	T3110-14000	HANDLE ASSY	1						
46	T3110-14110	• HANDLE	1						
47	0263-90530	• SCREW	4						
48	T1504-83000	CABLE ASSY	1						
49	T1504-83100	• CABLE COMP.	1						
50	T3037-14520	• CORD COMP.	1						
51	6420-14511	• TUBE	1						
52	T3110-18000	GRIP ASSY	1						
53	K2300-000240	• GRIP (R)	1						
54	K2300-000230	• GRIP (L)	1						
55	K3200-000370	• CLAMP (A)	2						
56	K3300-000010	• PLATE (A)	1						

Fig.2 CUTTER GROUP

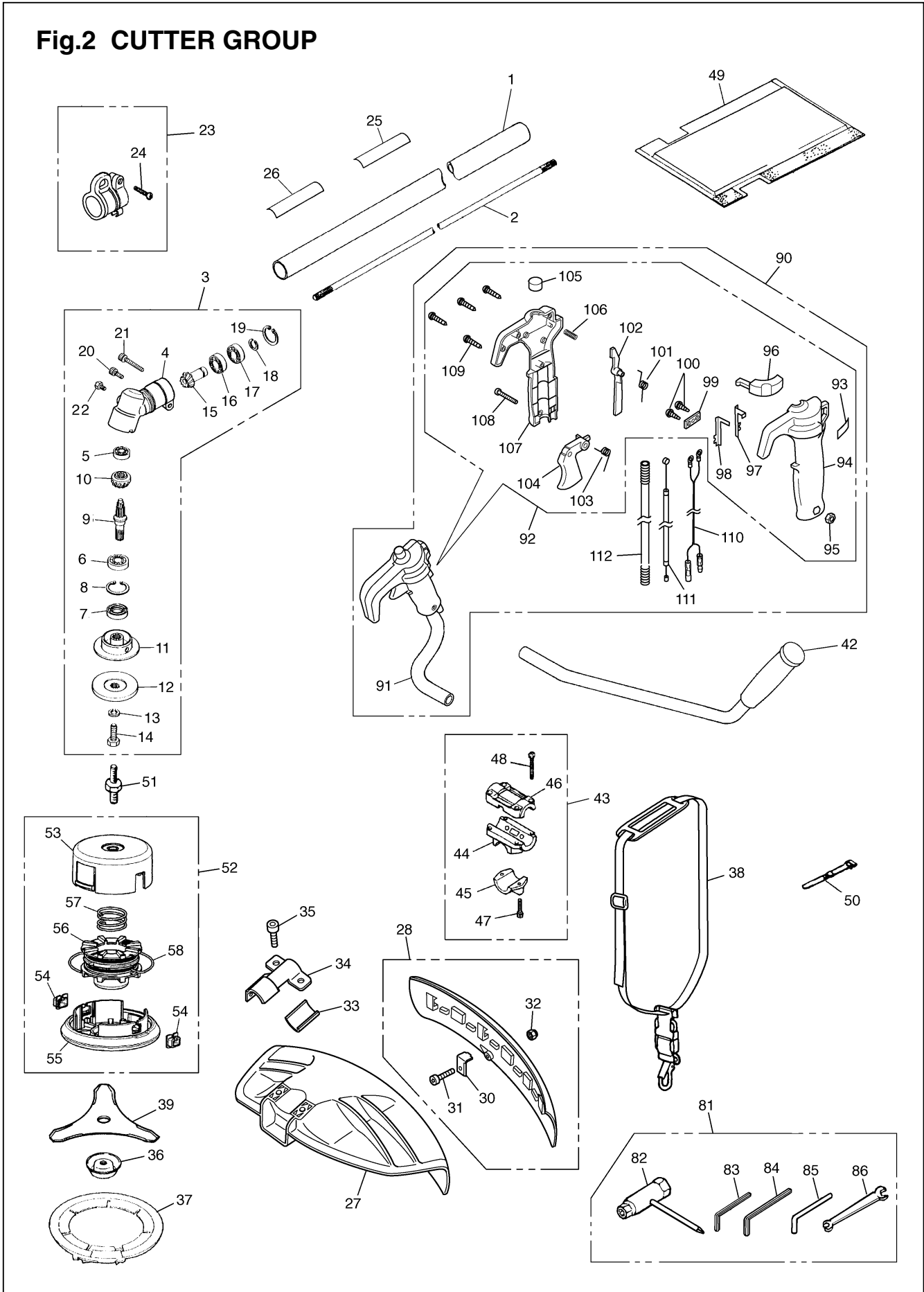

Fig.2 CUTTER GROUP

Key#	PART NUMBER	DESCRIPTION	Q'TY /UNIT	NOTE	Key#	PART NUMBER	DESCRIPTION	Q'TY /UNIT	NOTE
1	T3147-11300	PIPE COMP. 1500x24xT1.5	1		54	T3189-15191	• EYELET	2	
2	3520-12213	SHAFT, spline ϕ 7x7teeth	1	1536x7	55	T3189-15132	• COVER	1	
3	848JA06100	GEARCASE ASSY	1		56	T3189-15142	• CORD HOLDER	1	
4	6440-13122	• GEARCASE	1		57	T3189-15160	• SPRING	1	
5	06000-00626	• BEARING	1		58	T3189-15180	• CORD	1	
6	06000-06000	• BEARING	1		81	T3087-91000	TOOL-SET	1	
7	3565-13130	• SEAL	1		82	T3039-91310	• SOCKET	1	
8	04065-02612	• RING	1		83	09007-00425	• WRENCH	1	
9	6440-13211	• SHAFT	1		84	09007-00528	• WRENCH	1	
10	6440-13220	• GEAR	1		85	3540-91110	• BAR	1	
11	6440-13242	• HOLDER (A)	1		86	3540-91120	• SPANNER	1	
12	6019-13250	• HOLDER (B)	1		90	T3111-14100	HANDLE-R ASSY	1	
13	3560-13290	• WASHER	1		91	T3111-14110	• HANDLE-R	1	
14	3560-13261	• BOLT	1	M7x25(L)	92	K6010-000550	• GRIP&LEV COMP	1	
15	T3002-13310	• PINION	1		93	K2200-000040	• LABEL	1	
16	06000-00609	• BEARING	1		94	K2300-000050	• GRIP (L)	1	
17	06001-00609	• BEARING	1		95	B1181-040545	• NUT	1	
18	T3300-13330	• RING	1		96	K2300-000080	• SWITCH	1	
19	04065-02412	• RING	1		97	K5100-000030	• SPRING	1	
20	01252-30512	• BOLT	1		98	K5100-000040	• SPRING	1	
21	3350-21320	• BOLT	1	M5x30	99	K2300-000090	• HOLDER	1	
22	0224-40610	• BOLT	1		100	B1122-C2910H	• SCREW, tapping	2	M3x10
23	T3300-17202	HANGER COMP.	1		101	K5100-000020	• SPRING	1	
24	0263-90520	• SCREW	1		102	K2300-000070	• LEVER	1	
25	848JC290R0	PLATE NAME	1		103	K5100-000010	• SPRING	1	
26	6425-12552	PLATE CAUTION	1		104	K2300-000060	• LEVER	1	
27	848JL066A3	GUARD	1		105	K1300-000060	• PLUG	1	
28	848JL066B3	GUARD ASSY	1		106	K5100-000050	• SPRING	1	
30	848JL066B2	• BLADE	1		107	K2300-000040	• GRIP (R)	1	
31	4820-72150	• BOLT TORX	1	M4x16	108	B1111-A0530H	• SCREW	1	M5x30
32	3238-13150	• NUT	1	M4	109	B1122-C4220H	• SCREW, tapping	5	M4x20
33	3550-14170	SPACER	1		110	K5200-000060	• CORD	1	
34	848JC066C1	BRACKET	1		111	K5100-000130	• CABLE	1	
35	01252-30630	BOLT	2		112	K5200-000080	• TUBE	1	
36	3560-13284	COVER (BOLT)	1						
37	6251-15910	COVER (BLADE)	1						
38	T3300-17100	STRAP ASSY	1						
39	6298-E3390	BLADE	1						
42	T3111-14300	HANDLE-L COMP.	1						
43	3583-14101	BRACKET ASSY	1						
44	3583-14111	• BRACKET	1						
45	3583-14121	• CAP-L	1						
46	3257-14192	• CAP-U	1						
47	01252-30522	• BOLT	2						
48	01252-30525	• BOLT	4						
49	4050-17110	PROTECTOR	1						
50	3540-93120	BAND	1						
51	6041-99240	SHAFT	1						
52	T3189-15102	TAP HEAD COMP.	1						
53	T3189-15112	• CASE	1						

Fig.3 ENGINE GROUP

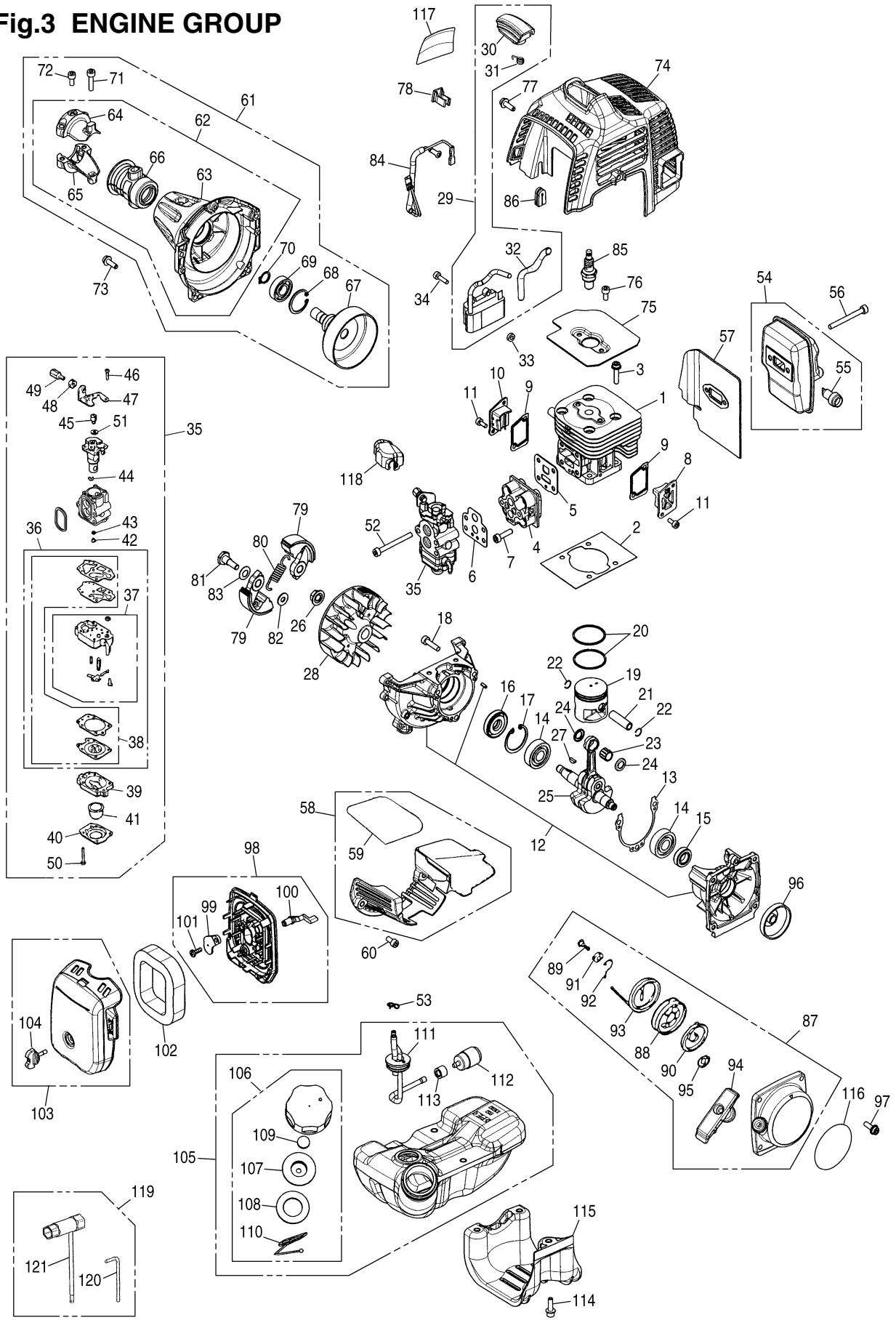

Fig.3 ENGINE GROUP

Key#	PART NUMBER	DESCRIPTION	Q'TY /UNIT	NOTE	Key#	PART NUMBER	DESCRIPTION	Q'TY /UNIT	NOTE
1	848F6012A1	CYLINDER	1		64	T1700-31212	•• BRACKET (A)	1	
2	T1590-12210	GASKET, base	1		65	T1700-31221	•• BRACKET (B)	1	
3	4820-12130	BOLT TORX	4	M5x22	66	T1700-31232	•• CUSHION	1	
4	848F6014A1	INSULATOR	1		67	T1590-31120	• DRUM	1	
5	T1590-13120	GASKET, insu	1		68	04065-02812	• SNAP RING	1	
6	T1590-13130	GASKET, carb	1		69	T1701-31150	• BEARING	1	
7	T4950-52021	BOLT TORX	4	M5x20	70	04064-01210	• SNAP RING	1	
8	848F6012C1	COVER, trs	1		71	4820-13180	• BOLT TORX	2	M5x20
9	848F6012E1	GASKET, tr	2		72	4820-12350	• BOLT TORX	1	M5x10
10	848F6012D2	COVER, trf	1		73	4820-85510	BOLT TORX	4	M5x16
11	4820-16310	BOLT TORX	4	M4x10	74	848F6031A1	COVER, engine	1	
12	848F602111	CRANKCASE COMP.	1		75	848F6012G1	PLATE, cyl	1	
13	848F6021D1	GASKET, case	1		76	4820-12350	BOLT TORX	2	M5x10
14	84889C3200	BEARING	2		77	4820-32120	BOLT TORX	2	M5x16
15	4810-21210	SEAL	1		78	T1600-72210	CLAMP	1	
16	1650-21220	SEAL	1		79	T1590-51110	SHOE	2	
17	04065-03212	SNAP RING	2		80	8488E93700	SPRING	1	
18	4820-13180	BOLT TORX	3	M5x20	81	1140-51250	SCREW	2	
19	848F6041A1	PISTON	1		82	1140-51230	WASHER	2	
20	T1590-41210	RING	2		83	8488728000	WASHER, wave	2	
21	T2200-41310	PIN	1		84	T1551-73200	CORD COMP.	1	
22	3310-41320	SNAP RING	2		85	T2070-73110	SPARK PLUG	1	
23	3310-41410	BEARING	1		86	4810-72120	GROMMET	1	
24	1650-41510	WASHER	2		87	T1551-75100	RECOIL ASSY	1	
25	848F604201	CRANKSHAFT COMP.	1		88	4500-75120	• REEL	1	
26	1650-43230	NUT	1		89	4500-75150	• SCREW	1	
27	1000-43240	KEY	1		90	1850-75130	• SPRING	1	
28	T1700-71110	ROTOR	1		91	4500-75180	• COLLAR	1	
29	T1590-71200	COIL ASSY	1		92	4500-75190	• ARM	1	
30	4810-72111	• CAP	1		93	4810-75160	• ROPE	1	
31	T1108-72120	• SPRING	1		94	3330-75421	• KNOB	1	
32	2850-71320	• TUBE	1		95	4810-75170	• PLATE	1	
33	1260-71261	SPACER	2		96	4500-75210	PULLEY	1	
34	4820-72150	BOLT TORX	2	M4x16	97	4820-32120	BOLT TORX	4	M5x16
35	848F608101	CARBURETOR ASSY	1		98	T1551-82100	BODY ASSY	1	
36	848F600630	• REBUILD KIT	1		99	T1512-82130	• PLATE, choke	1	
37	1850-81450	•• BODY ASSY	1		100	T1600-82140	• LEVER	1	
38	4810-06021	•• GASKET KIT	1		101	T1108-82190	• SCREW	1	
39	1850-81490	• BODY, purge	1		102	T1551-82170	ELEMENT	1	
40	1850-81520	• COVER, pump	1		103	T1551-82200	COVER ASSY	1	
41	1751-81510	• PUMP, priming	1		104	T1108-82220	• KNOB	1	
42	4810-81251	• JET	1		105	848F608501	TANK ASSY	1	
43	1751-81240	• O-RING	1		106	T1015-85202	• CAP ASSY	1	
44	1751-81130	• RING	1		107	4500-85300	•• HOLDER ASSY	1	
45	1881-81140	• SWIVEL	1		108	4500-85220	•• PACKING	1	
46	1752-81110	• SCREW	2		109	5601-85260	•• FILTER	1	
47	5500-81120	• BRACKET	1		110	4820-85260	•• STOPPER	1	
48	1751-81180	• NUT, adjuster	1		111	848F608530	• PIPE COMP.	1	
49	1918-81170	• SCREW, adjuster	1		112	3302-85400	• FILTER ASSY	1	
50	1850-81530	• SCREW	4		113	2841-31280	• COLLAR	1	
51	5500-81160	• WASHER	1		114	T4950-52030	BOLT TORX	3	M5x20
52	4820-15310	BOLT TORX	2	M5x50	115	848F6085Z0	GUARD, tank	1	
53	1950-86120	CLIP	1		116	848F6190C0	LABEL, recoil	1	
54	4810-15100	MUFFLER ASSY	1		117	T1504-31130	LABEL	1	
55	4810-15140	• ARRESTER	1		118	4500-81910	COVER	1	
56	4820-15310	BOLT TORX	2	M5x50					
57	848F6015C0	GASKET, muff	1						
58	848F601530	PLATE ASSY	1						
59	848F6015F0	• SHEET	1						
60	4820-12350	BOLT TORX	2	M5x10					
61	848F615300	HOUSING ASSY	1						
62	T1590-31100	• HOUSING COMP.	1						
63	T1590-31110	•• HOUSING	1						



KOMATSU ZENOAH CO.

1-9 Minamidai, Kawagoe, Saitama, 350-1192 Japan

PRINTED IN JAPAN

PRINTED ON RECYCLED PAPER
IMPRIMÉ SUR PAPIER RECYCLÉ
GEDRUCKT AUF RECYCLING PAPIER
STAMPATO SU CARTA RICICLATA
IMPRESO EN PAPEL RECICLADO