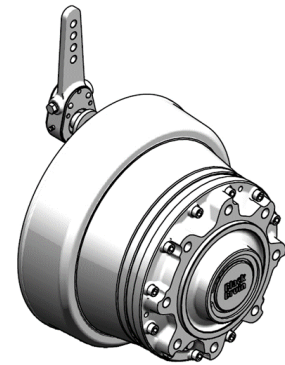

MODEL CODE DESCRIPTION:

A	Frame	=	B250
B	Displacement	=	1600 ccm/rev
C	Displacement control	=	2-speed valve Right side - CW preferred
D	Accessory	=	Drum brake 400x80

TECHNICAL DATA:

Rotating direction	flow direction A to B	CW ²⁾
	flow direction B to A	CCW
Displacement	at full displacement	1600 ccm
	at half displacement	800 ccm
Maximum torque	theoretical	8910 Nm
	with 100 bar	2550 Nm
Brake torque ¹⁾		13500 Nm
Max. operating power	at full displacement	50 kW
	at half displacement	30 kW
Max. rotating speed	at full displacement	125 rpm
	at half displacement	185 rpm
	at freewheeling	500 rpm
Max. engaging speed	(out of freewheeling)	63 rpm
Min. rotating speed	(constant running)	2 rpm
Max. working pressure	peak pressure	350 bar
	intermittent ³⁾	300 bar
Max. case pressure	average	2 bar
	intermittent	10 bar
Pilot pressure for internal valve	valve engaged	7 - 30 bar ⁴⁾
	valve released	0 - 2 bar
Max. flow rate	at full displacement	200 l/min
	at half displacement	150 l/min
Fluid viscosity	recommended	25 - 50 cSt
	minimum	15 cSt
Operating temperature ⁵⁾	recommended	< 70 °C
	maximum	85 °C
Weight		92 kg
Max. load capacity ⁶⁾		5,4 t
Tightening torques ^{7) 8)}	Hub interface	540 Nm M20x1,5 10.9
	Drum brake interface	330 Nm M16x2,0 12.9
	-	-
	-	-

¹⁾ The brake torque is for information only. Braking performance must be ensured by testing and/or certification.

²⁾ Preferred operating direction at half displacement.

³⁾ Intermittent operation: Permissible values for maximum 10 % of every minute.

⁴⁾ If pilot pressure is over 30 bar, the pilot line should be throttled.

⁵⁾ Allowed operating temperature depends on hydraulic fluid viscosity at operating temperature.

⁶⁾ The motor load capacity must be estimated for every application.

⁷⁾ Declared values are for reference only. Always use application specific tightening torques when given.

⁸⁾ Strength class as in ISO 898-1. If using lower strength class, check interface load capacity and tightening torque.

See 'B200 product manual' for more information

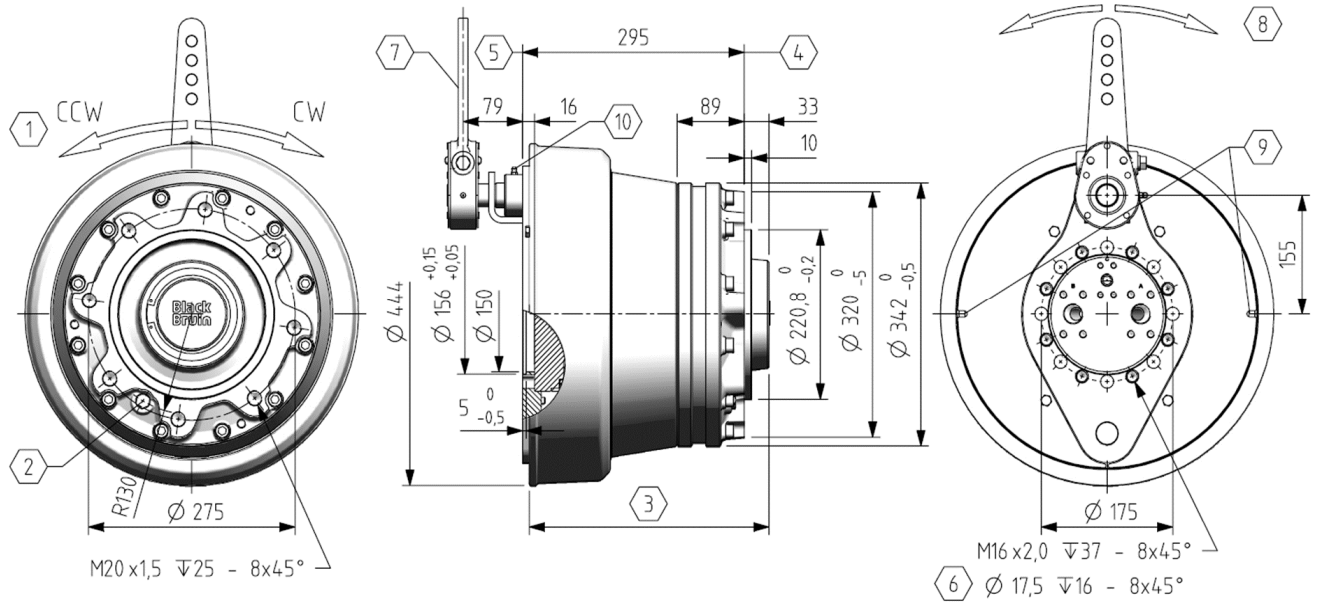
MAIN DIMENSIONS:

- | | |
|--|----------------------------------|
| (1) Rotating direction of the motor housing | (7) Brake lever |
| (2) Air bleed screws (2 pcs) | (8) Brake actuation direction |
| (3) Rotating part of the motor | (9) Brake lining thickness check |
| (4) Hub interface | (10) Brake shaft grease zerker |
| (5) Drum brake interface | |
| (6) Brake frame may be positioned with 45° intervals | (A1) Manual slack adjuster |

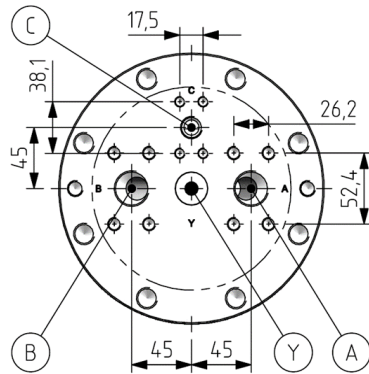
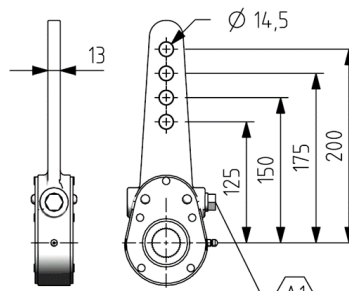
MOTOR HYDRAULIC INTERFACE

BRAKE LEVER

HYDRAULIC CONNECTIONS:

	Port:	Type:	Size:	Pmax: ⁹⁾
	A / B	WORKING LINES		350 bar
		ISO 1179-1	G3/4"	
	C	ISO 6162-1 type 1	1" flange (SAE 3000 psi), M10 screws	
		CASE DRAIN		40 bar
		ISO 1179-1	G3/8"	
Y	ISO 6162-1 type 1	1/2" flange (SAE 3000 psi), M8 screws		
	INTERNAL VALVE PILOT		350 bar	
	ISO 1179-1	G3/4"		

⁹⁾ Max. potential pressure in port. See performance for allowed operating pressure.

See 'B200 product manual' for more information