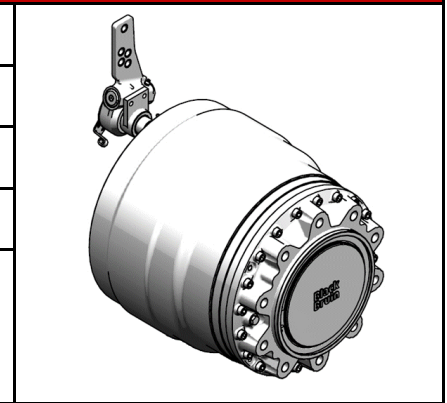

MODEL CODE DESCRIPTION:

A	Frame	=	B260
B	Displacement	=	3150 ccm/rev
C	Displacement control	=	1-speed Fixed displacement
D	Accessory	=	Drum brake 420x220 - Right side

TECHNICAL DATA:

Rotating direction	flow direction A to B	CW
	flow direction B to A	CCW
Displacement	at full displacement	3150 ccm
	at half displacement	-
Maximum torque	theoretical	22600 Nm
	with 100 bar	5010 Nm
Brake torque ¹⁾		20100 Nm
Max. operating power	at full displacement	90 kW
	at half displacement	-
Max. rotating speed	at full displacement	110 rpm
	at half displacement	-
	at freewheeling	400 rpm
Max. engaging speed	(out of freewheeling)	55 rpm
Min. rotating speed	(constant running)	2 rpm
Max. working pressure	peak pressure	450 bar
	intermittent ²⁾	400 bar
Max. case pressure	average	2 bar
	intermittent	10 bar
Pilot pressure for internal valve	valve engaged	-
	valve released	-
Max. flow rate	at full displacement	350 l/min
	at half displacement	-
Fluid viscosity	recommended	25 - 50 cSt
	minimum	15 cSt
Operating temperature	recommended	< 70 °C
	maximum	85 °C
Weight		262 kg
Max. load capacity		12,5 t
Tightening torques ^{3) 4)}	Hub interface	728 Nm M22x1,5 10.9
	Drum brake interface	650 Nm M20x1,5 12.9
	-	-
	-	-

¹⁾ The brake torque is for information only. Braking performance must be ensured by testing and/or certification.

²⁾ Intermittent operation: Permissible values for maximum 10 % of every minute.

³⁾ Declared values are for reference only. Always use application specific tightening torques when given.

⁴⁾ Strength class as in ISO 898-1. If using lower strength class, check interface load capacity and tightening torque.

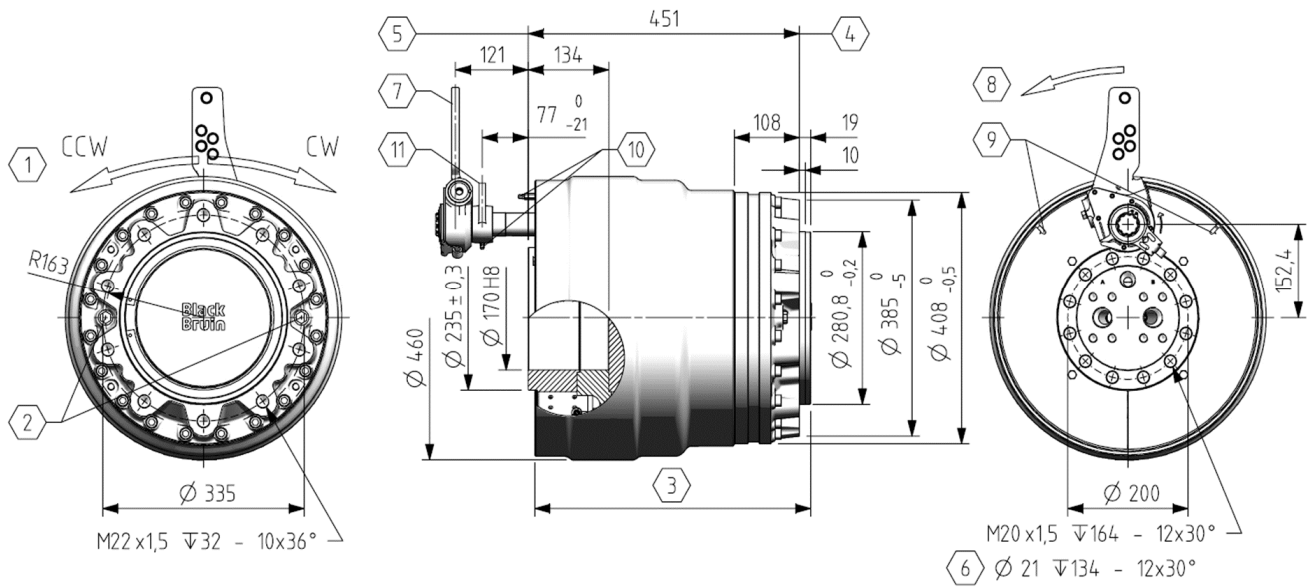
MAIN DIMENSIONS:

- | | |
|------------------------------------------------------|-------------------------------------------|
| (1) Rotating direction of the motor housing | (7) Brake lever |
| (2) Air bleed screws (2 pcs) | (8) Brake actuation direction |
| (3) Rotating part of the motor | (9) Brake lining thickness check |
| (4) Hub interface | (10) Brake shaft grease zerks (2 pcs) |
| (5) Drum brake interface | (11) Brake shaft support |
| (6) Brake frame may be positioned with 30° intervals | |
| | (A1) Manual slack adjuster |
| | (A2) Automatic slack adjuster control arm |
| | (A3) Lever actuation direction |

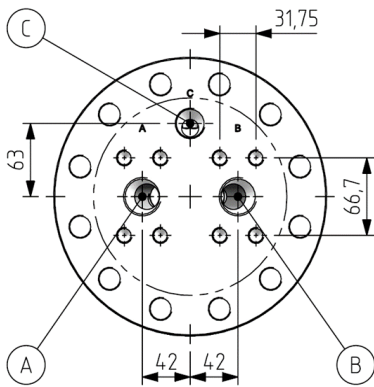
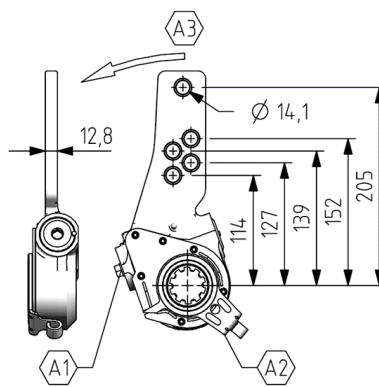
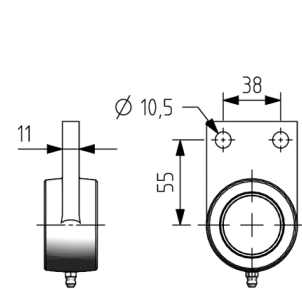
MOTOR HYDRAULIC INTERFACE

BRAKE LEVER

BRAKE SHAFT SUPPORT

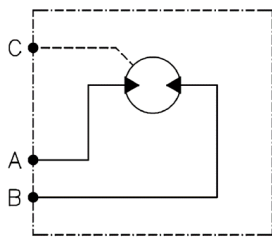
HYDRAULIC CONNECTIONS:

Port:	Type:	Size:	Pmax: ⁵⁾
A / B	WORKING LINES		450 bar
	ISO 1179-1	G1"	
C	ISO 6162-2 type 1	1 1/4" flange (SAE 6000 psi), M14 screws	
	CASE DRAIN		40 bar
	ISO 1179-1	G3/4"	
-	-	-	-

⁵⁾ Max. potential pressure in port. See performance for allowed operating pressure.



See 'B200 product manual' for more information