

# SERVICE MANUAL

## ***INDUSTRIAL ENGINES***

**4TNE92  
4TNE94L  
4TNE98**

**California  
Proposition 65 Warning**

Diesel engine exhaust and some of its constituents are known to the state of California to cause cancer, birth defects, and other reproductive harm.

**California  
Proposition 65 Warning**

Battery posts, terminals, and related accessories contain lead and lead compounds, chemicals known to the state of California to cause cancer and reproductive harm.  
Wash hands after handling.

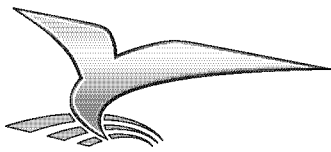

# **TNE series**

## **SERVICE MANUAL**

4TNE92 (EPA Tier2 & 3)  
4TNE94L (EPA Tier2 & 3)  
4TNE98 (EPA Tier2 & 3)

P/N: 0BTNE-G00201

**YAMAHA**  
®

**INDUSTRIAL  
ENGINES**

---

### **English Language Manual Available**

If you would like a copy of this manual in the English language, please contact your local authorized Yanmar industrial engine dealer or distributor. A list of authorized Yanmar industrial engine dealers and distributors can be found at <http://www.yanmar.co.jp/english/index-network.htm>. Note that authorized Yanmar industrial engine dealers and distributors are indicated as “Land” under the “Sales Network” menu.

### **Disclaimers:**

We reserve the right to change specifications and to improve our products without notice or obligation.

Yanmar and **YANMAR** are registered trademarks of Yanmar Co., Ltd. in Japan, the United States and / or other countries.

### **All Rights Reserved:**

No part of this publication may be reproduced or used in any form by any means - graphic, electronic, or mechanical, including photocopying, recording, taping, or information storage and retrieval systems - without the written permission of Yanmar Co., Ltd.

© 2005 Yanmar Co. Ltd.

# TABLE OF CONTENTS

---

Introduction.....	1-1
Yanmar Warranties .....	2-1
Safety .....	3-1
General Service Information.....	4-1
Periodic Maintenance.....	5-1
Engine .....	6-1
Fuel System .....	7-1
Cooling System .....	8-1
Lubrication System.....	9-1
Starter Motor .....	10-1
Alternator.....	11-1
Electric Wiring .....	12-1
Troubleshooting.....	13-1

---

**This Page Intentionally Left Blank**

## Section 1

# INTRODUCTION

---

This manual describes the service procedures for the TNE series indirect injection engines. These engines are certified by the U.S. EPA, California ARB and/or the 97/68/EC Directive for industrial use.

Please use this manual for accurate, quick and safe servicing of the engine. Since the directions in this manual are for a typical engine, some specifications and components may be different from your engine. Refer to the documentation supplied by the optional equipment manufacturer for specific service instructions.

Yanmar products are continuously undergoing improvement. This *Service Manual* might not address possible field modifications to the equipment. Contact an authorized Yanmar industrial engine dealer or distributor for answers to any questions relating to field modifications.

**This Page Intentionally Left Blank**



## Section 2

# YANMAR WARRANTIES

---

## Table of Contents

	Page
Yanmar Limited Warranty.....	2-3
What is Covered by this Warranty? .....	2-3
How Long is the Warranty Period?.....	2-3
What the Engine Owner Must Do:.....	2-3
To Locate an Authorized Yanmar Industrial Engine Dealer or Distributor: .....	2-3
What Yanmar Will Do: .....	2-3
What is Not Covered by this Warranty? .....	2-4
Warranty Limitations:.....	2-4
Warranty Modifications:.....	2-4
Questions: .....	2-4
Customer Registration.....	2-4
Yanmar Co., Ltd. Limited Emission Control System Warranty - USA Only .....	2-5
Your Warranty Rights and Obligations: .....	2-5
Manufacturer's Warranty Period:.....	2-5
Warranty Coverage: .....	2-6
Warranted Systems / Parts Covered by this Warranty:.....	2-6
Exclusions: .....	2-7
Owner's Warranty Responsibilities:.....	2-7

**This Page Intentionally Left Blank**

## YANMAR LIMITED WARRANTY

### What is Covered by this Warranty?

Yanmar warrants to the original retail purchaser that your new Yanmar TNE Series Industrial Engine will be free from defects in material and / or workmanship for the duration of the warranty period.

### How Long is the Warranty Period?

The Yanmar standard limited warranty period begins on the date of the delivery of the new Yanmar TNE Series Industrial Engine to the first retail purchaser and extends for a period of **twenty-four (24) months or two-thousand (2000) engine operation hours**, whichever occurs first.

### What the Engine Owner Must Do:

If you believe your Yanmar engine has experienced a failure due to a defect in material and / or workmanship, you must contact an authorized Yanmar industrial engine dealer or distributor within thirty (30) days of discovering the failure. You must provide proof of ownership of the engine, proof of the date of the engine purchase and delivery, and documentation of the engine operation hours. You are responsible for the transportation of the engine to and from the repair location as designated by Yanmar.

Yanmar strongly recommends you register your engine as soon as possible after purchase in order to facilitate any future warranty matters.

### To Locate an Authorized Yanmar Industrial Engine Dealer or Distributor:

You can locate your nearest authorized Yanmar industrial engine dealer or distributor by visiting the Yanmar Corp., Ltd. web site at:

<http://www.yanmar.co.jp>

- The Japanese language page will be displayed. For English language “click” on “English Page.”
- “Click” on “Network” in the web site heading to view the “Yanmar Worldwide Network.”
- Choose and “Click” on the desired product group.
- “Click” on the Icon closest to your region.
- “Click” on the desired country or Associate company to locate your nearest authorized Yanmar industrial engine dealer or distributor.
- You may also contact Yanmar by clicking on “Inquiry” in the web site heading.

### What Yanmar Will Do:

Yanmar warrants to the original retail purchaser of a new Yanmar engine that Yanmar will make such repairs and / or replacements necessary to correct any defects in materials and / or workmanship discovered during the warranty period. Such repairs and / or replacements will be made at a location designated by Yanmar.

# YANMAR WARRANTIES

---

## *Yanmar Limited Warranty - Continued*

### **What is Not Covered by this Warranty?**

This Warranty does not cover parts affected by or damaged by, but not limited to, accident, misuse, abuse, "Acts of God," neglect, improper installation, improper maintenance, improper storage, the use of unsuitable attachments or parts, the use of contaminated fuels, the use of fuels, oils, lubricants, or fluids other than those recommended in your Yanmar Operation Manual, unauthorized alterations or modifications, ordinary wear and tear, and rust or corrosion. This Warranty does not cover the cost of parts and / or labor required to perform normal / scheduled maintenance on your Yanmar engine. This Warranty does not cover consumable parts such as, but not limited to filters, belts, hoses, fuel injector nozzles, lubricants and cleaning fluids.

### **Warranty Limitations:**

**The foregoing is Yanmar's only obligation to you and your exclusive remedy for breach of warranty.** Failure to follow the requirements for submitting a claim under this Warranty may result in a waiver of all claims for damages and other relief. **In no event shall Yanmar or any authorized industrial engine dealer or distributor be liable for incidental, special or consequential damages.** Such consequential damages may include, but not be limited to, loss of revenue, loan payments, cost of rental of substitute equipment, insurance coverage, storage, lodging, transportation, fuel, mileage and telephone costs. The limitations in this Warranty apply regardless of whether your claims are based on breach of contract, tort (including negligence and strict liability) or any other theory. Any action arising hereunder must be brought within one (1) year after the cause of action accrues or it shall be barred. Some states and countries do not allow certain limitations on warranties or for breach of warranties. **This Warranty gives you specific legal rights, and you may also have other rights which vary from state to state and country to country.** Limitations set forth in this paragraph shall not apply to the extent that they are prohibited by law.

### **Warranty Modifications:**

Except as modified in writing and signed by the parties, this Warranty is and shall remain the complete and exclusive agreement between the parties with respect to warranties, superseding all prior agreements, written and oral, and all other communications between the parties relating to warranties. **No person or entity is authorized to give any other warranty or to assume any other obligation on behalf of Yanmar, either orally or in writing.**

### **Questions:**

If you have any questions or concerns regarding this Warranty, please call or write to the nearest authorized Yanmar industrial engine dealer or distributor or other authorized facility.

## **Customer Registration**

**Customer registration is very important for the original retail purchaser to enable Yanmar to provide the best support for your engine.**

At the time of purchase, Yanmar highly recommends registering the customer's information through website <http://www.yanmar.co.jp> as soon as possible.

*If it is not possible to access the website, please contact the nearest authorized Yanmar industrial engine dealer or distributor.*

# **YANMAR CO., LTD. LIMITED EMISSION CONTROL SYSTEM WARRANTY - USA ONLY**

## **Your Warranty Rights and Obligations:**

### **California**

The California Air Resources Board and Yanmar Co., Ltd. (“Yanmar”) is pleased to explain the emission control system warranty on your off-road compression-ignition model year 2000 or later engine. In California, new heavy-duty off-road engines must be designed, built and equipped to meet the State’s stringent anti-smog standards.

### **All States**

Yanmar warrants that the engine is: (1) designed, built and equipped so as to conform with all applicable emissions regulations, including in California, all applicable regulations adopted by the Air Resources Board; and (2) free from defects in materials and workmanship which cause such engine to fail to conform with applicable emissions regulations for its warranty period.

Yanmar warrants the emission control system on your engine for the periods of time listed in the following table provided there has been no abuse, neglect or improper maintenance of your engine.

Your emission control system may include parts such as the fuel injection system and the air induction system. Also included may be hoses, belts, connectors and other emission-related assemblies.

Where a warrantable condition exists, Yanmar will repair your heavy-duty off-road engine at no charge to you for diagnosis, parts or labor. Warranty services or repairs will be provided at an authorized Yanmar industrial engine dealer or distributor.

## **Manufacturer’s Warranty Period:**

The emission related parts on your model year 2000 or later heavy-duty off-road engines are warranted for the periods listed below. If any emission-related part on your engine is found to be defective during the applicable warranty period, the part will be replaced by Yanmar.

<b>Engine Type</b>	<b>Warranty Period by Number of Years or Hours of Operation</b>
Constant speed engines rated at or above 50 hp SAE (37 kW)	The warranty period is five (5) years or 3,000 hours of use, whichever occurs first. In the absence of a device to measure the hours of use, the engine has a warranty period of five (5) years.
Constant speed engines rated under 50 hp SAE (37 kW) with rated speeds greater than or equal to 3,000 rpm	The warranty period is two (2) years or 1,500 hours of use, whichever occurs first. In the absence of a device to measure the hours of use, the engine has a warranty period of two (2) years.
Constant speed engines rated under 50 hp SAE (37 kW) and engines rated at or above 26 hp SAE (19 kW) with rated speeds less than 3,000 rpm	The warranty period is five (5) years or 3,000 hours of use, whichever occurs first. In the absence of a device to measure the hours of use, the engine has a warranty period of five (5) years.
Engines rated at or above 26 hp SAE (19 kW)	The warranty period is five (5) years or 3,000 hours of use, whichever occurs first. In the absence of a device to measure the hours of use, the engine has a warranty period of five (5) years.
Engines rated under 26 hp SAE (19 kW)	The warranty period is two (2) years or 1,500 hours of use, whichever occurs first. In the absence of a device to measure the hours of use, the engine has a warranty period of two (2) years.

# YANMAR WARRANTIES

---

## *Limited Emission Control System Warranty - USA Only - Continued*

### **Warranty Coverage:**

This warranty is transferable to each subsequent purchaser for the duration of the warranty period. Repair or replacement of any warranted part will be performed at an authorized Yanmar industrial engine dealer or distributor.

Warranted parts not scheduled for replacement as required maintenance in the Operation Manual shall be warranted for the warranty period. Warranted parts scheduled for replacement as required maintenance in the Operation Manual are warranted for the period of time prior to the first scheduled replacement. Any part repaired or replaced under warranty shall be warranted for the remaining warranty period.

During the warranty period, Yanmar is liable for damages to other engine components caused by the failure of any warranted part during the warranty period.

Any replacement part which is functionally identical to the original equipment part in all respects may be used in the maintenance or repair of your engine, and shall not reduce Yanmar's warranty obligations. Add-on or modified parts that are not exempted may not be used. The use of any non-exempted add-on or modified parts shall be grounds for disallowing a warranty.

### **Warranted Systems / Parts Covered by this Warranty:**

This warranty covers engine components that are a part of the emission control system of the engine as delivered by Yanmar to the original retail purchaser. Such components may include the following:

- Fuel Injection System
- Cold Start Enrichment System
- Intake Manifold
- Turbocharger Systems
- Exhaust Manifold
- Positive Crankshaft Ventilation (PCV) System
- PCV Valve
- Oil Filler Cap

## *Limited Emission Control System Warranty - USA Only - Continued*

### **Exclusions:**

Failures other than those arising from defects in material and / or workmanship are not covered by this warranty. The warranty does not extend to the following: malfunctions caused by abuse, misuse, improper adjustment, modification, alteration, tampering, disconnection, improper or inadequate maintenance, improper storage, or use of non-recommended fuels and lubricating oils; accident-caused damage, and replacement of expendable (and / or consumable) items made in connection with scheduled maintenance. Yanmar disclaims any responsibility for incidental or consequential damages such as loss of time, inconvenience, loss of use of equipment / engine or commercial loss.

### **Owner's Warranty Responsibilities:**

**As the heavy-duty off-road engine owner, you are responsible for the performance of the required maintenance listed in your Operation Manual.** Yanmar recommends that you retain all documentation, including receipts, covering maintenance on your heavy-duty off-road engine, but Yanmar cannot deny warranty solely for the lack of receipts, or for your failure to ensure the performance of all scheduled maintenance.

Your engine is designed to operate on diesel fuel only. Use of any other fuel may result in your engine no longer operating in compliance with applicable emissions requirements.

You are responsible for initiating the warranty process. You must present your off-road engine to an authorized Yanmar industrial engine dealer or distributor as soon as a problem exists. The warranty repairs should be completed by the dealer or distributor as expeditiously as possible. If you have any questions regarding your warranty rights and responsibilities, or would like information on the nearest authorized Yanmar industrial engine dealer or distributor, you should contact Yanmar America Corp. at 1-800-872-2867.

**This Page Intentionally Left Blank**



## Section 3

# SAFETY

---

## SAFETY STATEMENTS

Yanmar is concerned for your safety and your machine's condition. Safety statements are one of the primary ways to call your attention to the potential hazards associated with Yanmar TNE engine operation. Follow the precautions listed throughout the manual before operation, during operation and during periodic maintenance procedures for your safety, the safety of others and to protect the performance of your engine. Keep the labels from becoming dirty or torn and replace them if they are lost or damaged. Also, if you need to replace a part that has a label attached to it, make sure you order the new part and label at the same time.



This safety alert symbol appears with most safety statements. It means attention, become alert, your safety is involved! Please read and abide by the message that follows the safety alert symbol.

### **DANGER**

Indicates a hazardous situation which, if not avoided, *will* result in death or serious injury.

### **WARNING**

Indicates a hazardous situation which, if not avoided, *could* result in death or serious injury.

### **CAUTION**

Indicates a hazardous situation which, if not avoided, *could* result in minor or moderate injury.

### **NOTICE**

Indicates a situation which can cause damage to the machine, personal property and / or the environment or cause the equipment to operate improperly.

## SAFETY PRECAUTIONS

### Before You Operate

#### NOTICE



NEVER permit anyone to operate the engine or driven machine without proper training.

- Read and understand this Operation Manual before you operate the machine to ensure that you follow safe operating practices and maintenance procedures.
- Machine safety signs and labels are additional reminders for safe operating and maintenance techniques.
- See your authorized Yanmar industrial engine dealer or distributor for additional training.

### During Operation and Maintenance

#### DANGER

##### SCALD HAZARD!



- NEVER remove the radiator cap if the engine is hot. Steam and hot engine coolant will spurt out and seriously burn you. Allow the engine to cool down before you attempt to remove the radiator cap.
- Securely tighten the radiator cap after you check the radiator. Steam can spurt out during engine operation if the cap is loose.
- ALWAYS check the level of engine coolant by observing the reserve tank.
- Failure to comply will result in death or serious injury.

#### DANGER

##### EXPLOSION HAZARD!



- Keep the area around the battery well ventilated. While the engine is running or the battery is charging, hydrogen gas is produced which can be easily ignited.
- Keep sparks, open flame and any other form of ignition away.
- NEVER check the remaining battery charge by shorting out the terminals. This will result in a spark and may cause an explosion or fire. Use a hydrometer to check the remaining battery charge.
- If the electrolyte is frozen, slowly warm the battery before you recharge it.
- Failure to comply will result in death or serious injury.

#### DANGER

##### FIRE AND EXPLOSION HAZARD!



- Diesel fuel is extremely flammable and explosive under certain conditions.
- When you remove any fuel system component to perform maintenance (such as changing the fuel filter) place an approved container under the opening to catch the fuel.
- NEVER use a shop rag to catch the fuel. Vapors from the rag are extremely flammable and explosive.
- Wipe up any spills immediately.
- Wear eye protection. The fuel system is under pressure and fuel could spray out when you remove any fuel system component.
- NEVER use diesel fuel as a cleaning agent.
- NEVER remove the fuel cap with engine running.

**⚠ DANGER** (Continued)

- Place an approved container under the air bleed port when you prime the fuel system. Never use a shop rag to catch the fuel. Wipe up any spills immediately. **ALWAYS** close the air bleed port after you complete priming the system.
- Wear eye protection. The fuel system is under pressure and fuel could spray out when you open the air bleed port.
- If the unit has an electric fuel pump, turn the key switch to the ON position for 10 to 15 seconds, or until the fuel coming out of the air bleed port is free of bubbles, to allow the electric fuel pump to prime the system.
- If the unit has a mechanical fuel pump, operate the fuel priming pump several times until the fuel coming out of the air bleed port is free of bubbles.
- Only use the key switch to start the engine.
- **NEVER** jump start the engine. Sparks caused by jumping the battery to the starter terminals may cause a fire or explosion.
- Only fill fuel tank with diesel fuel. Filling fuel tank with gasoline may result in a fire.
- **NEVER** refuel with engine running.
- Keep sparks, open flames or any other form of ignition (match, cigarette, static electric source) away when fueling / refueling.
- **NEVER** overfill the fuel tank.
- Fill fuel tank and store fuel in a well-ventilated area only.
- Before you operate the engine, check for fuel leaks. Replace rubberized fuel hoses every two years or every 2000 hours of engine operation, whichever comes first, even if the engine has been out of service. Rubberized fuel lines tend to dry out and become brittle after two years or 2000 hours of engine operation, whichever comes first.
- Failure to comply will result in death or serious injury.

**⚠ DANGER****CRUSH HAZARD!**

- When you need to transport an engine for repair have a helper assist you attach it to a hoist and load it on a truck.
- **NEVER** stand under hoisted engine. If the hoist mechanism fails, the engine will fall on you, causing serious injury or death.
- Failure to comply will result in death or serious injury.

## ⚠ WARNING

### SEVER HAZARD!



- Keep hands and other body parts away from moving / rotating parts such as the cooling fan, flywheel or PTO shaft.
- Wear tight fitting clothing and keep your hair short or tie it back while the engine is running.
- Remove all jewelry before you operate or service the machine.
- NEVER start the engine in gear. Sudden movement of the engine and / or machine could cause death or serious personal injury.
- NEVER operate the engine without the guards in place.
- Before you start the engine make sure that all bystanders are clear of the area.
- Keep children and pets away while the engine is operating.
- Check before starting the engine that any tools or shop rags used during maintenance have been removed from the area.
- Stop the engine before you begin to service it.
- NEVER leave the key in the key switch when you are servicing the engine. Someone may accidentally start the engine and not realize you are servicing it. This could result in a serious injury.
- If you must service the engine while it is operating, remove all jewelry, tie back long hair, and keep your hands, other body parts and clothing away from moving / rotating parts.
- Failure to comply could result in death or serious injury.

## ⚠ WARNING

### EXHAUST HAZARD!



- NEVER operate the engine in an enclosed area such as a garage, tunnel, underground room, manhole or ship's hold without proper ventilation.
- NEVER block windows, vents, or other means of ventilation if the engine is operating in an enclosed area. All internal combustion engines create carbon monoxide gas during operation. Accumulation of this gas within an enclosure could cause illness or even death.
- Make sure that all connections are tightened to specifications after repair is made to the exhaust system.
- Failure to comply could result in death or serious injury.

## ⚠ WARNING

### ALCOHOL AND DRUG HAZARD!



- NEVER operate the engine while you are under the influence of alcohol or drugs.
- NEVER operate the engine when you are feeling ill.
- Failure to comply could result in death or serious injury.

**⚠ WARNING****EXPOSURE HAZARD!**

- Wear personal protective equipment such as gloves, work shoes, eye and hearing protection as required by the task at hand.

- NEVER wear jewelry, unbuttoned cuffs, ties or loose fitting clothing when you are working near moving / rotating parts such as the cooling fan, flywheel or PTO shaft.
- ALWAYS tie long hair back when you are working near moving / rotating parts such as a cooling fan, flywheel, or PTO shaft.
- NEVER operate the engine while wearing a headset to listen to music or radio because it will be difficult to hear warning signals.
- Failure to comply could result in death or serious injury.

**⚠ WARNING****BURN HAZARD!**

- Batteries contain sulfuric acid. NEVER allow battery fluid to come in contact with clothing, skin or eyes. Severe burns could result. ALWAYS wear safety goggles and protective clothing when servicing the battery. If contact with the skin and / or eyes should occur, flush with a large amount of water and obtain prompt medical treatment.

- Failure to comply could result in death or serious injury.

**⚠ WARNING****HIGH PRESSURE HAZARD!**

- Avoid skin contact with high pressure diesel fuel spray caused by a fuel system leak such as a broken fuel injection line. High pressure fuel can penetrate your skin and result in serious injury. If you are exposed to high pressure fuel spray obtain prompt medical treatment.

- NEVER check for a fuel leak with your hands. ALWAYS use a piece of wood or cardboard. Have your authorized Yanmar industrial engine dealer or distributor repair the damage.
- Failure to comply could result in death or serious injury.

**⚠ WARNING****SHOCK HAZARD!**

- Turn off the battery switch (if equipped) or disconnect the negative battery cable before servicing the electrical system.

- Check the electrical harnesses for cracks, abrasions, and damaged or corroded connectors. ALWAYS keep the connectors and terminals clean.
- Failure to comply could result in death or serious injury.

## ⚠ WARNING

### BURN HAZARD!



- If you must drain the engine oil while it is still hot, stay clear of the hot engine oil to avoid being scalded. Make sure you wear eye protection.
- Wait until the engine cools before you drain the engine coolant. Hot engine coolant may splash and burn you.
- Keep your hands, and other body parts, away from hot engine surfaces such as the muffler, exhaust pipe, turbocharger (if equipped) and engine block during operation and shortly after you shut the engine down. These surfaces are extremely hot while the engine is operating and could seriously burn you.
- Failure to comply could result in death or serious injury.

## ⚠ CAUTION

### COOLANT HAZARD!



- Wear eye protection and rubber gloves when you handle Long Life or Extended Life engine coolant. If contact with the eyes or skin should occur, wash with clean water.
- Failure to comply may result in minor or moderate injury.

## ⚠ CAUTION

### FLYING OBJECT HAZARD!



- ALWAYS wear eye protection when servicing engine and when using compressed air or high-pressure water. Dust, flying debris, compressed air, pressurized water or steam may injure your eyes.
- Failure to comply may result in minor or moderate injury.

## NOTICE

- Only use diesel fuels recommended by Yanmar for the best engine performance, to prevent engine damage and to comply with EPA / ARB warranty requirements.
- Only use clean diesel fuel.
- NEVER remove primary strainer from the fuel tank filler port (if equipped). If removed, dirt and debris could get into the fuel system causing it to clog.

## NOTICE

NEVER attempt to adjust the low or high idle speed limit screw. This may impair the safety and performance of the machine and shorten its life. If adjustment is ever required, contact your authorized Yanmar industrial engine dealer or distributor.

## NOTICE

If any problem is noted during the visual check, the necessary corrective action should be taken before you operate the engine.

## NOTICE

NEVER hold the key in the START position for longer than 15 seconds or the starter motor will overheat.

**NOTICE**

The illustrations and descriptions of optional equipment in this manual, such as the operator's console, are for a typical engine installation. Refer to the documentation supplied by the optional equipment manufacturer for specific operation and maintenance instructions.

**NOTICE**

If any indicator illuminates during engine operation stop the engine immediately. Determine the cause and repair the problem before you continue to operate the engine.

**NOTICE**

Observe the following environmental operating conditions to maintain engine performance and avoid premature engine wear:

- Avoid operating in extremely dusty conditions.
- Avoid operating in the presence of chemical gases or fumes.
- Avoid operating in a corrosive atmosphere such as salt water spray.
- NEVER install the engine in a floodplain unless proper precautions are taken to avoid being subject to a flood.
- NEVER expose the engine to the rain.

**NOTICE**

Observe the following environmental operating conditions to maintain engine performance and avoid premature engine wear:

- NEVER run the engine if the ambient temperature is above +104°F (+40°C) or below +5°F (-15°C).
  - ◆ If the ambient temperature exceeds +104°F (+40°C) the engine may overheat and cause the engine oil to break down.
  - ◆ If the ambient temperature falls below +5°F (-15°C) rubber components such as gaskets and seals will harden causing premature engine wear and damage.
  - ◆ Contact your authorized Yanmar industrial engine dealer or distributor if the engine will be operated in either temperature extreme.
- Contact your authorized Yanmar industrial engine dealer or distributor if you need to operate the engine at high altitudes. At high altitudes the engine will lose power, run rough, and produce exhaust gases that exceed the design specifications.

**NOTICE**

- Only use the engine oil specified. Other engine oils may affect warranty coverage, cause internal engine components to seize, or shorten engine life.
- Prevent dirt and debris from contaminating engine oil. Carefully clean the oil cap / dipstick and the surrounding area before you remove the cap.
- NEVER mix different types of engine oil. This may adversely affect the lubricating properties of the engine oil.
- NEVER overfill. Overfilling may result in white exhaust smoke, engine overspeed or internal damage.

### NOTICE

- Only use the engine coolant specified. Other engine coolants may affect warranty coverage, cause an internal build up of rust and scale and / or shorten engine life.
- Prevent dirt and debris from contaminating engine coolant. Carefully clean the radiator cap and the surrounding area before you remove the cap.
- NEVER mix different types of engine coolants. This may adversely affect the properties of the engine coolant.

### NOTICE

- NEVER overfill the engine with engine oil.
- ALWAYS keep the oil level between upper and lower lines on the dipstick.

### NOTICE

For maximum engine life, Yanmar recommends that when shutting the engine down, you allow the engine to idle, without load, for 5 minutes. This will allow the engine components that operate at high temperatures, such as the turbocharger (if equipped) and exhaust system, to cool slightly before the engine itself is shut down.

### NOTICE

NEVER use an engine starting aid such as ether. Engine damage will result.

### NOTICE

Make sure the engine is installed on a level surface. If a continuously running engine is installed at an angle greater than 20° (in any direction) or if an engine runs for short periods of time (less than 3 minutes) at an angle greater than 25° in any direction, engine oil may enter the combustion chamber causing excessive engine speed and generate white smoke. This may cause serious engine damage.

### NOTICE

New Engine Break In:

- On the initial engine start-up, allow the engine to idle for approximately 15 minutes while you check for proper engine oil pressure, diesel fuel leaks, engine oil leaks, coolant leaks, and for proper operation of the indicators and / or gauges.
- During the first hour of operation, vary the engine speed and load on the engine. Short periods of maximum engine speed and load are desirable. Avoid prolonged operation at minimum or maximum engine speeds and loads for the next 4 to 5 hours.
- During the break-in period, carefully observe the engine oil pressure and engine temperature.
- During the break-in period, check the engine oil and coolant levels frequently.

### NOTICE

NEVER engage the starter motor while the engine is running. This may damage the starter motor pinion and / or ring gear.

### NOTICE

- NEVER attempt to modify the engine's design or safety features such as defeating the engine speed limit control or the fuel injection quantity control.
- Failure to comply may impair the engine's safety and performance characteristics and shorten the engine's life. Any alterations to this engine may affect the warranty coverage of your engine. See *Yanmar Limited Warranty on page 2-3*.

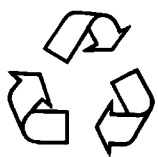

**NOTICE**

Be responsible to the environment. Follow these procedures for hazardous waste disposal. Failure to follow these procedures may seriously harm the environment.

- Follow the guidelines of the EPA or other governmental agency for the proper disposal of hazardous materials such as engine oil, diesel fuel and engine coolant. Consult the local authorities or reclamation facility.
- NEVER dispose of hazardous materials irresponsibly by dumping them into a sewer, on the ground or into ground water or waterways.

**NOTICE**

Protect the air cleaner, turbocharger (if equipped) and electric components from damage when you use steam or use high-pressure water to clean the engine.

**NOTICE**

NEVER use high pressure water or compressed air at greater than 28 psi or a wire brush to clean the radiator fins. Radiator fins damage easily.

**NOTICE**

NEVER attempt to adjust the low or high idle speed limit screw. This may impair the safety and performance of the machine and shorten its life. If the idle speed limit screws require adjustment, see your authorized Yanmar industrial engine dealer or distributor.

**NOTICE**

The tightening torque in the *Standard Torque Chart* (page 5-4) should be applied only to the bolts with a "7" head. (JIS strength classification: 7T)

- Apply 60% torque to bolts that are not listed.
- Apply 80% torque when tightened to aluminum alloy.

**NOTICE**

If any indicator fails to illuminate when the key switch is in the ON position, see your authorized Yanmar industrial engine dealer or distributor for service before operating the engine.

**NOTICE**

Establish a periodic maintenance plan according to the engine application and make sure you perform the required periodic maintenance at intervals indicated. Failure to follow these guidelines will impair the engine's safety and performance characteristics, shorten the engine's life and may affect the warranty coverage on your engine. See *Yanmar Limited Warranty* on page 2-3.

Consult your authorized Yanmar industrial engine dealer or distributor for assistance when checking items marked with a ●.

**NOTICE**

It is important to perform daily checks See *Daily* on page 5-6.

Periodic maintenance prevents unexpected downtime, reduces the number of accidents due to poor machine performance and helps extend the life of the engine.

### **NOTICE**

If no water drips when the fuel filter / water separator drain cock is opened, loosen the air vent screw on the top of the fuel filter / water separator by using a screwdriver to turn it counterclockwise 2-3 turns.

This may occur if the fuel filter / water separator is positioned higher than the fuel level in the fuel tank. After draining the fuel filter / water separator, be sure to tighten the air vent screw.

### **NOTICE**

- When the engine is operated in dusty conditions, clean the air cleaner element more frequently.
- NEVER operate the engine with the air cleaner or element(s) removed. This may cause foreign material to enter the engine and damage it.

### **NOTICE**

The maximum air intake restriction shall be 0.90 psi (6.23 kPa; 635 mm Aq) or less. Clean or replace the air cleaner element if the air intake restriction exceeds the above mentioned value.

### **NOTICE**

NEVER turn off the battery switch (if equipped) or short the battery cables during operation. Damage to the electric system will result.

## Section 4

# GENERAL SERVICE INFORMATION

---

## Table of Contents

	Page
Component Identification.....	4-3
Location of Labels .....	4-3
EPA / ARB Emission Control Regulations - USA Only.....	4-4
Emission Control Labels.....	4-4
EPA / CARB Labels (Typical).....	4-4
The 97/68/EC Directive Certified Engines.....	4-4
Engine Family.....	4-5
Function of Major Engine Components .....	4-6
Function of Cooling System Components .....	4-8
Diesel Fuel .....	4-9
Diesel Fuel Specifications .....	4-9
Filling The Fuel Tank.....	4-10
Priming the Fuel System .....	4-11
Engine Oil.....	4-13
Engine Oil Specifications.....	4-13
Engine Oil Viscosity.....	4-13
Checking Engine Oil.....	4-14
Adding Engine Oil.....	4-14
Engine Oil Capacity (Typical) .....	4-14
Engine Coolant.....	4-15
Engine Coolant Specifications.....	4-15
Filling Radiator With Engine Coolant.....	4-16
Engine Coolant Capacity (Typical) .....	4-17

## GENERAL SERVICE INFORMATION

---

Specifications .....	4-18
Description of Model Number.....	4-18
Engine Speed Specifications.....	4-18
Engine General Specifications .....	4-18
Principal Engine Specifications .....	4-19
4TNE92 EPA Tier2 & Tier3 .....	4-19
4TNE94L EPA Tier2.....	4-20
4TNE94L EPA Tier3.....	4-21
4TNE98 EPA Tier2.....	4-22
4TNE98 EPA Tier3.....	4-23
Engine Service Information .....	4-24
Engine Tuning .....	4-24
Tightening Torques for Standard Bolts and Nuts .....	4-25
Standard Torque Chart .....	4-26
Abbreviations and Symbols.....	4-27
Abbreviations.....	4-27
Symbols.....	4-27
Unit Conversions .....	4-28
Unit Prefixes .....	4-28
Units of Length .....	4-28
Units of Volume .....	4-28
Units of Mass.....	4-28
Units of Force .....	4-28
Units of Torque.....	4-28
Units of Pressure.....	4-28
Units of Power .....	4-28
Units of Temperature.....	4-28

## COMPONENT IDENTIFICATION

Figure 4-1 shows where major engine components are located.

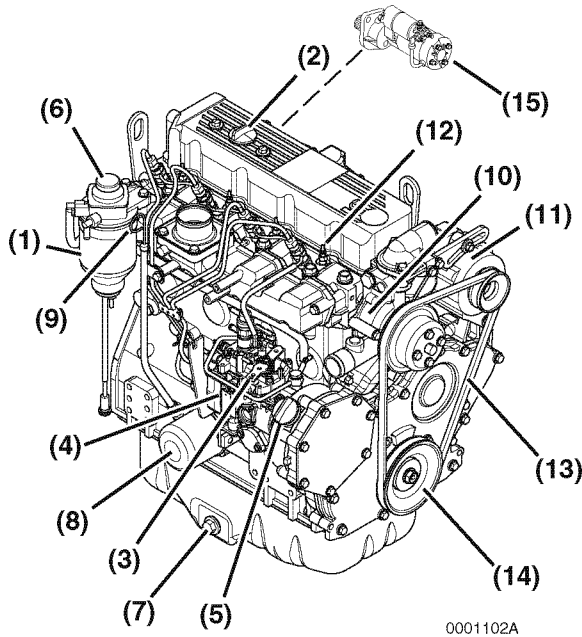
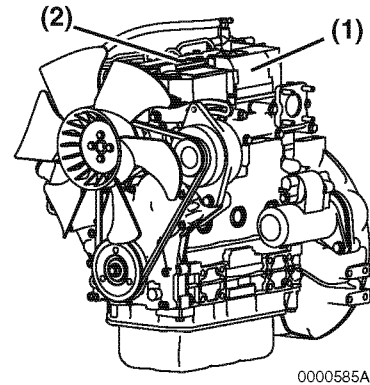

**Figure 4-1**

- |                                  |                          |
|----------------------------------|--------------------------|
| 1. Fuel Filter / Water Separator | 8. Engine Oil Filter     |
| 2. Top Filler Port (Engine Oil)  | 9. Dipstick (Engine Oil) |
| 3. Governor Lever                | 10. Engine Coolant Pump  |
| 4. Fuel Injection Pump           | 11. Alternator           |
| 5. Side Filler Port (Engine Oil) | 12. Glow Plug            |
| 6. Fuel Priming Pump             | 13. V-Belt               |
| 7. Drain Plug (Engine Oil)       | 14. Crankshaft V-Pulley  |
|                                  | 15. Starter Motor        |

## LOCATION OF LABELS

Figure 4-2 shows the location of regulatory and safety labels on Yanmar TNE series engines.

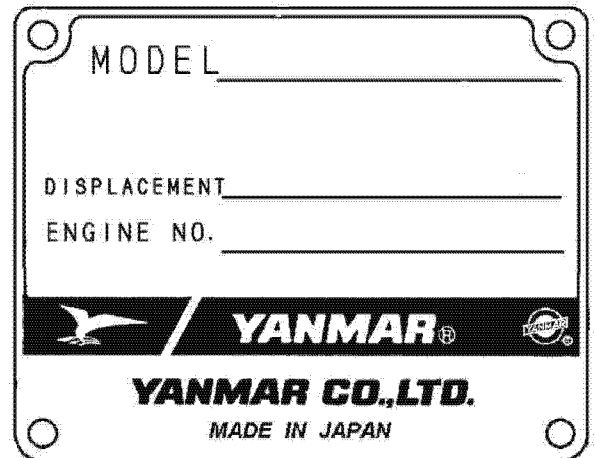

**Figure 4-2**

The typical location of the emission control information label is shown (Figure 4-2, (1)).

Typical location of the engine nameplate is shown (Figure 4-2, (2)).

**Engine Nameplate (Typical)**



## GENERAL SERVICE INFORMATION

### EPA / ARB EMISSION CONTROL REGULATIONS - USA ONLY

Yanmar TNE engines meet Environmental Protection Agency (EPA) (U. S. Federal) emission control standards as well as the California Air Resources Board (ARB, California) regulations. Only engines that conform to ARB regulations can be sold in the State of California.

Refer to the specific EPA / ARB installation (page 5-3) and maintenance (page 5-3) in the *Periodic Maintenance* section of this manual. Also refer to the *Yanmar Co., Ltd. Limited Emission Control System Warranty - USA Only* on page 2-5.

### EMISSION CONTROL LABELS

Since emission control regulations are being issued on a global basis, it is necessary to identify which regulations a particular engine complies with. We have listed several different types of labels you might find on your engine.

### EPA / CARB Labels (Typical)

EMISSION CONTROL INFORMATION	
THIS ENGINE COMPLIES WITH U.S. EPA REGULATIONS FOR <input type="checkbox"/> M.Y. NONROAD DIESEL ENGINES. LOW SULFUR FUEL OR ULTRA LOW SULFUR FUEL ONLY	
ENGINE FAMILY : <input type="text"/>	DISPLACEMENT : <input type="text"/> LITERS
ENGINE MODEL : <input type="text"/>	EMISSION CONTROL SYSTEM : <input type="text"/>
FUEL RATE : <input type="text"/> MM <sup>3</sup> /STROKE @ <input type="text"/> KW / <input type="text"/> RPM <input type="text"/>	
REFER TO OWNER'S MANUAL FOR MAINTENANCE SPECIFICATIONS AND ADJUSTMENTS	
<b>YANMAR. YANMAR CO.,LTD.</b>	

021751-00X

(EPA)

EMISSION CONTROL INFORMATION	
THIS ENGINE COMPLIES WITH U. S. EPA AND CALIFORNIA REGULATIONS FOR <input type="checkbox"/> M.Y. NONROAD/OFF-ROAD DIESEL ENGINES. LOW SULFUR FUEL OR ULTRA LOW SULFUR FUEL ONLY	
ENGINE FAMILY : <input type="text"/>	DISPLACEMENT : <input type="text"/> LITERS
ENGINE MODEL : <input type="text"/>	EMISSION CONTROL SYSTEM : <input type="text"/>
FUEL RATE : <input type="text"/> MM <sup>3</sup> /STROKE @ <input type="text"/> KW / <input type="text"/> RPM <input type="text"/>	
REFER TO OWNER'S MANUAL FOR MAINTENANCE SPECIFICATIONS AND ADJUSTMENTS	
<b>YANMAR. YANMAR CO.,LTD.</b>	

021752-00X

(EPA & CARB)

### THE 97/68/EC DIRECTIVE CERTIFIED ENGINES

The engines described in this manual have been certified by the 97/68/EC Directive.

To identify the engines that meet this certification, the 97/68/EC emission control label is affixed on the engines.

IMPORTANT ENGINE INFORMATION	
THIS ENGINE CONFORMS TO 97/68/EC DIRECTIVE	
ENGINE FAMILY :	<input type="text"/>
ENGINE MODEL :	<input type="text"/>
APPROVAL NUMBER :	<input type="text"/>
<b>YANMAR CO.,LTD.</b>	

(97/68/EC)

## ENGINE FAMILY

The EPA / ARB labels and the 97/68/EC label all have an *Engine Family* field. The following is an explanation of the *Engine Family* designation:

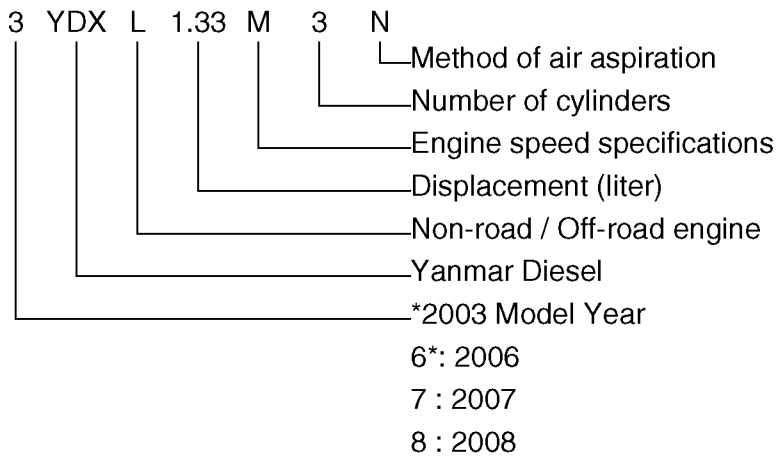

## GENERAL SERVICE INFORMATION

### FUNCTION OF MAJOR ENGINE COMPONENTS

Components	Functions
Air Cleaner	The air cleaner prevents airborne contaminants from entering the engine. Since the air cleaner is application specific, it must be carefully selected by an application engineer. It is not part of the basic engine package as shipped from the Yanmar factory. Periodic replacement of the air cleaner filter element is necessary. See the <i>Periodic Maintenance Schedule on page 5-4</i> for the replacement frequency.
Alternator	The alternator is driven by a V-belt which is powered by the crankshaft V-pulley. The alternator supplies electricity to the engine systems and charges the battery while the engine is running.
Dipstick (Engine Oil)	The engine oil dipstick is used to determine the amount of engine oil in the crankcase.
Electric Fuel Pump	The electric fuel pump makes sure there is a constant supply of diesel fuel to the fuel injection pump. The electric fuel pump is electro-magnetic and runs on 12 VDC. An electric fuel pump may be installed as an option or as standard equipment. Standard equipment may vary based on engine model and specification. If an electric fuel pump is installed, turn the key switch to the ON position for 10 to 15 seconds to prime the fuel system.
Engine Oil Filter	The engine oil filter removes contaminants and sediments from the engine oil. Periodic replacement of the engine oil filter is necessary. See the <i>Periodic Maintenance Schedule on page 5-4</i> for the replacement frequency.
Fuel Filter	The fuel filter removes contaminants and sediments from the diesel fuel. Periodic replacement of the fuel filter is necessary. See the <i>Periodic Maintenance Schedule on page 5-4</i> for the replacement frequency. <b>Please note that the word “diesel” is implied throughout this manual when the word “fuel” is used.</b>
Fuel Filter / Water Separator	The fuel filter / water separator removes contaminants, sediments and water from diesel fuel going to the fuel filter. This is a required component of the fuel system. This is standard equipment with every engine. The separator is installed between the fuel tank and the fuel pump. Periodically drain the water from the fuel filter / water separator using the drain cock at the bottom of the separator.



## GENERAL SERVICE INFORMATION

Components	Functions
Fuel Priming Lever	If the unit has a mechanical fuel pump, a fuel priming lever on the mechanical fuel pump primes the fuel system. The fuel system needs to be primed before you start the engine for the first time, if you run out of fuel, or if fuel system service is performed. To prime the fuel system, operate the fuel priming lever until the cup in the fuel filter is full of fuel.
Fuel Tank	The fuel tank is a reservoir that holds diesel fuel. When fuel leaves the fuel tank it goes to the fuel filter / water separator. Next, fuel is pumped to the fuel filter by the fuel pump. Next the fuel goes to the fuel injection pump. Since fuel is used to keep the fuel injection pump cool and lubricated, more fuel than necessary enters the injection pump. When the injection pump pressure reaches a preset value, a relief valve allows excess fuel to be returned back to the fuel tank. The fuel tank is a required engine component.
Mechanical Fuel Pump	The mechanical fuel pump is a diaphragm type of pump and is installed on the fuel injection pump body. The mechanical fuel pump is driven by a cam on the camshaft of the fuel injection pump. An electric fuel pump is available as an option. The mechanical fuel pump is not installed on the fuel injection pump if the electric fuel pump option is installed.
Side and Top Filler Port (Engine Oil)	You can fill the crankcase with engine oil from <b><i>either the side or top filler port</i></b> depending upon which one is most convenient.
Starter Motor	The starter motor is powered by the battery. When you turn the key switch in the operator's console to the START position, the starter motor engages with the ring gear installed on the flywheel and starts the flywheel in motion.

## FUNCTION OF COOLING SYSTEM COMPONENTS

Components	Functions
Cooling System	<p>The TNE engine is liquid-cooled by means of a cooling system. The cooling system consists of a radiator, radiator cap, engine cooling fan, engine coolant pump, thermostat, and reserve tank.</p> <p><b>Note that all cooling system components are required for proper engine operation. Since some of the components are application specific, they must be carefully selected by an application engineer. The application specific items are not part of the basic engine package as shipped from the Yanmar factory.</b></p>
<ul style="list-style-type: none"> <li>• Engine Cooling Fan</li> </ul>	<p>The engine cooling fan is driven by a V-belt which is powered by the crankshaft V-pulley. The purpose of the engine cooling fan is to circulate air through the radiator.</p>
<ul style="list-style-type: none"> <li>• Engine Coolant Pump</li> </ul>	<p>The engine coolant pump circulates the engine coolant through the cylinder block and cylinder head and returns the engine coolant to the radiator.</p>
<ul style="list-style-type: none"> <li>• Radiator</li> </ul>	<p>The radiator acts as a heat exchanger. As the engine coolant circulates through the cylinder block it absorbs heat. The heat in the engine coolant is dissipated in the radiator. As the engine cooling fan circulates air through the radiator, the heat is transferred to the air.</p>
<ul style="list-style-type: none"> <li>• Radiator Cap</li> </ul>	<p>The radiator cap controls the cooling system pressure. The cooling system is pressurized to raise the boiling point of the engine coolant. As the engine coolant temperature rises, the system pressure and the coolant volume increases. When the pressure reaches a preset value, the release valve in the radiator cap opens and the excess engine coolant flows into the reserve tank. As the engine coolant temperature is reduced, the system pressure and volume is reduced and the vacuum valve in the radiator cap opens allowing engine coolant to flow from the reserve tank back into the radiator.</p>
<ul style="list-style-type: none"> <li>• Reserve Tank</li> </ul>	<p>The reserve tank contains the overflow of engine coolant from the radiator. If you need to add engine coolant to the system, add it to the reserve tank, not the radiator.</p>
<ul style="list-style-type: none"> <li>• Thermostat</li> </ul>	<p>A thermostat is placed in the cooling system to prevent engine coolant from circulating into the radiator until the engine coolant temperature reaches a preset temperature. When the engine is cold, no engine coolant flows through the radiator. Once the engine reaches its operating temperature the thermostat opens. By letting the engine warm up as quickly as possible, the thermostat reduces engine wear, deposits and emissions.</p>

## DIESEL FUEL

### Diesel Fuel Specifications

Diesel fuel should comply with the following specifications. The table lists several worldwide specifications for diesel fuels.

Diesel Fuel Specification	Location
ASTM D975 No. 1D S15, S500 No. 2D S15, S500	USA
EN590:96	European Union
ISO 8217 DMX	International
BS 2869-A1 or A2	United Kingdom
JIS K2204 Grade No.2	Japan
KSM-2610	Korea
GB252	China

### Additional Technical Fuel Requirements

- The fuel cetane number should be equal to 45 or higher.
- The sulfur content must not exceed 0.5% by volume. Less than 0.05% is preferred. Especially in U.S.A. and Canada, Low Sulfur (300-500mg/kg sulfur content) or Ultra Low Sulfur fuel should be used.
- Bio-Diesel fuels. See *Bio-Diesel Fuels on page 4-9*.
- NEVER mix kerosene, used engine oil, or residual fuels with the diesel fuel.
- Water and sediment in the fuel should not exceed 0.05% by volume.
- Keep the fuel tank and fuel-handling equipment clean at all times.
- Poor quality fuel can reduce engine performance and / or cause engine damage.
- Fuel additives are not recommended. Some fuel additives may cause poor engine performance. Consult your Yanmar representative for more information.

- Ash content not to exceed 0.01% by volume.
- Carbon residue content not to exceed 0.35% by volume. Less than 0.1% is preferred.
- Total aromatics content should not exceed 35% by volume. Less than 30% is preferred.
- PAH (polycyclic aromatic hydrocarbons) content should be below 10% by volume.
- Metal content of Na, Mg, Si, and Al should be equal to or lower than 1 mass ppm. (Test analysis method JPI-5S-44-95)
- Lubricity: Wear mark of WS1.4 should be Max. 0.018 in (460 µm) at HFRR test.

### Bio-Diesel Fuels

In Europe and in the United States, as well as some other countries, non-mineral oil based fuel resources such as RME (Rapeseed Methyl Ester) and SOME (Soybean Methyl Ester), collectively known as FAME (Fatty Acid Methyl Esters), are being used as extenders for mineral oil derived diesel fuels.

Yanmar approves the use of bio-diesel fuels that do not exceed a blend of 5% (by volume) of FAME with 95% (by volume) of approved mineral oil derived diesel fuel. Such bio-diesel fuels are known in the marketplace as B5 diesel fuels.

### These B5 diesel fuels must meet certain requirements.

1. The bio-fuels must meet the minimum specifications for the country in which they are used.
  - In Europe, bio-diesel fuels must comply with the European Standard EN14214.
  - In the United States, bio-diesel fuels must comply with the American Standard ASTM D-6751.
2. Bio-fuels should be purchased only from recognized and authorized diesel fuel suppliers.

## GENERAL SERVICE INFORMATION

### Precautions and concerns regarding the use of bio-fuels:

1. Free methanol in FAME may result in corrosion of aluminum and zinc FIE components.
2. Free water in FAME may result in plugging of fuel filters and increased bacterial growth.
3. High viscosity at low temperatures may result in fuel delivery problems, injection pump seizures, and poor injection nozzle spray atomization.
4. FAME may have adverse effects on some elastomers (seal materials) and may result in fuel leakage and dilution of the engine lubricating oil.
5. Even bio-diesel fuels that comply with a suitable standard as delivered, will require additional care and attention to maintain the quality of the fuel in the equipment or other fuel tanks. It is important to maintain a supply of clean, fresh fuel. Regular flushing of the fuel system, and / or fuel storage containers, may be necessary.
6. The use of bio-diesel fuels that do not comply with the standards as agreed to by the diesel engine manufacturers and the diesel fuel injection equipment manufacturers, or bio-diesel fuels that have degraded as per the precautions and concerns above, may affect the warranty coverage of your engine. See *Yanmar Co., Ltd. Limited Emission Control System Warranty - USA Only on page 2-5.*

### Filling The Fuel Tank

**⚠ DANGER**

#### **FIRE AND EXPLOSION HAZARD!**



- Diesel fuel is extremely flammable and explosive under certain conditions.

- Only fill fuel tank with diesel fuel. Filling fuel tank with gasoline may result in a fire.
- NEVER refuel with engine running.
- Wipe up all spills immediately.
- Keep sparks, open flames or any other form of ignition (match, cigarette, static electric source) away when fueling / refueling.
- NEVER overfill the fuel tank.
- Fill fuel tank and store fuel in a well-ventilated area only.
- Be sure to place the diesel fuel container on the ground when transferring diesel fuel from the pump to the container. Hold the hose nozzle firmly against the side of the container while filling it. This prevents static electricity build-up which could cause sparks and ignite fuel vapors.
- NEVER place diesel fuel or other flammable material such as oil, hay or dried grass close to the engine during engine operation or shortly after shut down.
- Before you operate the engine, check for fuel leaks. Replace rubberized fuel hoses every two years or every 2000 hours of engine operation, whichever comes first, even if the engine has been out of service. Rubberized fuel lines tend to dry out and become brittle after two years or 2000 hours of engine operation, whichever comes first.
- Failure to comply will result in death or serious injury.

**NOTICE**

- Only use diesel fuels recommended by Yanmar for the best engine performance, to prevent engine damage and to comply with EPA / ARB warranty requirements.
- Only use clean diesel fuel.
- NEVER remove primary strainer from the fuel tank filler port (if equipped). If removed, dirt and debris could get into the fuel system causing it to clog.

Note that a typical fuel tank is shown. The fuel tank on your equipment may be different.

1. Clean the area around the fuel cap (Figure 4-2, (1)).
2. Remove the fuel cap (Figure 4-2, (1)) from the fuel tank (Figure 4-2, (2)).
3. Observe the fuel level sight gauge (Figure 4-2, (3)) and stop fueling when gauge shows fuel tank is full. NEVER overfill the fuel tank.
4. Replace the fuel cap (Figure 4-2, (1)) and hand tighten. Over-tightening the fuel cap will damage it.

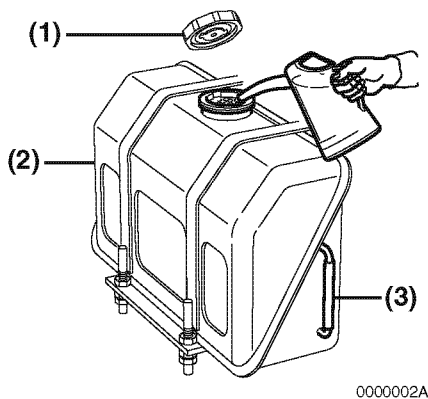

Figure 4-3

Priming the Fuel System

**⚠ DANGER**

**FIRE AND EXPLOSION HAZARD!**



- Diesel fuel is extremely flammable and explosive under certain conditions.

- Place an approved container under the air bleed port when you prime the fuel system. Never use a shop rag to catch the fuel. Wipe up any spills immediately. ALWAYS close the air bleed port after you complete priming the system.
- Wear eye protection. The fuel system is under pressure and fuel could spray out when you open the air bleed port.
- If the unit has an electric fuel pump, turn the key switch to the ON position for 10 to 15 seconds, or until the fuel coming out of the air bleed port is free of bubbles, to allow the electric fuel pump to prime the system.
- If the unit has a mechanical fuel pump, operate the fuel priming pump several times until the fuel coming out of the air bleed port is free of bubbles.
- Failure to comply will result in death or serious injury.

## GENERAL SERVICE INFORMATION

### NOTICE

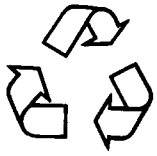

Be responsible to the environment. Follow these procedures for hazardous waste disposal. Failure to follow these procedures may seriously harm the environment.

- Follow the guidelines of the EPA or other governmental agency for the proper disposal of hazardous materials such as engine oil, diesel fuel and engine coolant. Consult the local authorities or reclamation facility.
- NEVER dispose of hazardous materials irresponsibly by dumping them into a sewer, on the ground or into ground water or waterways.

The fuel system needs to be primed under certain conditions.

- Before starting the engine for the first time.
- After running out of fuel and fuel has been added to the fuel tank.
- After fuel system maintenance such as changing the fuel filter and draining the fuel filter / water separator, or replacing a fuel system component.

To prime the fuel system on engines equipped with an electric fuel pump:

1. Place an approved container under the air bleed port.
2. Loosen the air bleed port 2 or 3 turns.
3. Turn the key to the ON position for 10 to 15 seconds or until the fuel coming out of the air bleed port is free of bubbles.
4. Tighten the air bleed port.
5. Wipe up any spills and properly dispose of fuel.
6. NEVER use the starter motor to crank the engine in order to prime the fuel system. This may cause the starter motor to overheat and damage the coils, pinion and / or ring gear.

To prime the fuel system on engines not equipped with an electric fuel system:

1. Place an approved container under the air bleed port.
2. Loosen the air bleed port (**Figure 4-4, (1)**) 2 or 3 turns.
3. Operate the fuel priming pump (**Figure 4-4, (2)**) until the fuel coming out of the air bleed port is free of bubbles.
4. Tighten the air bleed port.
5. Wipe up any spills and properly dispose of fuel.
6. NEVER use the starter motor to crank the engine in order to prime the fuel system. This may cause the starter motor to overheat and damage the coils, pinion and / or ring gear.

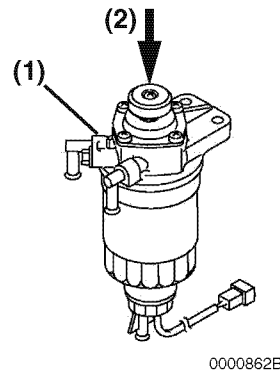

0000862B

**Figure 4-4**

## ENGINE OIL

### NOTICE

- Only use the engine oil specified. Other engine oils may affect warranty coverage, cause internal engine components to seize, or shorten engine life.
- Prevent dirt and debris from contaminating engine oil. Carefully clean the oil cap / dipstick and the surrounding area before you remove the cap.
- NEVER mix different types of engine oil. This may adversely affect the lubricating properties of the engine oil.
- NEVER overfill. Overfilling may result in white exhaust smoke, engine overspeed or internal damage.

### Engine Oil Specifications

Use an engine oil that meets or exceeds the following guidelines and classifications:

#### Service Categories

- API Service Categories CD or higher
- ACEA Service Categories E-3, E-4, and E-5
- JASO Service Category DH-1

#### Definitions

- API Classification (American Petroleum Institute)
- ACEA Classification (Association des Constructeurs Européens d'Automobiles)
- JASO (Japanese Automobile Standards Organization)

Note:

1. Be sure the engine oil, engine oil storage containers, and engine oil filling equipment are free of sediments and water.

2. Change the engine oil after the first 50 hours of operation and then at every 250 hours thereafter.
3. Select the oil viscosity based on the ambient temperature where the engine is being operated. See the SAE Service Grade Viscosity Chart (**Figure 4-5**).
4. Yanmar does not recommend the use of engine oil "additives."

### Additional Technical Engine oil Requirements:

The engine oil must be changed when the Total Base Number (TBN) has been reduced to 2.0. TBN (mgKOH/g) test method; JIS K-201-5.2-2 (HCl), ASTM D4739 (HCl).

### Engine Oil Viscosity

Select the appropriate engine oil viscosity based on the ambient temperature and use the SAE Service Grade Viscosity Chart in **Figure 4-5**.

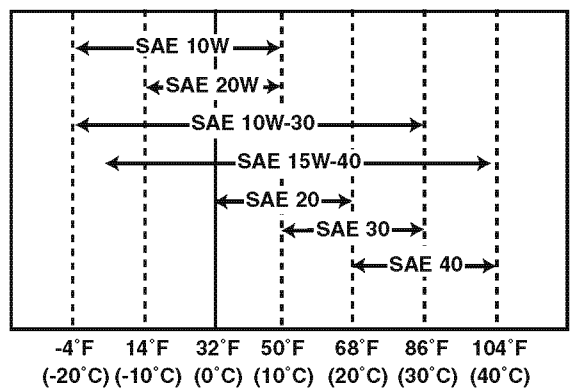

000005

Figure 4-5

## GENERAL SERVICE INFORMATION

### Checking Engine Oil

1. Make sure engine is level.
2. Remove dipstick (**Figure 4-6, (1)**) and wipe with clean cloth.
3. Fully reinsert dipstick.
4. Remove dipstick. The oil level should be between upper (**Figure 4-6, (2)**) and lower (**Figure 4-6, (3)**) lines on the dipstick.
5. Fully reinsert dipstick.

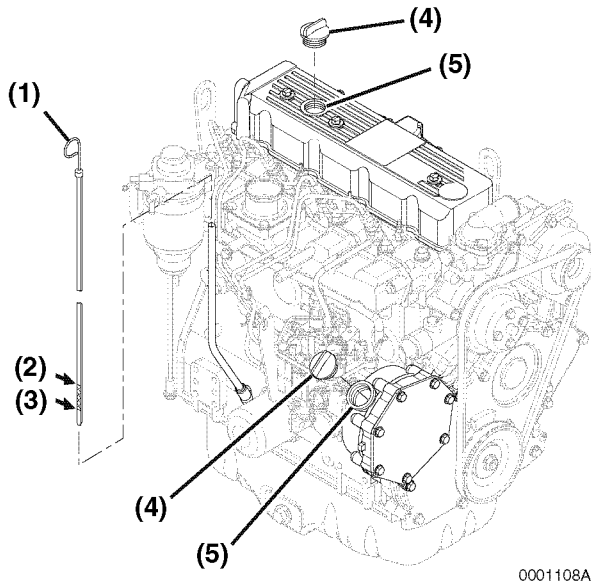

Figure 4-6

0001108A

### Adding Engine Oil

1. Make sure engine is level.
2. Remove oil cap (**Figure 4-6, (4)**).
3. Add indicated amount of engine oil at the top or side engine oil filler port (**Figure 4-6, (5)**).
4. Wait three minutes and check oil level.
5. Add more oil if necessary.
6. Replace oil cap (**Figure 4-6, (4)**) and hand tighten. Over-tightening may damage the cap.

### Engine Oil Capacity (Typical)

Note: These are the engine oil capacities associated with a "Deep Standard" oil pan. Oil capacity will vary dependant upon which optional oil pan is used. Refer to the operation manual provided by the driven machine manufacturer for the actual engine oil capacity of your machine.

The following are typical engine oil capacities for 4TNE92, 4TNE94L and 4TNE98 engines.

Engine Model	Dipstick Upper Limit / Lower Limit
4TNE92	9.7 / 7.6 qt
4TNE94L	(9.2 / 7.2 L)
4TNE98	



## ENGINE COOLANT

### ⚠ DANGER

#### SCALD HAZARD!



- NEVER remove the radiator cap if the engine is hot. Steam and hot engine coolant will spurt out and seriously burn you. Allow the engine to cool down before you attempt to remove the radiator cap.
- Securely tighten the radiator cap after you check the radiator. Steam can spurt out during engine operation if the cap is loose.
- ALWAYS check the level of engine coolant by observing the reserve tank.
- Failure to comply will result in death or serious injury.

### ⚠ WARNING

#### BURN HAZARD!



- Wait until the engine cools before you drain the engine coolant. Hot engine coolant may splash and burn you.
- Failure to comply could result in death or serious injury.

### ⚠ CAUTION

#### COOLANT HAZARD!



- Wear eye protection and rubber gloves when you handle Long Life or Extended Life engine coolant. If contact with the eyes or skin should occur, wash with clean water.
- Failure to comply may result in minor or moderate injury.

### NOTICE

- Only use the engine coolant specified. Other engine coolants may affect warranty coverage, cause an internal build up of rust and scale and / or shorten engine life.
- Prevent dirt and debris from contaminating engine coolant. Carefully clean the radiator cap and the surrounding area before you remove the cap.
- NEVER mix different types of engine coolants. This may adversely affect the properties of the engine coolant.

## Engine Coolant Specifications

Use a Long Life Coolant (LLC) or an Extended Life Coolant (ELC) that meets or exceeds the following guidelines and specifications.

### Alternative Engine Coolant

If an Extended or Long Life Coolant is not available, alternatively, you may use an ethylene glycol or propylene glycol based conventional coolant (green).

Notes:

1. ALWAYS use a mix of coolant and water. NEVER use water only.
2. Mix coolant and water per the mixing instructions on the coolant container.
3. Water quality is important to coolant performance. Yanmar recommends that soft, distilled, or demineralized water be used to mix with coolants.
4. NEVER mix extended or long life coolants and conventional (green) coolants.
5. NEVER mix different types and / or colors of extended life coolants.
6. Replace the coolant every 1000 engine hours or once a year.

# GENERAL SERVICE INFORMATION

## Additional Technical Coolant Specifications:

- ASTM D6210, D4985 (US)
- JIS K-2234 (Japan)
- SAE J814C, J1941, J1034 or J2036 (International)

## Filling Radiator With Engine Coolant

Fill the radiator and reserve tank as follows. This procedure is for filling the radiator for the first time or refilling it after it is flushed. Note that a typical radiator is illustrated.

1. Check to be sure the radiator drain plug is installed and tightened or the drain cock (**Figure 4-7, (1)**) is closed. Also make sure the cylinder block drain plug (**Figure 4-8, (1)**) is installed and tightened.

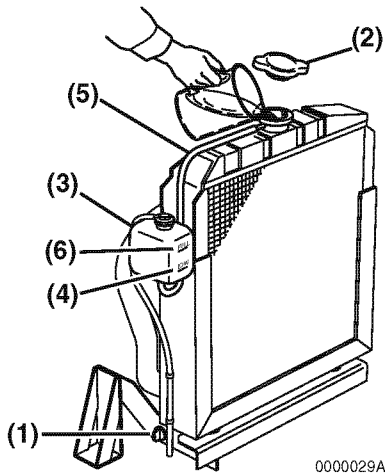

**Figure 4-7**

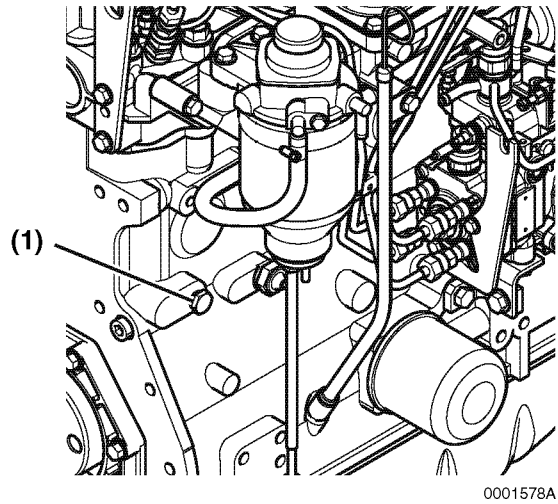

**Figure 4-8**

2. Remove the radiator cap (**Figure 4-7, (2)**) by turning it counter-clockwise about 1/3 of a turn.
3. Pour the engine coolant *slowly* into the radiator until it is even with the lip of the engine coolant filler port. Make sure that air bubbles do not develop as you fill the radiator.
4. Reinstall the radiator cap (**Figure 4-7, (2)**). Align the tabs on the back side of the radiator cap with the notches on the engine coolant filler port. Press down and turn the cap clockwise about 1/3 of a turn.
5. Remove the cap of the reserve tank (**Figure 4-7, (3)**), and fill it to the LOW (COLD) mark (**Figure 4-7, (4)**) with engine coolant. Reinstall the cap.
6. Check the hose (**Figure 4-7, (5)**) that connects the reserve tank (**Figure 4-7, (3)**) to the radiator. Be sure it is securely connected and there are no cracks or damage. If the hose is damaged, engine coolant will leak out instead of going into the reserve tank.

7. Run the engine until it is at operating temperature. Check the level of engine coolant in the reserve tank. When the engine is running and the engine coolant is at normal temperature, the coolant level in the tank should be at the FULL (HOT) mark (**Figure 4-7, (6)**). If the engine coolant is not at the FULL (HOT) mark, add additional engine coolant to the reserve tank to bring the level to the FULL (HOT) mark.

**Engine Coolant Capacity (Typical)**

Note: Capacities listed are for the engine only without a radiator. Refer to the operation manual provided by the driven machine manufacturer for the total cooling system capacity of your specific machine.

The following are typical engine coolant capacities for 4TNE92, 4TNE94L and 4TNE98 engines.

Engine Model	Engine Coolant Capacity
4TNE92 4TNE94L 4TNE98	1.11 gal. (4.2 L)

# GENERAL SERVICE INFORMATION

## SPECIFICATIONS

### Description of Model Number

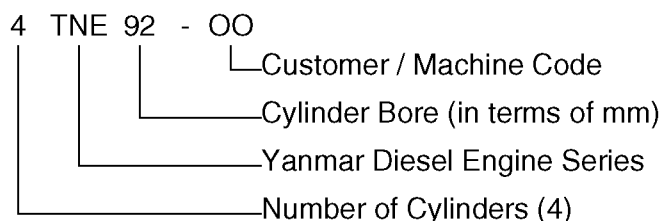

### Engine Speed Specifications

NOTATION	AVAILABLE ENGINE SPEED	INTENDED USES
VM	*2050 ~ 2450 rpm (min <sup>-1</sup> )	Forklift

\*refer to principal engine specifications

VM: Variable Medium Speed

### Engine General Specifications

Type	Vertical Inline, Water Cooled, 4-Cycle Diesel Engine
Combustion System	Indirect Injection
Starting System	Electric Starting
Cooling System	Radiator
Lubricating System	Forced Lubrication With Trochoid Pump
PTO Position	Flywheel End
Direction of Rotation	Counterclockwise Viewed from Flywheel Side

#### Notes:

1. The information described in *Principal Engine Specifications* is for a “standard” engine. To obtain the information for the engine installed in your driven machine, please refer to the manual provided by the driven machine manufacturer.
2. Engine rating conditions are as follows (SAE J1349, ISO 3046/1):
  - Atmospheric Condition: Room temperature 77°F (25°C), Atmospheric pressure 29.53 in Hg (100 kPa, 750 mm Hg), Relative humidity 30%
  - Fuel Temperature at Fuel Injector Pump Inlet: 104°F (40°C)
  - With Cooling Fan, Air Cleaner, Muffler: Yanmar Standard
  - After Engine Break-In Period. Output Allowable Deviation: ± 3%
  - 1 PS = 0.7355 kW
  - 1 hp SAE (Society of Automotive Engineers)= 0.7457 kW

PRINCIPAL ENGINE SPECIFICATIONS

4TNE92 EPA Tier2 & Tier3

Engine Model	4TNE92 EPA Tier2 & Tier3	
Version	VM	
Type	Vertical Inline Diesel Engine	
Combustion System	Indirect Injection, No Turbocharger	
Aspiration	Natural	
No. of Cylinders	4	
Bore x Stroke	3.62 x 3.94 in (92 x 100 mm)	
Displacement	162.3 cu in (2.659 L)	
** Max. Rated Output (Gross)	rpm (min <sup>-1</sup> )	2450
	hp SAE	46.5
	kW	34.7
	PS	47.2
High Idle Speed (Bare Engine)	2725 ± 25 rpm	
Low Idle Speed (Bare Engine)	850 ± 25 rpm	
Engine Weight (Dry)*	496 lb (225 kg)	
PTO Position	Flywheel Side	
Direction of Rotation	Counterclockwise Viewed From Flywheel Side	
Cooling System	Liquid-Cooled With Radiator	
Lubricating System	Forced Lubrication With Trochoid Pump At normal operating speeds, oil pressure is: 42 - 57 psi (0.29 - 0.39 MPa; 3.0 - 4.0 kgf/cm <sup>2</sup> ) At idle, oil pressure is: No less than 18.5 psi (0.13 MPa; 1.3 kgf/cm <sup>2</sup> )	
Starting System	Electric Starting - Starter Motor: DC12V, 3.1 hp (2.3 kW)	
	Alternator: DC12V, 40A	
	Recommended Battery Capacity: 12V, 622 CCA (Cold Cranking Amps)	
Dimensions (L x W x H)*	28.0 x 20.3 x 29.8 in (710 x 516 x 758 mm)	
Engine Oil Pan Capacity	9.7 / 7.6 qt (9.2 / 7.2 L) (Dipstick Upper Limit / Lower Limit)	
Engine Coolant Capacity	1.11 gal (4.2 L) Engine Only	

\* Engine specifications do not include height of lifting eyes nor dimensions or specifications for the Radiator, Muffler, and Air Cleaner.

\*\* The Intake and Exhaust condition of Max. Rated output are

Air Intake Restriction : 250mmAq

Exhaust Gas Restriction : 1000mmAq

\*\*\* The detail specifications are refer to the Specification document which is agreed between both engineering.

# GENERAL SERVICE INFORMATION

## 4TNE94L EPA Tier2

Engine Model	4TNE94L EPA Tier2	
Version	VM	
Type	Vertical Inline Diesel Engine	
Combustion System	Indirect Injection, No Turbocharger	
Aspiration	Natural	
No. of Cylinders	4	
Bore × Stroke	3.70 x 4.33 in (94 x 110 mm)	
Displacement	186.3 cu in (3.053 L)	
** Max. Rated Output (Gross)	rpm (min <sup>-1</sup> )	2450
	hp SAE	61.0
	kW	45.5
	PS	61.9
High Idle Speed (Bare Engine)	2725 ± 25 rpm	
Low Idle Speed (Bare Engine)	850 ± 25 rpm	
Engine Weight (Dry)*	496 lb (225 kg)	
PTO Position	Flywheel Side	
Direction of Rotation	Counterclockwise Viewed From Flywheel Side	
Cooling System	Liquid-Cooled With Radiator	
Lubricating System	Forced Lubrication With Trochoid Pump At normal operating speeds, oil pressure is: 42 - 57 psi (0.29 - 0.39 MPa; 3.0 - 4.0 kgf/cm <sup>2</sup> ) At idle, oil pressure is: No less than 18.5 psi (0.13 MPa; 1.3 kgf/cm <sup>2</sup> )	
Starting System	Electric Starting - Starter Motor: DC12V, 3.1 hp (2.3 kW)	
	Alternator: DC12V, 40A	
	Recommended Battery Capacity: 12V, 622 CCA (Cold Cranking Amps)	
Dimensions (L × W × H)*	28.0 x 20.3 x 29.8 in (710 x 516 x 758 mm)	
Engine Oil Pan Capacity	9.7 / 7.6 qt (9.2 / 7.2 L) (Dipstick Upper Limit / Lower Limit)	
Engine Coolant Capacity	1.11 gal (4.2 L) Engine Only	

\* Engine Specifications Without Radiator, Muffler, and Air Cleaner.

\*\* The Intake and Exhaust condition of Max. Rated output are

Air Intake Restriction : 250mmAq

Exhaust Gas Restriction : 1000mmAq

\*\*\* The detail specifications are refer to the Specification document which is agreed between both engineering.

4TNE94L EPA Tier3

Engine Model	4TNE94L EPA Tier3	
Version	VM	
Type	Vertical Inline Diesel Engine	
Combustion System	Indirect Injection, No Turbocharger	
Aspiration	Natural	
No. of Cylinders	4	
Bore x Stroke	3.70 x 4.33 in (94 x 110 mm)	
Displacement	186.3 cu in (3.053 L)	
** Max. Rated Output (Gross)	rpm (min <sup>-1</sup> )	2200
	hp SAE	47.3
	kW	35.3
	PS	48.0
High Idle Speed (Bare Engine)	2450 ± 25 rpm	
Low Idle Speed (Bare Engine)	810 ± 25 rpm	
Engine Weight (Dry)*	496 lb (225 kg)	
PTO Position	Flywheel Side	
Direction of Rotation	Counterclockwise Viewed From Flywheel Side	
Cooling System	Liquid-Cooled With Radiator	
Lubricating System	Forced Lubrication With Trochoid Pump At normal operating speeds, oil pressure is: 42 - 57 psi (0.29 - 0.39 MPa; 3.0 - 4.0 kgf/cm <sup>2</sup> ) At idle, oil pressure is: No less than 18.5 psi (0.13 MPa; 1.3 kgf/cm <sup>2</sup> )	
Starting System	Electric Starting - Starter Motor: DC12V, 3.1 hp (2.3 kW)	
	Alternator: DC12V, 40A	
	Recommended Battery Capacity: 12V, 622 CCA (Cold Cranking Amps)	
Dimensions (L x W x H)*	28.0 x 20.3 x 29.8 in (710 x 516 x 758 mm)	
Engine Oil Pan Capacity	9.7 / 7.6 qt (9.2 / 7.2 L) (Dipstick Upper Limit / Lower Limit)	
Engine Coolant Capacity	1.11 gal (4.2 L) Engine Only	

\* Engine Specifications Without Radiator, Muffler, and Air Cleaner.

\*\* The Intake and Exhaust condition of Max. Rated output are

Air Intake Restriction : 250mmAq

Exhaust Gas Restriction : 1000mmAq

\*\*\* The detail specifications are refer to the Specification document which is agreed between both engineering.

# GENERAL SERVICE INFORMATION

## 4TNE98 EPA Tier2

Engine Model	4TNE98 EPA Tier2	
Version	VM	
Type	Vertical Inline Diesel Engine	
Combustion System	Indirect Injection, No Turbocharger	
Aspiration	Natural	
No. of Cylinders	4	
Bore × Stroke	3.86 x 4.33 in (98 x 110 mm)	
Displacement	202.5 cu in (3.319 L)	
** Max. Rated Output (Gross)	rpm (min <sup>-1</sup> )	2400
	hp SAE	63.6
	kW	47.4
	PS	64.4
High Idle Speed (Bare Engine)	2725 ± 25 rpm	
Low Idle Speed (Bare Engine)	850 ± 25 rpm	
Engine Weight (Dry)*	496 lb (225 kg)	
PTO Position	Flywheel Side	
Direction of Rotation	Counterclockwise Viewed From Flywheel Side	
Cooling System	Liquid-Cooled With Radiator	
Lubricating System	Forced Lubrication With Trochoid Pump At normal operating speeds, oil pressure is: 42 - 57 psi (0.29 - 0.39 MPa; 3.0 - 4.0 kgf/cm <sup>2</sup> ) At idle, oil pressure is: No less than 18.5 psi (0.13 MPa; 1.3 kgf/cm <sup>2</sup> )	
Starting System	Electric Starting - Starter Motor: DC12V, 3.1 hp (2.3 kW)	
	Alternator: DC12V, 40A	
	Recommended Battery Capacity: 12V, 622 CCA (Cold Cranking Amps)	
Dimensions (L × W × H)*	28.0 x 20.3 x 29.8 in (710 x 516 x 758 mm)	
Engine Oil Pan Capacity	9.7 / 7.6 qt (9.2 / 7.2 L) (Dipstick Upper Limit / Lower Limit)	
Engine Coolant Capacity	1.11 gal (4.2 L) Engine Only	

\* Engine Specifications Without Radiator, Muffler, and Air Cleaner.

\*\* The Intake and Exhaust condition of Max. Rated output are

Air Intake Restriction : 250mmAq

Exhaust Gas Restriction : 1000mmAq

\*\*\* The detail specifications are refer to the Specification document which is agreed between both engineering.



**4TNE98 EPA Tier3**

Engine Model	4TNE98 EPA Tier3	
Version	VM	
Type	Vertical Inline Diesel Engine	
Combustion System	Indirect Injection, No Turbocharger	
Aspiration	Natural	
No. of Cylinders	4	
Bore x Stroke	3.86 x 4.33 in (98 x 110 mm)	
Displacement	202.5 cu in (3.319 L)	
** Max. Rated Output (Gross)	rpm (min <sup>-1</sup> )	2300
	hp SAE	61.7
	kW	46.0
	PS	62.5
High Idle Speed (Bare Engine)	2725 ± 25 rpm	
Low Idle Speed (Bare Engine)	850 ± 25 rpm	
Engine Weight (Dry)*	496 lb (225 kg)	
PTO Position	Flywheel Side	
Direction of Rotation	Counterclockwise Viewed From Flywheel Side	
Cooling System	Liquid-Cooled With Radiator	
Lubricating System	Forced Lubrication With Trochoid Pump At normal operating speeds, oil pressure is: 42 - 57 psi (0.29 - 0.39 MPa; 3.0 - 4.0 kgf/cm <sup>2</sup> ) At idle, oil pressure is: No less than 18.5 psi (0.13 MPa; 1.3 kgf/cm <sup>2</sup> )	
Starting System	Electric Starting - Starter Motor: DC12V, 3.1 hp (2.3 kW)	
	Alternator: DC12V, 40A	
	Recommended Battery Capacity: 12V, 622 CCA (Cold Cranking Amps)	
Dimensions (L x W x H)*	28.0 x 20.3 x 29.8 in (710 x 516 x 758 mm)	
Engine Oil Pan Capacity	9.7 / 7.6 qt (9.2 / 7.2 L) (Dipstick Upper Limit / Lower Limit)	
Engine Coolant Capacity	1.11 gal (4.2 L) Engine Only	

\* Engine Specifications Without Radiator, Muffler, and Air Cleaner.

\*\* The Intake and Exhaust condition of Max. Rated output are

Air Intake Restriction : 250mmAq

Exhaust Gas Restriction : 1000mmAq

\*\*\* The detail specifications are refer to the Specification document which is agreed between both engineering.

## GENERAL SERVICE INFORMATION

## ENGINE SERVICE INFORMATION

### Engine Tuning

Inspection Item		Standard	Limit
Intake / Exhaust Valve Gap		0.006 - 0.010 in (0.15 - 0.25 mm)	-
Fuel Injection Pressure		1711 - 1842 psi (11.8 - 12.7 MPa 120 - 130 kgf / cm <sup>2</sup> )	-
Fuel Injection Timing with Plunger Lifted 0.039 in (1 mm)		6°±1°ATDC	-
Compression Pressure at 250 rpm (250 min <sup>-1</sup> )		425 - 428 psi (2.93 - 2.95 MPa 29 - 31 kgf / cm <sup>2</sup> )	341 psi (2.35 MPa 24 kgf / cm <sup>2</sup> )
Lubricating Oil Pressure	Max. (when cold)	86 psi (0.59 MPa, 6.0 kgf/cm <sup>2</sup> )	-
	At rated output	42 - 57 psi (0.29 - 0.39 MPa, 2.96 - 3.98 kgf/cm <sup>2</sup> )	-
	When idling	8.5 psi (0.06 MPa, 0.6 kgf/cm <sup>2</sup> ) or greater	-
Thermostat	Valve Opening Temperature		Full Opening Lift Temperature
	160°F (71°C)		0.32 in (8 mm) or Above 185°F (85°C)

**TIGHTENING TORQUES FOR STANDARD BOLTS AND NUTS**

Item	Nominal Thread Diameter x Pitch	Tightening Torque	Remarks
Hexagon Bolt (7T) and Nut	M6 x 1.0 mm	7 to 9 ft lbs (87 to 104 in lbs, 9.8 to 11.8 N·m, 1.0 to 1.2 kgf·m)	Use 80% of the value at left when the tightening part is aluminum. Use 60% of the value at left for 4T bolts and lock nuts.
	M8 x 1.25 mm	17 to 21 ft lbs (200 to 251 in lbs, 22.6 to 28.4 N·m, 2.3 to 2.9 kgf·m)	
	M10 x 1.5 mm	33 to 40 ft lbs (44.1 to 53.9 N·m, 4.5 to 5.5 kgf·m)	
	M12 x 1.75 mm	58 to 72 ft lbs (78.4 to 98.0 N·m, 8.0 to 10 kgf·m)	
	M14 x 1.5 mm	94 to 108 ft lbs (127.5 to 147.1 N·m, 13 to 15 kgf·m)	
	M16 x 1.5 mm	159 to 174 ft lbs (215.7 to 235.4 N·m, 22 to 24 kgf·m)	
PT PLug	1/8 mm	7 ft lbs (87 in lbs, 9.8 N·m, 1.0 kgf·m)	-
	1/4 mm	14 ft lbs (173 in lbs, 19.6 N·m, 2.0 kgf·m)	
	3/8 mm	22 ft lbs (29.4 N·m, 3.0 kgf·m)	
	1/2 mm	43 ft lbs (58.8 N·m, 6.0 kgf·m)	
Pipe Joint Bolt	M8	9 to 12 ft lbs (112 to 148 in lbs, 12.7 to 16.7 N·m, 1.3 to 1.7 kgf·m)	-
	M10	14 to 19 ft lbs (173 to 225 in lbs, 19.6 to 18.734 N·m, 2.0 to 3.5 kgf·m)	
	M12	18 to 25 ft lbs (24.5 to 34.3 N·m, 2.5 to 3.5 kgf·m)	
	M14	29 to 36 ft lbs (39.2 to 49.0 N·m, 4.0 to 5.0 kgf·m)	
	M16	36 to 43 ft lbs (49.0 to 58.8 N·m, 5.0 to 6.0 kgf·m)	

Note: Lubricating oil is not applied to threaded portion and seat surface.

## GENERAL SERVICE INFORMATION

---

### STANDARD TORQUE CHART

Thread size x Pitch mm		M6x1.0	M8x1.25	M10x1.5	M12x1.75	M14x1.5	M16x1.5
Tightening Torque	in lbs	96.0 ± 9.0	-	-	-	-	-
	ft lbs	-	19.0 ± 2.0	36.0 ± 4.0	65.0 ± 7.0	101.0 ± 7.0	167.0 ± 7.0
	N·m	10.8 ± 1.0	25.5 ± 2.9	49.0 ± 4.9	88.3 ± 9.8	137 ± 9.8	22.6 ± 9.8
	kgf·m	1.1 ± 0.1	2.6 ± 0.3	5.0 ± 0.5	9.0 ± 1.0	14.0 ± 1.5	23.0 ± 2.0

## ABBREVIATIONS AND SYMBOLS

### Abbreviations

<b>A</b>	ampere
<b>AC</b>	alternating current
<b>ACEA</b>	Association des Constructeurs Européens d'Automobilies
<b>Ah</b>	ampere-hour
<b>approx.</b>	approximately
<b>API</b>	American Petroleum Institute
<b>ARB</b>	Air Resources Board
<b>ATDC</b>	after top dead center
<b>BTDC</b>	before top dead center
<b>°C</b>	degree Celsius
<b>CARB</b>	California Air Resources Board
<b>CCA</b>	cold cranking amp
<b>cm</b>	centimeter
<b>cm<sup>3</sup></b>	cubic centimeter
<b>cm<sup>3</sup>/min</b>	cubic centimeter per minute
<b>cu in</b>	cubic inch
<b>DC</b>	direct current
<b>DI</b>	direct injection
<b>DVA</b>	direct volt adapter
<b>EPA</b>	Environmental Protection Agency
<b>ESG</b>	electronic speed governor
<b>°F</b>	degree Fahrenheit
<b>fl oz</b>	fluid ounce (U.S.)
<b>fl oz/min</b>	fluid ounce (U.S.) per minute
<b>ft</b>	foot
<b>ft lb</b>	foot pound
<b>ft lbf/min</b>	foot pound force per minute
<b>g</b>	gram
<b>gal/hr</b>	gallon (U.S.) per hour
<b>gal</b>	gallon (U.S.)
<b>GL</b>	gear lubricant
<b>hp</b>	horsepower (U.S.)
<b>hrs</b>	hours
<b>I.D.</b>	inside diameter
<b>IDI</b>	indirect injection
<b>in</b>	inch
<b>in lb</b>	inch pound
<b>JASO</b>	Japanese Automobile Standards Organization
<b>kg</b>	kilogram

<b>kgf/cm<sup>2</sup></b>	kilogram force per square centimeter
<b>kgf·m</b>	kilogram force meter
<b>km</b>	kilometers
<b>kPa</b>	kilopascal
<b>kW</b>	kilowatt
<b>L</b>	liter
<b>L/hr</b>	liter per hour
<b>lb</b>	pound
<b>lbf</b>	pond force
<b>mL</b>	milliliter
<b>mm</b>	millimeter
<b>MPa</b>	megapascal
<b>mV</b>	millivolt
<b>N</b>	newton
<b>N·m</b>	newton meter
<b>No.</b>	number
<b>O.D.</b>	outside diameter
<b>oz</b>	ounce
<b>PS</b>	horsepower (metric)
<b>psi</b>	pound per square inch
<b>qt</b>	quart (U.S.)
<b>RPM</b>	revolutions per minute
<b>SAE</b>	Society of Automotive Engineers
<b>sec.</b>	second
<b>t</b>	short ton 2000lb
<b>TBN</b>	Total Base Number
<b>TDC</b>	top dead center
<b>V</b>	volt
<b>VAC</b>	volt alternating current
<b>VDC</b>	volt direct current
<b>W</b>	watt

### Symbols

°	angular degree
+	plus
-	minus
±	plus or minus
Ω	ohm
μ	micro
%	percent
~	approximate

# GENERAL SERVICE INFORMATION

## UNIT CONVERSIONS

### Unit Prefixes

Prefix	Symbol	Power
mega	M	x 1,000,000
kilo	k	x 1,000
centi	c	x 0.01
milli	m	x 0.001
micro	μ	x 0.000001

### Units of Length

mile	x	1.6090 = km
ft	x	0.3050 = m
in	x	2.5400 = cm
in	x	25.4000 = mm
km	x	0.6210 = mile
m	x	3.2810 = ft
cm	x	0.3940 = in
mm	x	0.0394 = in

### Units of Volume

gal (U.S.)	x	3.78540 = L
qt (U.S.)	x	0.94635 = L
cu in	x	0.01639 = L
cu in	x	16.38700 = mL
fl oz (U.S.)	x	0.02957 = L
fl oz (U.S.)	x	29.57000 = mL
cm <sup>3</sup>	x	1.00000 = mL
cm <sup>3</sup>	x	0.03382 = fl oz (U.S.)

### Units of Mass

lb	x	0.45360 = kg
oz	x	28.35000 = g
kg	x	2.20500 = lb
g	x	0.03527 = oz

### Units of Force

lbf	x	4.4480 = N
lbf	x	0.4536 = kgf
N	x	0.2248 = lbf
N	x	0.1020 = kgf
kgf	x	2.2050 = lbf
kgf	x	9.8070 = N

### Units of Torque

ft lb	x	1.3558 = N·m
ft lb	x	0.1383 = kgm
in lb	x	0.1130 = N·m
in lb	x	0.0115 = kgm
kgm	x	7.2330 = ft lb
kgm	x	86.8000 = in lb
kgm	x	9.8070 = N·m
N·m	x	0.7376 = ft lb
N·m	x	8.8510 = in lb
N·m	x	0.1020 = kgm

### Units of Pressure

psi	x	0.0689 = bar
psi	x	6.8950 = kPa
psi	x	0.0703 = kg/cm <sup>2</sup>
bar	x	14.5030 = psi
bar	x	100.0000 = kPa
bar	x	29.5300 = in Hg (60°F)
kPa	x	0.1450 = psi
kPa	x	0.0100 = bar
kPa	x	0.0102 = kg/cm <sup>2</sup>
kg/cm <sup>2</sup>	x	98.0700 = psi
kg/cm <sup>2</sup>	x	0.9807 = bar
kg/cm <sup>2</sup>	x	14.2200 = kPa
in Hg (60°)	x	0.0333 = bar
in Hg (60°)	x	3.3770 = kPa
in Hg (60°)	x	0.0344 = kg/cm <sup>2</sup>

### Units of Power

hp (metric or PS)	x	0.9863201 = hp SAE
hp (metric or PS)	x	0.7354988 = kW
hp SAE	x	1.0138697 = hp (metric or PS)
hp SAE	x	0.7456999 = kW
kW	x	1.3596216 = hp (metric or PS)
kW	x	1.3410221 = hp SAE

### Units of Temperature

$$^{\circ}\text{F} = (1.8 \cdot ^{\circ}\text{C}) + 32$$

$$^{\circ}\text{C} = 0.556 \cdot (^{\circ}\text{F} - 32)$$

## Section 5

# PERIODIC MAINTENANCE

---

## Table of Contents

	Page
Precautions .....	5-3
The Importance of Periodic Maintenance.....	5-3
Performing Periodic Maintenance .....	5-3
Yanmar Replacement Parts .....	5-3
Required EPA / ARB Maintenance - USA Only.....	5-3
EPA / ARB Installation Requirements - USA Only .....	5-3
Tightening Fasteners.....	5-4
Standard Torque Chart.....	5-4
Periodic Maintenance Schedule.....	5-4
Periodic Maintenance Procedures .....	5-6
Daily.....	5-6
Every 250 Hours of Operation .....	5-8
Every 500 Hours of Operation .....	5-13
Every 1000 Hours of Operation .....	5-16
Every 2000 Hours of Operation .....	5-20
Every 4000 Hours of Operation .....	5-21

**This Page Intentionally Left Blank**



This section of the *Service Manual* describes the procedures for proper care and maintenance of the engine.

## PRECAUTIONS

### The Importance of Periodic Maintenance

Engine deterioration and wear occurs in proportion to length of time the engine has been in service and the conditions the engine is subject to during operation. Periodic maintenance prevents unexpected downtime, reduces the number of accidents due to poor machine performance and helps extend the life of the engine.

### Performing Periodic Maintenance

#### WARNING

#### EXHAUST HAZARD!



- NEVER operate the engine in an enclosed area such as a garage, tunnel, underground room, manhole or ship's hold without proper ventilation.
- NEVER block windows, vents, or other means of ventilation if the engine is operating in an enclosed area. All internal combustion engines create carbon monoxide gas during operation. Accumulation of this gas within an enclosure could cause illness or even death.
- Make sure that all connections are tightened to specifications after repair is made to the exhaust system.
- Failure to comply could result in death or serious injury.

Perform periodic maintenance procedures in an open, level area free from traffic. If possible, perform the procedures indoors to prevent environmental conditions, such as rain, wind, or snow, from damaging the machine.

## Yanmar Replacement Parts

Yanmar recommends that you use genuine Yanmar parts when replacement parts are needed. Genuine replacement parts help ensure long engine life.

### Required EPA / ARB Maintenance - USA Only

To maintain optimum engine performance and compliance with the Environmental Protection Agency (EPA) Regulations Non-road Engines and the California Air Resources Board (ARB, California), it is essential that you follow the *Periodic Maintenance Schedule on page 5-4 and Periodic Maintenance Procedures which start on page 5-6.*

### EPA / ARB Installation Requirements - USA Only

The following are the installation requirements for the EPA / ARB. Unless these requirements are met, the exhaust gas emissions will not be within the limits specified by the EPA and ARB.

#### Maximum Exhaust Gas Restriction -

EPA Tier2 certified

4TNE92: 1.85 psi (12.7 kPa; 1300 mmAq)

4TNE94L: 3.84 psi (26.5 kPa; 2700 mmAq)

EPA Tier3 certified

4TNE92, 4TNE98: 8.53 psi (58.8 kPa; 6000 mmAq)

**Maximum Air Intake Restriction - 0.90 psi (6.23kPa; 635mm Aq) or less.** Clean or replace the air cleaner element if the air intake restriction exceeds the above mentioned value.

## PERIODIC MAINTENANCE

### Tightening Fasteners

Use the correct amount of torque when you tighten fasteners on the machine. Applying excessive torque may damage the fastener or component and not enough torque may cause a leak or component failure.

#### NOTICE

The tightening torque in the *Standard Torque Chart* (page 5-4) should be applied only to the bolts with a “7” head. (JIS strength classification: 7T)

- Apply 60% torque to bolts that are not listed.
- Apply 80% torque when tightened to aluminum alloy.



### STANDARD TORQUE CHART

Thread size × Pitch mm		M6×1.0	M8×1.25	M10×1.5	M12×1.75	M14×1.5	M16×1.5
Tightening Torque	in lbs	96.0 ± 9.0	-	-	-	-	-
	ft lbs	-	19.0 ± 2.0	36.0 ± 4.0	65.0 ± 7.0	101.0 ± 7.0	167.0 ± 7.0
	N·m	10.8 ± 1.0	25.5 ± 2.9	49.0 ± 4.9	88.3 ± 9.8	137.0 ± 9.8	226.0 ± 9.8
	kgf·m	1.1 ± 0.1	2.6 ± 0.3	5.0 ± 0.5	9.0 ± 1.0	14.0 ± 1.5	23.0 ± 2.0

### PERIODIC MAINTENANCE SCHEDULE

Daily and periodic maintenance is important to keep the engine in good operating condition. The following is a summary of maintenance items by periodic maintenance intervals. Periodic maintenance intervals vary depending on engine application, loads, diesel fuel and engine oil used and are hard to establish definitively. The following should be treated only as a general guideline.

#### NOTICE

Establish a periodic maintenance plan according to the engine application and make sure you perform the required periodic maintenance at intervals indicated. Failure to follow these guidelines will impair the engine's safety and performance characteristics, shorten the engine's life and may affect the warranty coverage on your engine. See *Yanmar Limited Warranty* on page 2-3.

Consult your authorized Yanmar industrial engine dealer or distributor for assistance when checking items marked with a ●.

# PERIODIC MAINTENANCE

○: Check    ◇: Replace    ●: Contact your authorized Yanmar industrial engine dealer or distributor

System	Check Item	Check During Operation	Daily	Periodic Maintenance Interval				
				Every 250 hours	Every 500 hours	Every 1000 hours	Every 2000 hours	Every 4000 hours
Cooling System	Check & Re-fill Engine Coolant		○					
	Check Engine Coolant Temperature Indicator	○						
	Check & Clean Radiator Fins <sup>1</sup>			○ or every 6 weeks				
	Check & Adjust Cooling Fan V-belt	First Check after 50 hours		○ or every 6 weeks				
	Drain, Flush, and Re-fill Cooling System with New Coolant							◇ or every 2 yr. which-ever comes first
Cylinder Head	Adjust Intake / Exhaust Valve Clearance					● or every 6 months		
Electrical Equipment	Check Battery			○ or every 6 weeks				
	Check Battery Indicator	○						
Emission Control Warranty	Inspect, Clean & Test Fuel Injectors, if necessary						● or every 1 year	
Engine Oil	Check Engine Oil Level		○					
	Check Engine Oil Pressure Indicator	○						
	Drain & Fill Engine Oil					● or every 3 months		
	Replace Engine Oil Filter					● or every 3 months		
Engine Speed Control	Check & Adjust Governor Lever & Engine Speed Control				○ or every 3 months			
Fuel	Check & Re-fill Fuel Tank Level		○					
	Check Fuel Filter Indicator	○						
	Drain Fuel Filter / Water Separator		○					
	Check Fuel Filter / Water Separator		○					
	Clean Fuel Filter / Water Separator <sup>1</sup>					○ or every 6 months		
	Replace Fuel Filter <sup>1</sup>						◇ or every 6 months	
Hoses	Inspect or Replace Fuel System & Cooling System Hoses		○					○ or every 2 years
Intake & Exhaust	Clean or Replace Air Cleaner Element <sup>1,2</sup>			○ or every 6 weeks			◇ or every 1 year	
1		Very dirty conditions will require daily check and cleaning.						
2		In dirty or dusty environments, replace at 1000 hours or as needed.						

Note: These procedures are considered normal maintenance and are performed at the owner's expense.

# PERIODIC MAINTENANCE PROCEDURES

### Daily

Perform the following procedures daily.

- Drain Fuel Filter / Water Separator
- Check Fuel Hoses and Engine Coolant Hoses

### Drain Fuel Filter / Water Separator

#### DANGER

#### FIRE AND EXPLOSION HAZARD!



- Diesel fuel is extremely flammable and explosive under certain conditions.
- When you remove any fuel system component to perform maintenance (such as changing the fuel filter) place an approved container under the opening to catch the fuel.
- NEVER use a shop rag to catch the fuel. Vapors from the rag are extremely flammable and explosive.
- Wipe up any spills immediately.
- Wear eye protection. The fuel system is under pressure and fuel could spray out when you remove any fuel system component.
- Failure to comply will result in death or serious injury.

#### WARNING

#### HIGH PRESSURE HAZARD!



- Avoid skin contact with high pressure diesel fuel spray caused by a fuel system leak such as a broken fuel injection line. High pressure fuel can penetrate your skin and result in serious injury. If you are exposed to high pressure fuel spray obtain prompt medical treatment.
- NEVER check for a fuel leak with your hands. ALWAYS use a piece of wood or cardboard. Have your authorized Yanmar industrial engine dealer or distributor repair the damage.
- Failure to comply could result in death or serious injury.

#### NOTICE

If no water drips when the fuel filter / water separator drain cock is opened, loosen the air vent screw on the top of the fuel filter / water separator by using a screwdriver to turn it counterclockwise 2-3 turns.

This may occur if the fuel filter / water separator is positioned higher than the fuel level in the fuel tank. After draining the fuel filter / water separator, be sure to tighten the air vent screw.

## NOTICE

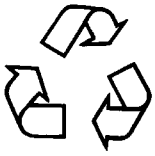

Be responsible to the environment. Follow these procedures for hazardous waste disposal. Failure to follow these procedures may seriously harm the environment.

- Follow the guidelines of the EPA or other governmental agency for the proper disposal of hazardous materials such as engine oil, diesel fuel and engine coolant. Consult the local authorities or reclamation facility.
- NEVER dispose of hazardous materials irresponsibly by dumping them into a sewer, on the ground or into ground water or waterways.

NEVER wait until the scheduled periodic maintenance if the fuel filter indicator comes on.

The fuel filter / water separator contains a sensor to detect the amount of water and contaminants. This sensor sends a signal to an indicator to alert the operator.

Drain the fuel filter / water separator as follows:

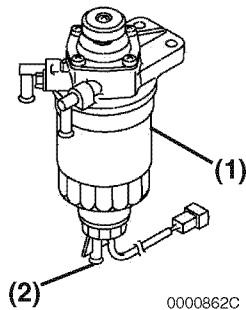

**Figure 5-1**

1. Position an approved container under the fuel filter / water separator (**Figure 5-1, (1)**) to collect the contaminants.
2. Loosen the drain cock (**Figure 5-1, (2)**) at the bottom of the fuel filter / water separator. Drain any water collected inside.
3. Hand tighten the drain cock.
4. Be sure to prime the diesel fuel system when you are done. See *Priming the Fuel System* on page 4-11.

## Check Fuel Hoses and Engine Coolant Hoses

Daily check the fuel system and engine coolant system hoses. If they are cracked or degraded, replace them.

### Every 250 Hours of Operation

Perform the following maintenance every 250 hours of operation.

- Check and Clean Radiator Fins
- Check and Adjust Cooling Fan V-Belt
- Check Battery
- Clean Air Cleaner Element

### Check and Clean Radiator Fins

#### **CAUTION**

#### **FLYING OBJECT HAZARD!**



- ALWAYS wear eye protection when servicing engine and when using compressed air or high-pressure water. Dust, flying debris, compressed air, pressurized water or steam may injure your eyes.

- Failure to comply may result in minor or moderate injury.

Dirt and dust adhering to the radiator fins reduce the cooling performance, causing overheating. Make it a rule to check the radiator fins daily and clean as needed.

Note that a typical radiator is shown in **Figure 5-2** for illustrative purposes only.

- Blow off dirt and dust from fins and radiator with 28 psi (0.19MPa, 2kgf/cm<sup>2</sup>) or less of compressed air (**Figure 5-2, (1)**). Be careful not to damage the fins with the compressed air.
- If there is a large amount of contamination on the fins, apply detergent, thoroughly clean and rinse with tap water.

#### **NOTICE**

NEVER use high pressure water or compressed air at greater than 28 psi or a wire brush to clean the radiator fins. Radiator fins damage easily.

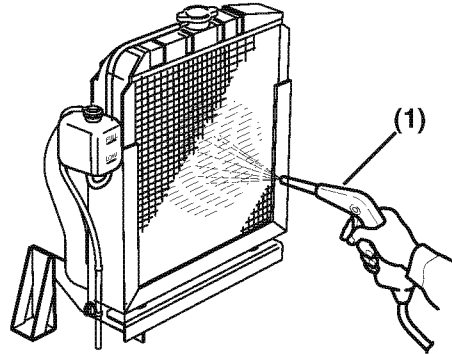

0000085A

**Figure 5-2**

### Check and Adjust Cooling Fan V-belt

The V-belt will slip if it does not have the proper tension. This will prevent the alternator from generating sufficient power. Also, the engine will overheat due to the engine coolant pump pulley slipping. Be sure to check for proper belt tension after the first 50 hours of operation. Thereafter, check the belt tension every 250 hours of operation.

Check and adjust the V-belt tension (deflection) as follows:

1. Press the V-belt down with your thumb with a force of approximately 22 ft lbs (98 N•m, 10 kgf•m) to check the deflection.

There are three positions to check for V-belt tension (**Figure 5-3, (A), (B) and (C)**). You can check the tension at whichever position is the most accessible. The proper deflection of a used V-belt at each position is:

Used V-belt Tension		
A	B	C
3/8 ~1/2 in (10~14 mm)	1/4 ~3/8 in (7~10 mm)	5/16 ~1/2 in (9~13 mm)

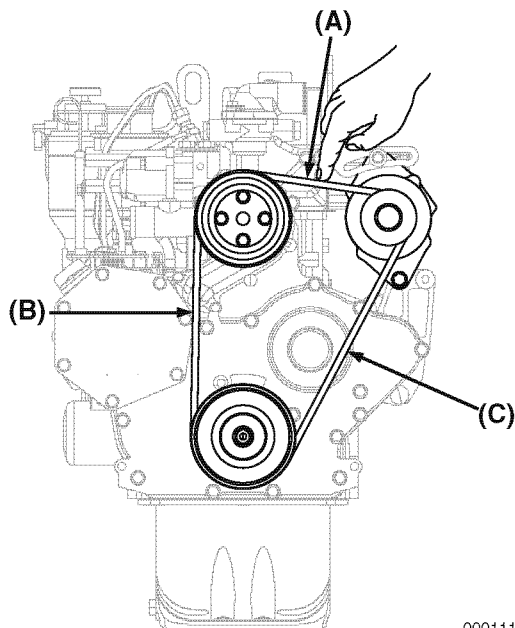
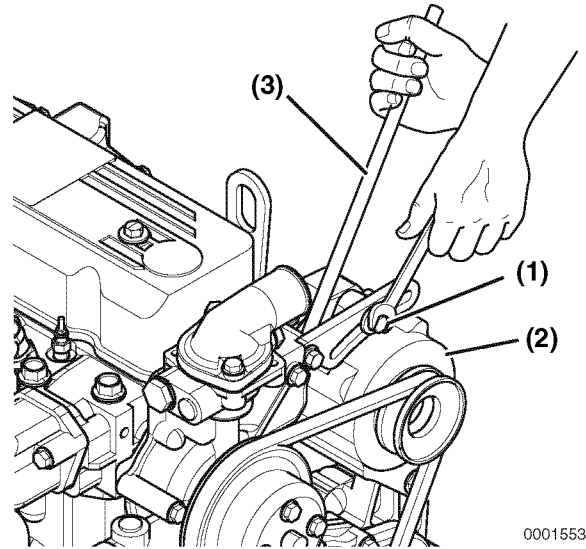

Figure 5-3

0001111A

2. If necessary, adjust the V-belt tension. Loosen the set bolt (**Figure 5-4, (1)**) and move the alternator (**Figure 5-4, (2)**) with a pry bar (**Figure 5-4, (3)**) to tighten the V-belt.



0001553A

Figure 5-4

3. Check the V-belt for cracks, oil or wear. If any of these conditions exist, replace the V-belt.
  - “New V-belt” refers to a V-belt which has been used less than 5 minutes on a running engine.
  - “Used V-belt” refers to a V-belt which has been used on a running engine for 5 minutes or more.
4. Inspect the condition of the used V-belt. There must be clearance (**Figure 5-5, (1)**) between the V-belt and the bottom of the pulley groove. If there is no clearance (**Figure 5-5, (2)**) between the V-belt and the bottom of the pulley groove, replace the V-belt.

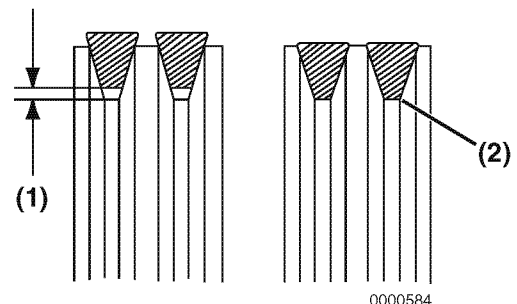

0000584

Figure 5-5

## PERIODIC MAINTENANCE

5. Install the new V-belt. Refer to the table for proper tension.

New V-belt Tension		
A	B	C
5/16 ~7/16 in (8~12 mm)	3/16 ~5/16 in (5~8 mm)	1/4 ~7/16 in (7~11 mm)

6. After adjusting, run the engine for 5 minutes or more. Check the tension again using the specifications for a used V-belt.

Used V-belt Tension		
A	B	C
3/8 ~1/2 in (10~14 mm)	1/4 ~3/8 in (7~10 mm)	5/16 ~1/2 in (9~13 mm)

### Check Battery

#### DANGER

##### **EXPLOSION HAZARD!**



- **NEVER** check the remaining battery charge by shorting out the terminals. This will result in a spark and may cause an explosion or fire. Use a hydrometer to check the remaining battery charge.
- If the electrolyte is frozen, slowly warm the battery before you recharge it.
- Failure to comply will result in death or serious injury.

#### WARNING

##### **BURN HAZARD!**



- Batteries contain sulfuric acid. **NEVER** allow battery fluid to come in contact with clothing, skin or eyes. Severe burns could result. **ALWAYS** wear safety goggles and protective clothing when servicing the battery. If contact with the skin and / or eyes should occur, flush with a large amount of water and obtain prompt medical treatment.
- Failure to comply could result in death or serious injury.

#### **NOTICE**

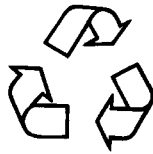

- Be responsible to the environment. Follow these procedures for hazardous waste disposal. Failure to follow these procedures may seriously harm the environment.
- Follow the guidelines of the EPA or other governmental agency for the proper disposal of hazardous materials such as engine oil, diesel fuel and engine coolant. Consult the local authorities or reclamation facility.
  - **NEVER** dispose of hazardous materials irresponsibly by dumping them into a sewer, on the ground or into ground water or waterways.



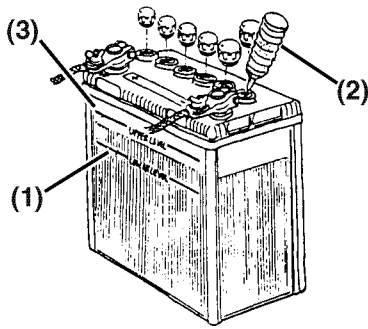

0000067A

**Figure 5-6**

- When the amount of fluid nears the lower limit (**Figure 5-6, (1)**), fill with distilled water (**Figure 5-6, (2)**) so it is at the upper limit (**Figure 5-6, (3)**). If operation continues with insufficient battery fluid, the battery life is shortened, and the battery may overheat and explode. During the summer, check the fluid level more often than specified.
- If the engine cranking speed is so slow that the engine does not start, recharge the battery.
- If the engine still will not start after charging, have your authorized Yanmar industrial engine dealer or distributor check the battery and the engine's starting system.
- If operating the machine where the ambient temperature could drop to 5°F (-15°C) or less, remove the battery from the machine at the end of the day. Store the battery in a warm place until the next use. This will help start the engine easily at low ambient temperatures.

### Clean Air Cleaner Element

Note that a typical air cleaner is shown in **Figure 5-7** and **Figure 5-8** for illustrative purposes only.

The engine performance is adversely affected when the air cleaner element is clogged with dust. Be sure to clean the air filter element periodically.

1. Unlatch and remove the air cleaner cover (**Figure 5-7, (1)**).
2. Remove the element (**Figure 5-7, (2)**) (outer element if equipped with two elements).

### CAUTION

#### FLYING OBJECT HAZARD!



- **ALWAYS** wear eye protection when servicing engine and when using compressed air or high-pressure water. Dust, flying debris, compressed air, pressurized water or steam may injure your eyes.
- Failure to comply may result in minor or moderate injury.

## PERIODIC MAINTENANCE

3. Blow air (**Figure 5-7, (3)**) through the element from the inside out using 42–71 psi (0.29–0.49MPa, 3.0–5.0kgf/cm<sup>2</sup>) compressed air to remove the particulates. Use the lowest possible air pressure to remove the dust without damaging the element.

If the air cleaner is equipped with a double element, *only remove and replace the inner element (Figure 5-8, (1)) if the engine lacks power or the dust indicator actuates (if equipped)*. This is in addition to replacing the outer element.

The inner element should not be removed when cleaning or replacing the outer element. The inner element it is used to prevent dust from entering the engine while servicing the outer element.

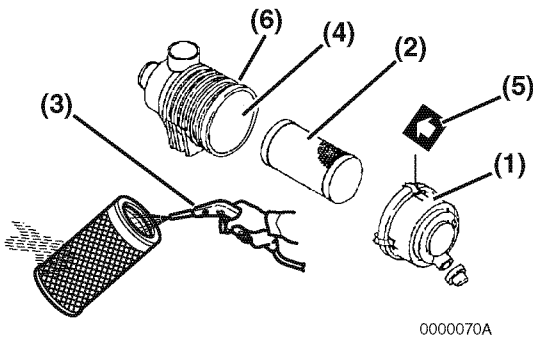

**Figure 5-7**

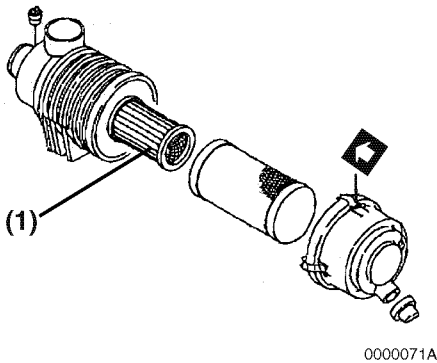

**Figure 5-8**

4. Replace the element with a new one if the element is damaged, excessively dirty or oily.
5. Clean inside of the air cleaner cover.
6. Install the element into the air cleaner case (**Figure 5-7, (4)**).
7. Install the air cleaner cover making sure you match the arrow (**Figure 5-7, (5)**) on the cover with the arrow on the case (**Figure 5-7, (6)**).
8. Latch the air cleaner cover to the case.

### NOTICE

- When the engine is operated in dusty conditions, clean the air cleaner element more frequently.
- NEVER operate the engine with the air cleaner or element(s) removed. This may cause foreign material to enter the engine and damage it.

**Every 500 Hours of Operation**

Perform the following maintenance every 500 hours of operation.

- **Replace Engine Oil and Engine Oil Filter**
- **Check and Adjust the Governor Lever and Engine Speed Control**

**Replace Engine Oil and Engine Oil Filter**

**⚠ WARNING**

**BURN HAZARD!**



- If you must drain the engine oil while it is still hot, stay clear of the hot engine oil to avoid being scalded. Make sure you wear eye protection.

- Failure to comply could result in death or serious injury.

**NOTICE**

- Only use the engine oil specified. Other engine oils may affect warranty coverage, cause internal engine components to seize, or shorten engine life.
- Prevent dirt and debris from contaminating engine oil. Carefully clean the oil cap / dipstick and the surrounding area before you remove the cap.
- NEVER mix different types of engine oil. This may adversely affect the lubricating properties of the engine oil.
- NEVER overfill. Overfilling may result in white exhaust smoke, engine overspeed or internal damage.

**NOTICE**

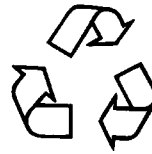

Be responsible to the environment. Follow these procedures for hazardous waste disposal. Failure to follow these procedures may seriously harm the environment.

- Follow the guidelines of the EPA or other governmental agency for the proper disposal of hazardous materials such as engine oil, diesel fuel and engine coolant. Consult the local authorities or reclamation facility.
- NEVER dispose of hazardous materials irresponsibly by dumping them into a sewer, on the ground or into ground water or waterways.

## PERIODIC MAINTENANCE

Change the engine oil every 500 hours of operation. Replace the engine oil filter at the same time.

Drain the engine oil as follows:

1. Make sure the engine is level.
2. Start the engine and bring it up to operating temperature.
3. Stop the engine.
4. Remove the oil filler cap (**Figure 5-9, (1)**) to vent the engine crankcase and to allow the engine oil to drain more easily.
5. Position a container (**Figure 5-10, (1)**) under the engine to collect waste oil.

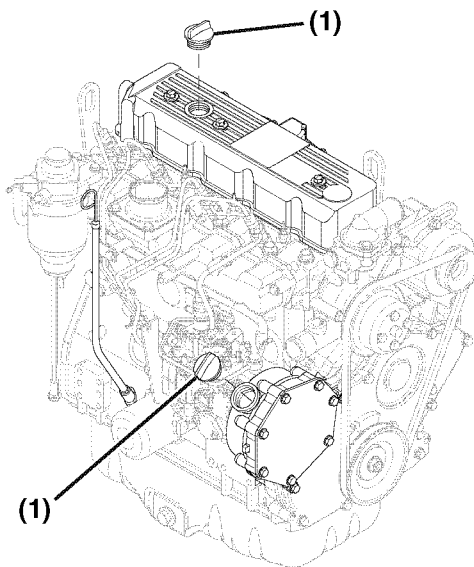

**Figure 5-9**

6. Remove the drain plug (**Figure 5-10, (2)**). Allow oil to drain.

After all oil has been drained from the engine, install the drain plug (**Figure 5-10, (2)**) and tighten to 14-17 ft lbs (19.6-23.5 N•m, 2.0-2.4 kgf•m).

7. Dispose of used oil properly.

Remove the engine oil filter as follows:

1. Turn the engine oil filter (**Figure 5-11, (1)**) counterclockwise (**Figure 5-11, (2)**) using a filter wrench.

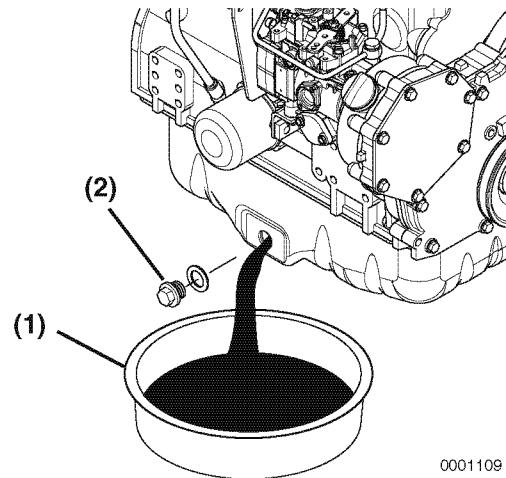

**Figure 5-10**

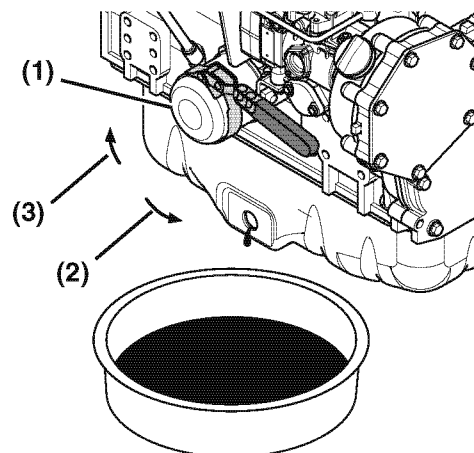

**Figure 5-11**

2. Clean the engine oil filter mounting face.
3. Lightly coat the gasket on the new oil filter with engine oil. Install the new engine oil filter manually by turning it clockwise (**Figure 5-11, (3)**) until it contacts the mounting surface. Tighten an additional 3/4 of a turn using the filter wrench.

Applicable Engine Oil Filter Part No. (Figure 5-11, (1))	
4TNE92	129150-35152
4TNE94L	
4TNE98	

4. Add new engine oil to the engine as specified in *Adding Engine Oil on page 4-14*.

### Check and Adjust the Governor Lever and Engine Speed Control

The governor lever and engine speed control (accelerator lever, pedal, etc.) of the machine are connected together by an accelerator cable or rod. If the cable becomes stretched, or the connections loosen, the governor lever may not respond to change of engine speed control position. This may make operation of the machine unsafe. Check the cable periodically and adjust if necessary. Consult your authorized Yanmar industrial engine dealer or distributor for the adjustment procedure.

NEVER force the accelerator cable or pedal to move. This may deform the governor lever or stretch the cable and cause irregular operation of the engine speed control.

Checking and adjusting the governor lever:

1. Check that the governor lever (**Figure 5-12, (1)**) makes uniform contact with the low idle (**Figure 5-12, (2)**) and high idle (**Figure 5-12, (3)**) speed limit screws when the engine speed control is in the high idle speed or low idle speed position.
2. If the governor lever does not make contact with the high idle or low idle speed limit screw, adjust the accelerator cable.
3. In some engine speed control applications, loosen the accelerator cable locknut and adjust the cable so the governor lever makes proper contact with the high / low idle speed limit screw.

### NOTICE

NEVER attempt to adjust the low or high idle speed limit screw. This may impair the safety and performance of the machine and shorten its life. If the idle speed limit screws require adjustment, see your authorized Yanmar industrial engine dealer or distributor.

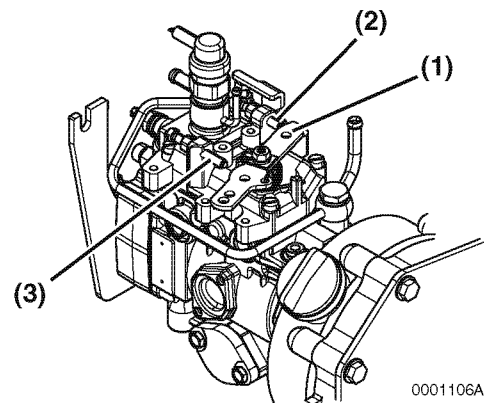

Figure 5-12

### Every 1000 Hours of Operation

Perform the following maintenance every 1000 hours of operation.

- Adjust Intake / Exhaust Valve Clearance
- Clean Fuel / Water Separator
- Replace Fuel Filter

#### Adjust Intake / Exhaust Valve Clearance

Proper adjustment is necessary to maintain the correct timing for opening and closing the valves. Improper adjustment will cause the engine to run noisily, resulting in poor engine performance and engine damage. *See Measuring and Adjusting Valve Clearance on page 6-30.*

#### Clean Fuel Filter / Water Separator

##### DANGER

##### FIRE AND EXPLOSION HAZARD!



• Diesel fuel is extremely flammable and explosive under certain conditions.

- When you remove any fuel system component to perform maintenance (such as changing the fuel filter) place an approved container under the opening to catch the fuel.
- NEVER use a shop rag to catch the fuel. Vapors from the rag are extremely flammable and explosive.
- Wipe up any spills immediately.
- Wear eye protection. The fuel system is under pressure and fuel could spray out when you remove any fuel system component.
- Failure to comply will result in death or serious injury.

### NOTICE

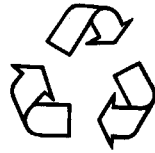

Be responsible to the environment. Follow these procedures for hazardous waste disposal. Failure to follow these procedures may seriously harm the environment.

- Follow the guidelines of the EPA or other governmental agency for the proper disposal of hazardous materials such as engine oil, diesel fuel and engine coolant. Consult the local authorities or reclamation facility.
- NEVER dispose of hazardous materials irresponsibly by dumping them into a sewer, on the ground or into ground water or waterways.

Periodically clean the fuel filter / water separator element and inside cup.

1. Position an approved container under the cup (**Figure 5-13, (1)**) of the fuel filter / water separator to collect the contaminants.
2. Close (**Figure 5-13, (2)**) the fuel cock (**Figure 5-13, (3)**).
3. Loosen the drain cock (**Figure 5-13, (4)**) and drain the contaminants. *See Drain Fuel Filter / Water Separator on page 5-6.*
4. Turn the retaining ring (**Figure 5-13, (5)**) to the left (**Figure 5-13, (10)**) and remove the cup (**Figure 5-13, (6)**). If equipped, disconnect the sensor wire (**Figure 5-13, (7)**) from the cup before removing the cup.
5. Carefully hold the cup to prevent fuel from spilling. If you spill any fuel, clean up the spill completely.

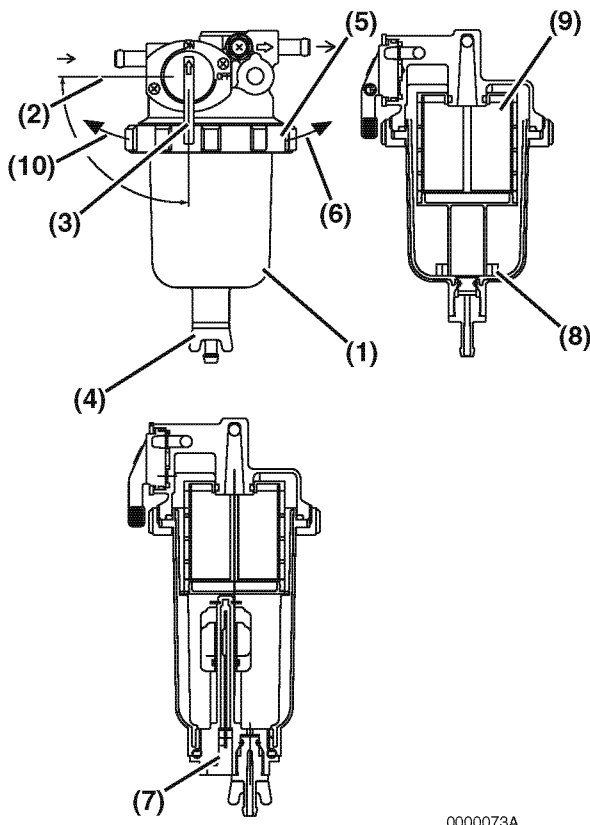

0000073A

Figure 5-13

6. Remove the float ring (Figure 5-13, (8)) from the cup. Pour the contaminants into the container and dispose it properly.
7. Clean the element (Figure 5-13, (9)) and inside cup. Replace the element if it is damaged.

Applicable Element Part No.(Figure 5-13, (9))	
4TNE92	119802-55710
4TNE94L	
4TNE98	

8. Install the element and O-ring in the bracket.
9. Position the float ring in the cup.
10. Check the O-ring on the cup. Replace if necessary.
11. Install the cup to the bracket by tightening the retaining ring to the right (Figure 5-13, (6)) to a torque of 11-15 ft lbs (15-20 N•m, 1.5-2.0 kgf•m).

12. Close the drain cock. Reconnect the sensor wire if equipped.
13. Open the fuel cock (Figure 5-13, (3)).
14. Prime the fuel system. See *Priming the Fuel System* on page 4-11.
15. Check for leaks.

**Replace Fuel Filter**

**⚠ DANGER**

**FIRE AND EXPLOSION HAZARD!**



•Diesel fuel is extremely flammable and explosive under certain conditions.

- When you remove any fuel system component to perform maintenance (such as changing the fuel filter) place an approved container under the opening to catch the fuel.
- NEVER use a shop rag to catch the fuel. Vapors from the rag are extremely flammable and explosive.
- Wipe up any spills immediately.
- Wear eye protection. The fuel system is under pressure and fuel could spray out when you remove any fuel system component.
- Failure to comply will result in death or serious injury.

## ⚠ WARNING

### HIGH PRESSURE HAZARD!



- Avoid skin contact with high pressure diesel fuel spray caused by a fuel system leak such as a broken fuel injection line. High pressure fuel can penetrate your skin and result in serious injury. If you are exposed to high pressure fuel spray obtain prompt medical treatment.
- NEVER check for a fuel leak with your hands. ALWAYS use a piece of wood or cardboard. Have your authorized Yanmar industrial engine dealer or distributor repair the damage.
- Failure to comply could result in death or serious injury.

## NOTICE

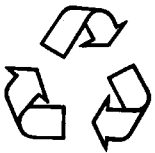

Be responsible to the environment. Follow these procedures for hazardous waste disposal. Failure to follow these procedures may seriously harm the environment.

- Follow the guidelines of the EPA or other governmental agency for the proper disposal of hazardous materials such as engine oil, diesel fuel and engine coolant. Consult the local authorities or reclamation facility.
- NEVER dispose of hazardous materials irresponsibly by dumping them into a sewer, on the ground or into ground water or waterways.

## NOTICE

For maximum engine life, Yanmar recommends that when shutting the engine down, you allow the engine to idle, without load, for 5 minutes. This will allow the engine components that operate at high temperatures, such as the turbocharger (if equipped) and exhaust system, to cool slightly before the engine itself is shut down.

Replace the fuel filter at specified intervals to prevent contaminants from adversely affecting the diesel fuel flow.

1. Stop the engine and allow it to cool.
2. Close all fuel cocks in fuel line.
3. Disconnect the fuel filter sensor connector (**Figure 5-14, (1)**).

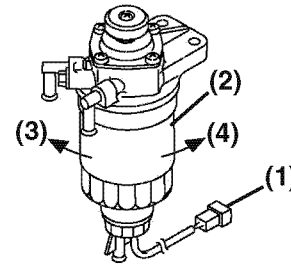

0000862D

**Figure 5-14**

4. Place an approved container under fuel filter.
5. Carefully open the drain plug (**Figure 5-15, (1)**) to drain fuel from the fuel filter.
6. Remove the fuel filter (**Figure 5-14, (2)**) by turning it to the left (**Figure 5-14, (3)**). Wipe up all spilled fuel.
7. Remove the drain plug (**Figure 5-15, (1)**) from the fuel filter (**Figure 5-15, (2)**) by turning it to the left (**Figure 5-15, (3)**).
8. Check the condition of the drain plug O-ring (**Figure 5-15, (4)**). Replace the O-ring if damaged.



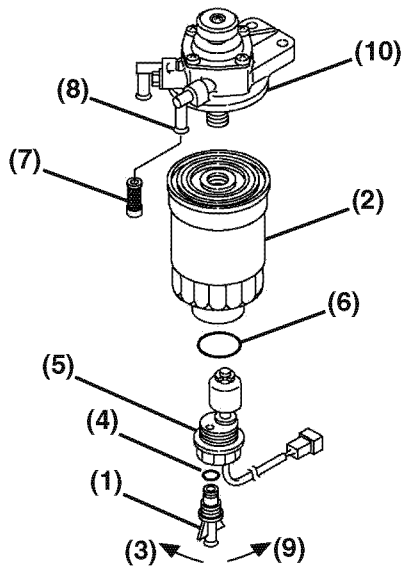

0000863B

Figure 5-15

9. Set the drain plug aside for reinstallation.
10. Remove the fuel filter sensor assembly (Figure 5-15, (5)) by turning it to the left (Figure 5-15, (3)).
11. Carefully remove the in-line fuel filter (Figure 5-15, (7)) from the output nipple (Figure 5-15, (8)) that goes to the fuel injection pump.
12. Dispose of the fuel, fuel filters and O-ring (if replaced) properly. Follow the guidelines of the EPA or other government agency.
13. Carefully install the new in-line fuel filter (Figure 5-15, (7)) into the output nipple (Figure 5-15, (8)).
14. Carefully install the fuel filter sensor assembly (Figure 5-15, (5)) in the new fuel filter (Figure 5-15, (3)) by turning the fuel filter sensor assembly to the right (Figure 5-15, (9)).
15. Install the drain plug (Figure 5-15, (1)) on the new fuel filter (Figure 5-15, (3)) by turning the drain plug to the right (Figure 5-15, (8)). Hand tighten only.

16. Clean the fuel filter mounting surface (Figure 5-15, (10)) and apply a small amount of diesel fuel to the gasket of the new filter.
17. Install the new fuel filter (Figure 5-14, (2)) by turning it to the right (Figure 5-14, (4)) until it contacts the mounting surface. Tighten one additional turn.
18. Open all fuel cocks in the fuel line.
19. Reconnect the fuel filter sensor connector (Figure 5-14, (1)).
20. Prime the fuel system. See *Priming the Fuel System* on page 4-11.
21. Check for fuel leaks.

Applicable Fuel Filter Part No. (Figure 5-14, (2))	
4TNE92	129901-55850
4TNE94L	
4TNE98	

Applicable In-Line Fuel Filter Part No. (Figure 5-15, (7))	
4TNE92	129901-55860
4TNE94L	
4TNE98	

## PERIODIC MAINTENANCE

### Every 2000 Hours of Operation

Perform the following maintenance every 2000 hours of operation.

- Replace Air Cleaner Element
- Inspect Clean and Test Fuel Injectors, if necessary

#### Replace Air Cleaner Element

#### NOTICE

The maximum air intake restriction shall be 0.90 psi (6.23 kPa; 635 mm Aq) or less. Clean or replace the air cleaner element if the air intake restriction exceeds the above mentioned value.

Replace the air cleaner element (**Figure 5-7, (2)**) every 2000 hours even if it is not damaged or dirty.

When replacing the element, clean the inside of the air cleaner case (**Figure 5-7, (4)**).

If the air cleaner is equipped with a double element, *only remove and replace the inner element (Figure 5-8, (1)) if the engine lacks power or the dust indicator actuates (if equipped)*. This is in addition to replacing the outer element.

### Inspect Clean and Test Fuel Injectors

#### ⚠ WARNING

#### HIGH PRESSURE HAZARD!



- Avoid skin contact with high pressure diesel fuel spray caused by a fuel system leak such as a broken fuel injection line. High pressure fuel can penetrate your skin and result in serious injury. If you are exposed to high pressure fuel spray obtain prompt medical treatment.
- **NEVER** check for a fuel leak with your hands. **ALWAYS** use a piece of wood or cardboard. Have your authorized Yanmar industrial engine dealer or distributor repair the damage.
- Failure to comply could result in death or serious injury.

Proper operation of the fuel injectors is required to obtain the optimum injection pattern for full engine performance. The EPA / ARB requires that you have the injectors inspected, cleaned and tested every 2000 hours. See *Servicing the Fuel Injectors* on page 7-35.

**Every 4000 Hours of Operation**

- Drain, Flush, and Re-fill the Coolant System with New Coolant
- Replace Fuel Hoses and Engine Coolant Hoses

**Drain, Flush, and Re-fill the Coolant System with New Coolant**

**⚠ DANGER**

**SCALD HAZARD!**



- NEVER remove the radiator cap if the engine is hot. Steam and hot engine coolant will spurt out and seriously burn you. Allow the engine to cool down before you attempt to remove the radiator cap.

- Securely tighten the radiator cap after you check the radiator. Steam can spurt out during engine operation if the cap is loose.
- ALWAYS check the level of engine coolant by observing the reserve tank.
- Failure to comply will result in death or serious injury.

**⚠ CAUTION**

**COOLANT HAZARD!**



- Wear eye protection and rubber gloves when you handle Long Life or Extended Life engine coolant. If contact with the eyes or skin should occur, wash with clean water.

- Failure to comply may result in minor or moderate injury.

**NOTICE**

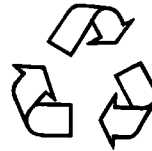

Be responsible to the environment. Follow these procedures for hazardous waste disposal. Failure to follow these procedures may seriously harm the environment.

- Follow the guidelines of the EPA or other governmental agency for the proper disposal of hazardous materials such as engine oil, diesel fuel and engine coolant. Consult the local authorities or reclamation facility.
- NEVER dispose of hazardous materials irresponsibly by dumping them into a sewer, on the ground or into ground water or waterways.

Engine coolant contaminated with rust or scale reduces the cooling effect. Even when extended life engine coolant is properly mixed, the engine coolant gets contaminated as its ingredients deteriorate. Drain, flush and re-fill the cooling system with new coolant every 4000 hours or once every 2 years, whichever comes first.

1. Remove the radiator cap (**Figure 5-16, (1)**).
2. Remove the drain plug or open the drain cock (**Figure 5-16, (2)**) at the lower portion of the radiator and drain the engine coolant.

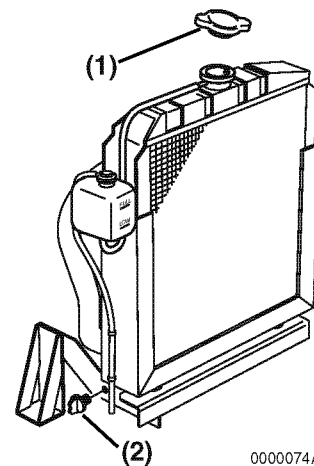

0000074A

**Figure 5-16**

## PERIODIC MAINTENANCE

---

3. Remove the coolant drain plug (Figure 5-17, (1)) from the engine block.

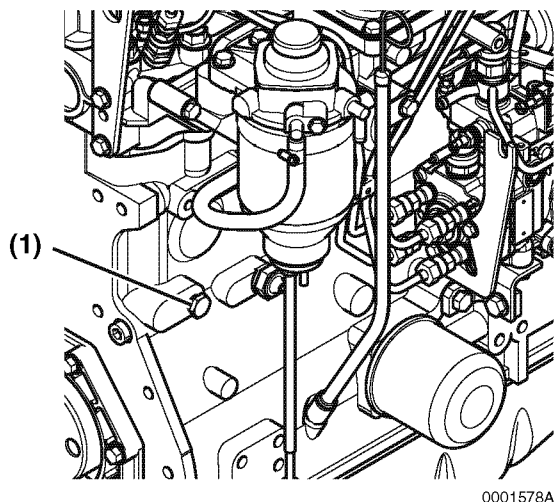

**Figure 5-17**

4. After draining the engine coolant, flush the radiator and engine block to remove any rust, scale and contaminants. Then reinstall and tighten the drain plug or close the drain cock in the radiator. Reinstall and tighten the engine block drain plug.
5. Fill radiator and engine with engine coolant.  
*See Filling Radiator With Engine Coolant on page. 4-16.*

### **Replace Fuel Hoses and Engine Coolant Hoses**

Replace the fuel and engine coolant hoses at least every two years.

## Section 6

# ENGINE

---

## Table of Contents

	Page
Engine Service Information .....	6-3
Engine Body .....	6-3
Gear Train and Camshaft .....	6-5
Engine Special Torque Chart .....	6-10
Special Service Tools .....	6-11
Measuring instruments .....	6-13
Before You Begin Servicing .....	6-16
Removal of Engine .....	6-17
Cylinder Head Components .....	6-18
Disassembly of Cylinder Head .....	6-19
Cleaning of Cylinder Head Components .....	6-23
Inspection of Cylinder Head Components .....	6-23
Assembly of Cylinder Head .....	6-26
Measuring and Adjusting Valve Clearance .....	6-30
Valve Clearance Measurement .....	6-30
Valve Clearance Adjustment .....	6-31
Drive Train and Camshaft Components .....	6-32
Disassembly of Drive Train and Camshaft Components .....	6-33
Inspection of Drive Train and Camshaft Components .....	6-38
Honing and Boring .....	6-45
Assembly of Drive Train and Camshaft Components .....	6-46

**This Page Intentionally Left Blank**

This section of the *Service Manual* describes the servicing of the engine.

## ENGINE SERVICE INFORMATION

### Engine Body

#### Cylinder Head

Inspection Item		Standard	Limit	Reference Page
Combustion Surface Distortion (Flatness)		0.0020 in (0.05 mm) or less	0.0059 in (0.15 mm)	See <i>Inspection of Cylinder Head</i> on page 6-24
Valve Sink	Intake	0.020 - 0.028 in (0.5 - 0.7 mm)	0.039 in (1.0 mm)	See <i>Inspection of Intake and Exhaust Valves</i> on page 6-24
	Exhaust	0.024 - 0.032 in (0.6 - 0.8 mm)	0.043 in (1.1 mm)	
Valve Seat Angle	Intake	120°	-	
	Exhaust	90°	-	

#### Intake / Exhaust Valve and Guide

Inspection item		Standard	Limit	Reference Page
Intake Valve	Guide Inside Diameter	0.3156 - 0.3161 in (8.015 - 8.030 mm)	0.3189 in (8.10 mm)	See <i>Inspection of Intake and Exhaust Valves</i> on page 6-24
	Valve Stem Outside Diameter	0.3136 - 0.3142 in (7.965 - 7.980 mm)	0.3110 in (7.90 mm)	
	Oil Clearance	0.0014 - 0.0026 in (0.035 - 0.065 mm)	0.0071 in (0.18 mm)	
Exhaust Valve	Guide Inside Diameter	0.3156 - 0.3161 in (8.015 - 8.030 mm)	0.3189 in (8.10 mm)	
	Valve Stem Outside Diameter	0.3136 - 0.3138 in (7.965 - 7.970 mm)	0.3110 in (7.90 mm)	
	Oil Clearance	0.0018 - 0.0030 in (0.045 - 0.075 mm)	0.0071 in (0.18 mm)	
Valve Guide Projection From Cylinder Head		0.58 - 0.60 in (14.7 - 15.0 mm)	-	See <i>Assembly of Valve Guides</i> on page 6-26
Valve Seal Projection from Cylinder head		0.66 - 0.70 in (16.7 - 17.0 mm)	-	See <i>Assembly of Valve Guides</i> on page 6-26

# ENGINE

## Valve Spring

Inspection Item	Standard	Limit	Reference Page
Free Length	1.87 in (47.5 mm)	-	<i>See Inspection of Valve Springs on page 6-26</i>
Squareness	-	0.05 in (1.2 mm)	

## Rocker Arm and Shaft

Inspection Item	Standard	Limit	Reference Page
Arm Shaft Inside Diameter	0.7283 - 0.7291 in (18.50 - 18.52 mm)	0.7311 in (18.57 mm)	<i>See Inspection of Rocker Arm Assembly on page 6-23</i>
Shaft Outside Diameter	0.7272 - 0.7280 in (18.47 - 18.49 mm)	0.7252 in (18.42 mm)	
Oil Clearance	0.0004 - 0.0020 in (0.01 - 0.05 mm)	0.0059 in (0.15 mm)	

## Push Rod

Inspection Item	Standard	Limit	Reference Page
Push Rod Straightness	-	0.0012 in (0.03 mm)	<i>See Inspection of Push Rods on page 6-23</i>



## Gear Train and Camshaft

### Camshaft

Inspection Item		Standard	Limit	Reference Page	
Side Gap		0.0020 - 0.0079 in (0.05 - 0.20 mm)	0.0118 in (0.30 mm)	<i>See Removal of Camshaft on page 6-37</i>	
Bending (1/2 the Dial Gauge Reading)		0 - 0.0008 in (0 - 0.02 mm)	0.0020 in (0.05 mm)	<i>See Inspection of Camshaft on page 6-43</i>	
Cam Height		1.6707 - 1.6758 in (42.435 - 42.565 mm)	1.6608 in (42.185 mm)		
Camshaft Oil Clearance	Gear End	Bushing Inside Diameter	1.9681 - 1.9707 in (49.990 - 50.055 mm)		1.9736 in (50.130 mm)
		Camshaft Outside Diameter	1.9656 - 1.9665 in (49.925 - 49.950 mm)		1.9642 in (49.890 mm)
		Oil Clearance	0.0016 - 0.0051 in (0.04 - 0.130 mm)		0.0094 in (0.240 mm)
	Intermediate	Bushing Inside Diameter	1.9685 - 1.9695 in (50.000 - 50.025 mm)		1.9724 in (50.100 mm)
		Camshaft Outside Diameter	1.9650 - 1.9659 in (49.910 - 49.935 mm)		1.9636 in (49.875 mm)
		Oil Clearance	0.0026 - 0.0045 in (0.065 - 0.115 mm)		0.0089 in (0.225 mm)
	Flywheel End	Bushing Inside Diameter	1.9685 - 1.9695 in (50.000 - 50.025 mm)		1.9724 in (50.100 mm)
		Camshaft Outside Diameter	1.9656 - 1.9665 in (49.925 - 49.950 mm)		1.9642 in (49.890 mm)
		Oil Clearance	0.0020 - 0.0039 in (0.050 - 0.100 mm)	0.0083 in (0.210 mm)	

### Idler Gear Shaft and Bushing

Inspection Item	Standard	Limit	Reference Page
Shaft Outside Diameter	1.8091 - 1.9675 in (45.950 - 49.975 mm)	1.8071 in (45.900 mm)	<i>See Inspection of Idler Gear and Shaft on page 6-44</i>
Bushing Inside Diameter	1.8110 - 1.8120 in (46.000 - 46.025 mm)	1.8140 in (46.075 mm)	
Clearance	0.0010 - 0.0030 in (0.025 - 0.075 mm)	0.0069 in (0.175 mm)	

# ENGINE

## Backlash of Each Gear

Inspection Item	Standard	Limit	Reference Page
Crankshaft Gear, Camshaft Gear, Idler Gear, Fuel Injection Pump Gear	0.0031 - 0.0055 in (0.08 - 0.14 mm)	0.0063 in (0.16 mm)	-
Lubricating Oil Pump Gear	0.0035 - 0.0059 in (0.09 - 0.15 mm)	0.0067 in (0.17 mm)	-

## Cylinder Block

Inspection Item	Standard	Limit	Reference Page
Cylinder Inside Diameter	4TNE92	3.6220 - 3.6232 in (92.000 - 92.030 mm)	3.6272 in (92.130 mm)
	4TNE94	3.7008 - 3.7020 in (94.000 - 94.030 mm)	3.7059 in (94.130 mm)
	4TNE98	3.8583 - 3.8594 in (98.000 - 98.030 mm)	3.8634 in (98.130 mm)
Cylinder Bore	Roundness	0.0004 in (0.01 mm) or less	0.0012 in (0.03 mm)
	Inclination		

*See Inspection of Cylinder Block on page 6-38*

## Crankshaft

Inspection Item	Standard	Limit	Reference Page	
Bending (1/2 the dial gauge reading)	-	0.0008 in (0.02 mm)	<i>See Inspection of Crankshaft on page 6-42</i>	
Connecting Rod Journals	Pin Outside Diameter	2.2816 - 2.2820 in (57.952 - 57.962 mm)		2.2796 in (57.902 mm)
	Bearing Halves Inside Diameter	2.2835 - 2.2845 in (58.000 - 58.026 mm)		-
	Bearing Halves Thickness	0.0587 - 0.0591 in (1.492 - 1.500 mm)		-
	Oil Clearance	0.0015 - 0.0029 in (0.038 - 0.074 mm)		0.0059 in (0.150 mm)
Crank Journal Selective Pairing	Journal Outside Diameter	2.5572 - 2.5576 in (64.952 - 64.962 mm)		2.5552 in (64.902 mm)
	Bearing Halves Inside Diameter	2.5591 - 2.5598 in (65.000 - 65.020 mm)		-
	Bearing Halves Thickness	0.0785 - 0.0791 in (1.995 - 2.010 mm)		-
	Oil Clearance	0.0015 - 0.0027 in (0.038 - 0.068 mm)		0.0059 in (0.150 mm)

**Thrust Bearing**

Inspection Item	Standard	Limit	Reference Page
Crankshaft Side Gap	0.0043 - 0.0083 in (0.11 - 0.21 mm)	0.0110 in (0.28 mm)	See <i>Removal of Crankshaft</i> on page 6-36

**Piston**

Inspection Item	Standard	Limit	Reference Page
Piston Outside Diameter (Measure in the Direction Vertical to the Piston Pin.)	4TNE92	3.6199 - 3.6211 in (91.945 - 91.975 mm)	3.6181 in (91.900 mm)
	4TNE94L	3.6986 - 3.6990 in (93.945 - 93.955 mm)	3.6969 in (93.900 mm)
	4TNE98	3.8559 - 3.8563 in (97.940 - 97.950 mm)	3.8543 in (97.900 mm)
Piston Diameter Measure Position (Upward From the Bottom End of the Piston.)		0.8661 in (22.000 mm)	-
Piston Pin	Hole Inside Diameter	1.1811 - 1.1815 in (30.000 - 30.009 mm)	1.1826 in (30.039 mm)
	Pin Outside Diameter	1.1807 - 1.1811 in (29.989 - 30.000 mm)	1.1795 in (29.959 mm)
	Clearance	0.0000 - 0.0008 in (0.000 - 0.020 mm)	0.0032 in (0.080 mm)

# ENGINE

## Piston Ring

Inspection Item		Standard	Limit	Reference Page
Top Ring	Ring Groove Width	0.0803 - 0.0811 in (2.040 - 2.060 mm)	-	<i>See Inspection of Pistons on page 6-41</i>
	Ring Width	0.0764 - 0.0772 in (1.940 - 1.960 mm)	0.0756 in (1.920 mm)	
	Side Clearance	0.0032 - 0.0047 in (0.080 - 0.120 mm)	-	
	End Clearance	0.0098 - 0.0177 in (0.250 - 0.450 mm)	0.0213 in (0.540 mm)	
Second Ring	Ring Groove Width	0.0819 - 0.0825 in (2.080 - 2.095 mm)	0.0864 in (2.195 mm)	
	Ring Width	0.0776 - 0.0783 in (1.970 - 1.990 mm)	0.0768 in (1.950 mm)	
	Side Clearance	0.0035 - 0.0049 in (0.090 - 0.125 mm)	0.0096 in (0.245 mm)	
	End Clearance	0.0177 - 0.0256 in (0.450 - 0.650 mm)	0.0287 in (0.730 mm)	
Oil Ring	Ring Groove Width	0.1187 - 0.1193 in (3.015 - 3.030 mm)	0.1232 in (3.130 mm)	
	Ring Width	0.1169 - 0.1177 in (2.970 - 2.990 mm)	0.1161 in (2.950 mm)	
	Side Clearance	0.0010 - 0.0024 in (0.025 - 0.060 mm)	0.0071 in (0.180 mm)	
	End Clearance	0.0100 - 0.0177 in (0.250 - 0.450 mm)	0.0217 in (0.550 mm)	

## Connecting Rod

Inspection Item	Standard	Limit	Reference Page
Thrust Clearance	0.0051 - 0.0091 in (0.13 - 0.23 mm)	-	<i>See Inspection of Connecting Rod on page 6-42</i>

## Rod Small End

Inspection Item	Standard	Limit	Reference Page
Bushing Inside Diameter	1.1821 - 1.1826 in (30.025 - 30.038 mm)	1.1838 in (30.068 mm)	<i>See Inspection of Connecting Rod on page 6-42</i>
Pin Outside Diameter	1.1806 - 1.1811 in (29.987 - 30.000 mm)	1.1795 in (29.959 mm)	
Clearance	0.0010 - 0.0020 in (0.025 - 0.051 mm)	0.0043 in (0.109 mm)	

**Tappet**

Inspection Item	Standard	Limit	Reference Page
Cylinder Block Tappet Hole Inside Diameter	0.4724 - 0.4732 in (12.000 - 12.018 mm)	0.4739 in (12.038 mm)	<i>See Inspection of Tappets on page 6-42</i>
Tappet Stem Outside Diameter	0.4715 - 0.4720 in (11.975 - 11.990 mm)	0.4707 in (11.955 mm)	
Oil Clearance	0.0004 - 0.0017 in (0.010 - 0.043 mm)	0.0033 in (0.083 mm)	

## ENGINE

### ENGINE SPECIAL TORQUE CHART

Component	Thread Diameter and Pitch	Tightening Torque	Lubricating Oil Application (Thread Portion and Seat Surface)	Reference Page
Cylinder Head Bolts	M11 x 1.25 mm	76.0 - 83.3 ft lbs (103.1 - 112.9 N·m, 10.5 - 11.5kgf·m)	Applied	<i>See Assembly of Cylinder Head on page 6-28</i>
Connecting Rod Bolts	M10 x 1.0 mm	39.8 - 43.4 ft lbs (53.9 - 58.8 N·m, 5.5 - 6.0 kgf·m)	Applied	<i>See Installation of Pistons on page 6-48</i>
Flywheel Bolts	M14 x 1.5 mm	137.3 - 151.8 ft lbs (186.2 - 205.8 N·m, 19.0 - 21.0 kgf·m)	Applied	<i>See Installation of Crankshaft on page 6-47</i>
Main Bearing Cap Bolts	M11 x 1.25 mm	79.7 - 87.0 ft lbs (108.1 - 117.9N·m, 11.0 - 12.0 kgf·m)	Applied	<i>See Installation of Crankshaft on page 6-47</i>
Crankshaft Pulley Bolts	M14 x 1.5 mm	79.6 - 87.0 ft lbs (107.9 - 127.5 N·m, 11.0 - 13.0 kgf·m)	Applied	<i>See Installation of Crankshaft on page 6-47</i>

# SPECIAL SERVICE TOOLS

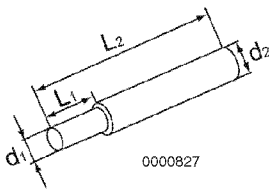
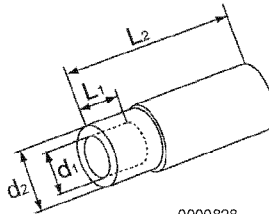
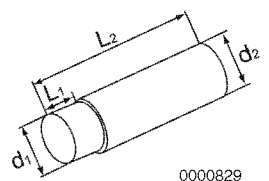
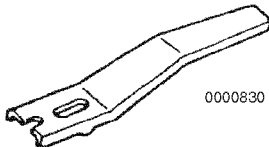
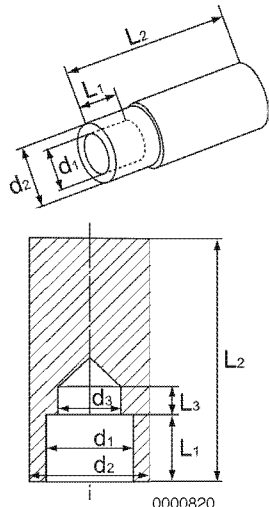
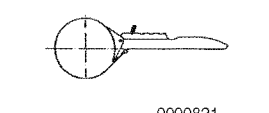
No	Tool Name	Applicable model and tool size				Illustration		
		L1	L2	d1	d2			
1	Valve Guide Tool (For Removing Valve Guides)	L1	L2	d1	d2	 <p>0000827</p>		
		0.787 in (20 mm)	2.953 in (75 mm)	0.295 in (7.5 mm)	0.433 in (11 mm)			
		Locally Manufactured						
2	Valve Guide Tool (For Installing Valve Guides)	L1	L2	d1	d2	 <p>0000828</p>		
		0.591 in (15 mm)	2.559 in (65 mm)	0.551 in (14 mm)	0.787 in (20 mm)			
		Locally Manufactured						
3	Wrist Pin Bushing Tool (For Removing/ Installing of Wrist Pin Bushings)	L1	L2	d1	d2	 <p>0000829</p>		
		0.787 in (20 mm)	3.937 in (100 mm)	1.181 in (30 mm)	1.299 in (33 mm)			
		Locally Manufactured						
4	Valve Spring Compressor (For Removing/ Installing Valve Springs)	Yanmar Part No. 129100-92630				 <p>0000830</p>		
5	Stem Seal Tool (for Installing Stem Seals)	d1	d2	d3	L1	L2	L3	 <p>0000820</p>
		0.638 in (16.2 mm)	0.866 in (22 mm)	0.531 in (13.5 mm)	0.669 in (17.0 mm)	2.560 in (65 mm)	0.157 in (4 mm)	
		Locally Manufactured						
6	Filter Wrench (For Removing / Installing Engine Oil Filter)	Available Locally				 <p>0000821</p>		

# ENGINE

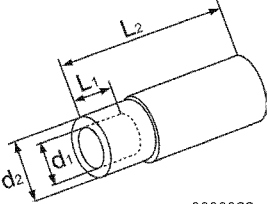
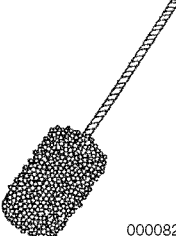
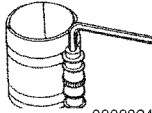
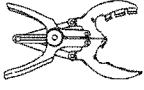
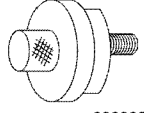
No	Tool Name	Applicable model and tool size	Illustration									
7	Camshaft Bushing Tool (For Removing Camshaft Bushing)	<table border="1" data-bbox="368 203 1141 315"> <thead> <tr> <th>L1</th> <th>L2</th> <th>d1</th> <th>d2</th> </tr> </thead> <tbody> <tr> <td>0.709 in (18 mm)</td> <td>2.756 in (70 mm)</td> <td>1.969 in (50 mm)</td> <td>2.087 in (53 mm)</td> </tr> </tbody> </table> <p data-bbox="368 315 1141 383">Allowance: <math>d1 \begin{smallmatrix} -0.3 \\ -0.6 \end{smallmatrix}</math> <math>d2 \begin{smallmatrix} -0.3 \\ -0.6 \end{smallmatrix}</math> Locally Manufactured</p>	L1	L2	d1	d2	0.709 in (18 mm)	2.756 in (70 mm)	1.969 in (50 mm)	2.087 in (53 mm)	 <p data-bbox="1348 414 1412 436">0000822</p>	
L1	L2	d1	d2									
0.709 in (18 mm)	2.756 in (70 mm)	1.969 in (50 mm)	2.087 in (53 mm)									
8	Flex-Hone (For Preparing Cylinder Walls)	<table border="1" data-bbox="368 465 1141 616"> <thead> <tr> <th>Model</th> <th>Part Number</th> <th>Cylinder Bore</th> </tr> </thead> <tbody> <tr> <td>4TNE92 4TNE94</td> <td>129400-92430</td> <td>83 - 95 mm</td> </tr> <tr> <td>4TNE98</td> <td>129400-92440</td> <td>89 - 101 mm</td> </tr> </tbody> </table>	Model	Part Number	Cylinder Bore	4TNE92 4TNE94	129400-92430	83 - 95 mm	4TNE98	129400-92440	89 - 101 mm	 <p data-bbox="1332 694 1396 716">0000823</p>
Model	Part Number	Cylinder Bore										
4TNE92 4TNE94	129400-92430	83 - 95 mm										
4TNE98	129400-92440	89 - 101 mm										
9	Piston Ring Compressor (For Installing Pistons)	<p data-bbox="494 757 1013 846">Yanmar Part No. 95550-002476 The Piston Insertion Tool is Applicable for 2.362 - 4.921 in (60 - 125 mm) Diameter Pistons</p>	 <p data-bbox="1300 851 1364 873">0000824</p>									
10	Piston Ring Tool (For Removing/Installing of Piston Rings)	<p data-bbox="662 947 845 969">Available Locally</p>	 <p data-bbox="1300 1008 1364 1030">0000825</p>									
11	Crankshaft Pulley Tool (For Installing Crankshaft Pulley)	<p data-bbox="638 1104 869 1160">Locally Manufactured (for 4TNV94L)</p>	 <p data-bbox="1308 1198 1372 1220">0000826</p>									

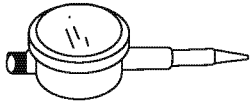
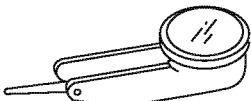
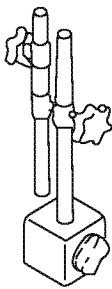
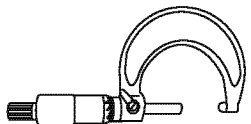
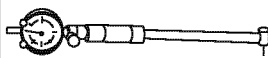
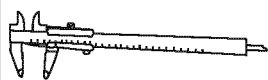
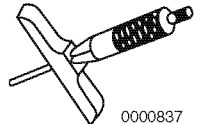
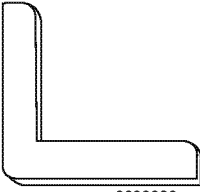

## MEASURING INSTRUMENTS

No.	Instrument Name	Application	Illustration
1	Dial Gauge	Measurements of shaft bending, and strain and gap of surfaces	 0000831
2	Test Indicator	Measurements of narrow or deep portions that cannot be measured by dial gauge	 0000832
3	Magnetic Stand	For holding the dial gauge when measuring.	 0000833
4	Micrometer	For measuring the outside diameters of crankshaft, pistons, piston pins, etc.	 0000834
5	Cylinder Gauge	For measuring the inside diameters of cylinder liners, rod metal, etc.	 0000835
6	Calipers	For measuring outside diameters, depth, thickness and width	 0000836
7	Depth Micrometer	For measuring of valve sink	 0000837
8	Square	For measuring valve spring inclination and straightness of parts	 0000838

# ENGINE

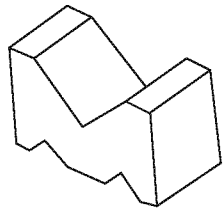
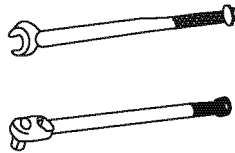
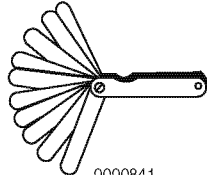
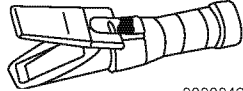
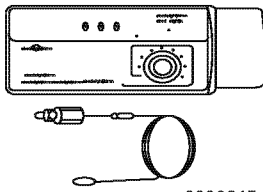
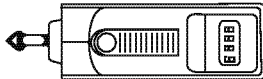
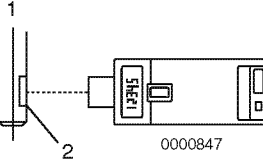
No.	Instrument Name		Application	Illustration
9	V-Block		For measuring shaft bend	 <p>0000839</p>
10	Torque Wrench		For tightening nuts and bolts to the specified torque	 <p>0000840</p>
11	Feeler Gauge		For measuring gaps between ring and ring groove, and shaft joints during assembly	 <p>0000841</p>
12	Battery Coolant Tester		For checking concentration of antifreeze and the battery electrolyte charge status	 <p>0000843</p>
13	Digital Thermometer		For measuring temperatures	 <p>0000845</p>
14	Tachometer	Contact Type	For measuring revolution by contacting the revolving shaft	 <p>0000846</p>
	Tachometer	Photoelectric Type	For measuring revolution by sensing the reflecting mark on the outer periphery of the revolving shaft	 <p>0000847</p>
	Tachometer	Fuel High Pressure Pipe Clamp Type	This measures the revolution regardless of the center or periphery of the revolving object	

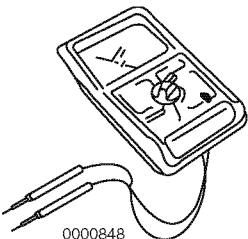
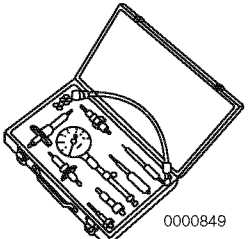
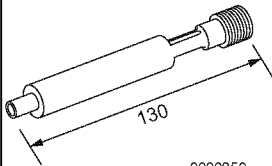
No.	Instrument Name	Application	Illustration
15	Circuit Tester	For measuring resistance, voltage and continuity of electrical circuits	 <p>0000848</p>
16	Compression Gauge Kit	For measuring compression pressure Gauge Set Part No. TOL-97190080	 <p>0000849</p>
	New Compression Test Adaptor	Adapter for direct injection 2-valve cylinder head Adapter Part No. 119802-92950	 <p>0000850</p>

# ENGINE

## Before You Begin Servicing

### WARNING

#### SEVER HAZARD!



- Stop the engine before you begin to service it.

- NEVER leave the key in the key switch when you are servicing the engine. Someone may accidentally start the engine and not realize you are servicing it. This could result in a serious injury.
- If you must service the engine while it is operating, remove all jewelry, tie back long hair, and keep your hands, other body parts and clothing away from moving / rotating parts.
- Failure to comply could result in death or serious injury.

### WARNING

#### EXPOSURE HAZARD!

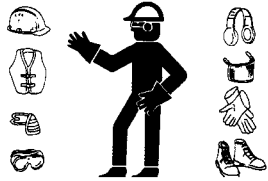

- Always read and follow safety related precautions found on containers of hazardous substances like parts cleaners, primers, sealants, and sealant removers.

- Failure to comply could result in death or serious injury.

### CAUTION

#### FLYING OBJECT HAZARD!



- ALWAYS wear eye protection when servicing engine and when using compressed air or high-pressure water. Dust, flying debris, compressed air, pressurized water or steam may injure your eyes.
- Failure to comply may result in minor or moderate injury.

### NOTICE

- Only use the engine oil specified. Other engine oils may affect warranty coverage, cause internal engine components to seize, or shorten engine life.
- Prevent dirt and debris from contaminating engine oil. Carefully clean the oil cap / dipstick and the surrounding area before you remove the cap.
- NEVER mix different types of engine oil. This may adversely affect the lubricating properties of the engine oil.
- NEVER overfill. Overfilling may result in white exhaust smoke, engine overspeed or internal damage.
- Only use the engine coolant specified. Other engine coolants may affect warranty coverage, cause an internal build up of rust and scale and / or shorten engine life.
- Prevent dirt and debris from contaminating engine coolant. Carefully clean the radiator cap and the surrounding area before you remove the cap.
- NEVER mix different types of engine coolants. This may adversely affect the properties of the engine coolant.

## REMOVAL OF ENGINE

1. Disconnect the battery cables at the battery.

### WARNING

#### SHOCK HAZARD!



- Turn off the battery switch (if equipped) or disconnect the negative battery cable before servicing the electrical system.
  - Check the electrical harnesses for cracks, abrasions, and damaged or corroded connectors. **ALWAYS** keep the connectors and terminals clean.
  - Failure to comply could result in death or serious injury.
- 
2. Disconnect the throttle cable and vehicle electrical harness from the engine
  3. Drain the engine coolant. *See Drain, Flush, and Re-fill the Coolant System with New Coolant on page 5-21.* Disconnect the radiator hoses from the engine.
  4. Drain the engine oil. *See Replace Engine Oil and Engine Oil Filter on page 5-13.*
  5. Disconnect the exhaust system from the exhaust manifold.
  6. Remove the engine from the vehicle. Fix the engine on a horizontal base.

### CAUTION

**Be sure to fix the engine securely to prevent injury or damage to parts due to falling during the work.**

---

7. Clean the engine by washing with solvent, air or steam cleaning. Carefully operate so as to prevent any foreign matter from entering the engine.

Cylinder Head Components

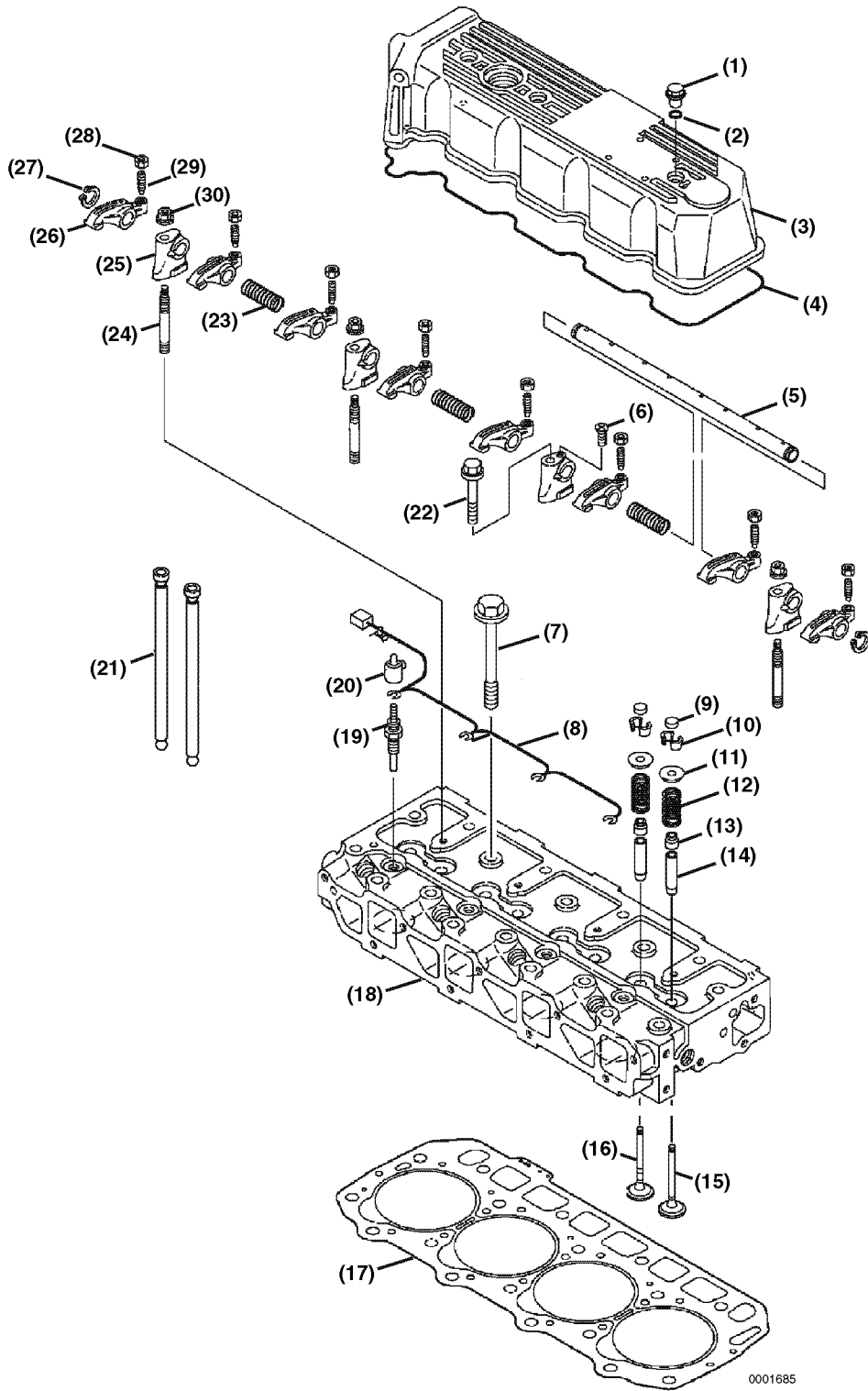

Figure 6-1

1. Valve Cover Nut
2. Valve Cover Nut O-ring
3. Valve Cover
4. Valve Cover Gasket
5. Rocker Arm Shaft
6. Rocker Arm Shaft Retaining Screw
7. Cylinder Head Bolt
8. Glow Plug Harness
9. Valve Cap
10. Valve Keepers
11. Spring Retainer
12. Valve Spring
13. Valve Stem Seal
14. Valve Guide
15. Intake Valve
16. Exhaust Valve
17. Cylinder Head Gasket
18. Cylinder Head
19. Glow Plug
20. Glow Plug Cover
21. Push Rod
22. Support Bracket Bolt
23. Rocker Arm Shaft Spring
24. Support Bracket Stud
25. Support Bracket
26. Rocker Arm
27. Rocker Arm Shaft Retaining Ring
28. Valve Adjusting Screw Lock Nut
29. Valve Adjusting Screw
30. Support Bracket Nut

## Disassembly of Cylinder Head

Prepare a clean, flat working surface on a workbench large enough to accommodate the cylinder head assembly. Discard all gaskets, O-rings and seals.

### NOTICE

Identify all parts and their location using an appropriate method. It is important that all parts are returned to the same position during the assembly process.

1. Remove the intake manifold bolts (**Figure 6-2, (1)**). Remove the intake manifold (**Figure 6-2, (3)**). Discard the intake manifold gasket (**Figure 6-2, (3)**).

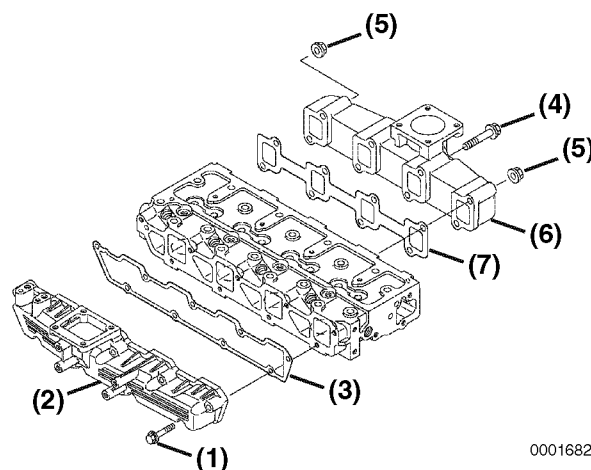

0001682

**Figure 6-2**

2. Remove the exhaust manifold bolts (**Figure 6-2, (4)**) and nuts (**Figure 6-2, (5)**). Remove the exhaust manifold (**Figure 6-2, (6)**). Discard the exhaust manifold gasket (**Figure 6-2, (7)**).
3. Remove the water pump from the engine. See *Disassembly of Engine Coolant Pump* on page 8-7.
4. Remove the fuel injectors from the cylinder head. See *Removal of the Fuel Injectors* on page 7-35.

## Removal of Glow Plugs

1. Remove the glow plug cover (**Figure 6-3, (2)**) from each of the glow plugs (**Figure 6-3, (1)**).
2. Disconnect the glow plug harness (**Figure 6-3, (3)**) from the glow plugs.
3. Remove the glow plugs from the cylinder head (**Figure 6-3, (4)**).

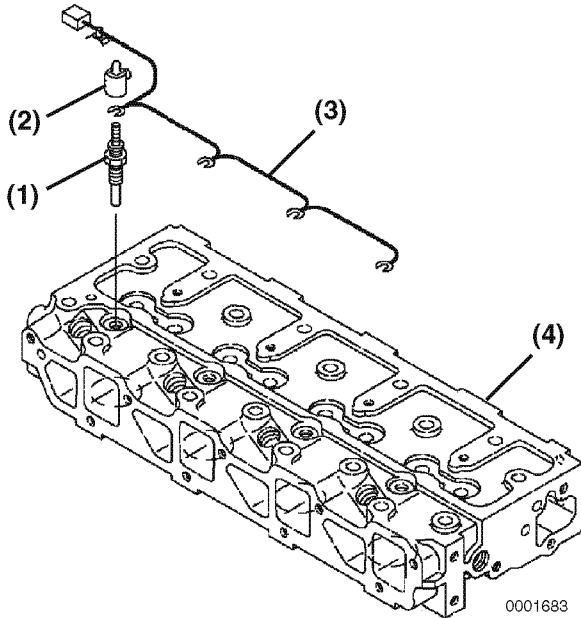

**Figure 6-3**

## Removal of Valve Cover

1. Remove the valve cover nuts (**Figure 6-4, (1)**).
2. Check the condition of the O-ring (**Figure 6-4, (2)**) on each valve cover nut. Replace the O-ring if necessary.

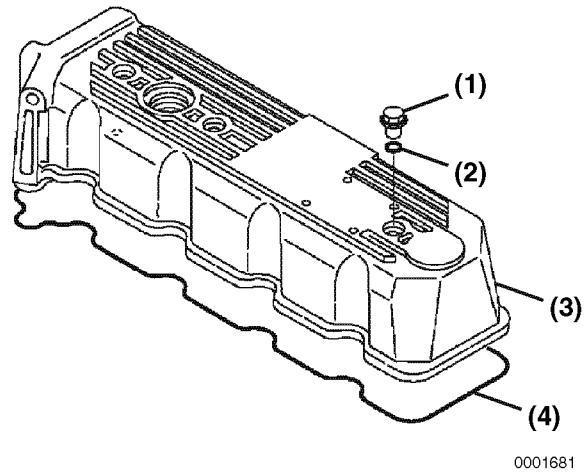

**Figure 6-4**

3. Remove the valve cover (**Figure 6-4, (3)**). Discard the valve cover gasket (**Figure 6-4, (4)**).

**Figure 6-5**

## Removal of Rocker Arm Assembly

1. Remove the bolt (**Figure 6-6, (1)**) and locking nuts (**Figure 6-6, (2)**) that retain the rocker arm support brackets to the cylinder head.
2. Lift the rocker arm assembly from the cylinder head.
3. Lift the push rods from the cylinder head.
4. Number the push rods so that they are reinstalled with the same valve tappet and rocker arm.



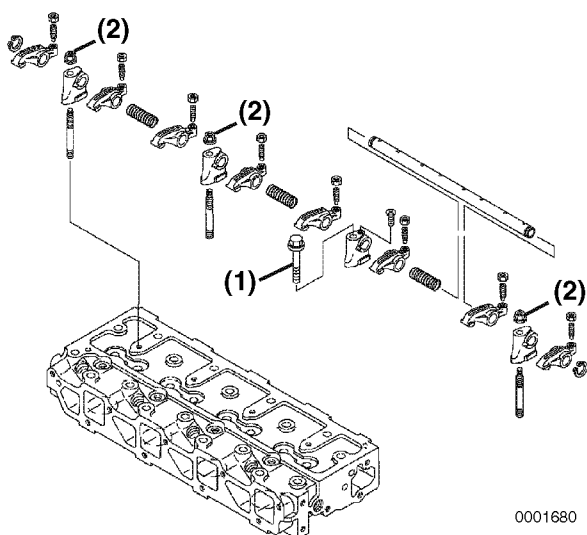

Figure 6-6

**Disassembly of Rocker Arm Assembly**

1. Remove the rocker arm shaft alignment screw (Figure 6-7, (1)) from the support bracket that secures the rocker arm shaft (Figure 6-7, (2)).
2. Remove the retaining rings (Figure 6-7, (3)) from the ends of the rocker arm shaft (Figure 6-7, (2)).
3. Slide the rocker arm shaft (Figure 6-7, (2)) out of the rocker arm support brackets (Figure 6-7, (4)), springs (Figure 6-7, (5)), and rocker arms (Figure 6-7, (6)).

Note: The rocker arm shaft fits tightly in the rocker arm support brackets. Clamp the support bracket in a padded vise and twist the rocker arm shaft to remove. Reverse this process when you reinstall the rocker arm shaft into the support brackets.

Note: Mark the rocker arms so they can be reinstalled with the original matching valve and pushrod.

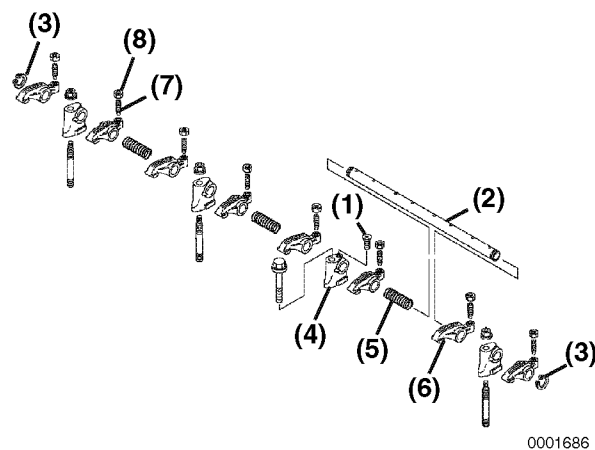
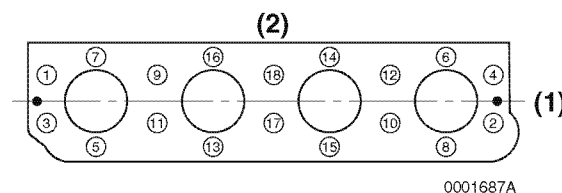

Figure 6-7

4. If necessary, remove the valve adjusting screw (Figure 6-7, (7)) and lock nut (Figure 6-7, (8)) from the rocker arms.

**Removal of Cylinder Head**

1. Loosen the cylinder head bolts following the sequence shown in (Figure 6-8).



1. Fan Side
2. Camshaft Side

Figure 6-8

2. Remove the cylinder head bolts (Figure 6-9, (1)).
3. Lift the cylinder head away from the cylinder block. Discard the cylinder head gasket (Figure 6-9, (2)). Position the cylinder head on the work bench to prevent damage to the combustion surface.

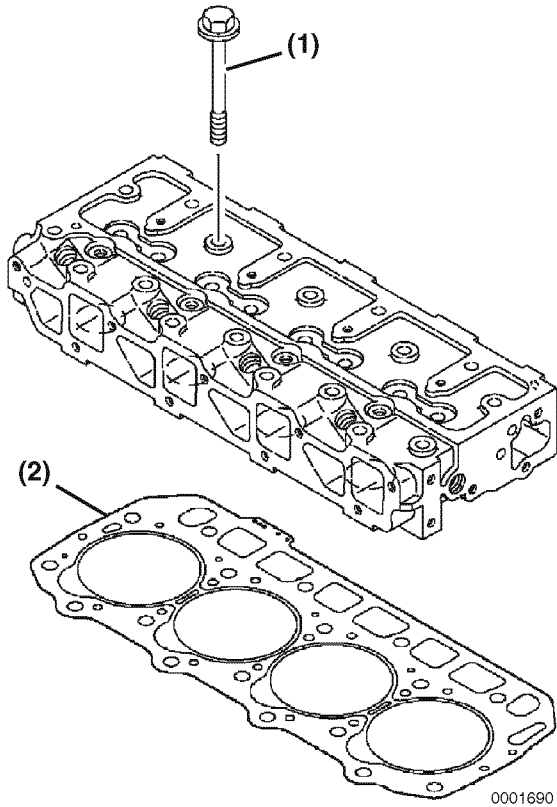

**Figure 6-9**

### Removal of Intake / Exhaust Valves

1. Place the cylinder head on the work bench with the combustion side down.
2. Using the valve spring compressor tool, compress one of the valve springs (Figure 6-10).

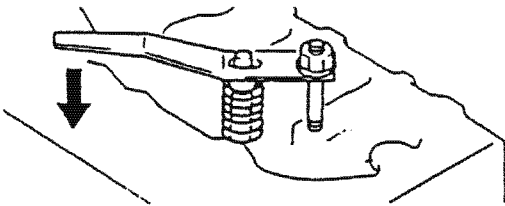

**Figure 6-10**

3. Remove the valve keepers (Figure 6-11, (2)) and valve cap (Figure 6-10, (1)) from the end of the valve.

4. Slowly release the tension on the valve spring.
5. Remove the spring retainer (Figure 6-11, (3)), valve spring (Figure 6-11, (4)) and valve stem seal (Figure 6-11, (5)).

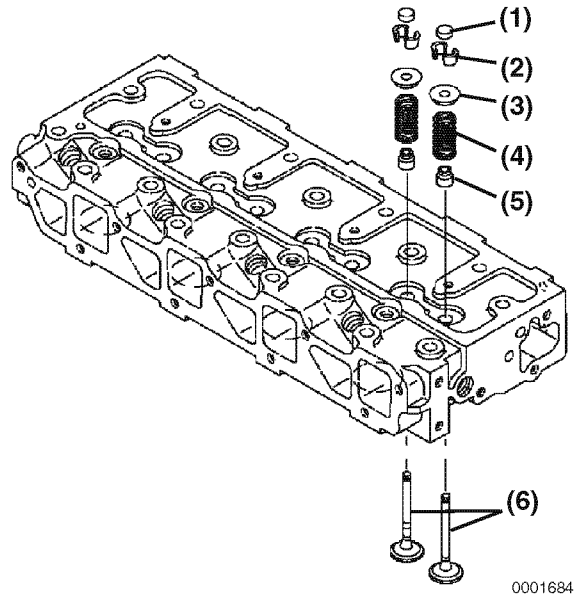

**Figure 6-11**

6. Repeat this procedure until all the intake and exhaust valve springs and valve stem seals are removed.

Note: If you are going to reinstall the valves in the cylinder head, mark them so they can be installed in their original location.

7. Turn the cylinder head so the exhaust port side faces down. Remove the intake and exhaust valves (Figure 6-11, (6)) from the cylinder head.

### Removal of Valve Guides

1. Using a drift pin and hammer, drive the valve guides (Figure 6-12, (1)) out of the cylinder head.

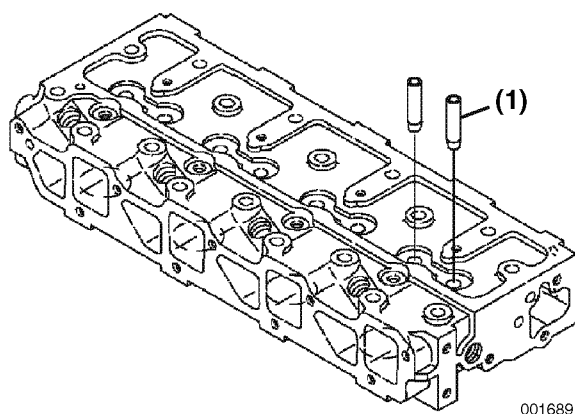

**Figure 6-12**

## Cleaning of Cylinder Head Components

Thoroughly clean all components using a non-metallic brush and an appropriate solvent. Each part must be free of carbon, metal filings and other debris.

## Inspection of Cylinder Head Components

Visually inspect the parts. Replace any parts that are obviously discolored, heavily pitted or otherwise damaged. Discard any parts that do not meet its specified limit.

### NOTICE

Any part which is found defective as a result of inspection or any part whose measured value does not satisfy the standard or limit must be replaced.

Any part determined to not meet the service standard or limit before the next service, as determined from the state of current rate of wear, should be replaced even though the part currently meets the service standard or limit.

## Inspection of Push Rods

### Push Rod Straightness

Determine if the straightness of the push rods are within the specified limit.

1. Place the push rods on a flat inspection block or layout bed.
2. Roll the push rods until a gap can be observed between a portion of the push rod and the surface of the block or layout bed.
3. Use a feeler gauge to measure the gap (**Figure 6-13**). See *Push Rod* on page 6-4 for the service limit.

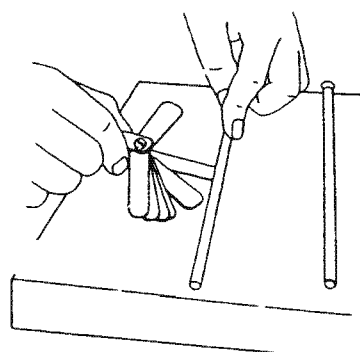
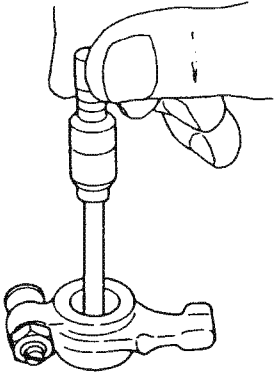

**Figure 6-13**

## Inspection of Rocker Arm Assembly

### Arm Shaft Hole Diameter

Use a test indicator and micrometer to determine if the inside diameter of all the rocker arm support brackets and the rocker arms (**Figure 6-14**) are within the specified limits. See *Rocker Arm and Shaft* on page 6-4 for the service limit.



**Figure 6-14**

### Shaft Outside Diameter

Use a micrometer to measure rocker arm shaft diameter in at least four places (**Figure 6-15**). See *Rocker Arm and Shaft* on page 6-4 for the service limit.

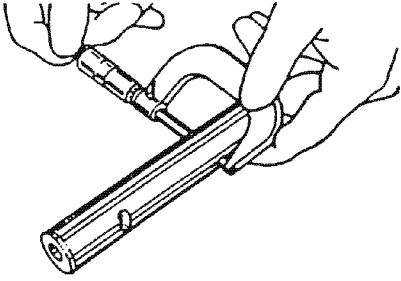

0000203

**Figure 6-15**

### Inspection of Valve Guides

#### Guide Inside Diameter

Visually inspect the valve guides for distortions, scoring or other damage.

Use a test indicator and micrometer to measure the inside diameter at each end of the valve guide. See *Intake / Exhaust Valve and Guide* on page 6-3 for the service limit.

### Inspection of Cylinder Head

#### Cylinder Head Distortion

Place the cylinder head flat and inverted (combustion side up) on the bench. Use a straight edge and feeler gauge to measure the amount of cylinder head distortion (**Figure 6-16**). See *Cylinder Head* on page 6-3 for the service limit.

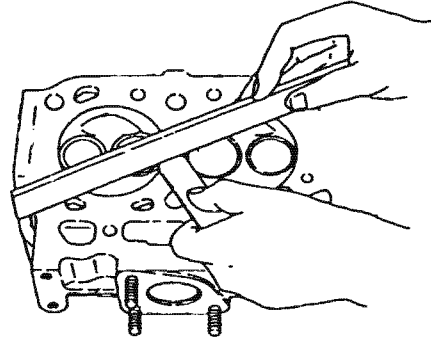

0000192

**Figure 6-16**

### Inspection of Intake and Exhaust Valves

Visually inspect the intake and exhaust valves. Replace any valves that are obviously discolored, heavily pitted or otherwise damaged.

#### Valve Stem Diameter

Use a micrometer to measure the valve stem diameter. Measure the valve stem near the combustion end and near the opposite end (**Figure 6-17**). See *Intake / Exhaust Valve and Guide* on page 6-3 for the service limit.

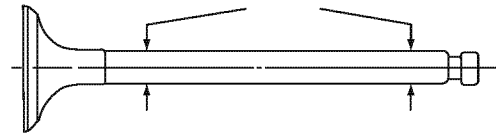

0000197

**Figure 6-17**

### Valve Stem Straightness

Place the valve stem on a flat inspection block or layout bed. Roll the valve until a gap can be observed between a portion of the valve stem and the surface of the block or bed. Use a feeler gauge to measure the gap (**Figure 6-18**). See *Intake / Exhaust Valve and Guide* on page 6-3 the service limit.

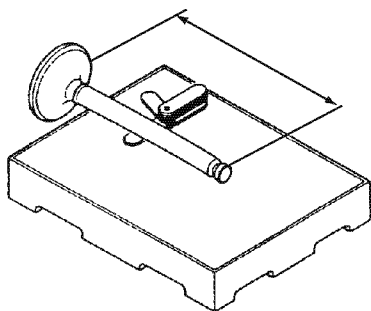

0000199

**Figure 6-18**

### Valve Sink

Insert the valves into their proper places and press them down until they are fully seated. Use a depth micrometer (**Figure 6-19**) to measure the difference between the cylinder head surface and the combustion surface of each exhaust and intake valve (**Figure 6-20**). See *Cylinder Head* on page 6-3 for the service limit.

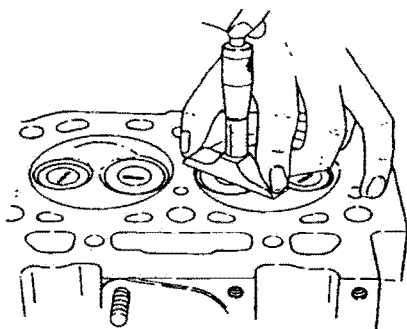

0000193

**Figure 6-19**

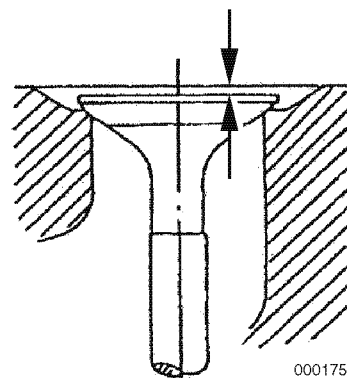

0001755

**Figure 6-20**

### Valve Seat

Always check the clearance between the valve and valve guide before correcting the valve seat (**Figure 6-21, (1)**). If the clearance exceeds the limit, replace the valve or valve guide to bring the clearance within the limit.

Roughness, or burrs will cause poor seating of a valve. Visually inspect the seating of each valve and determine if lapping or grinding is needed. Grinding is needed if the cylinder head's seat width exceeds standard limits. See *Cylinder Head* on page 6-3 for the service limit.

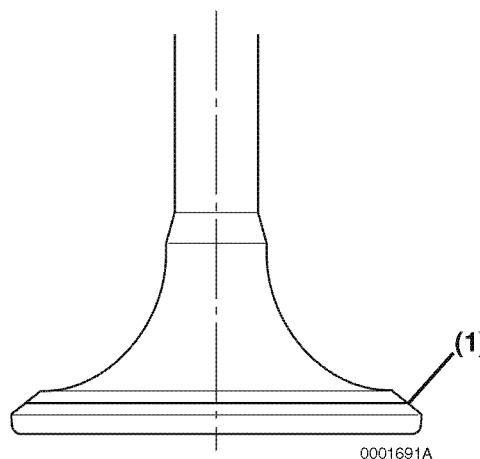

0001691A

**Figure 6-21**

Lap the valve seat and cylinder head with a mixture of valve compound and engine oil.

# ENGINE

If the valve requires grinding, lap the valve after grinding.

Be sure to thoroughly wash the parts to remove all grinding powder or compound.

## Inspection of Valve Springs

Inspect the valve springs. If damage or corrosion is seen, or if measurements exceeds the specified limits, replace the springs.

### Fractures

Check for fractures on the inside and outside portions of the springs. If the valve spring is fractured, replace the valve spring.

### Corrosion

Check for corrosion of spring material caused by oxidation.

### Square

Use a flat surface and a square to check each spring for squareness (**Figure 6-22**). See *Valve Spring* on page 6-4 for the service limit.

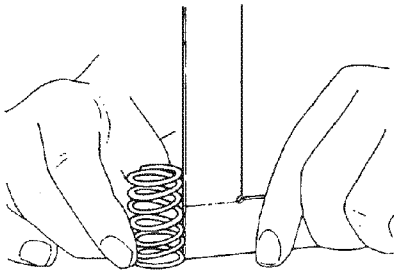

0000201

**Figure 6-22**

### Free Length

Use a caliper to measure the length of the spring (**Figure 6-23**). See *Valve Spring* on page 6-4 for the service limit.

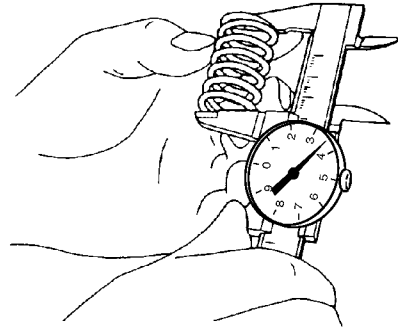

0000200

**Figure 6-23**

## Assembly of Cylinder Head

### Assembly of Valve Guides

1. The valve guides are installed into the cylinder head with an extremely tight press fit. Before installing the valve guides, place the valve guides in a freezer for at least twenty minutes. This will cause the valve guides to contract, making it easier to install the valve guides into place.
2. Immediately after removing the valve guides from the freezer, insert the valve guides (**Figure 6-24, (1)**) in their proper positions.

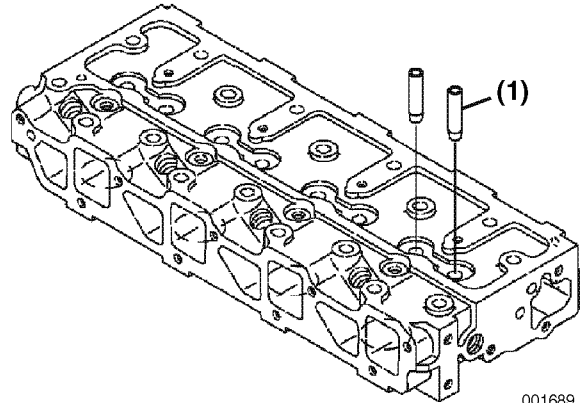

001689

**Figure 6-24**

3. Finish installing the valve guides (Figure 6-25, (1)) into the cylinder head to the proper height (Figure 6-25, (3)) using the valve guide installation tool (Figure 6-25, (2)). See *Intake / Exhaust Valve and Guide on page 6-3*.

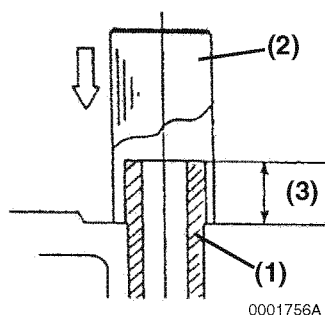
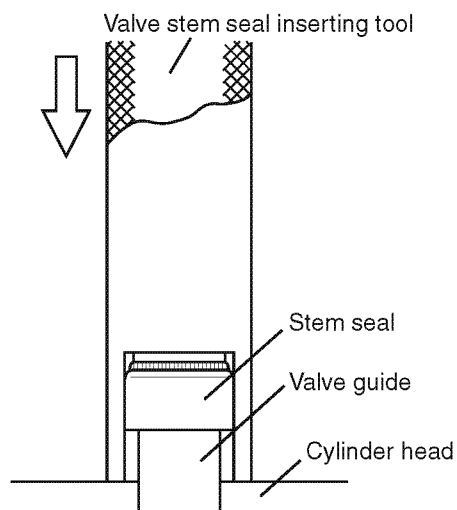

Figure 6-25



Stem seal Insertion

0001757

Figure 6-27

### Assembly of Intake and Exhaust Valves

1. Place the cylinder head assembly on its exhaust port side.
2. Place all the valves (Figure 6-26, (6)) in their proper place in the cylinder head.

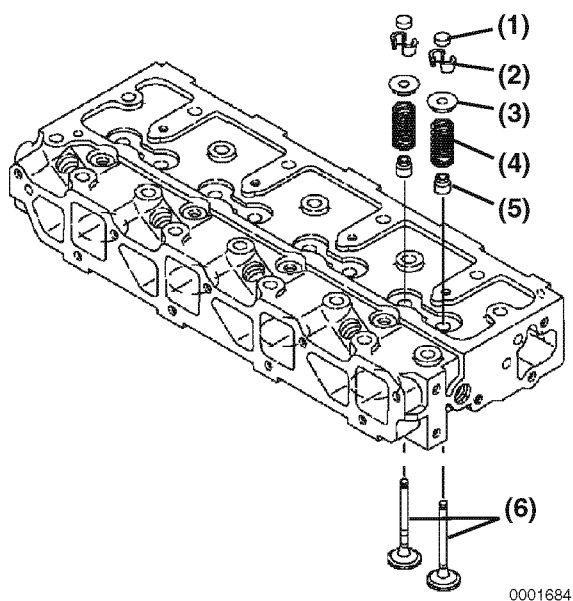

Figure 6-26

3. Oil the lip of the valve stem seal. Using the valve stem seal installation tool, insert a new valve stem seal (Figure 6-26, (5)) on each of the valves.

- Measure the distance from the cylinder head to the valve stem seal. See *Intake / Exhaust Valve and Guide on page 6-3*.

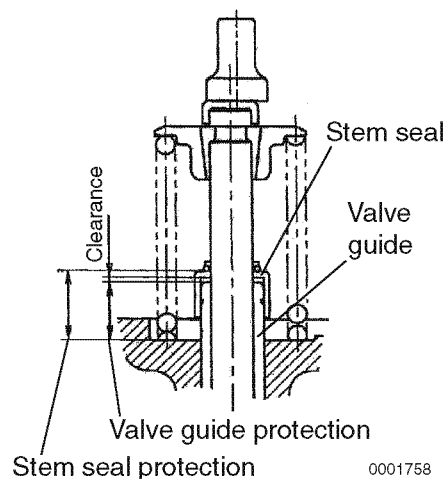

Figure 6-28

4. Place the cylinder head on the workbench with the combustion side down to install the valve springs. Install the valve spring (Figure 6-26, (4)) and spring retainer (Figure 6-26, (5)).
5. Using the valve spring compressor tool, compress the valve spring.

# ENGINE

6. Insert the valve keepers (**Figure 6-26, (2)**) and slowly release the tension in the valve spring. Install the valve cap (**Figure 6-26, (1)**). Repeat these steps until all the intake and exhaust valves are installed.

## Assembly of Cylinder Head

1. Carefully clean both the combustion surface of the cylinder head and the top surface of the cylinder block. Then place a new cylinder head gasket (**Figure 6-29, (2)**) on the cylinder block.
2. Position the cylinder head on the on the cylinder head gasket.

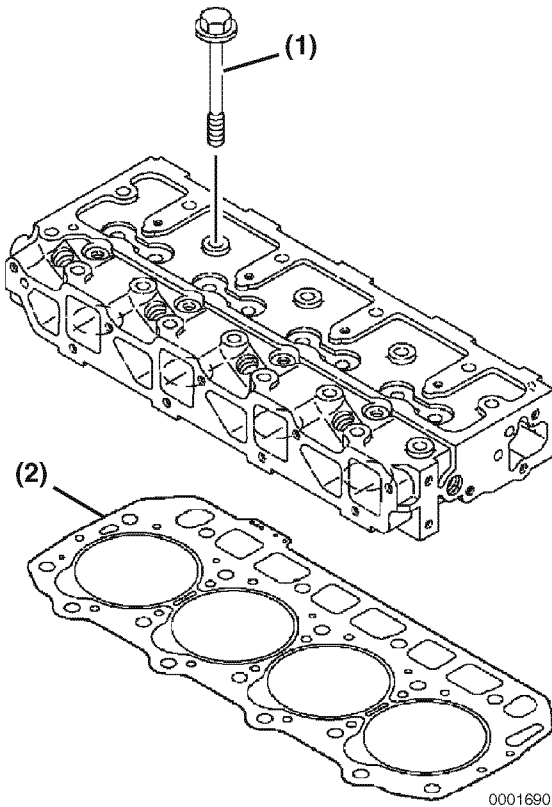

**Figure 6-29**

3. Lightly oil the threads of the cylinder head bolts (**Figure 6-29, (1)**). Torque the bolts in steps to the specified torque in table following the sequence in (**Figure 6-30**).

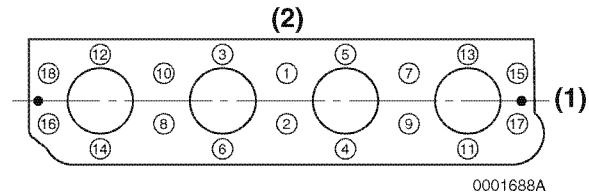

1. Fan Side
2. Camshaft Side

**Figure 6-30**

First Step	11 - 13 ft lbs (49-58.8 N m) (5 - 6 kgf m)
Second Step	23 - 25 ft lbs (103.1 - 112.9 N m) (10.5 - 11.5 kgf m)

4. Insert the push rods in their respective positions.

## Assembly of Rocker Arm Assembly

1. Lubricate the rocker arm shaft. Slide the rocker arm support brackets (**Figure 6-30, (4)**), springs (**Figure 6-30, (5)**) and rocker arms (**Figure 6-30, (6)**) onto the shaft.

Note: The rocker arm shaft fits tightly in the rocker arm support brackets. Clamp the support bracket in a padded vise and twist the rocker arm shaft to remove. Reverse this process when you reinstall the rocker arm shaft into the support brackets.

Note: To properly align the rocker arm shaft with the rocker arm shaft supports, first install the rocker arm support bracket (**Figure 6-31, (4)**) with the hole for the shaft alignment screw (**Figure 6-31, (1)**). Align the hole in the rocker arm shaft and the hole in the rocker arm support bracket. Install the alignment screw.



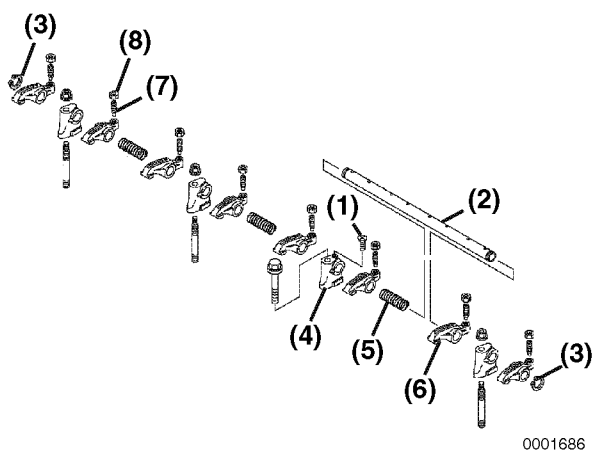

0001686

Figure 6-31

2. Position the rocker arm assembly on a flat surface. Install the retaining rings (Figure 6-31, (3)) onto the end of the rocker arm shaft.
3. Install and hand tighten the rocker arm shaft retaining bolt and nuts.
4. Install the valve adjusting screws (Figure 6-31, (7)) and lock nuts (Figure 6-31, (8)).
5. Place the rocker arm assembly in place onto the cylinder head. Tighten the rocker arm support bracket nuts and bolt to the specified torque. Tighten the rocker arm shaft alignment screw.
6. Align the push rods with their respective rocker arms and adjust the valve lash. (See *Measuring and Adjusting Valve Clearance* on page 6-30.)

### Assembly of the Valve Cover

1. Lightly grease a new valve cover gasket (Figure 6-32, (4)). Place the gasket in the groove of the valve cover (Figure 6-32, (3)).
2. Place the valve cover on the cylinder head.
3. Be sure O-rings (Figure 6-32, (2)) are installed on the valve cover nuts. Install and tighten the valve cover nuts (Figure 6-32, (1)).

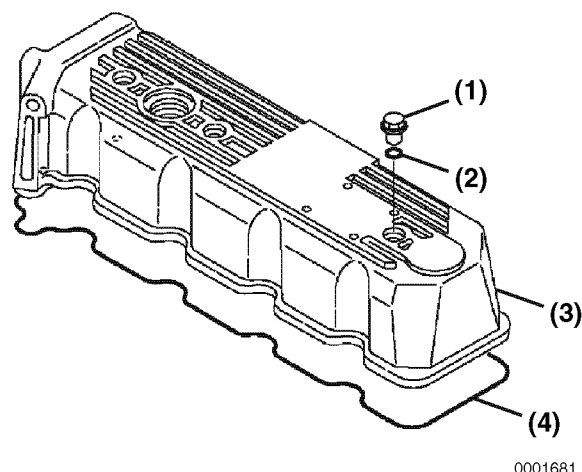

0001681

Figure 6-32

### Assembly of Glow Plugs

1. Install the glow plugs (Figure 6-33, (1)) into the cylinder head (Figure 6-33, (4)). Torque the glow plugs to the specified torque.
2. Connect the glow plug harness (Figure 6-33, (3)) to the glow plugs.
3. Install the glow plug cover (Figure 6-33, (2)) on each glow plug.

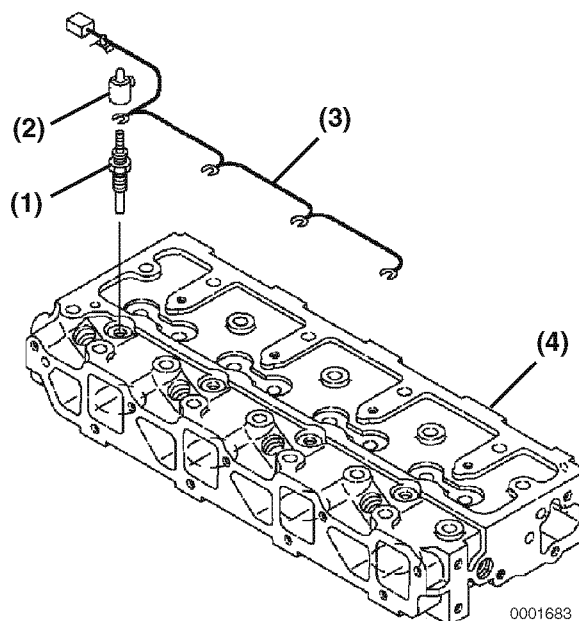

0001683

Figure 6-33

## MEASURING AND ADJUSTING VALVE CLEARANCE

Make measurement and adjustment while the engine is cold.

### Valve Clearance Measurement

1. Remove the valve cover.
2. Rotate the crankshaft clockwise as seen from the radiator side, to bring No.1 piston to TDC while watching the rocker arm motion, timing scale and the top mark position of the crankshaft pulley. (Position where both the intake and exhaust valves are closed.)

#### Notes:

- The No. 1 piston position is on the flywheel end of the engine, opposite side of the radiator, and the ignition order shall be 1-3-4-2-1 at 180° intervals.
  - Since the intake and exhaust valve rocker arms are operated the same and there is a clearance between rocker arm and valve generally at the top dead center, the position can be checked by means of the play when the arm head is held with a hand. Also see that the crankshaft pulley top mark is positioned at zero on the timing scale. If there is no valve clearance, inspection in the disassembled state is necessary since the valve seat may be worn abnormally.
3. Insert a feeler gauge (**Figure 6-34, (1)**) between rocker arm and valve cap, and record the measured valve clearance. (Use the data for estimating the wear.)

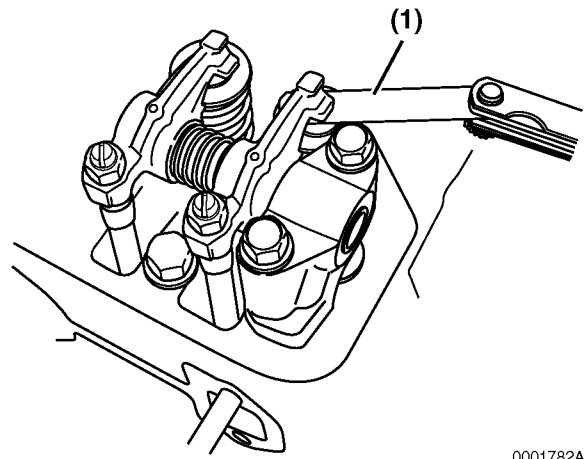

0001782A

**Figure 6-34**

4. Rotate the crankshaft 180° then make adjustment for the No. 3 cylinder. Then adjust the No. 4 cylinder and No. 2 cylinders in this order. The cylinder to be adjusted first does not have to be the No. 1 cylinder. Select and adjust the cylinder where the piston is nearest to the top dead center after turning, and make adjustment for other cylinders in the order of ignition by turning the crankshaft 180° each time.

## Valve Clearance Adjustment

1. Loosen the valve adjusting screw lock nut (**Figure 6-35, (1)**) and valve adjusting screw (**Figure 6-35, (2)**) on the rocker arm and check the valve for any inclination of valve cap, entrance of dirt or wear.

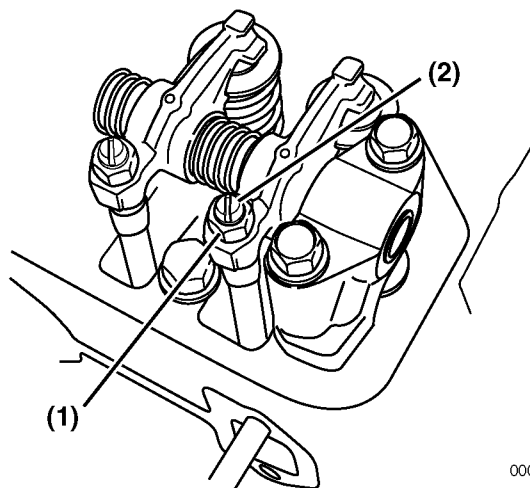

**Figure 6-35**

2. Insert a 0.008 in (0.2 mm) feeler gauge (**Figure 6-36, (1)**) between rocker arm and valve cap, and adjust the valve clearance so there is a slight "drag" on the feeler gauge when sliding it between the rocker arm and the valve cap. Tighten the valve adjusting screw lock nut (**Figure 6-35, (1)**) and recheck the clearance.

Note: There is a tendency for the clearance to decrease slightly when the lock nut is tightened. It is suggested that you make the clearance adjustment slightly on the "loose" side before tightening the lock nut.

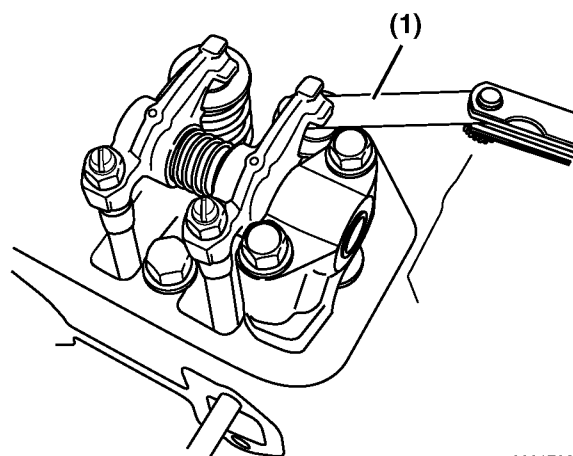

0001782A

**Figure 6-36**

Item	Standard
Valve Clearance	0.006 - 0.010 in (0.15 - 0.25 mm)

3. Apply oil to the contact surface between adjusting screw and push rod.
4. Turn the crankshaft 180° then make adjustment for the No. 3 cylinder. Then adjust the No. 4 and No. 2 cylinders in this order. The cylinder to be adjusted first does not have to be the No. 1 cylinder. Select and adjust the cylinder where the piston is the nearest to the TDC after rotating and make adjustment for other cylinders in the order of ignition by turning the crankshaft 180° each time.

DRIVE TRAIN AND CAMSHAFT COMPONENTS

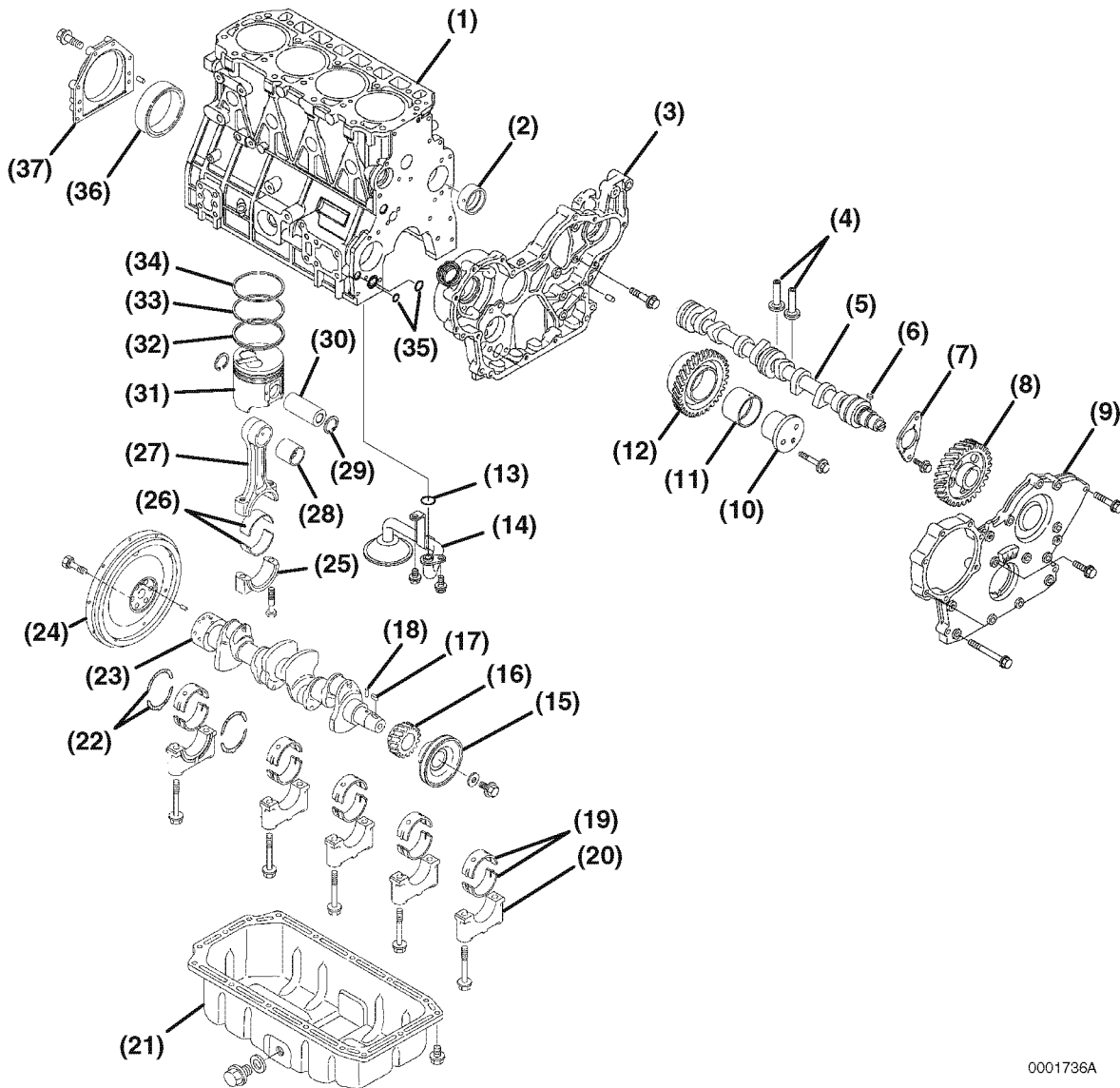

0001736A

Figure 6-37

1. Cylinder Block
2. Camshaft Bushing
3. Gear Case
4. Tappets
5. Camshaft
6. Camshaft Gear Key
7. Camshaft End Plate
8. Camshaft Gear
9. Gear Case Cover
10. Idler Gear Shaft
11. Idler Gear Bushing
12. Idler Gear
13. Oil Sump Pump O-ring
14. Oil Sump Pump
15. Crankshaft Pulley
16. Crankshaft Gear
17. Crankshaft Gear Key
18. Parallel Pin
19. Crankshaft Bearing Halves
20. Crankshaft Main Bearing Cap
21. Oil Pan
22. Thrust Bushings
23. Crankshaft
24. Flywheel
25. Connecting Rod Cap
26. Connecting Rod Bearing Halves
27. Connecting Rod
28. Wrist Pin Bushing
29. Circlip
30. Wrist Pin
31. Piston
32. Oil Ring
33. Second Compressor Ring
34. Top Compressor Ring
35. O-Rings
36. Crankshaft Rear Seal
37. Crankshaft Rear Seal Housing

## Disassembly of Drive Train and Camshaft Components

For ease of disassembly, inspection and reassembly, it is recommended that the engine be mounted in a suitable engine repair stand.

Prepare a clean, flat working surface on a workbench large enough to accommodate the engine components. Discard all used gaskets, O-rings and seals.

Remove the cylinder head. *See Disassembly of Cylinder Head on page 6-19.*

If necessary, remove the fuel injection pump. *See Removal of Fuel Injection Pump on page 7-28.*

### **NOTICE**

Identify all parts and their location using an appropriate method. It is important that all parts are returned to the same position during the assembly process.

# ENGINE

## Removal of Oil Pan

1. Invert the engine (oil pan up) on the engine stand.
2. Remove the oil pan bolts from the engine.

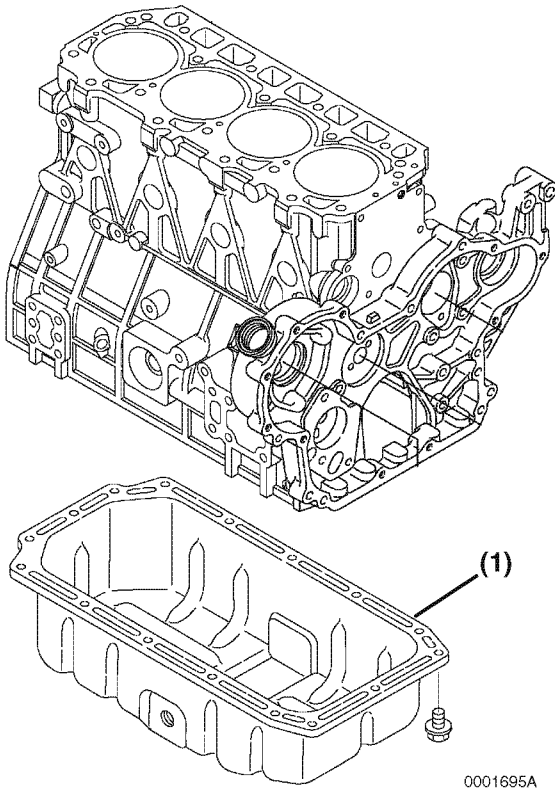
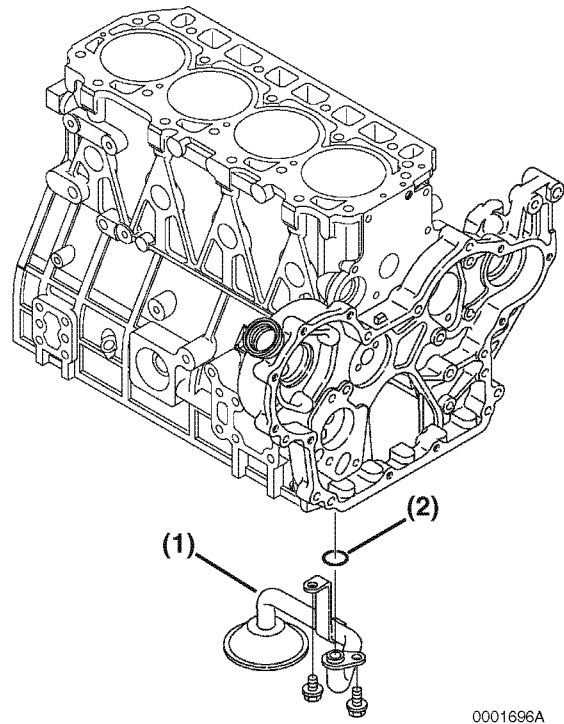

**Figure 6-38**

3. Remove the oil pan (**Figure 6-38, (1)**). Thoroughly clean all old sealant from the oil pan.

## Removal of Oil Sump Pump

1. Remove the two oil sump tube bolts.



**Figure 6-39**

2. Remove the oil sump tube (**Figure 6-39, (1)**) and O-ring (**Figure 6-39, (2)**).

## Removal of Timing Gears

Do not remove the camshaft gear from the camshaft.

1. Remove the bolt and washer retaining the crankshaft pulley.
2. Using a gear puller, remove the crankshaft pulley.
3. Remove the gear case cover (**Figure 6-40, (1)**).
  - Thoroughly clean all sealant from the cover and the gear case.
  - If necessary, remove the seal (**Figure 6-40, (2)**) from the cover.

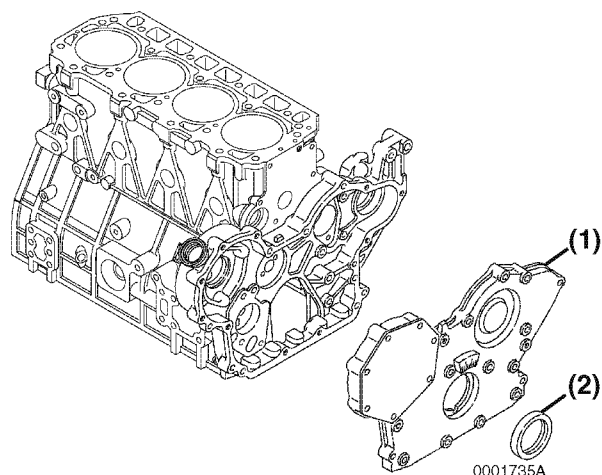

**Figure 6-40**

4. Remove the bolts from the timing gears.
  - Remove the crankshaft gear (**Figure 6-41, (1)**). If using a gear puller, be careful not to damage the treads in the end of the crankshaft. Remove the parallel pin (**Figure 6-41, (2)**) and the key (**Figure 6-41, (3)**) from the crankshaft.

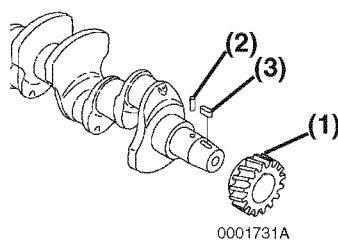

**Figure 6-41**

- Remove the bolts from the idler gear shaft. Remove the idler gear shaft (**Figure 6-42, (1)**), idler gear (**Figure 6-42, (2)**) and bushing (**Figure 6-42, (3)**).

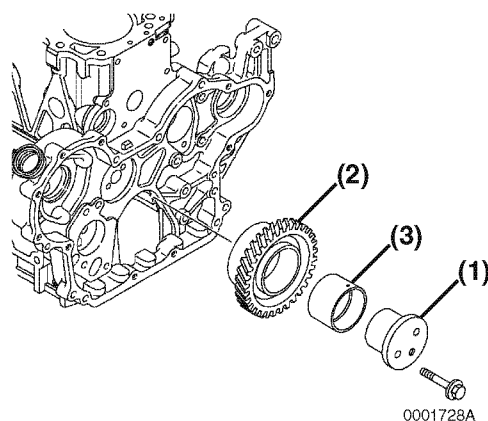

**Figure 6-42**

## Removal of Pistons

### NOTICE

Keep the piston pin parts, piston assemblies and connecting rod assemblies together to be returned to the same position during the reassembly process. Label the parts using an appropriate method.

Note: It is necessary to rotate the crankshaft to access some of the connecting rod assemblies at the bottom dead center position.

1. Using a feeler gauge, measure the connecting rod thrust clearance as shown (**Figure 6-43**). See *Connecting Rod* on page 6-8 for the standard limit. If the measurement is out of specification, either the crankshaft or the connecting rod must be replaced.

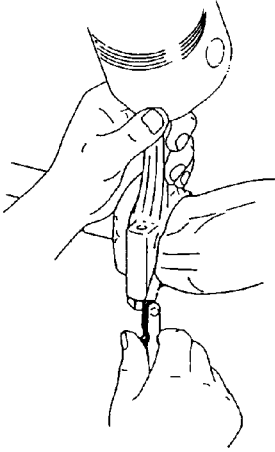

0000219

**Figure 6-43**

2. Remove the two bolts from one of the connecting rod caps (**Figure 6-44, (1)**).

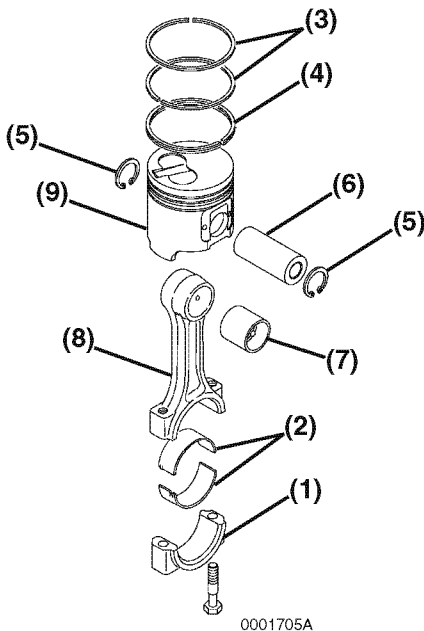

0001705A

**Figure 6-44**

3. Remove the connecting rod cap.
4. Remove the bearing halves (**Figure 6-44, (2)**).

5. Tap the piston through the cylinder and remove the piston assembly with the large portion of the connecting rod. Place this assembly on the bench. Mark the connecting rod caps and the connecting rods so the caps and connecting rods stay together.
6. Using a ring pliers, remove the two compression rings (**Figure 6-44, (3)**) from the piston.
7. Using a ring pliers, remove the oil seal ring (**Figure 6-44, (4)**) from the piston.
8. Using a snap-ring pliers, remove the circlips (**Figure 6-44, (5)**) from the wrist pin.
9. Disassemble the wrist pin (**Figure 6-44, (6)**), wrist pin bushing (**Figure 6-44, (7)**), connecting rod (**Figure 6-44, (8)**) and piston (**Figure 6-44, (9)**).
10. Repeat Steps 1 through 9 until all of the pistons are removed and disassembled.

## Removal of Crankshaft

1. Remove the flywheel bolts from the flywheel (**Figure 6-45, (1)**). Lift the flywheel away from the engine.
2. Remove the bolts from the rear oil seal assembly (**Figure 6-45, (2)**). Remove the assembly from the engine. Thoroughly clean all sealant from the oil seal housing.
3. Remove the rear oil seal (**Figure 6-45, (3)**) if necessary.

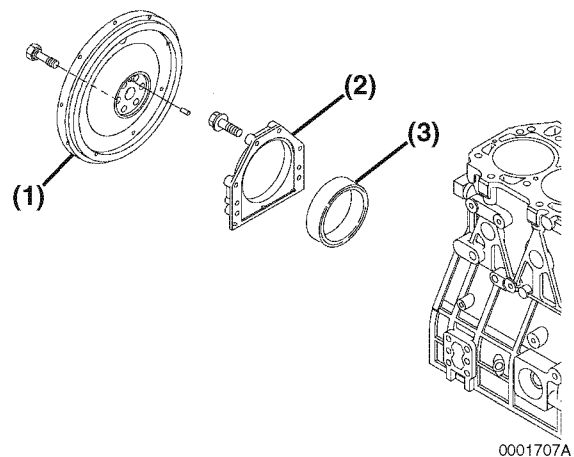

0001707A

**Figure 6-45**



4. Before removing the main bearing caps, measure the crankshaft side gap. Use either of the following two methods.

- The first method is to install a dial gauge on the cylinder block. Move the crankshaft back and forth. Measure the side gap. See *Thrust Bearing* on page 6-7 for the service limit.

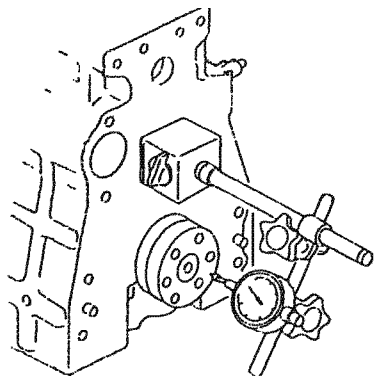

(Side gap measurement 1)

0001716

**Figure 6-46**

- The second method is to use a shim gauge and measure the clearance between the thrust metal and crankshaft.

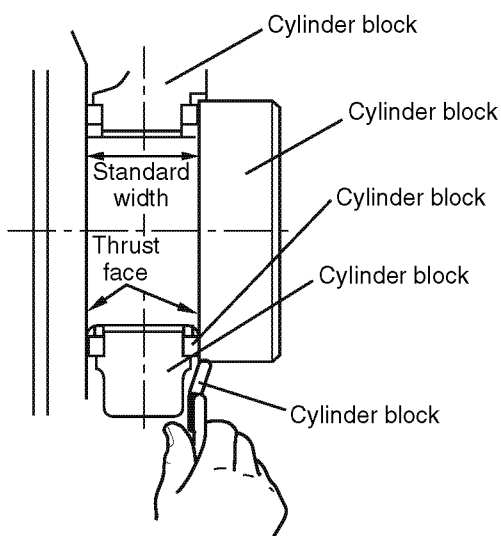

(Side gap measurement 2)

0001717

**Figure 6-47**

5. Remove the main bearings caps (**Figure 6-48, (1)**), the bearing halves (**Figure 6-48, (3)**) and the thrust bearings (**Figure 6-48, (2)**). Be sure to note the markings on the main bearing caps, or mark them yourself, so they can be reinstalled in the same order as they were removed.

Note: The “arrows” on the main bearing caps point to the flywheel end of the engine.

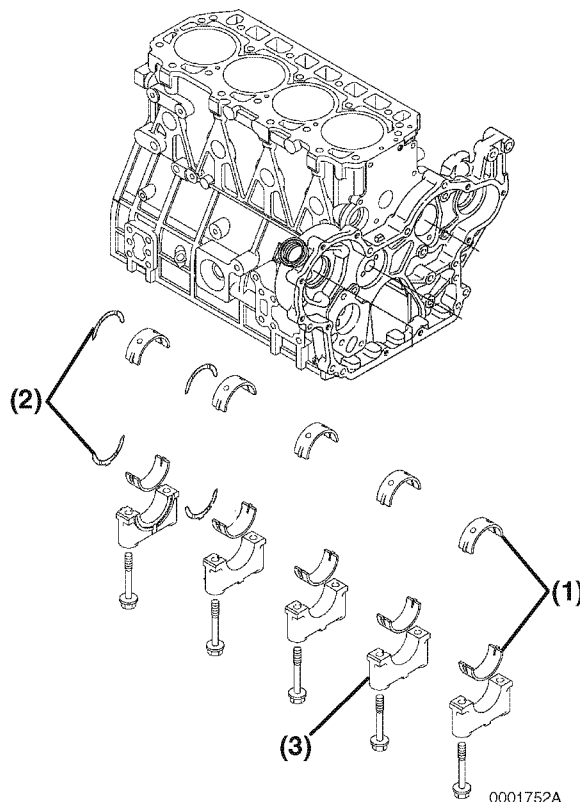
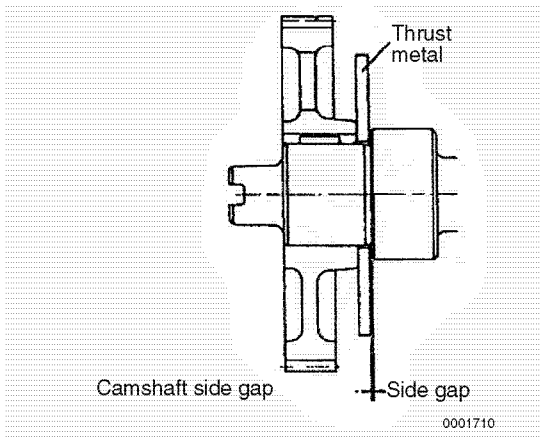

**Figure 6-48**

6. Remove the crankshaft from the engine.

**Removal of Camshaft**

1. Before removing the camshaft gear and camshaft, check the camshaft side gap.
  - Using a feeler gauge, measure the camshaft side gap. See *Camshaft* on page 6-5 for the service limit.



**Figure 6-49**

2. Using a gear puller, remove camshaft gear. Remove the key from the camshaft.
3. Remove the two bolts retaining the camshaft thrust plate (**Figure 6-50, (1)**). Remove the camshaft thrust plate.

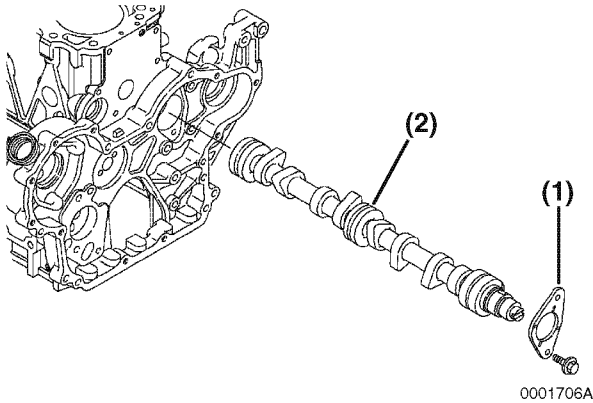

**Figure 6-50**

4. With the engine installed in an engine stand, rotate the engine so that gravity causes the tappets to drop away from the camshaft lobes. Slowly pull the camshaft (**Figure 6-50, (2)**) out of the engine.

Note: If the engine is not installed on an engine stand, position the engine with the mounting flange (flywheel end) facing down. Rotate the camshaft a few turns to bump the tappets out of the way to prevent the tappets from interfering with the removal of the camshaft

5. With the camshaft out of the way, remove the tappets. Mark the tappets so they can be reinstalled in the same location.

## Removal of Gear Case

1. Remove the gear case bolts.
2. Remove the gear case (**Figure 6-51, (1)**) from the cylinder block. Thoroughly clean all old sealant from the gear case and cylinder block.
3. If damaged, remove the camshaft bushing (**Figure 6-51, (3)**).
4. Remove the two O-rings (**Figure 6-51, (2)**) from the cylinder block.

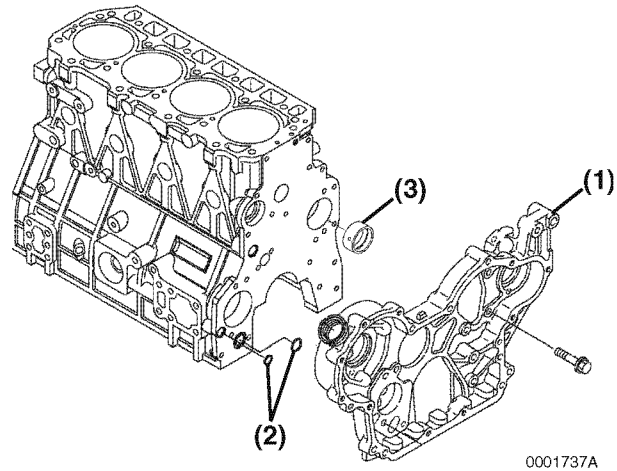

**Figure 6-51**

## Inspection of Drive Train and Camshaft Components

Thoroughly clean all of these components using a brush and an appropriate solvent. Each part must be free of carbon, metal filings and other debris.

### Inspection of Cylinder Block

1. Ensure that oil holes are clear and unobstructed. Clear any holes as needed.
2. Check for discoloration or evidence of cracks. If evidence of a fracture is found, use the color check method or the Magnaflux method to determine if the cylinder block is fractured.

3. Inspect cylinder roundness and cylindricity for evidence of distortions. Collect and record the measurements. (See *Cylinder Measurement Worksheet on page 6-40*). Perform the calculations as follows:

- Measure the inside diameter of cylinder number one, near the top of the cylinder (**a**) and in the (**d**) direction. Record that measurement as data **f**.
- Measure the inside diameter of cylinder number one, near the top of the cylinder (**a**) and in the (**e**) direction. Record that measurement as data **g**.
- Measure the inside diameter of cylinder number one, near the center of the cylinder (**b**) and in the (**d**) direction. Record that measurement as data **h**.
- Measure the inside diameter of cylinder number one, near the center of the cylinder (**b**) and in the (**e**) direction. Record that measurement as data **i**.
- Measure the inside diameter of cylinder number one, near the bottom of the cylinder (**c**) and in the (**d**) direction. Record that measurement as data **j**.
- Measure the inside diameter of cylinder number one, near the bottom of the cylinder (**c**) and in the (**e**) direction. Record that measurement as data **k**.
- **Roundness** - Roundness for cylinder number one is as calculated as follows:

$$f - g = X$$

$$h - i = Y$$

$$j - k = Z$$

**X** is the difference between the **f** and **g** measurements at the top of the cylinder.

**Y** is the difference between the **h** and **i** measurements at the top of the cylinder.

**Z** is the difference between the **j** and **k** measurements at the top of the cylinder.

Select the greatest of values **X**, **Y** and **Z** and record it as **V**. This value represents the **roundness** of the cylinder.

- **Cylindricity** - Cylindricity for cylinder number one is as calculated as follows:

Select the least value of values **X**, **Y** and **Z** record that value as **S**. Complete the calculation as follows:

$$V - S = W$$

**W** is the difference between the **L** and **S** measurements. This value represents the **cylindricity** of the cylinder.

Repeat the Cylindricity and roundness measurements and calculations for the remaining cylinders.

- ◆ Compare the worksheet findings with the data in the table.

Consider honing, re-boring or replacing the cylinder block if the measurements fall outside specification.

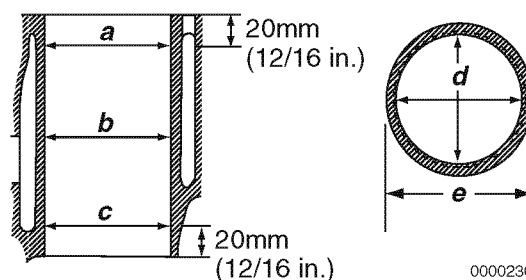

**Figure 6-52**

# ENGINE

## Cylinder Measurement Worksheet

Cylinder Number	Measurements			Calculated Values	
Cylinder # 1	Top (a)	Dimension (d) f = _____	Dimension (e) g = _____	$f - g = X$ X = _____	Greatest of X, Y and Z = V Roundness V = _____
	Center (b)	Dimension (d) h = _____	Dimension (e) i = _____	$h - i = Y$ Y = _____	Least of X, Y and Z = S S = _____
	Bottom (c)	Dimension (d) j = _____	Dimension (e) k = _____	$j - k = Z$ Z = _____	$V - S = W$ Cylindricity V = _____
Cylinder # 2	Top (a)	Dimension (d) f = _____	Dimension (e) g = _____	$f - g = X$ X = _____	Greatest of X, Y and Z = V Roundness V = _____
	Center (b)	Dimension (d) h = _____	Dimension (e) i = _____	$h - i = Y$ Y = _____	Least of X, Y and Z = S S = _____
	Bottom (c)	Dimension (d) j = _____	Dimension (e) k = _____	$j - k = Z$ Z = _____	$V - S = W$ Cylindricity V = _____
Cylinder # 3	Top (a)	Dimension (d) f = _____	Dimension (e) g = _____	$f - g = X$ X = _____	Greatest of X, Y and Z = V Roundness V = _____
	Center (b)	Dimension (d) h = _____	Dimension (e) i = _____	$h - i = Y$ Y = _____	Least of X, Y and Z = S S = _____
	Bottom (c)	Dimension (d) j = _____	Dimension (e) k = _____	$j - k = Z$ Z = _____	$V - S = W$ Cylindricity V = _____
Cylinder # 4 (As Needed)	Top (a)	Dimension (d) f = _____	Dimension (e) g = _____	$f - g = X$ X = _____	Greatest of X, Y and Z = V Roundness V = _____
	Center (b)	Dimension (d) h = _____	Dimension (e) i = _____	$h - i = Y$ Y = _____	Least of X, Y and Z = S S = _____
	Bottom (c)	Dimension (d) j = _____	Dimension (e) k = _____	$j - k = Z$ Z = _____	$V - S = W$ Cylindricity V = _____

### Inspection of Pistons

- Using a micrometer, measure the piston diameter at the skirt as shown (**Figure 6-53**). See *Piston* on page 6-7 for the service limit.

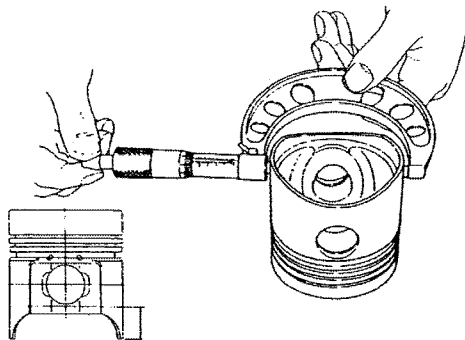

0000235

**Figure 6-53**

- Measure the piston ring and piston ring groove for cylinder number one.

- Using a micrometer, measure the thickness of the top compression ring. See *Piston Ring* on page 6-8 for the service limit.
- Place a properly-sized top compression ring in the groove as shown (**Figure 6-54**). Use a feeler gauge to measure the gap between the ring and the piston. See *Piston Ring* on page 6-8 for the service limit.

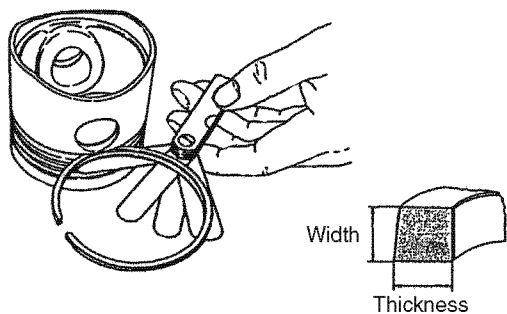

Measuring Side Clearance 0001732

**Figure 6-54**

- Add the top compression ring groove width and the top compression ring side clearance values together to determine the top ring groove width. See *Piston Ring* on page 6-8 for the service limit.
- Replace the piston if the values fall outside specification.
- Using a feeler gauge, measure the end gap clearance of the top compression ring. See *Piston Ring* on page 6-8 for the service limit.

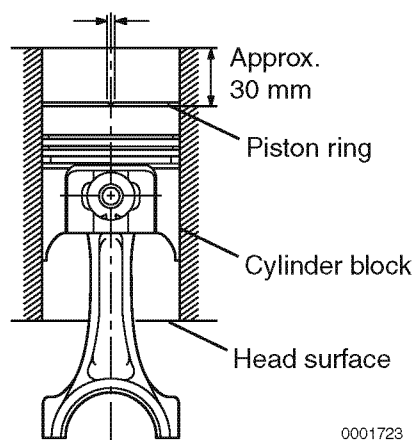

0001723

**Figure 6-55**

- Measure the rings and ring grooves for the second compression ring and oil ring using the same method used to measure the top compression ring and groove dimensions.
- Repeat these steps for each of the pistons.

### Inspection of Piston Pin

Measure the outside diameter of the piston pin and the inside diameter of the wrist pin bushing. Calculate the clearance between the piston pin and wrist pin bushing. See *Piston* on page 6-7 for the service limits.

Measure at positions a, b and c in directions A and B.

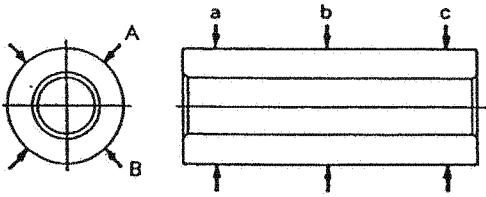

Piston pin outside diameter

0001721

Figure 6-56

## Inspection of Connecting Rod

1. Measure the inside diameter of the connecting rod small end. See *Connecting Rod* on page 6-8 for the service limit.

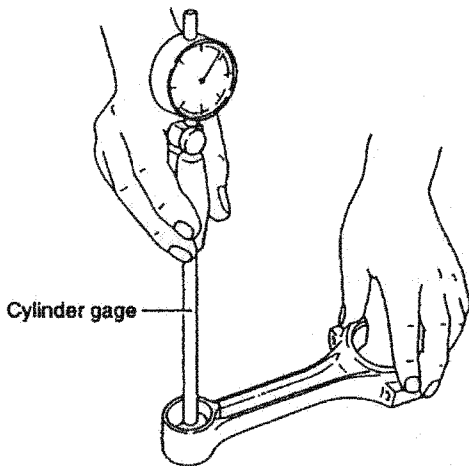

Connecting rod small end

0001724

Figure 6-57

2. Measure the crankpin and connecting rod bushings. Place the connecting rod bushings (bearing halves) into the connecting rod and connecting rod cap. Install the end of the connecting rod to the rod. Torque the bolts to the specified torque.
3. Measure the inside diameter. See *Crankshaft* on page 6-6 for the service limit.

## Inspection of Tappets

1. Check the tappet contact surfaces with the camshaft and push rods. Slight surface defects can be corrected using an oilstone.

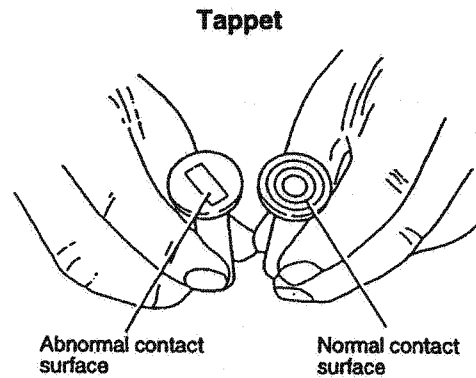

0001725

Figure 6-58

2. Measure the outside diameter of the tappet stem. See *Tappet* on page 6-9 for the service limit.

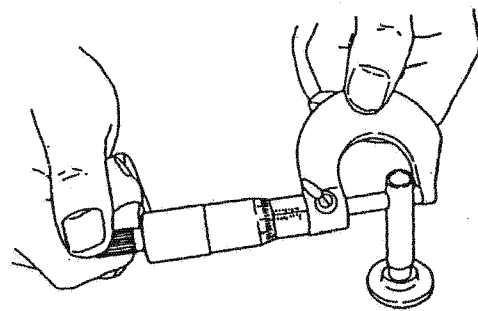

Tappet stem outside diameter measurement

0001726

Figure 6-59

## Inspection of Crankshaft

1. Measure the trueness of the crankshaft.
  - Place the crankshaft on V-blocks positioned at the end journals.
  - Place a dial indicator on a main bearing surface and "zero" the gauge.

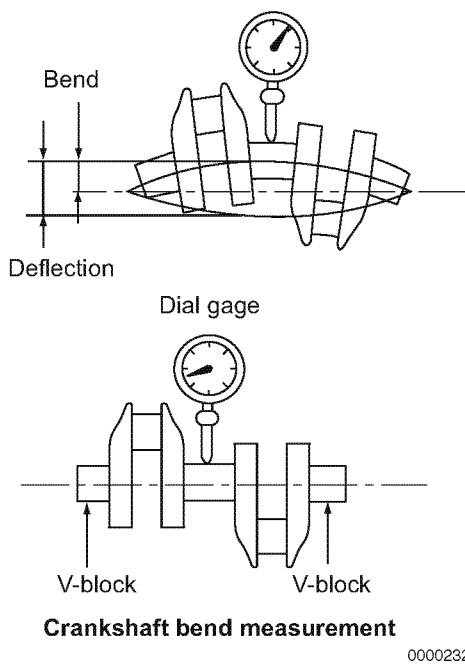

**Figure 6-60**

- Rotate the crankshaft and observe the runout. See *Crankshaft* on page 6-6 for the service limit.
  - Repeat this measurement operation for each of the remaining bearing surfaces.
2. Inspect the crankshaft for fractures.
- Using the color check method. Inspect the crankshaft for cracks. Replace the crankshaft if evidence of fractures are found.

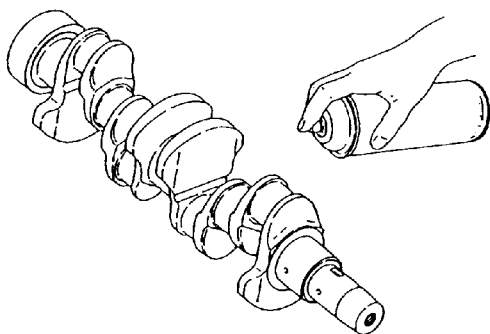

**Figure 6-61**

- If the color check method is not available, use the Magnaflux method. inspect the crankshaft for cracks. Replace the crankshaft if evidence of fractures are found.
3. Measure the outside diameter of each crankpin and journal.
- If the crankpin clearance exceeds the service limit, use an undersize bearing. See *Crankshaft* on page 6-6 for the service limit.
  - If the journal clearance exceeds the service limit, use an undersize bearing. See *Crankshaft* on page 6-6 for the service limit.

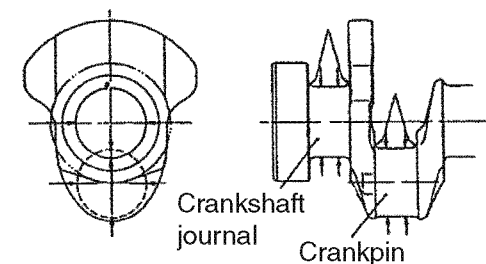
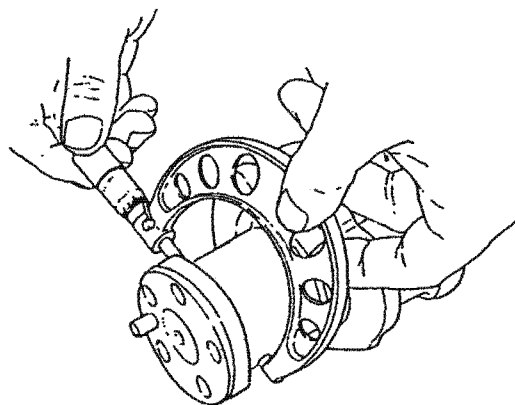

**Measuring position of the crankpin and crank journal**

0001733

**Figure 6-62**

**Inspection of Camshaft**

1. Measure the trueness of the camshaft.
- Place the camshaft on V-blocks positioned at the end journals.
  - Place a dial indicator on the gear side bearing surface and “zero” the gauge. (**Figure 6-63**)

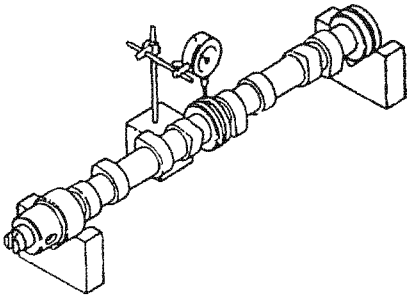

Figure 6-63

- Rotate the camshaft and observe the runout. See *Camshaft* on page 6-5 for the service limit.
2. Measure the intake / exhaust cam height (Figure 6-64, (1)). See *Camshaft* on page 6-5 for the service limit.

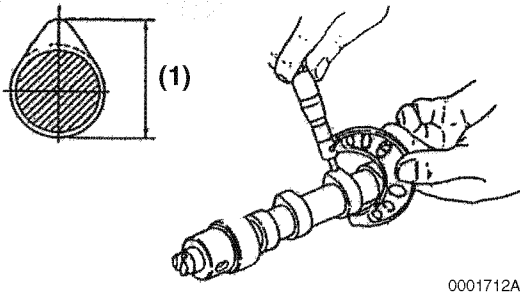
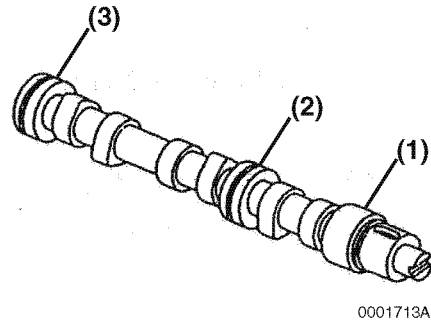

Figure 6-64

3. Measure the gear end (Figure 6-65, (1)), intermediate position (Figure 6-65, (2)) and flywheel end (Figure 6-65, (3)) bearing surface diameters. Determine the oil clearance. The oil clearance is calculated by subtracting the measured camshaft bearing surface diameter from the camshaft bushing inside diameter. See *Camshaft* on page 6-5 for the service limit.



0001713A

Figure 6-65

**Inspection of Camshaft Bushings**

If the camshaft bushing are damaged, replace the bushings using the appropriate service tool.

**Inspection of Idler Gear and Shaft**

1. Measure the outside diameter (Figure 6-66, (1)) of the idler gear shaft (Figure 6-65, (2)). See *Idler Gear Shaft and Bushing* on page 6-5 for the service limit.
2. Measure the inside diameter (Figure 6-65, (3)) of the idler gear (Figure 6-65, (4)). See *Idler Gear Shaft and Bushing* on page 6-5 for the service limit.

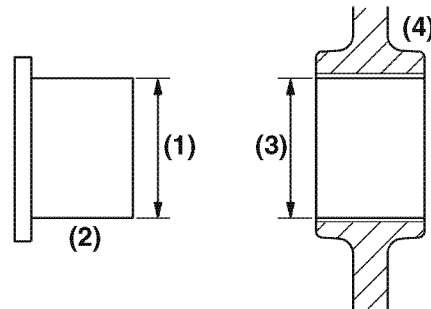

Idle gear

0001714A

Figure 6-66



## Honing and Boring

Pistons must move freely in the cylinders while maintaining adequate compression and oil sealing. If the cylinder walls are scuffed, scored, out of round or have poor cylindricity, boring or boring and honing might correct cylinder problems. Re-boring is necessary if the bore dimensions fall outside specified limits. Honing must follow any re-boring operations. Slight imperfections can be corrected by honing alone.

1. **Boring** - Significant cylinder damage might be corrected by re-boring.
  - Boring out a cylinder block can only be done in a properly equipped machine shop.
  - After re-boring, existing pistons must be replaced with over-sized pistons.
  - After re-boring a cylinder block, each cylinder must be honed.
2. **Honing** - Slight cylinder imperfections might be corrected by honing.

Note: Tilt the honing tool at a 30 to 40 degree angle during the honing operation, to leave a cross hatch mark on the cylinder wall. (Figure 6-67)

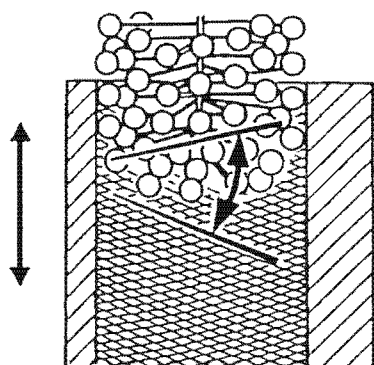

0000248

**Figure 6-67**

- Insert the appropriate honing tool in the chuck of an electric drill. (Figure 6-68)

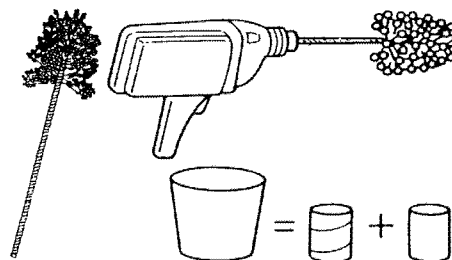

0000247

**Figure 6-68**

- Saturate the cylinder wall with solvent using a 50-50 mixture of diesel fuel and engine oil.

### NOTICE

Do not allow the honing tool to operate in one position for any length of time. Damage to the cylinder wall will occur. Keep the tool in constant up-and-down motion.

- Rotate the honing tool at 300 to 1200 rpm.
- Insert the rotating honing tool in the cylinder and move it down through the entire length of the cylinder in a five-second motion.

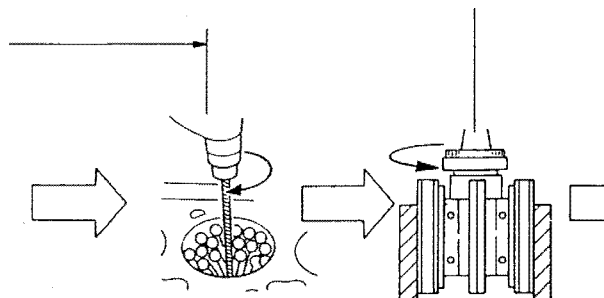

**Figure 6-69**

- Without stopping the honing tool, pull it up through the entire length of the cylinder in a five-second motion.
- Maintain the up-and-down motion for thirty to forty seconds.

# ENGINE

- When the honing is completed, wash the cylinder block with hot water and soap. Use brushes to clean all passages and crevices. Rinse with hot water and blow dry with compressed air. Apply engine oil to all steel surfaces to prevent rusting.

## Assembly of Drive Train and Camshaft Components

Notes:

- Proceed slowly. Make no forced assemblies unless a pressing operation is called for. All parts must be perfectly clean and lightly lubricated when assembled.
- Use new gaskets, seals and O-rings during assembly.

## Assembly of Pistons

1. Select the parts needed to assemble the piston and connecting rod for the No.1 cylinder.
2. Lubricate and insert the wrist pin bushing (**Figure 6-70, (1)**) into the small end of the piston rod.

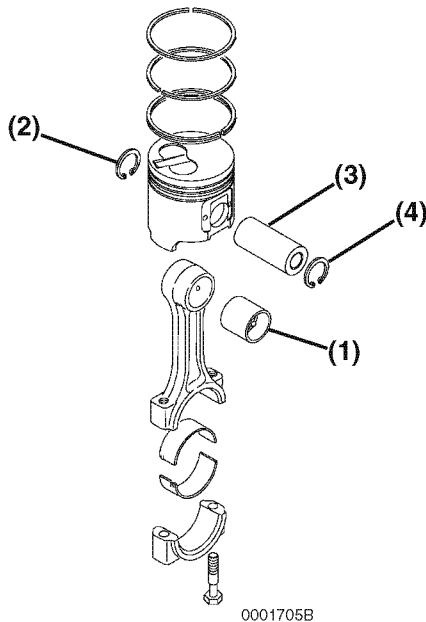

**Figure 6-70**

3. Install one circlip (**Figure 6-70, (2)**) into the piston.

4. Position the connecting rod into the piston under the skirt. The match marks on the connecting rod must be opposite of the piston identification mark (ID) on the top of the piston.

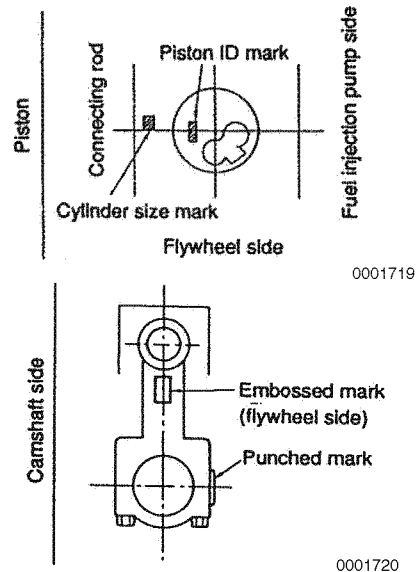

**Figure 6-71**

5. Lubricate and install the piston wrist pin (**Figure 6-70, (3)**) through the piston and wrist pin bushing.
6. Install the second circlip (**Figure 6-70, (4)**).
7. Install the piston rings:
  - Use piston ring pliers to install the piston rings.
  - Install each piston ring on the piston with the punched manufacturer's mark (**Figure 6-72, (1)**) facing upward.

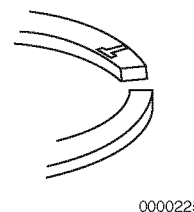

**Figure 6-72**

- Install the top compression ring, second compression ring and oil ring.

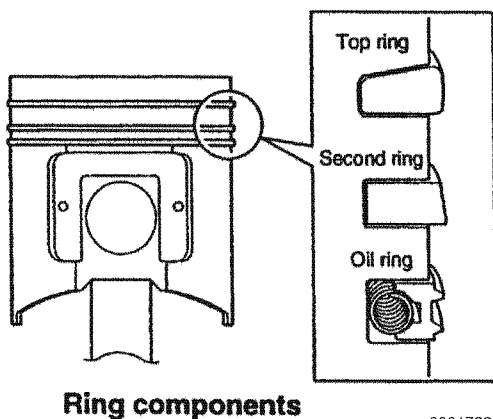

Ring components

0001722

Figure 6-73

- Stagger the piston ring joints at 120 intervals. Do not position the top piston ring joint inline with the piston wrist pin. The coil expander joint must be opposite the oil ring joint.

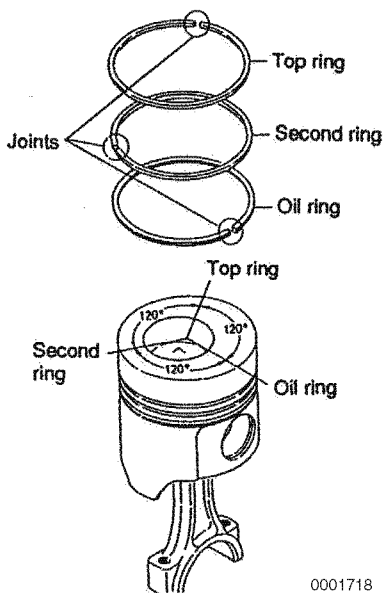

Figure 6-74

- Repeat these steps for the remaining pistons.

### Installation of Gear Case

1. If removed, install a new camshaft bushing (Figure 6-75, (3)).

2. Apply ThreeBond Liquid Gasket, Yanmar Part No. 977770-01212 to the mounting area of the gear case.
3. Be sure the two O-rings (Figure 6-75, (2)) are positioned in the cylinder block.
4. Install the gear case (Figure 6-75, (1)). Tighten the gear case bolts to the specified torque.

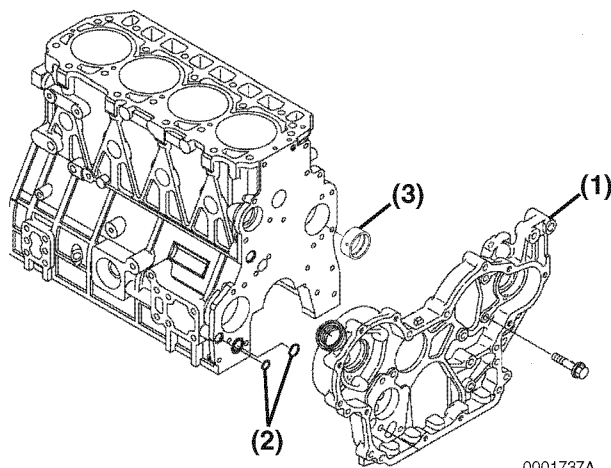

Figure 6-75

0001737A

### Installation of Crankshaft

1. Place the crankshaft into the engine.
2. Position the bearing halves (Figure 6-76, (1)), thrust bearing (Figure 6-76, (2)) and bearing caps (Figure 6-76, (3)) on the crankshaft.

Note: The numbers and arrows on the main bearing caps are for proper positioning. The caps are numbered 1, 2, 3 and 4 with the No. 1 cap at the flywheel. The arrows on the bearing caps point to the flywheel end of the engine.

3. Lubricate the bearing cap bolts and tighten the bolts to the specified torque.

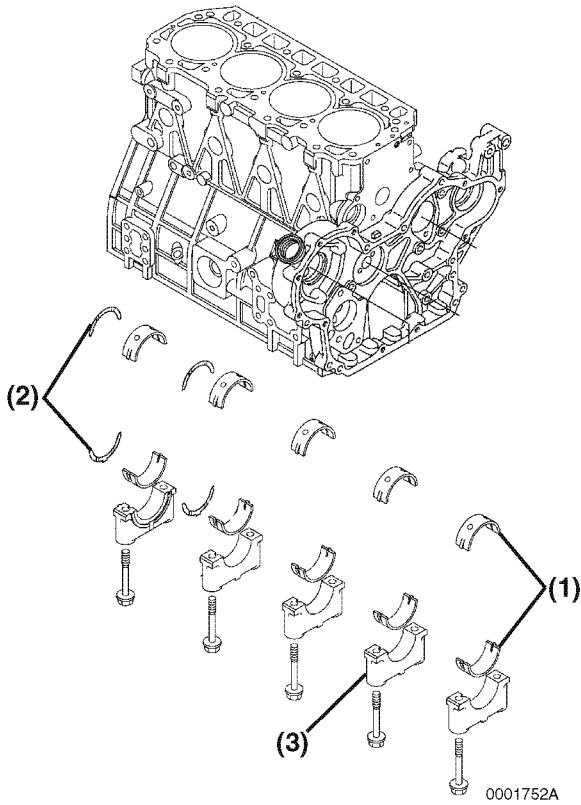

**Figure 6-76**

4. Install the rear oil seal housing.
  - If removed, install a new seal (Figure 6-77, (3)) in the rear oil seal housing.
  - Apply ThreeBond Liquid Gasket, Yanmar Part No. 977770-01212 to the mounting flange.
  - Align the seal housing (Figure 6-77, (2)) with the two dowel pins
  - Install and tighten the bolts to the specified torque.
5. Align the flywheel (Figure 6-77, (1)) to the crankshaft. Install the flywheel to the crankshaft bolts. Tighten the bolts to the specified torque.

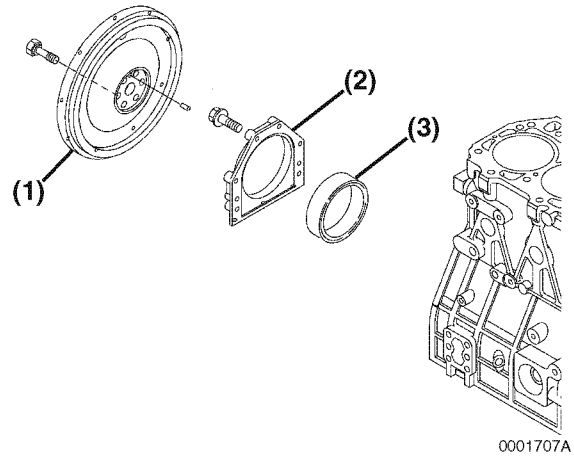

**Figure 6-77**

## Installation of Pistons

1. Lubricate No. 1 piston and piston rings.
2. Using the piston insertion tool (piston ring compressor), compress the piston rings on the No.1 piston.
3. Carefully install the piston into No.1 cylinder. Be sure the punched mark on the connecting rod is facing the fuel injector side and the embossed mark on the connecting rod is facing the flywheel.

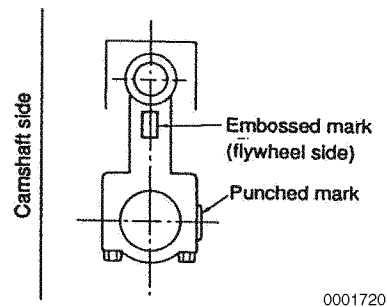

**Figure 6-78**

4. Install the connecting rod bearing halves (Figure 6-79, (1)) and connecting rod cap (Figure 6-79, (2)). Tighten the connecting rod bolts to the specified torque.

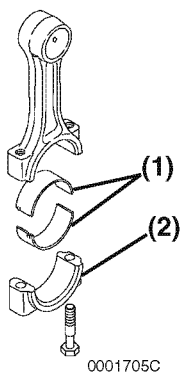

Figure 6-79

5. Install the remaining pistons in their respective cylinders.

### Installation of Camshaft

1. Lubricate the tappets. Install the tappets in their respective locations in the cylinder block. As when the camshaft was removed, the cylinder block must be in a position that allows gravity to keep the tappets in place and out of the way of the camshaft lobes when the camshaft is reinstalled.
2. Lubricate the camshaft (Figure 6-80, (2)). Slowly insert the camshaft through the front of the engine.
3. Position the camshaft thrust plate (Figure 6-80, (1)) to the gear case. Tighten the thrust plate bolt to the specified torque.

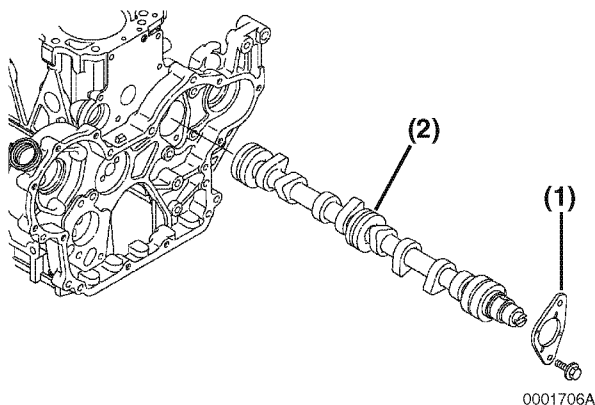

Figure 6-80

### Installation of Timing Gears

1. Lubricate the idler gear (Figure 6-81, (2)), bushing (Figure 6-80, (3)) and idler gear shaft (Figure 6-80, (1)). Install the idler gear and idler gear shaft. Be sure the oil hole in the bushing is facing toward the top of the engine. Tighten the idler gear bolts to the specified torque.

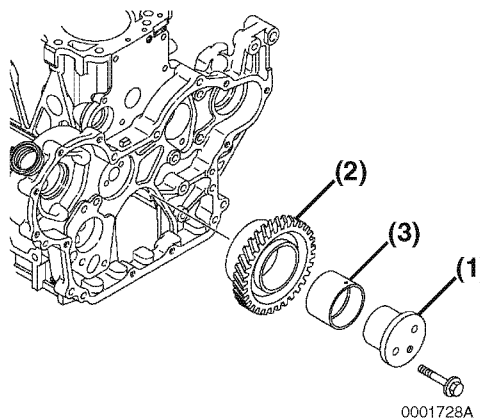

Figure 6-81

2. Align the timing gears as follows:
  - Install the crankshaft key in the crankshaft. Align mark "A" on the crankshaft gear with mark "A" on the idler gear and install the gear.
  - Align mark "B" on the fuel injection pump gear with mark "B" on the idler gear.
  - Install the camshaft key in the camshaft. Align mark "C" on the camshaft gear with mark "C" on the idler gear and install the gear.

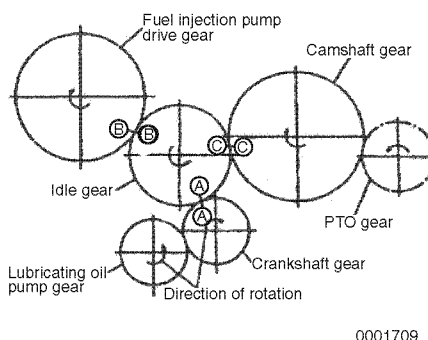

Figure 6-82

3. When all gears are properly aligned, tighten the retaining bolts to specified torque.

# ENGINE

## Installation of Gear Case Cover

1. Apply ThreeBond Liquid Gasket, Yanmar Part No. 977770-01212 to the outside diameter of a new oil seal (**Figure 6-84, (2)**). Use oil seal insertion tool to install the seal. Apply lithium grease to the lip of the seal.

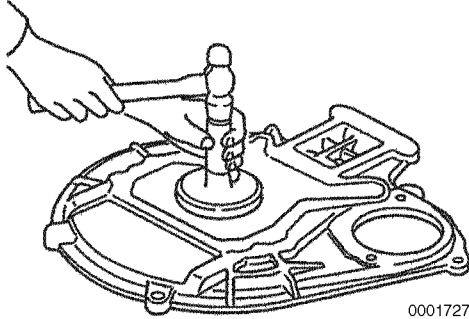

**Figure 6-83**

2. Apply ThreeBond Liquid Gasket, Yanmar Part No. 977770-01212 to the mounting area of the gear case cover (**Figure 6-84, (1)**).
3. Install the gear case cover bolts. Tighten the bolts to the specified torque.

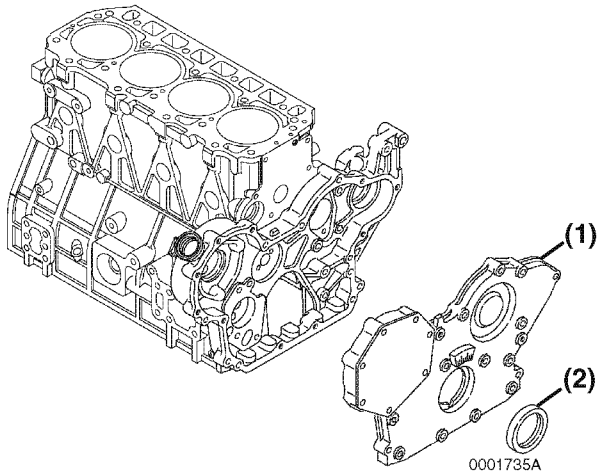
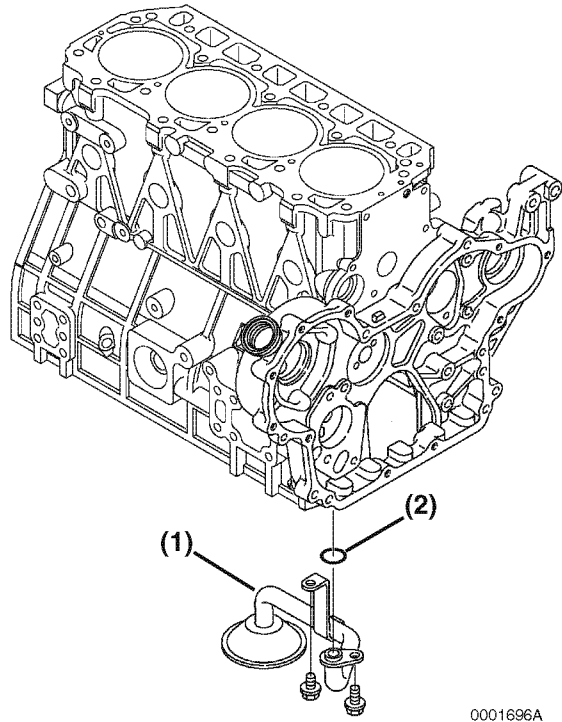

**Figure 6-84**

## Installation of Oil Sump Pump

1. Position a new O-ring (**Figure 6-85, (2)**) on the oil sump tube.
2. Position the oil sump tube (**Figure 6-85, (1)**) in the cylinder block.

3. Install the two oil sump tube bolts. Tighten the bolts to the specified torque.



**Figure 6-85**

## Installation of Oil Pan

1. Apply ThreeBond Liquid Gasket, Yanmar Part No. 977770-01212 to the mounting surface of the oil pan (**Figure 6-86, (1)**).
2. Install the bolts. Tighten the bolts to the specified torque.

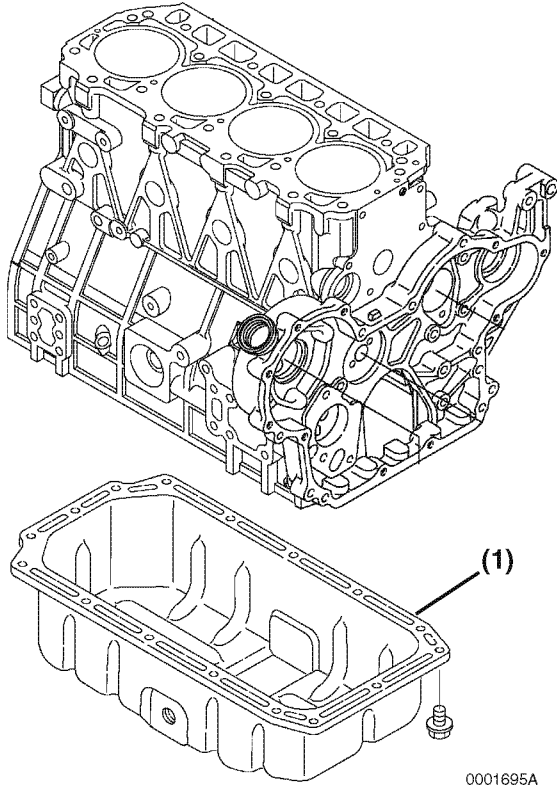

Figure 6-86

**This Page Intentionally Left Blank**



## Section 7

# FUEL SYSTEM

---

### Table of Contents

	Page
Measuring Instruments.....	7-3
Fuel System Special Torque Chart .....	7-3
Fuel System Components .....	7-4
Fuel System Diagram.....	7-5
Structure and Operation of Fuel Injection Pump .....	7-6
Overview.....	7-7
Plunger Operation .....	7-10
Process.....	7-11
Reverse Rotation Prevention Mechanism .....	7-13
Fuel Injection Volume Adjustment Mechanism.....	7-13
Delivery Valve Assembly .....	7-14
Delivery Valve Holder with Damping Valve .....	7-14
All -Speed Governor.....	7-15
At Start of Engine .....	7-17
During Idling .....	7-18
At Full-Load Maximum Speed Control.....	7-19
At No-Load Maximum Speed Control.....	7-20
Full-Load Position Adjustment Mechanism .....	7-21
Structure and Operation of Timer.....	7-22
Standard Type Automatic Timer.....	7-22
Magnetic Valve (Stop Solenoid) .....	7-23
Cold Start Device (CSD).....	7-24
Before You Begin Servicing .....	7-27
Removal of Fuel Injection Pump .....	7-28

## FUEL SYSTEM

---

Installation of the Fuel Injection Pump .....	7-31
Checking / Adjustment of Fuel Injection Timing .....	7-33
Servicing the Fuel Injectors .....	7-35
Removal of the Fuel Injectors.....	7-35
Inspection and Testing of the Fuel Injectors.....	7-36
Judgement Criteria on Atomization Condition .....	7-38
Installation of Fuel Injectors.....	7-39

## FUEL SYSTEM SPECIAL TORQUE CHART

Component	Tightening Torque	Lubricating Oil Application (Thread Portion and Seat Surface)	Reference Page
Fuel Injector	29.4 ft·lbs (39.2 N·m, 4 kgf·m)	Not Applied	<i>See Installation of Fuel Injectors on page 7-39</i>
Fuel Pump Drive Gear Nut	43.5 - 51.0 ft·lbs (59 - 69 N·m, 6.0 - 7.0 kgf·m)	Not Applied	<i>See Installation of the Fuel Injection Pump on page 7-31</i>

## MEASURING INSTRUMENTS

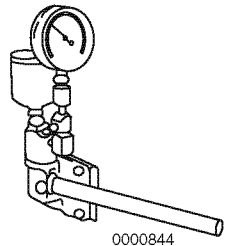
1	Fuel Injector Tester	For measuring injection spray pattern of fuel injection nozzle and injection pressure	 <p style="text-align: right; font-size: small;">0000844</p>
---	----------------------	---	--

# FUEL SYSTEM

This section of the *Service Manual* describes the theory of operation of the fuel injection pump, the procedures necessary to remove and install the fuel injection pump and the procedures for inspecting and testing the fuel injectors.

## FUEL SYSTEM COMPONENTS

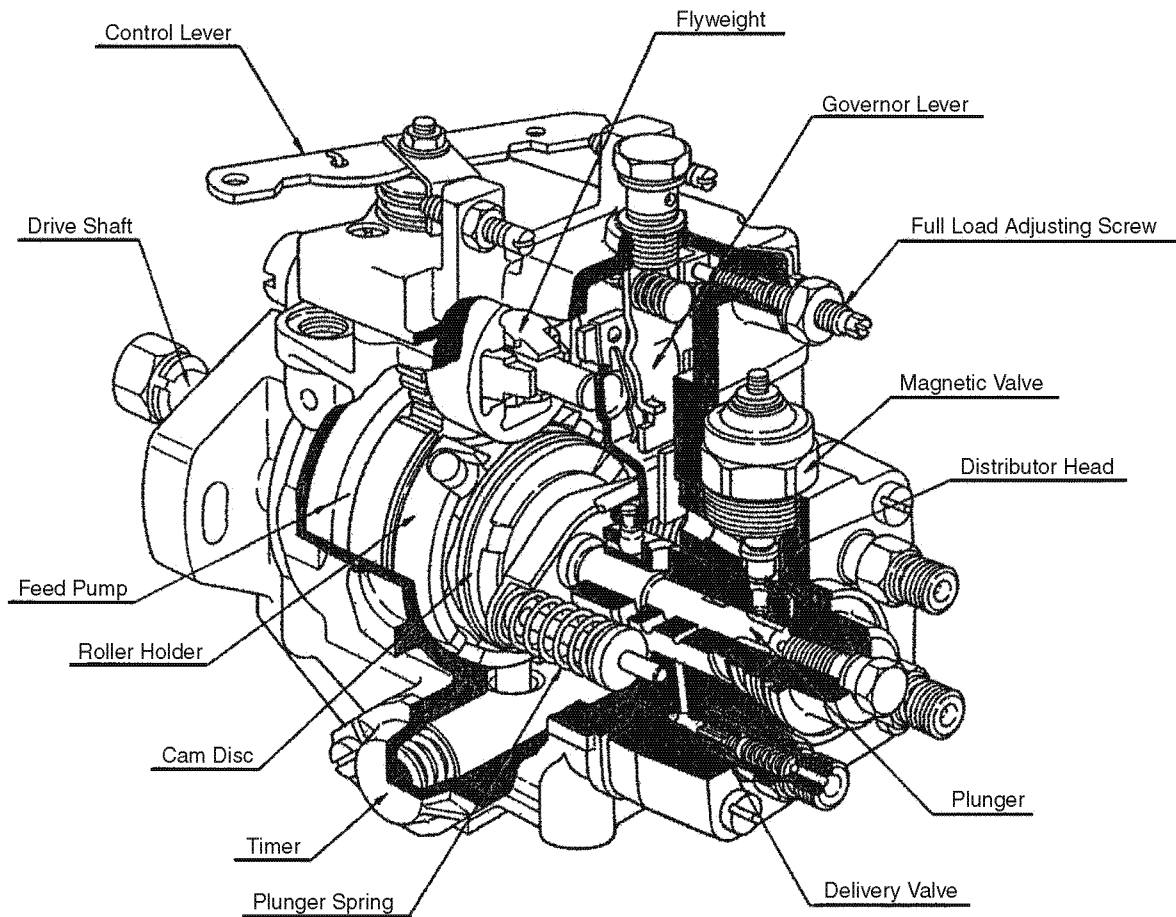

0001629

**Figure 7-1**

FUEL SYSTEM DIAGRAM

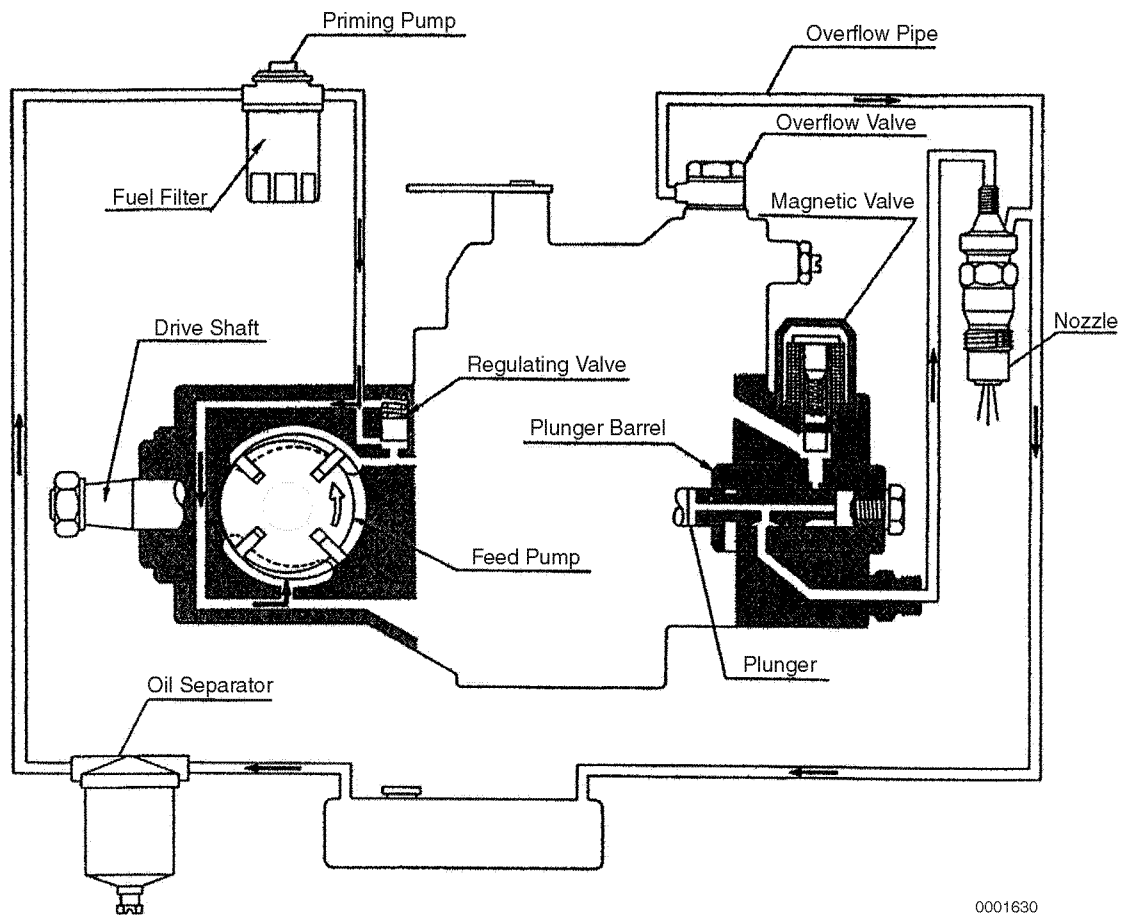

0001630

Figure 7-2

Fuel is fed from the fuel tank into the fuel inlet of the injection pump by the feed pump built into the injection pump via the oil separator and fuel filter.

A filter is installed for fuel filtration. A filter with an oil separator for water separation is also provided at the bottom.

Pressure is applied to feed fuel into the fuel inlet by the feed pump in order to feed fuel into the injection pump chamber.

Although the fuel pressure in the pump chamber is proportional to the pump revolution, excessive fuel is returned to the suction system by the regulating valve when the pressure exceeds the specified value. The fuel is then sent to the plunger via the fuel path in the distributor head. The plunger applies high pressure to the fuel to feed it to the nozzle and nozzle holder through the injection pipe.

The overflow valve above the injection pump functions to maintain constant fuel temperature in the pump chamber and return excessive fuel to the fuel tank.

STRUCTURE AND OPERATION OF FUEL INJECTION PUMP

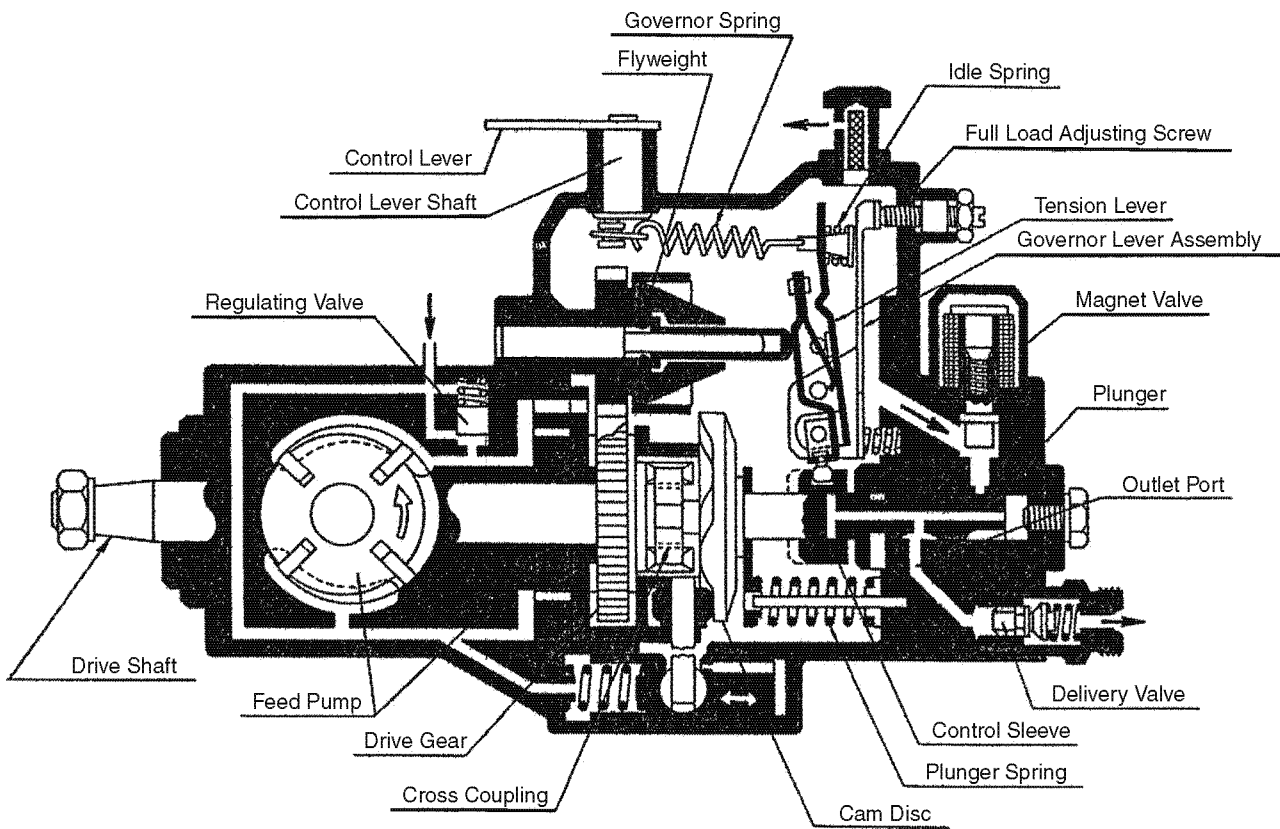

0001631

Figure 7-3

Overview

Pump

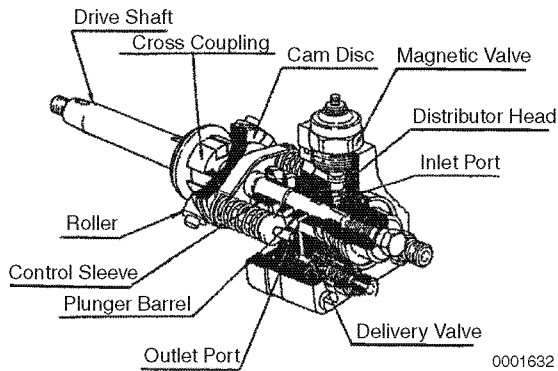

Figure 7-4

The drive shaft directly receives the engine revolution via the timing belt (or gear) and transfers it to the cam disc via the cross coupling. Since the dowel pin of the cam disc is integrated with the plunger and fixed in the groove in the plunger collar, the plunger operates at the same speed as the cam disc.

The cam disc has a face cam and conducts reciprocating operations by the specified cam lift on the roller in the roller holder assembly.

On the outside of the plunger are two plunger springs having the settling force to return the plunger lifted by the cam disc during the lowering process. Thus, the plunger revolves by means of the drive shaft and the reciprocates by means of the cam disc. When the fuel fed under high pressure by the plunger reaches the outlet port, the delivery valve opens to inject it into the engine combustion chamber via the nozzle and nozzle holder.

Governor

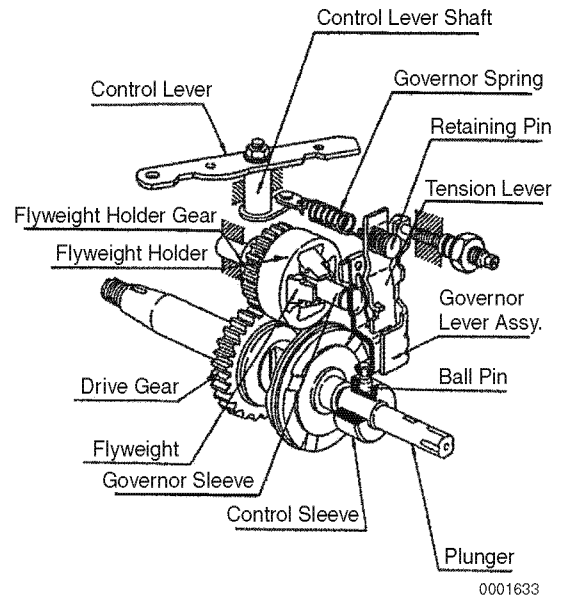
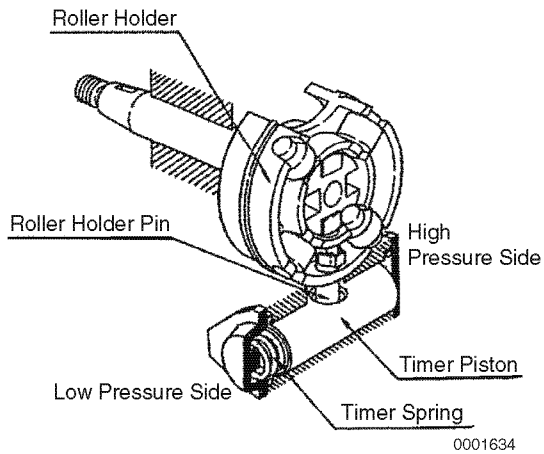

Figure 7-5

The governor is located above the inspection pump chamber and mainly consists of a flyweight holder and governor lever assembly. The flyweight holder holds four flyweights and governor sleeves, and is supported by the governor shaft.

The drive gear engages with the flyweight holder gear to increase the revolutions of the drive shaft and to turn the flyweight holder assembly. The governor lever assembly is secured by the pivot bolt of the pump housing and the ball pin at the bottom of the assembly is inserted into the control sleeve which slides on the outer periphery of the plunger. The governor spring at the top of the assembly is connected to the tension lever by the retaining pin. The end of the governor spring is connected to the control lever via the control lever shaft. The control lever is linked to the acceleration pedal via the link to change the set force of the governor spring according to the inclined angle. The difference between the governor spring set force and the flyweight centrifugal force determines the moving distance of the control sleeve, thereby increasing or decreasing the fuel injection volume.

## Timer



**Figure 7-6**

At the bottom of the injection pump is the built-in timer. A timer spring having a set force is installed on the low pressure side of the timer piston. The fuel pressure in the pump chamber is directly applied to the other end (high pressure side) of the timer piston. The position of the timer piston changes according to the balance between the fuel pressure and the timer spring force to turn the roller holder via the roller holder pin. When the piston moves in the direction to compress the timer spring, the roller holder moves in the advance direction (counter-revolution direction) to early the injection timing. Thus, the timer controls the fuel injection timing according to the fuel pressure in the pump chamber.

## Feed Pump (Vane Type)

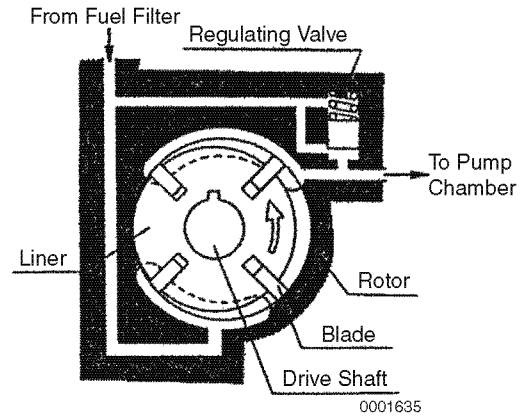

**Figure 7-7**

The feed pump functions to feed fuel from the fuel tank to the pump chamber.

The feed pump consists of the rotor, blade (vane) and liner. The rotor is driven by the drive shaft. The liner is located eccentrically to the center of the rotor and four blades (vanes) are located between the rotor and liner. When the rotor turns, the blades are pressed onto the liner inner wall by centrifugal force to change the capacity of the chambers according to the revolutions. When the capacity of a chamber increases, it draws fuel from the fuel tank.

When the capacity decreases, it feeds fuel into the pump chamber.



**Regulating Valve**

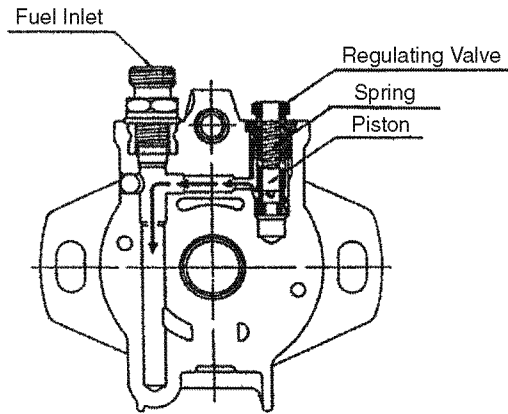

0001636

**Figure 7-8**

The regulating valve regulates the fuel feeding pressure of the feed pump so that the fuel pressure in the pump chamber is maintained within the specified pressure range.

When the injection pump revolutions increase to increase the fuel feeding pressure of the feed pump, the fuel compresses the regulating valve spring to lift the piston. The fuel is then returned to the suction side as shown by the arrow in the figure.

It is therefore possible to regulate the pump chamber pressure by changing the set force of the regulating valve spring.

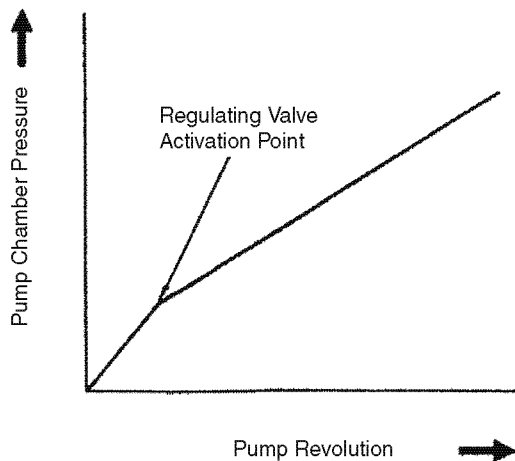

0001637

**Figure 7-9**

**Figure 7-9** shows typical relationships between pump revolutions and pump chamber pressure. The hydraulic timer directly uses the pump chamber pressure for controlling the injection timing.

## PLUNGER OPERATION

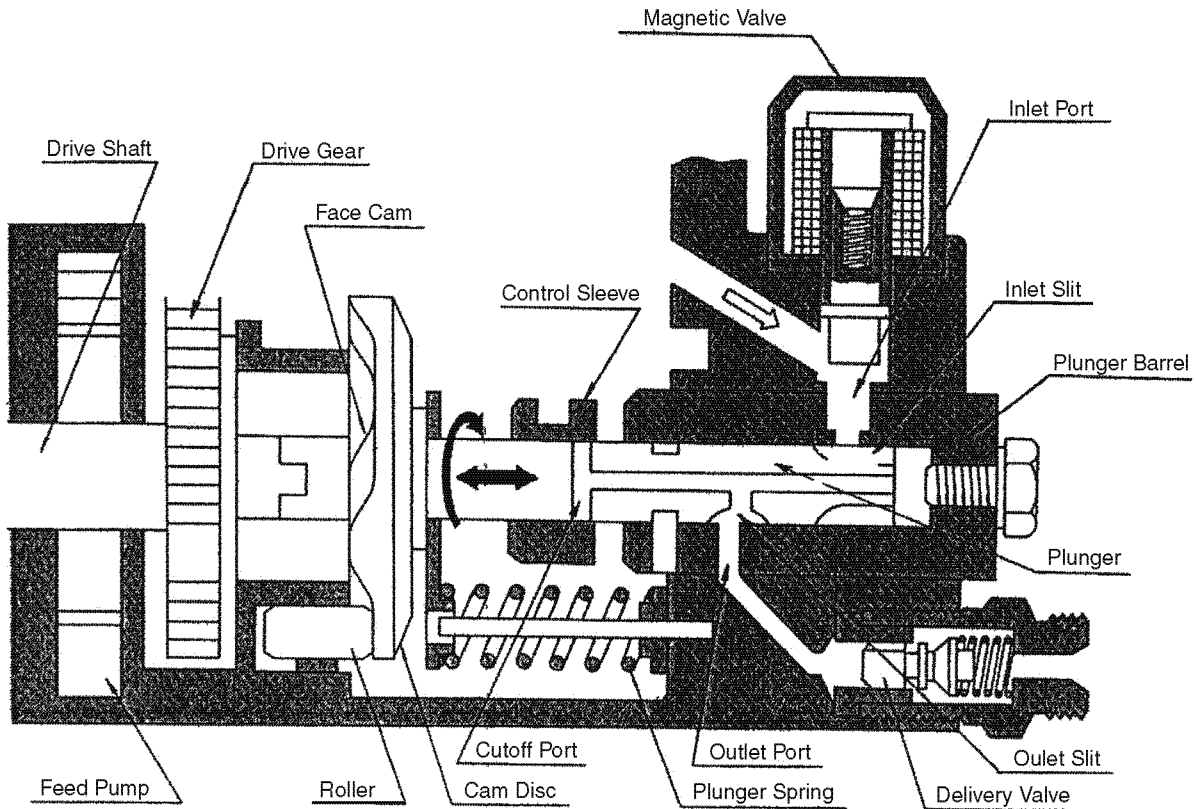

0001638

The drive shaft simultaneously drives the feed pump, cam disc and plunger. The plunger spring presses the plunger and cam disc onto the roller. When the cam disc turns by means of the drive shaft, the face cam moves on the roller to activate the plunger's reciprocating operation. When the inlet port of the plunger barrel being pressed into the distributor head and the inlet slit of the plunger overlap, the plunger draws fuel and applies pressure to it.

When the outlet port of the plunger barrel and the outlet slit of the plunger align, the high-pressure fuel opens the delivery valve to be injected into the engine combustion chamber via the nozzle. When the cutoff port reaches the control sleeve, pressure feeding from the plunger is terminated.

Process

Injection Process

Suction Process

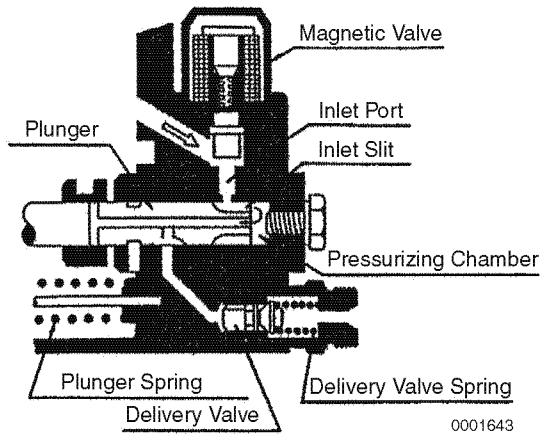

Figure 7-10

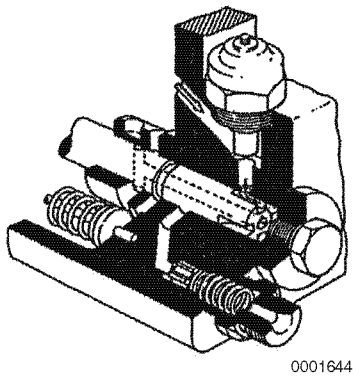

Figure 7-11

When the inlet port of the plunger barrel overlaps the inlet slit of the plunger during the lowering process of the plunger, the fuel in the pump chamber is drawn into the plunger.

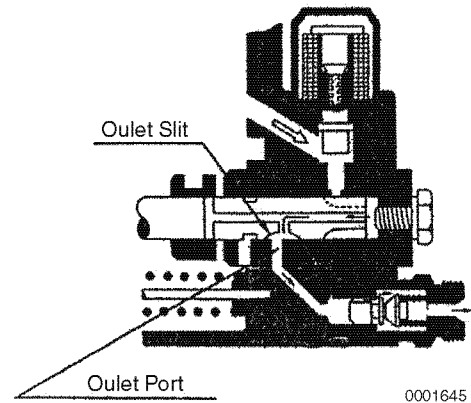

Figure 7-12

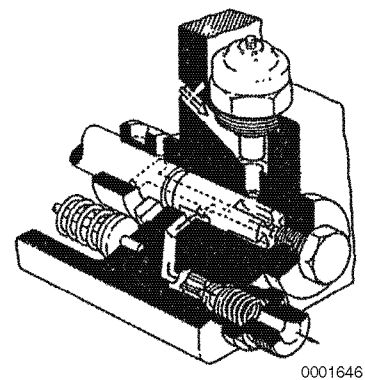
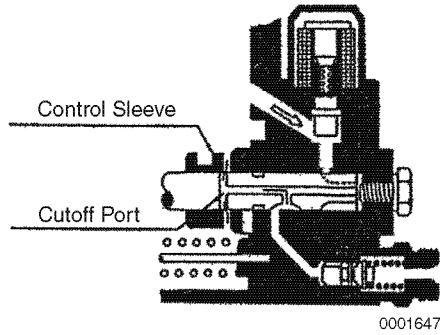

Figure 7-13

The plunger begins rotating at the same time the lifting process of the cam disc begins. When the inlet port of the plunger barrel is covered by the plunger, pressure feeding of fuel is initiated. At the same time, the highly pressurized fuel presses up the delivery valve when the outlet slit of the plunger meets the outlet port of the plunger barrel. The fuel is then injected into the engine combustion chamber via the nozzle and nozzle holder.

## End of Injection



**Figure 7-14**

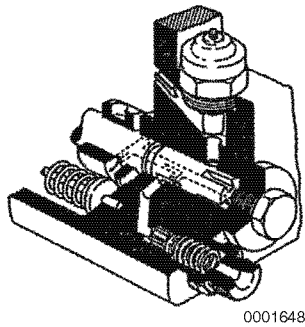

**Figure 7-15**

When the plunger is further lifted up by the cam disc until the cutoff port of the plunger just overruns the control sleeve, the high-pressure fuel in the plunger high-pressure chamber returns to the pump chamber through the cutoff port. As a result, the fuel pressure in the plunger becomes lower than the set force of the delivery valve spring, so, the delivery valve closes to terminate pressure feeding of fuel.

## Uniform Pressure Process

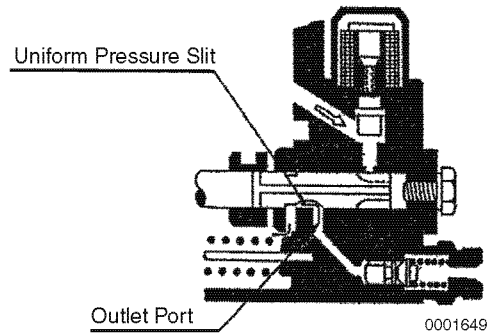

**Figure 7-16**

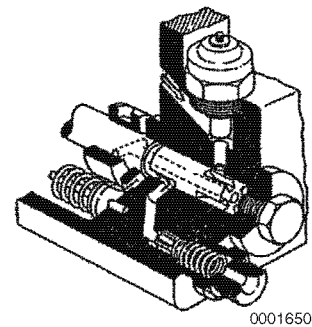
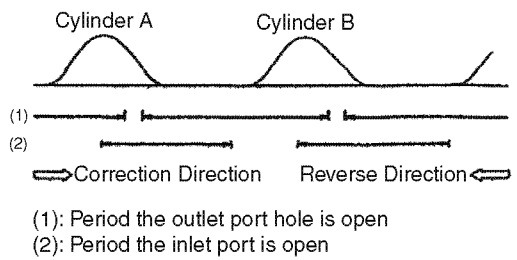

**Figure 7-17**

When the plunger turns a further 180° after the end of fuel injection, the uniform pressure slit of the plunger meets the outlet port of the plunger barrel. As a result, the pump chamber is connected to the outlet port, thereby making the pressure in the chamber and outlet port equal. After the uniform pressure process, the pressure in the outlet port becomes uniform, ensuring stable fuel injection.

The suction process through the uniform pressure process are carried out for each cylinder during every injection cycle.

## Reverse Rotation Prevention Mechanism

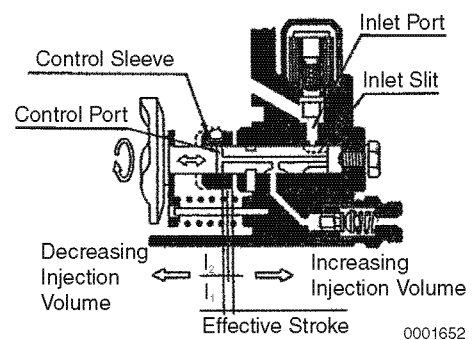

**Figure 7-18**

While the plunger is rotating in the correct direction, the fuel is sufficiently drawn into the plunger since the inlet port of the plunger barrel opens during the plunger lowering process. The inlet port closes during the lifting process to inject the fuel.

On the contrary, the inlet port of the plunger barrel does not close during the plunger lifting process if the engine rotates in the reverse direction. So, the fuel is not pressurized, resulting in non-injection state.

## Fuel Injection Volume Adjustment Mechanism



**Figure 7-19**

The fuel injection volume is increased or decreased by changing the control sleeve position, resulting in change of the effective stroke. The effective stroke represents the plunger's stroke from the time the inlet port and inlet slit close until the cutoff port overruns the control sleeve, which is proportional to the fuel injection volume. When the control sleeve moves to the left, the effective stroke ( $l_2$ ) decreases. When the control sleeve moves in the opposite direction, or to the right, the effective stroke ( $l_1$ ) increases to increase the fuel injection volume. The control sleeve position is determined according to the governor control.

## Delivery Valve Assembly

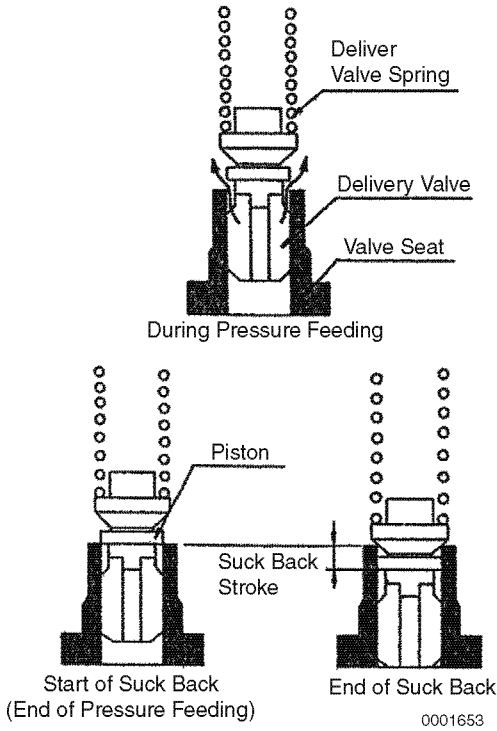

**Figure 7-20**

The delivery valve assembly consists of the delivery valve and valve seat.

When the pressure of the high-pressure fuel being fed from the plunger exceeds the force of the delivery valve spring, the delivery valve opens to feed the high-pressure fuel to the nozzle and nozzle holder via the injection pipe. After injection, a certain degree of remaining pressure exists in the injection pipe ready for the next injection. The delivery valve prevents the fuel remaining in the injection pipe from returning to the plunger.

If the remaining pressure is excessively high, cutoff of the fuel may be adversely affected.

The delivery valve also functions to improve fuel cutoff of the nozzle by drawing back the fuel in the pipe by the amount equal to the suck-back stroke of the piston.

## Delivery Valve Holder with Damping Valve

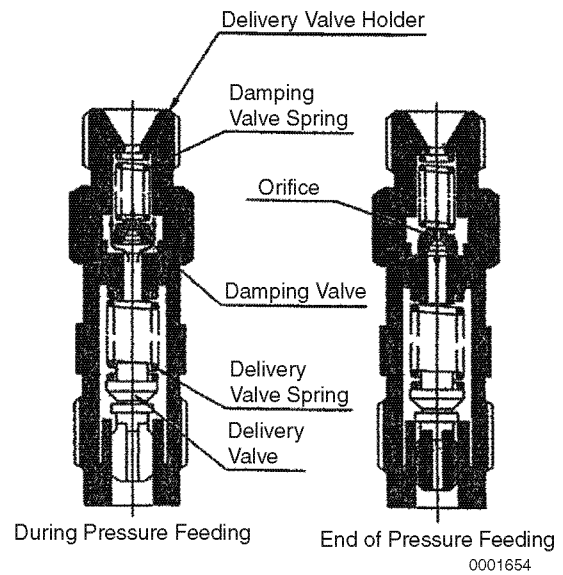

**Figure 7-21**

The delivery valve holder with damping valve functions to prevent cavitation erosion in the pipe at high speed, unstable fuel injection and secondary injection.

When high-pressure fuel is fed from the plunger, it is mainly sent to the nozzle through the outer periphery of the damping valve since the damping valve also opens at the same time as the delivery valve upon completion of each injection cycle.

So, the only fuel path left is the small orifice of the damping valve. This permits the slow closing of the delivery valve. Thus, rapid pressure decrease in the pipe is prevented and transfer of the reflection wave in the pipe suppressed to ensure stable injection.

Note: Cavitation represents the phenomenon where bubbles are generated in the pipe when the pressure in the pipe drops. Cavitation erosion means erosion of the pipe inner wall as a result of cavitation.

# ALL -SPEED GOVERNOR

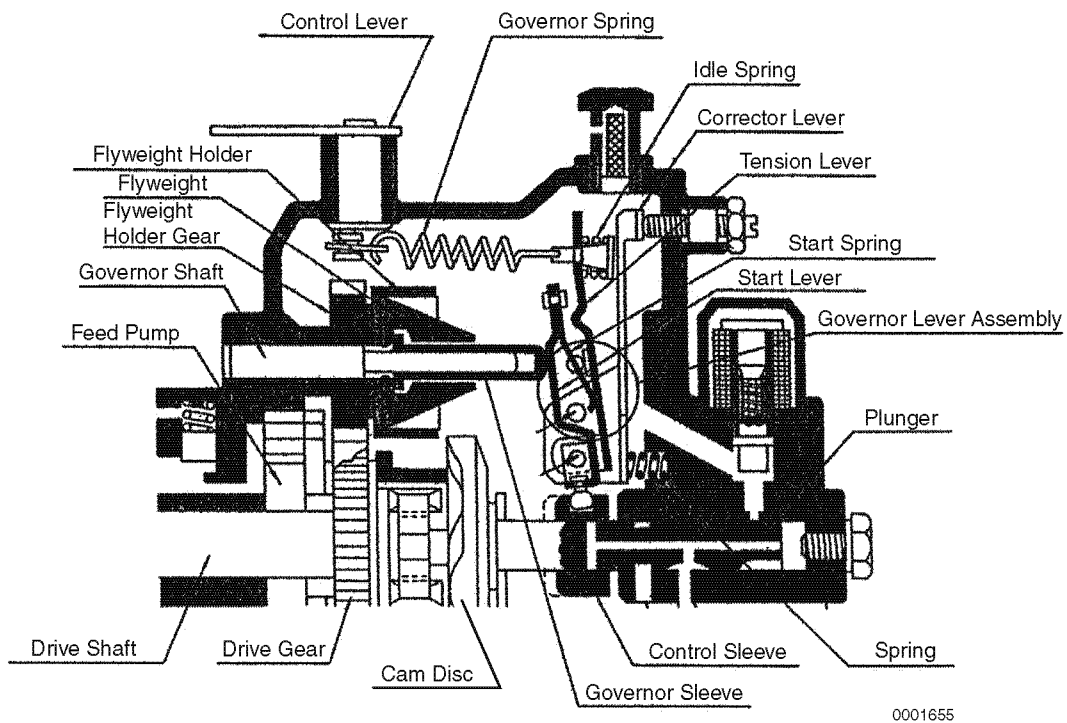

Figure 7-22

Figure 7-22 shows the composition of the all-speed governor.

Revolution of the shaft is transferred to the flyweight holder acceleration gear via the drive gear to turn the flyweight holder.

The flyweight holder is supported by the governor shaft. There are four flyweights in the holder which are installed in such a way that they open outwardly by means of centrifugal force.

The flyweight movement presses the governor sleeve and presses the governor lever assembly to the right. The governor lever assembly mainly consists of the corrector lever, tension lever and start lever. Corrector lever fulcrum  $M_1$  is fixed by the pivot bolt of the pump housing. Furthermore, the corrector lever cannot move since it is pressed both by the spring at the bottom and the full load adjusting screw at the top. The tension and start levers move around shaft  $M_2$  as the fulcrum fixed on the corrector lever.

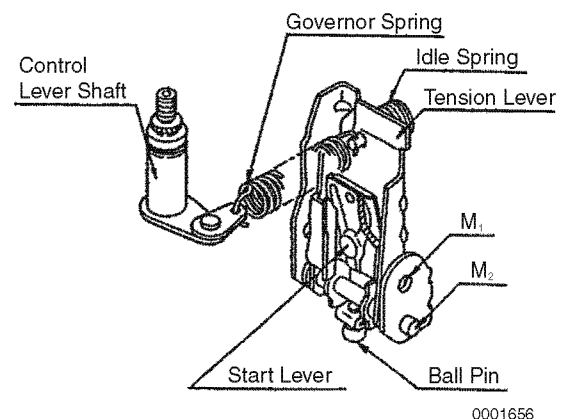

Figure 7-23

The start spring presses the start lever into the governor sleeve at engine start. The start lever turns counterclockwise around fulcrum  $M_2$  to move the control sleeve to the start offset position.

## FUEL SYSTEM

The start and tension levers contact each other and move together during engine operation. Above the tension lever is the governor spring which is connected to the control lever. Movement of the control lever is capable of changing the set force of the governor spring. On the upper back of the tension lever is the idle spring.

The governor is controlled at all speeds by means of the start, governor and idle springs.

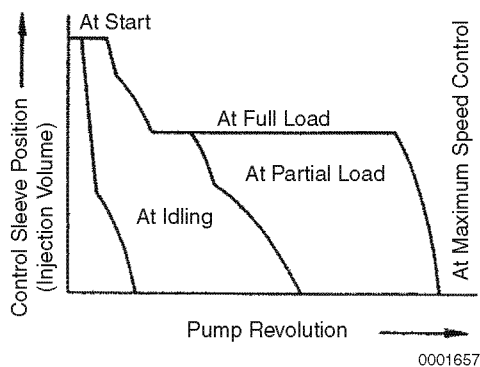

**Figure 7-24**

**Figure 7-24** shows the typical injection volume control characteristics of the all-speed governor.



## At Start of Engine

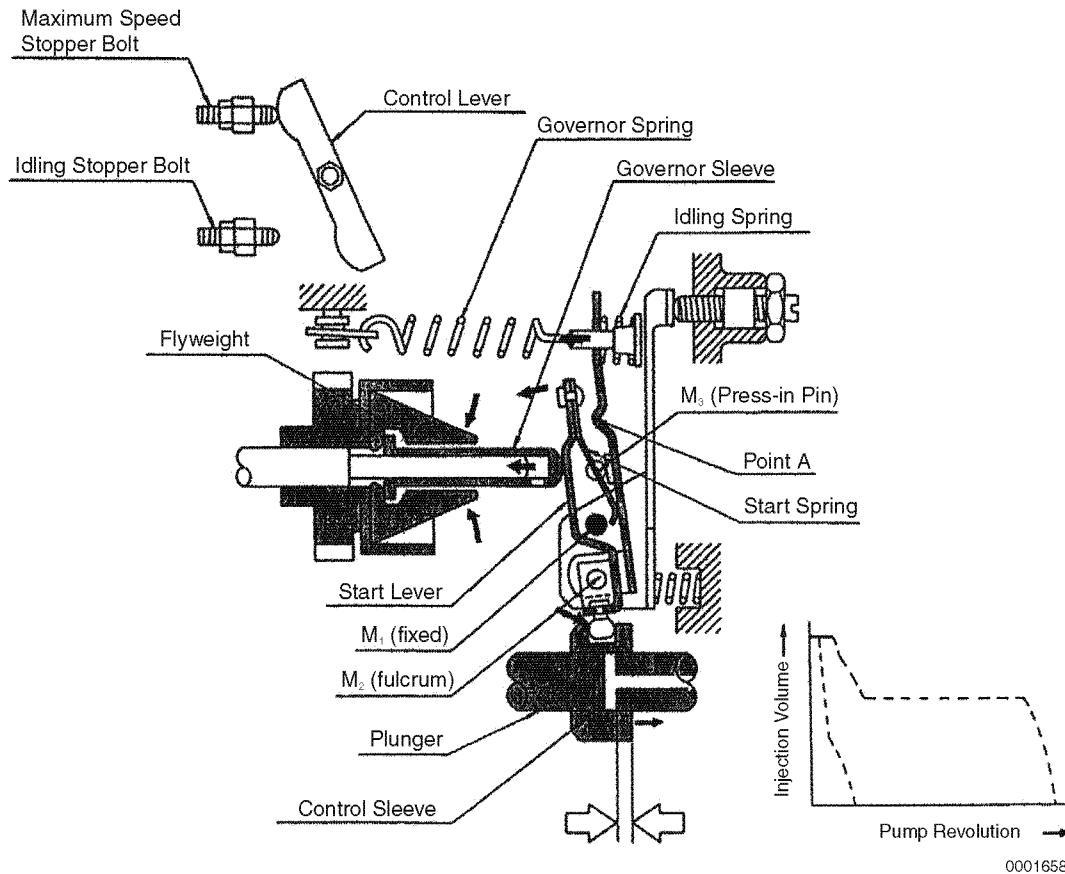

Figure 7-25

It is necessary to increase the injection volume in order to improve the starting characteristics at engine start.

When the accelerator pedal is pressed while the engine is stopped, the tension lever is pulled until it comes into contact with press-in pin M<sub>3</sub> by governor spring force.

At the same time, the start lever is released from the tension lever by the start spring force to press the governor sleeve to the left. The flyweight then closes completely and the start lever moves the control sleeve to the start increasing position (to the right) with M<sub>2</sub> being the fulcrum.

Thus, the engine can be started easily by lightly pressing down on the accelerator pedal.

## During Idling

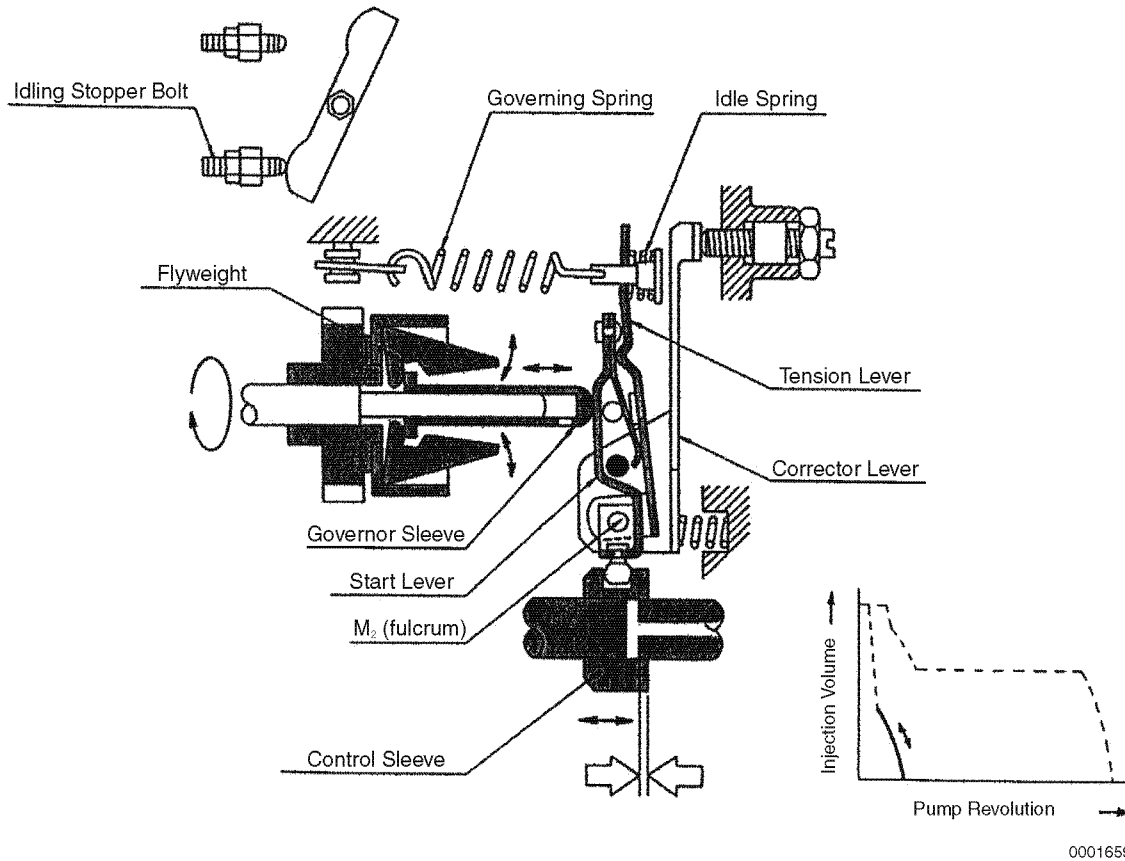
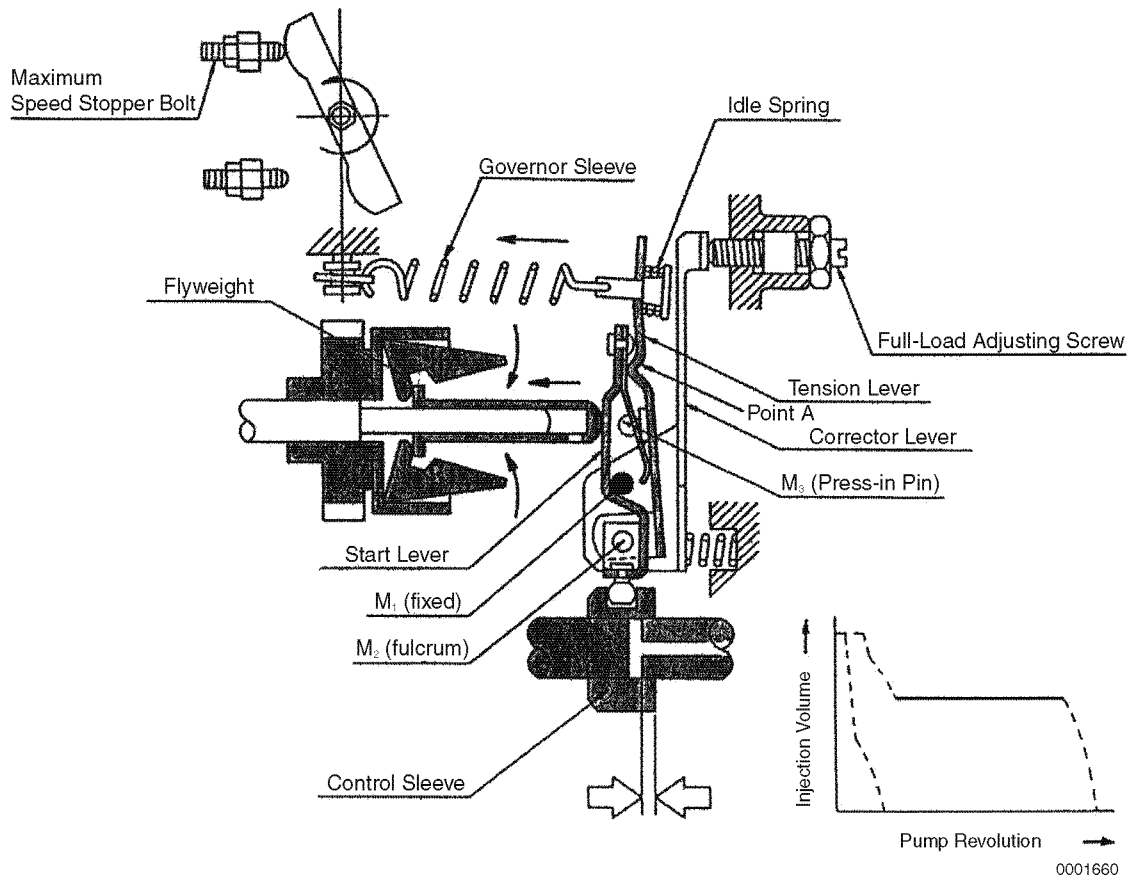

**Figure 7-26**

When the engine starts and the accelerator pedal is released, the control lever returns to the idle position and the tension of the governor spring becomes zero. Therefore, the flyweight opens outwardly even at low revolutions to move the governor sleeve to the right.

This makes the start lever turn clockwise with M<sub>2</sub> being the fulcrum to move the control sleeve in the direction to reduce the fuel volume. The governor sleeve stops at a point where the flyweight centrifugal and idle spring force are balanced to ensure stable idling.

## At Full-Load Maximum Speed Control



**Figure 7-27**

When the accelerator pedal is pressed down all the way and the control lever comes into contact with the maximum speed stopper bolt, the tension of the governor spring becomes maximum.

At this time, the tension lever is fixed at the position where it contacts pin  $M_3$  being pressed into the pump housing. The idle spring is completely compressed to connect the start lever and the tension lever at point A, thereby holding the control sleeve at the full-load position. At this time, the flyweight is pressed by the governor sleeve and is in the completely closed state.

# FUEL SYSTEM

## At No-Load Maximum Speed Control

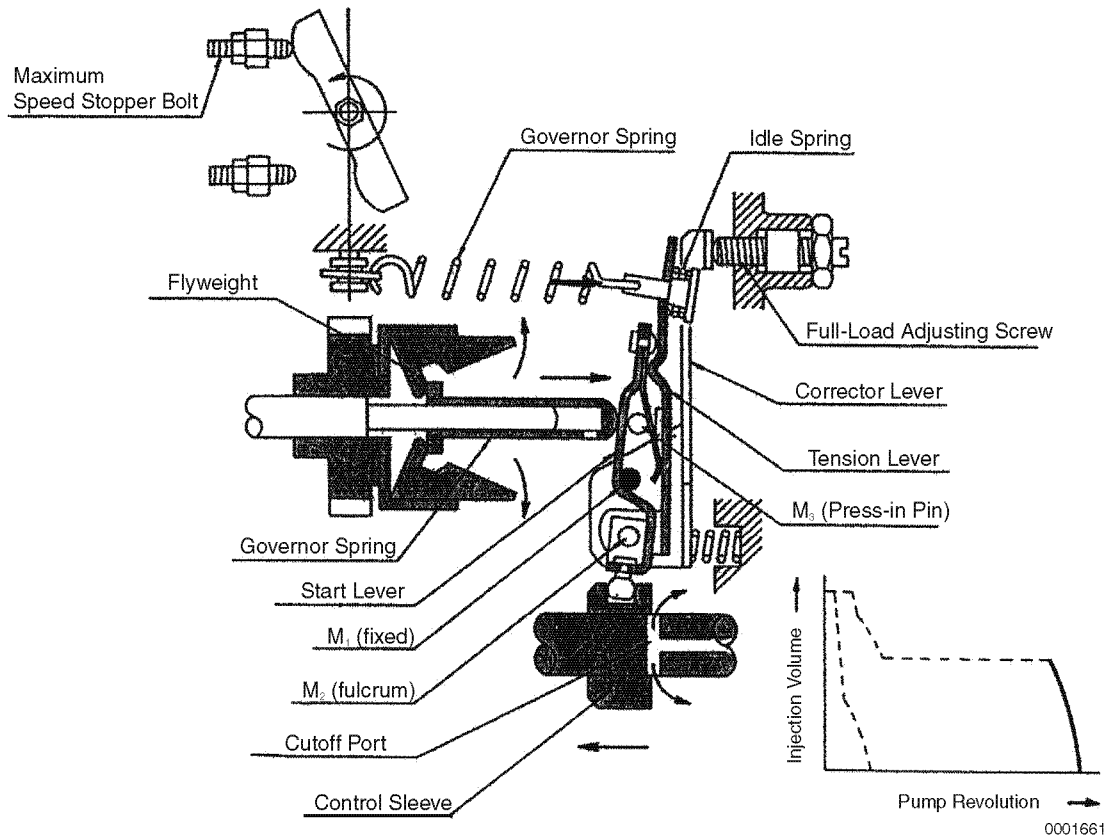
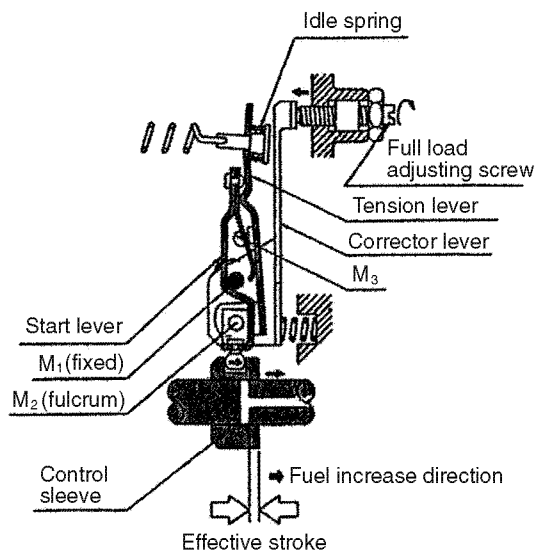

Figure 7-28

When the engine revolutions increase and the flyweight centrifugal force exceeds the governor spring set force, the governor sleeve moves to make the governor lever assembly turn clockwise with fulcrum M<sub>2</sub>. As a result, the control sleeve moves in the direction of no-injection (to the left) for controlling speed so as not to exceed the full-load maximum speed.

When the accelerator pedal is not pressed down fully, the set force of the governor spring changes accordingly in order to achieve governor control based on the governor spring set force during partial load operation.

## Full-Load Position Adjustment Mechanism



0001662

**Figure 7-29**

The full-load position is determined by the amount the full-load adjusting screw is driven. When the screw is driven, the corrector lever turns counterclockwise with  $M_1$  being the fulcrum to move the control sleeve to the fuel increase direction.

When the screw is loosened, the control sleeve moves to the fuel decrease direction.

**STRUCTURE AND OPERATION OF TIMER**

The ignition period which occurs in the combustion process of a diesel engine tends to increase as the speed becomes higher.

Consequently, the timer is installed under the injection pump in order to correct the ignition delay period by shortening the injection timing of the injection pump.

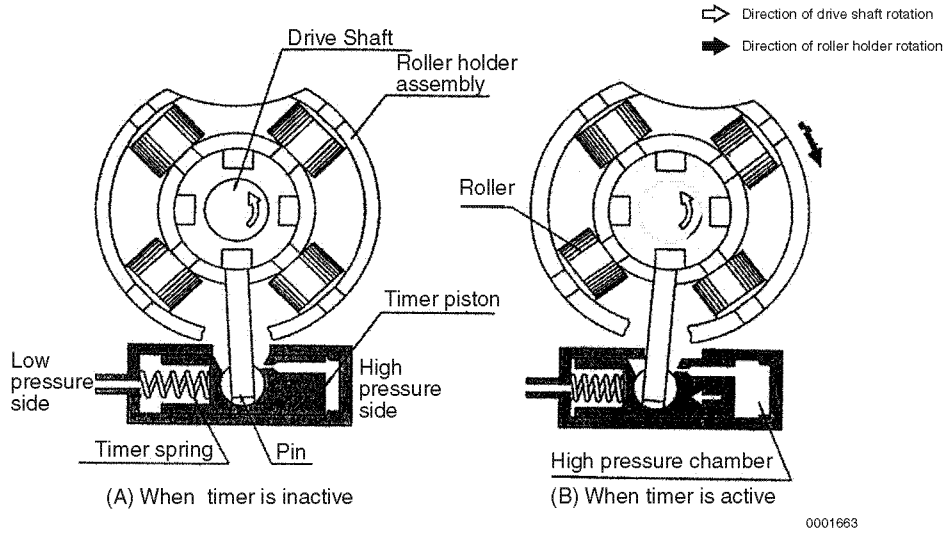

**Figure 7-30**

**Standard Type Automatic Timer**

As shown in **Figure 7-30**, the inside of the timer housing is separated into low and high pressure sides, the latter directly receiving the pump chamber pressure. A timer spring having a set force is installed in the low pressure side. The timer piston slides horizontally based on the balance between the spring force and changes in the pump chamber pressure. The movement of the timer piston turns the roller holder assembly via the pin.

When pump revolutions increase and the pump chamber pressure exceeds the set force of the timer spring, the timer piston moves in the direction to compress the spring ([B] in **Figure 7-30**). This turns the roller holder assembly in the reverse direction of pump revolution via the pin. This causes the crest of the cam disc to quickly approach the roller position of the roller holder, to advance the injection timing. On the contrary, when pump revolutions decrease and the timer spring force exceeds the pump chamber pressure, the timer piston moves in the direction to delay the timing.

## Magnetic Valve (Stop Solenoid)

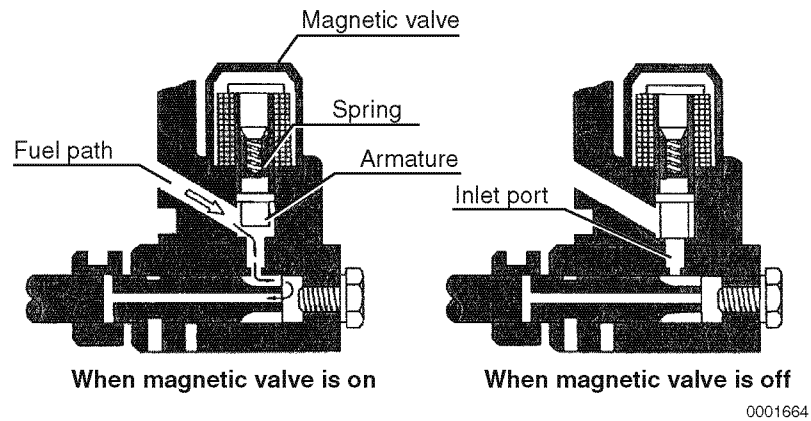

**Figure 7-31**

The magnetic valve (stop solenoid) turns on or off as the ignition switch of the vehicle is operated to open or close the fuel path connected to the inlet port of the plunger barrel.

When the ignition switch is turned on, power is supplied to the magnetic valve to lift the armature, thus opening the fuel path.

On the contrary, when the ignition switch is turned off, the armature is powered by the force of the spring installed in the armature to close the fuel path. As a result, no fuel is fed to the plunger, stopping the engine immediately.

## Cold Start Device (CSD)

(Standard for Tertiary Corresponding Machines, Optional for Secondary Corresponding Machines)

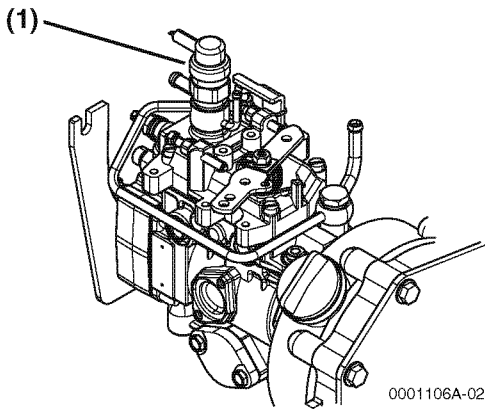

**Figure 7-32**

### 1. Cold Start Device

### Necessity of CSD

In order to correspond with the incoming regulation, the fuel injection timing of 4TNE98 is delayed.

By delaying the fuel injection timing, starting at cold-start is deteriorated.

As its countermeasure, CSD is installed on the timing regulation corresponding engine to detect the engine coolant temperature to advance the injection timing when the coolant temperature is low, and return the injection timing to normal when the coolant temperature is over the threshold value.

### • Summary

CSD is an equipment which controls the injection timing of injection pump by turning ON and OFF the switch while the engine is running. CSD is comparable to actuator part, and the separate switch is installed on the engine side (coolant temperature sensor) for turning it ON and OFF.

### • Structure

As shown in **Figure 7-33**, CSD is structured by the magnet, spring, and piston. When the magnet is in the ON position, the piston is pulled to the counterclockwise direction by the magnet force. Also, the spring inside piston has a force to go to the clockwise direction to return the piston to its original position. There are 2 holes in the piston, and when the magnet is in the OFF position, these holes are matched with the holes in the housing, so that fuel oil inside the pump room can flee to the fuel inlet (the low-pressure side).

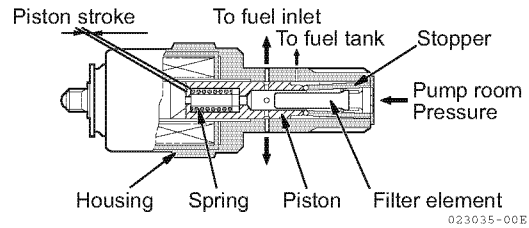

**Figure 7-33**

### • Actuation

As a switch to turn ON and OFF the CSD, the coolant temperature sensor is used. At start, when the coolant temperature is below the setting temperature, the thermo switch is turned ON to turn ON the CSD and move it to the advance direction of the injection timing by rapidly increasing the pump room pressure. On the other hand, when the coolant temperature is above the setting temperature, the thermo switch is turned OFF, and the CSD is not actuated and becomes the normal timer advance characteristics.

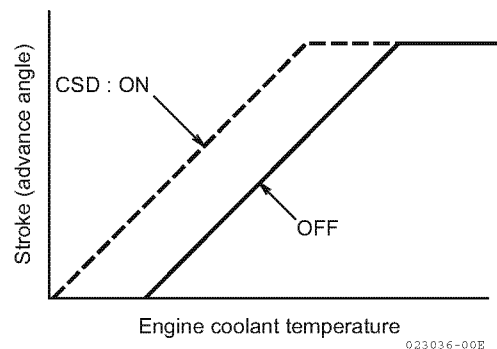

**Figure 7-34**



### CSD Coupler Shape

As CSD coupler shape is 7319-3311-30 (Yazaki Parts No.), arrange 7318-3311-30 (Yazaki Parts No.) for the automobile body side harness coupler.

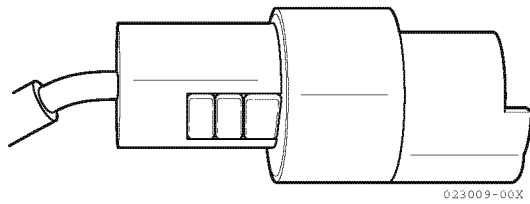

Figure 7-35

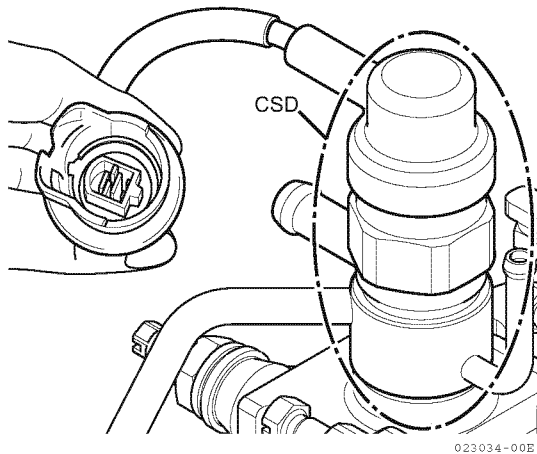

Figure 7-36

### Coolant Temperature Sensor

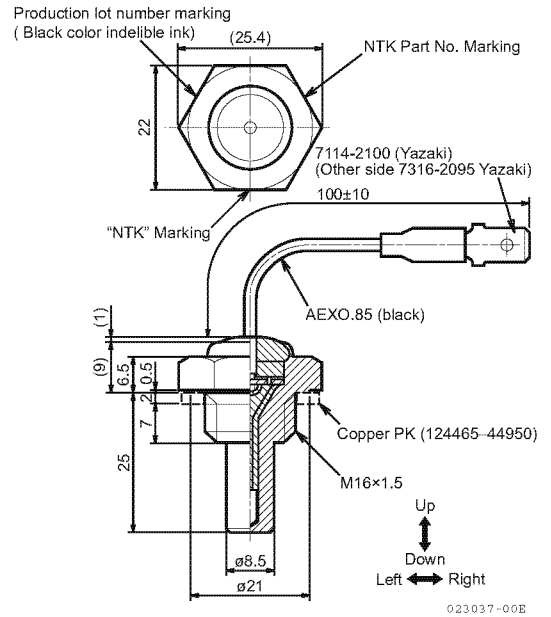

Figure 7-37

### Controller External View (Optional)

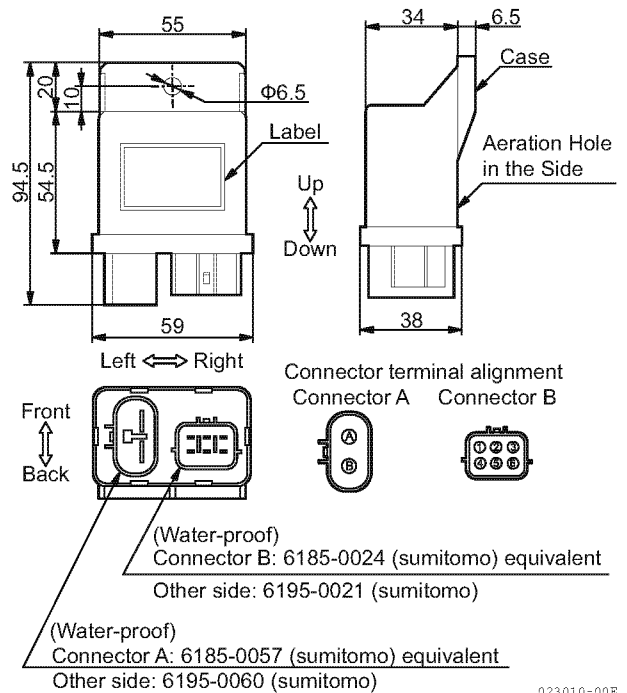
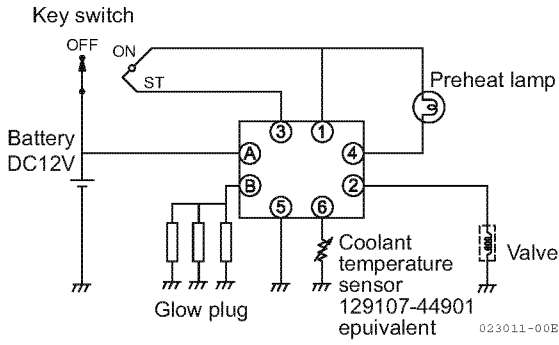

Figure 7-38

## Connecting Diagram



**Figure 7-39**

## Actuation Chart

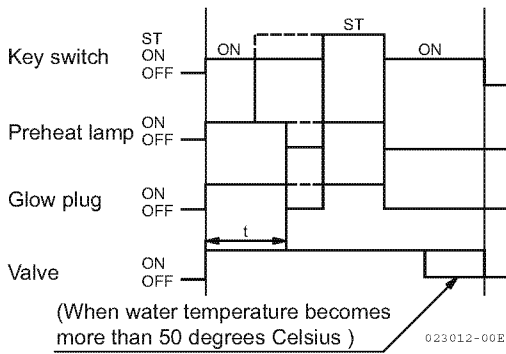

**Figure 7-40**

## Function

1. Preheat Lamp
  - When turned to the key ON position from the key OFF position, the preheat lamp is lit for a given length of time
  - While in the key START position, the preheat lamp is lit
2. Glow Relay
  - When turned to the key ON position from the key OFF position, the glow relay is turned ON for a given length of time (glow power distribution)
  - While in the key START position, the glow relay is turned ON (glow power distribution)
3. CSD
  - When turned to the key ON position while the coolant temperature is below the setting temperature, the CSD is turned ON
  - However, when the coolant temperature becomes above the separate setting temperature, the CSD is turned OFF

## Relay Characteristics

	Item	Standard	Remarks
Char.	Contact Voltage Descent	0.2V or Below	40A, 30 Seconds Later
	Insulation Resistance	Above 1M $\Omega$	DC500V MG

## BEFORE YOU BEGIN SERVICING

### ⚠ WARNING

#### SEVER HAZARD!



- Stop the engine before you begin to service it.
- NEVER leave the key in the key switch when you are servicing the engine. Someone may accidentally start the engine and not realize you are servicing it. This could result in a serious injury.
- If you must service the engine while it is operating, remove all jewelry, tie back long hair, and keep your hands, other body parts and clothing away from moving / rotating parts.
- Failure to comply could result in death or serious injury.

### ⚠ WARNING

#### EXPOSURE HAZARD!

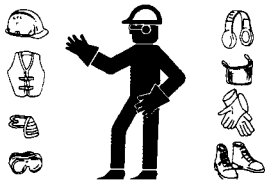

- Always read and follow safety related precautions found on containers of hazardous substances like parts cleaners, primers, sealants, and sealant removers.
- Failure to comply could result in death or serious injury.

### ⚠ CAUTION

#### FLYING OBJECT HAZARD!



- ALWAYS wear eye protection when servicing engine and when using compressed air or high-pressure water. Dust, flying debris, compressed air, pressurized water or steam may injure your eyes.
- Failure to comply may result in minor or moderate injury.

## REMOVAL OF FUEL INJECTION PUMP

1. Remove fuel supply line from the fuel injection pump.
2. Remove fuel injector return line.
3. Remove fuel tank return line.
4. Disconnect the electrical connection to the magnetic valve (stop solenoid) **(Figure 7-41, (1))**.

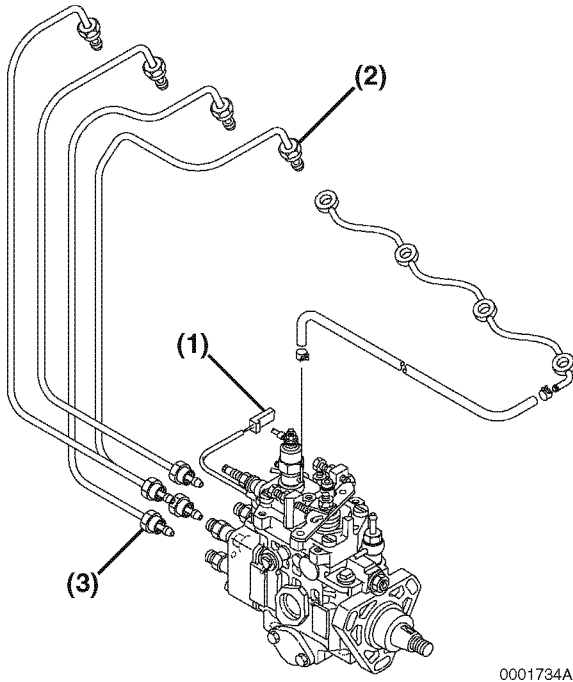

**Figure 7-41**

5. Disconnect the throttle linkage.
6. Remove the high pressure fuel lines.
  - First loosen the high pressure fuel line nuts **(Figure 7-41, (2))** at the fuel injectors.

### NOTICE

When loosening or tightening the lines at the fuel injectors, you must hold the fuel injector with a second wrench to prevent the injector from turning and damaging the fuel return line fitting.

- Then loosen the high pressure fuel line nuts **(Figure 7-41, (3))** on the fuel injection pump.
- Finish loosening all the high pressure fuel line nuts and remove the fuel lines as an assembly. Be careful not to bend any of the fuel lines.

### NOTICE

Remove the high-pressure fuel injection lines as an assembly whenever possible. Disassembling the high-pressure fuel injection lines from the retainers or bending any of the fuel lines will make it difficult to reinstall the fuel lines.

Note: It is necessary to remove the bolt **(Figure 7-42, (1))** holding the dipstick tube clamp. Rotate the dipstick tube to one side to allow you to remove the high pressure fuel line assembly.

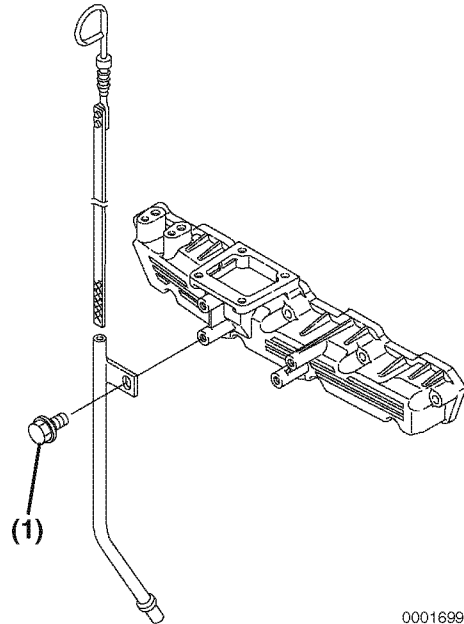

**Figure 7-42**

7. Remove the two bolts **(Figure 7-43, (1))** from the L-shaped brackets that holds the injection pump at the bottom / rear.

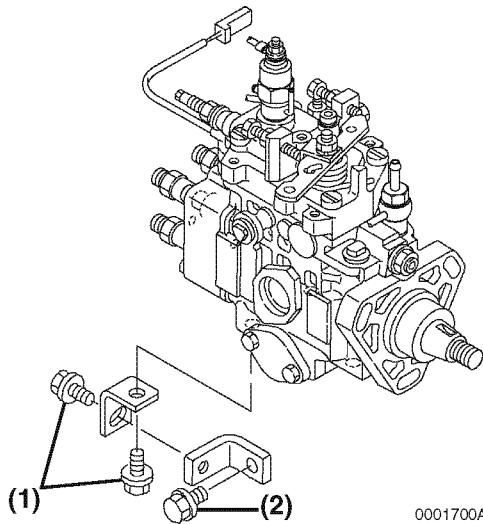
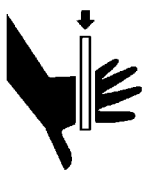

Figure 7-43

- Loosen the bolt (Figure 7-43, (2)) that fastens the remaining bracket to the cylinder block and pivot down and away from the injection pump.
8. Loosen the alternator adjusting bolt and pivot the alternator toward the engine.

**CAUTION**

**PINCH HAZARD!**



Carefully rotate the alternator toward the cylinder block while loosening the V-belt. Failure to comply may result in minor or moderate injury.

9. Remove the cooling fan (Figure 7-44, ((1))), spacer (if equipped) (Figure 7-44, (2)) and V-belt (Figure 7-44, (3)).

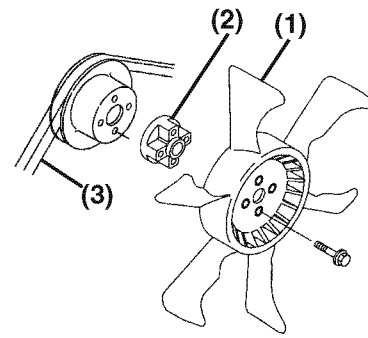

Figure 7-44

10. Remove the seven bolts from the fuel injection pump cover (Figure 7-45, (1)) on the front gear case. Remove the cover.

Note: The cover is secured with an adhesive sealant. Use a gasket scraper to separate the cover from the gear case.

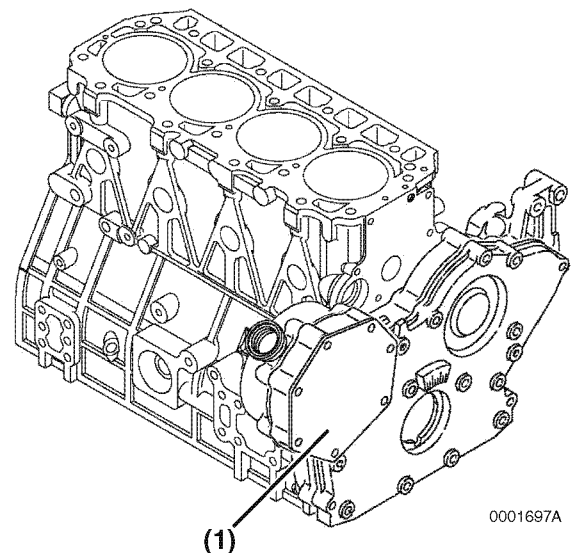
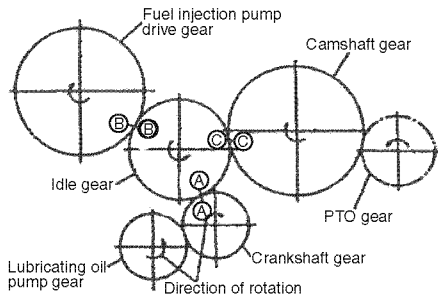

Figure 7-45

11. To aid in reassembly, mark one tooth on the idle gear and two teeth on the pump drive gear with a dot of white paint. See (Figure 7-46).

## NOTICE

Do not rotate the engine with the injection pump removed.



0001709

**Figure 7-46**

Also make matching marks (**Figure 7-47, (1)**) on the rear of the gear case housing and on the fuel injection pump mounting flange before loosening the injection pump mounting nuts.

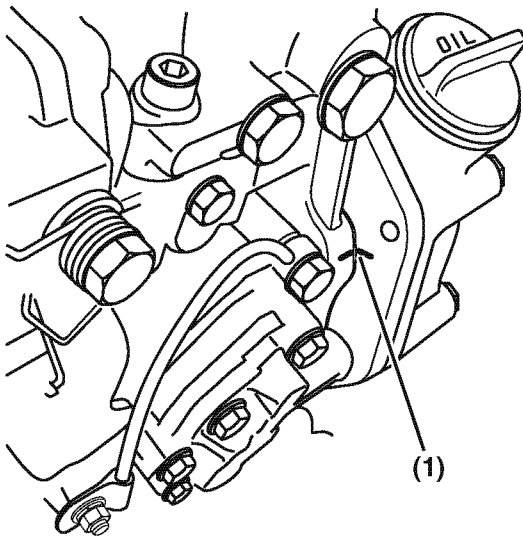

0000593A

**Figure 7-47**

12. While holding the engine from turning with a wrench on the crankshaft pulley bolt, remove the pump drive gear retaining nut (**Figure 7-48, (1)**) and lock washer (**Figure 7-48, (2)**).

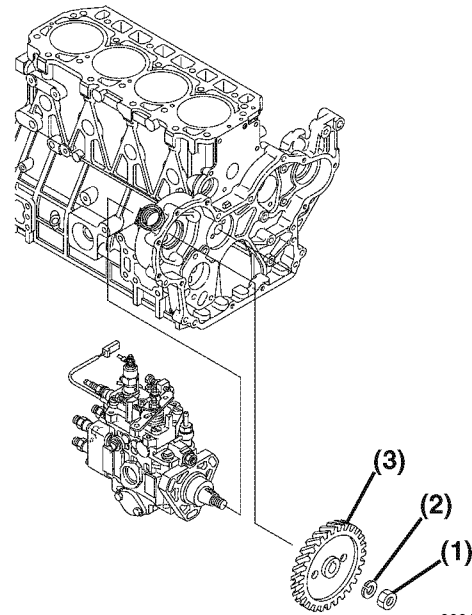

0001698A

**Figure 7-48**

13. Using a two-bolt gear puller, remove the injection pump drive gear (**Figure 7-48, (3)**) from the injection pump shaft.

Note: The injection pump shaft is tapered with a woodruff key. Once you have applied some pressure with the puller. A slight hammer "tap" on the center puller bolt will help "pop" the gear from the shaft.

14. Remove the three nuts securing the fuel injection pump to the rear of the gear case.
15. Remove the fuel injection pump.
16. If the fuel injection pump requires servicing, it must be taken to an authorized ZEXEL fuel injection shop.

## INSTALLATION OF THE FUEL INJECTION PUMP

1. Secure the fuel injection pump mounting flange to the rear of the gear case housing with three nuts. Be sure to match the marks (Figure 7-49, (1)) on the rear of the gear case housing and on the fuel injection pump mounting flange.

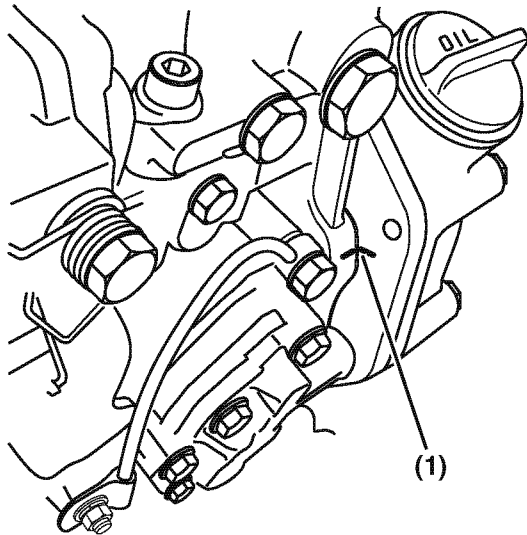

0000593A

Figure 7-49

2. Install the injection pump drive gear (Figure 7-51, (3)) on the injection pump shaft lining up the two marks you made on the pump drive gear with the mark you made on the idle gear. See (Figure 7-46).

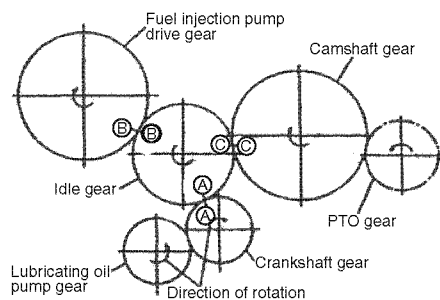

0001709

Figure 7-50

3. Install the drive gear retaining nut (Figure 7-51, (1)) and washer (Figure 7-51, (2)). While holding the engine with a wrench on the crankshaft pulley bolt, torque the retaining nut to 43.5 - 51 ft lbs (59-69 N·m, 5 - 5.4 kgf·m).

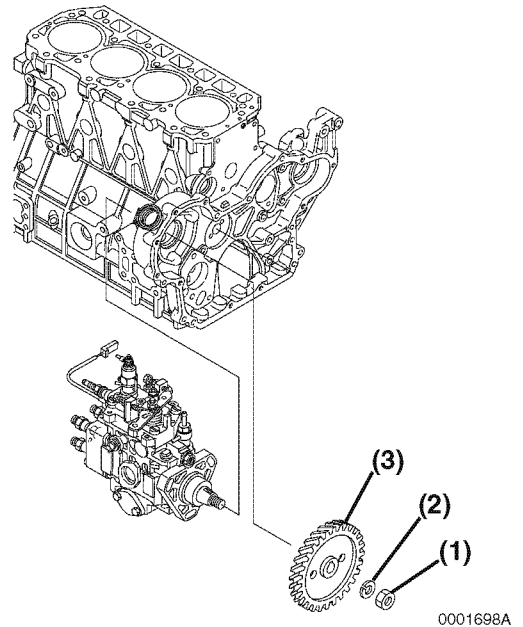
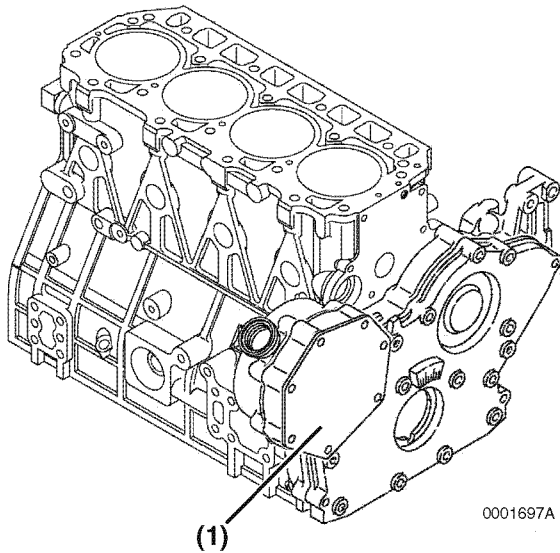

Figure 7-51

4. Thoroughly clean all old sealant from the fuel injection pump cover (Figure 7-52, (1)) and gear case housing. Apply ThreeBond, Yanmar Part No. 977770-01212, or equivalent sealant to the fuel injection pump cover. Install the fuel injection pump cover on the front gear case with seven bolts. Tighten the bolts to the specified torque.



**Figure 7-52**

5. Reinstall the cooling fan (**Figure 7-53, (1)**), spacer (if equipped) (**Figure 7-53, (2)**) and V-belt (**Figure 7-53, (3)**).

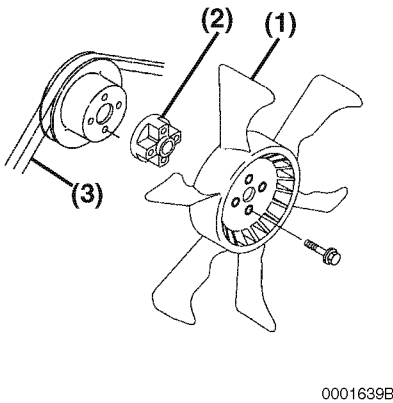

**Figure 7-53**

6. Pivot the alternator away from the engine and adjust the V-belt tension. See *Check and Adjust Cooling Fan V-belt* on page 5-9.
7. Tighten the alternator adjusting bolt. See *Check and Adjust Cooling Fan V-belt* on page 5-9.
8. Pivot the bracket that fastens the fuel injection pump to the cylinder back up and toward the fuel injection pump. Retighten the bolt (**Figure 7-54, (2)**) that fastens it to the cylinder block.

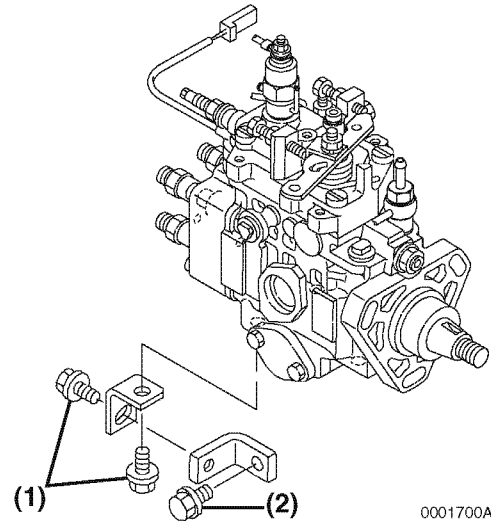

**Figure 7-54**

9. Reinstall the two bolts (**Figure 7-54, (1)**) to the L-shaped bracket that holds the injection pump at the bottom / rear. Tighten the two bolts and the bolt that secures the bracket to the cylinder block to specified torque.
10. Reinstall the high pressure fuel lines.
  - Replace the high pressure fuel lines as an assembly. Be careful not to bend any of the high pressure fuel lines.
  - Start all the high pressure fuel line nuts by hand, leaving those nuts on the fuel injection pump and fuel injectors untightened.
  - Tighten the high pressure fuel line nuts (**Figure 7-55, (2)**) on the fuel injection pump.
  - Tighten the high pressure fuel line nuts (**Figure 7-55, (1)**) on the fuel injectors.



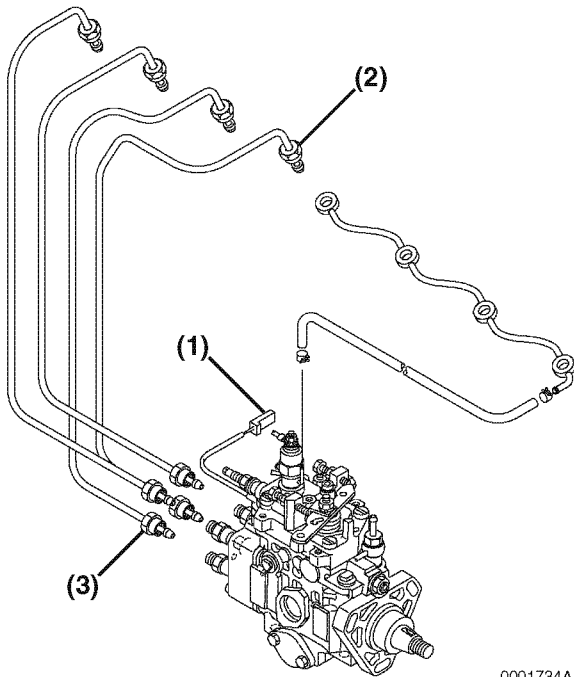

Figure 7-55

0001734A

11. Reconnect the throttle linkage.
12. Reconnect the electrical connection to the magnetic valve (stop solenoid) (Figure 7-55, (1)).
13. Reinstall fuel tank return line.
14. Reinstall fuel injector return line.
15. Reinstall fuel supply line to the fuel injection pump.
16. Prime the fuel system and check for leaks.

## CHECKING / ADJUSTMENT OF FUEL INJECTION TIMING

1. Using a wrench on the front crankshaft pulley bolt, rotate the engine clockwise until the timing mark on the crankshaft pulley is aligned with the "O" or TDC (Top Dead Center) mark on the timing grid of the gear case cover.
2. Remove the center bolt (Figure 7-56, (1)) and sealing washer from the rear of the fuel injection pump.

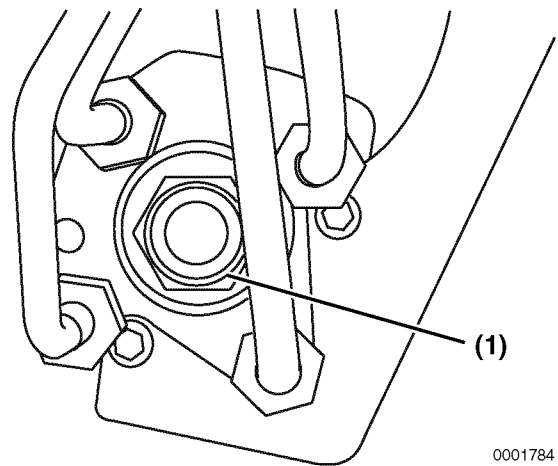

0001784

Figure 7-56

3. Locate Yanmar timing tool (P/N 119770-02020) (Figure 7-57, (1)). Install a dial indicator into the timing tool.

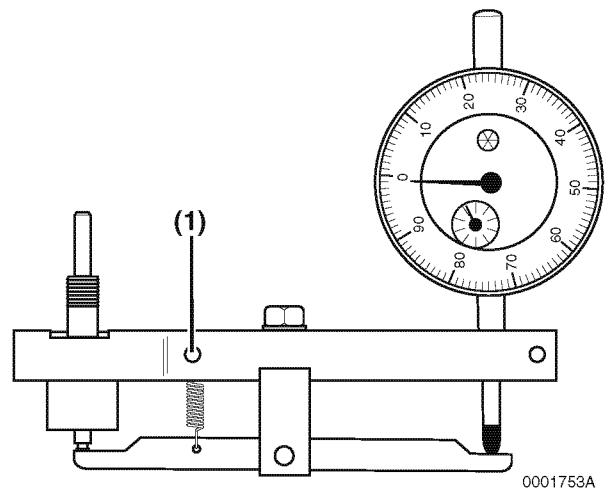

0001753A

Figure 7-57

4. Install Yanmar timing tool (Figure 7-58, (1)), into the port where the bolt was removed. This will provide a reading of the injection pump plunger lift.

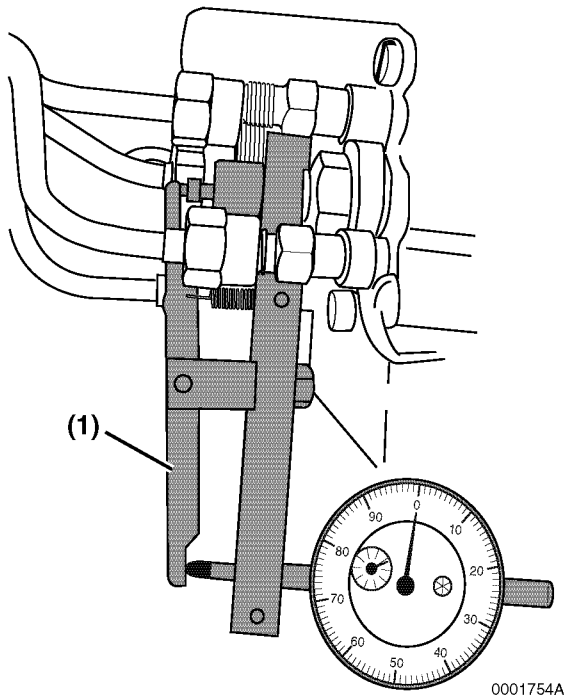

**Figure 7-58**

5. Rotate the engine about 25° in the counterclockwise direction. The dial indicator should move for approximately the first 10° of engine rotation and then stop. When you reach approximately the 25° position, rotate the engine slightly back and forth to make sure the needle of the dial indicator does not move.
6. Set the dial indicator to "0".
7. Rotate the engine in the clockwise rotation until the timing mark on the crankshaft pulley is aligned with the mark at 4, 6 and 8.5° ATDC (After Top Dead Center) on the timing grid on the gear case cover.
  - 4TNE92 4deg ATDC
  - 4TNE94L 4deg ATDC
  - 4TNE98 (Tier2) 6deg ATDC
  - 4TNE98 (Tier3) 8.5deg ATDC.
8. If the injection timing is correct, the dial indicator should read 0.038 - 0.041 in (0.97 - 1.03 mm).

9. If the injection timing is not correct, loosen the three fuel Injection pump mounting nuts and the bolts retaining the bottom / rear L-shaped injection pump mounting brackets. Rotate the injection pump to bring the dial indicator reading into the correct range.

10. Then retighten the pump mounting nuts and the mounting bracket bolts.

Note: Rotating the injection pump away from the engine advances the injection timing. Rotating the injection pump toward the engine retards the injection timing.

11. Remove the timing tool and dial indicator. Replace and tighten the center bolt and sealing washer into the injection pump port.

## SERVICING THE FUEL INJECTORS

### Removal of the Fuel Injectors

1. Remove the high pressure fuel lines.

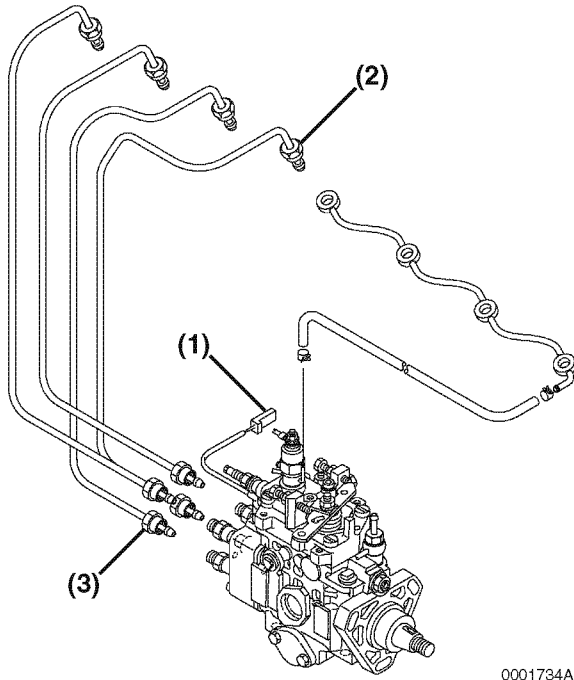

**Figure 7-59**

- First just loosen the high pressure fuel line nuts (**Figure 7-59, (2)**) at the fuel injectors.

### NOTICE

When loosening or tightening the lines at the fuel injectors, you must hold the fuel injector with a second wrench to prevent the injector from turning and damaging the fuel return line fitting.

- Then loosen the high pressure fuel line nuts (**Figure 7-59, (3)**) on the fuel injection pump.
- Finish loosening all the high pressure fuel line nuts and remove the fuel lines as an assembly. Be careful not to bend any of the fuel lines.

### NOTICE

Remove the high-pressure fuel injection lines as an assembly whenever possible. Disassembling the high-pressure fuel injection lines from the retainers or bending any of the fuel lines will make it difficult to reinstall the fuel lines.

Note: It is necessary to remove the bolt (**Figure 7-60, (1)**) holding the dipstick tube clamp. Rotate the dipstick tube to one side to allow you to remove the high pressure fuel line assembly.

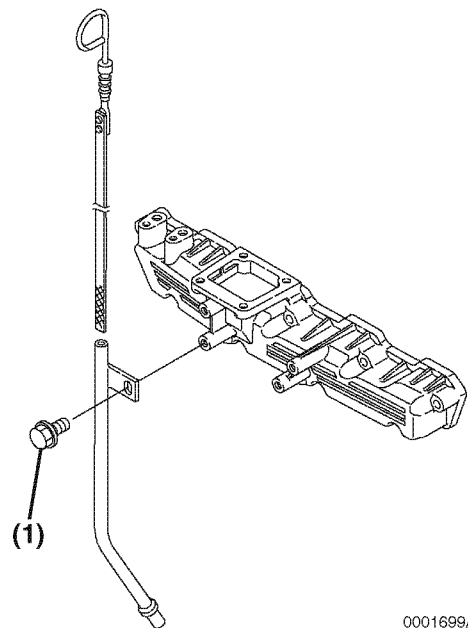

**Figure 7-60**

2. Unscrew the fuel injectors from the cylinder head. Also remove the two copper washers and the nozzle protectors that will remain in the cylinder head.

## Inspection and Testing of the Fuel Injectors

Visually inspect the fuel injectors and nozzle protectors for deposits or damage. Clean and repair as necessary.

### Test Procedure Using a Nozzle Tester

1. Visually inspect the fuel injectors and nozzle protectors for deposits or damage. Clean, repair or replace as necessary.
2. Test the fuel injector using an injection nozzle tester. Use clean, filtered fuel or F.I.E. calibration fluid for the test.
3. Using the correct adaptor, connect the fuel injector to the high-pressure pipe of the nozzle tester. Aim the fuel injector into a suitable container to catch the fuel spray.

### **WARNING**

- Never inject fuel towards you. Since the fuel is injected at high pressure from the nozzle, it may penetrate the skin, resulting in injury.
- Never inject fuel towards a fire source. Atomized fuel is highly flammable and may cause fire or skin burning.

4. Pump the operating lever of the tester slowly, observing the pressure reading at the point where the fuel injector begins spraying fuel. The fuel injectors for these engines should begin spraying fuel at 1711 - 1914 PSI (11.8 - 13.2 MPa). The opening pressure may be adjusted by adding or subtracting internal fuel injector shims.

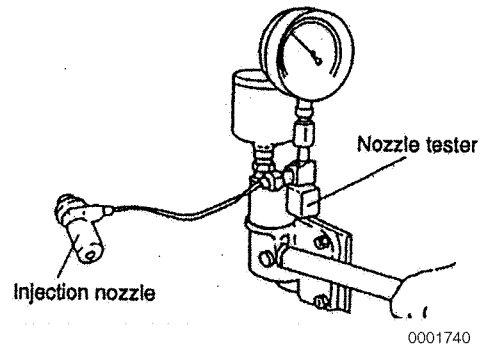

**Figure 7-61**

5. Adding or removing a 0.1 mm shim (shims are available in 0.4 mm increments) changes the pressure by 174 - 319 PSI (1.2 - 2.2 MPa).

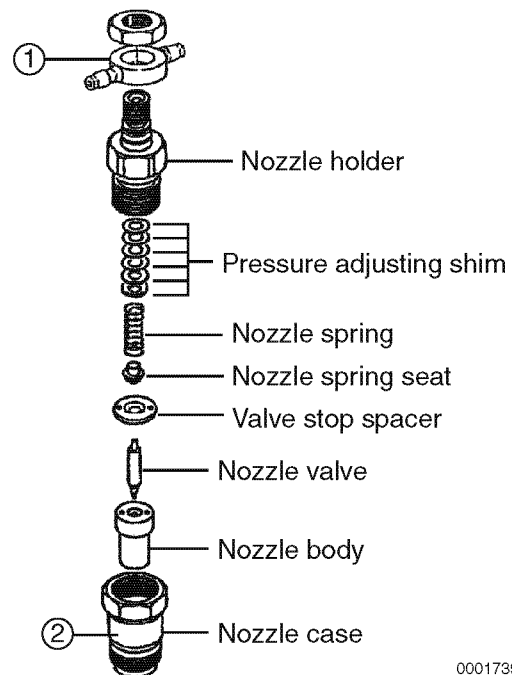
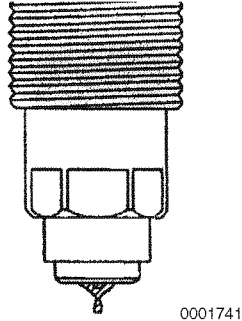

**Figure 7-62**

6. Pump the operating lever more rapidly to repeatedly "pop" the injector and observe the spray pattern. See *Judgement Criteria on Atomization Condition* on page 7-38 for examples of "good" and "bad" spray patterns.

7. Finally. Pump the operating lever slowly to hold the pressure steady at a point just below the “pop off” pressure point. Observe the injector to see that it is sealing properly and is not “dripping”.

Abnormal



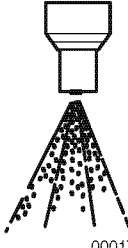

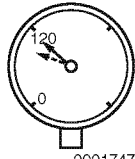

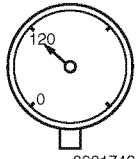
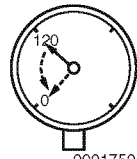
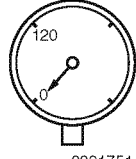

**Figure 7-63**

8. If the fuel injector fails any of these tests, it should be repaired or replaced as necessary.

# FUEL SYSTEM

## Judgement Criteria on Atomization Condition

	A	B	C	D	E
Injection Pattern	 0001742	 0001743	 0001744	 0001745	 0001746
Pressure Gauge Reading	 0001747 Pointer fluctuate around the valve opening pressure.	 0001748 Same as A.	 0001749 Pointer stays at a position near the valve opening pressure.	 0001750 Although the pointer reaches the valve opening pressure, the pressure drop is large.	 0001751 Pressure does not increase even when the tester lever is operated.
Atomization Pattern	Roughly uniform.	Atomization is excessively one sided.	Although atomized, the needle does not pulsate (burner like shape).	Bar shape with excessive after drops.	Drops (bar shape).
Possible Cause	(Normal)	<ol style="list-style-type: none"> <li>Normally caused by carbon contamination of the nozzle tip.</li> <li>Sometimes caused by flaws in or damage to the needle tip.</li> </ol>	<ol style="list-style-type: none"> <li>Caused by excessive carbon contamination of the nozzle tip.</li> <li>Sometimes caused by contamination.</li> </ol>	<ol style="list-style-type: none"> <li>Damage to the seat.</li> <li>Contamination of seat by fine foreign particles.</li> <li>Excessively worn seat.</li> </ol>	<ol style="list-style-type: none"> <li>Sticking of needle.</li> <li>Excessively damaged or worn seat.</li> <li>Contamination of seat by foreign matter.</li> <li>Damaged or broken internal parts of nozzle holder.</li> </ol>

## Cleaning of Nozzle

1. Clean the exterior of the nozzle, taking care not to damage the needle.
2. Pull out the needle and clean carefully so as not to damage it. Avoid use of hard, metallic tools.
3. Check for dents, damage, rusting and wear. Pay special attention to the stem and seat of the needle.
4. When setting the needle on the nozzle body after thorough cleaning, check that it falls by its own weight.

## Installation of Fuel Injectors

1. Install a new copper gasket at the bottom of the injector well.
2. Install the nozzle protector in the injector well.
3. Install the second copper gasket on top of the nozzle protector.
4. Install the fuel injectors. Torque to 29.4 ft-lb (39.2 N·m).
5. Install the fuel return line fitting using new copper gaskets.
6. Tighten the fuel return line retaining nuts to 32.5 ft-lb (44.1 N·m).

### NOTICE

When loosening or tightening the lines at the fuel injectors, you must hold the fuel injector with a second wrench to prevent the injector from turning and damaging the fuel return line fitting.

7. Reinstall the high pressure fuel lines and fuel return line.
  - Replace the high pressure fuel lines as an assembly. Be careful not to bend any of the high pressure fuel lines.
  - Start all the high pressure fuel line nuts by hand, leaving those nuts on the fuel injection pump and fuel injectors untightened.
  - Tighten the high pressure fuel line nuts (**Figure 7-64, (2)**) on the fuel injection pump.

- Tighten the high pressure fuel line nuts (**Figure 7-64, (1)**) on the fuel injectors.

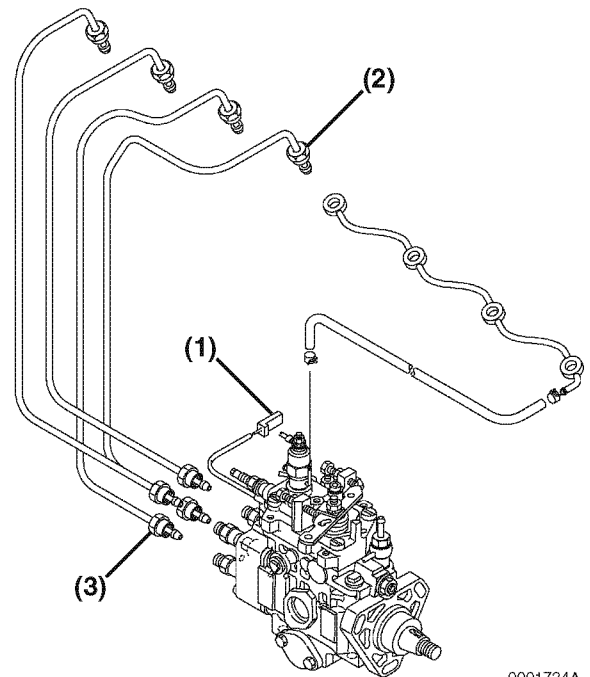

**Figure 7-64**

0001734A

8. Prime the fuel system and check for leaks.

**This Page Intentionally Left Blank**



## Section 8

# COOLING SYSTEM

---

### Table of Contents

	Page
Measuring Instruments.....	8-3
Cooling System Diagram.....	8-4
Engine Coolant Pump Components.....	8-5
Before You Begin Servicing .....	8-6
Engine Coolant System Check.....	8-7
Disassembly of Engine Coolant Pump.....	8-7
Cleaning and Inspection.....	8-9
Thermostat .....	8-9
Radiator Cap .....	8-9
Assembly of Engine Coolant Pump.....	8-10
Assembly of All Coolant Pump Models.....	8-11

**This Page Intentionally Left Blank**

This section of the *Service Manual* describes the procedures necessary to service the engine coolant pump.

**MEASURING INSTRUMENTS**

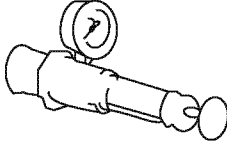
1	Cooling System Tester	For checking water leakage	 0000842
---	-----------------------	----------------------------	--

## COOLING SYSTEM DIAGRAM

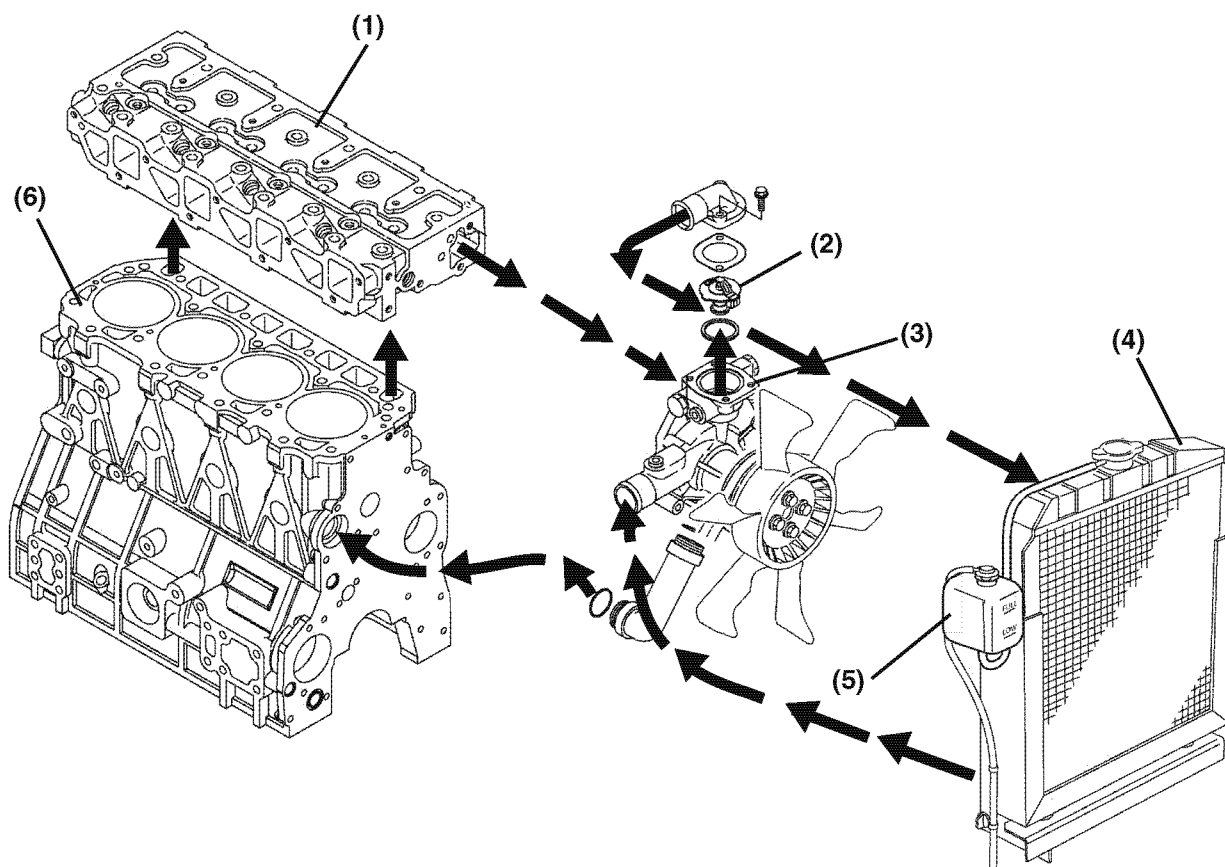

0001669A

**Figure 8-1**

- |                        |                          |
|------------------------|--------------------------|
| 1. Cylinder Head       | 4. Radiator              |
| 2. Thermostat          | 5. Coolant Recovery Tank |
| 3. Engine Coolant pump | 6. Cylinder Block        |

ENGINE COOLANT PUMP COMPONENTS

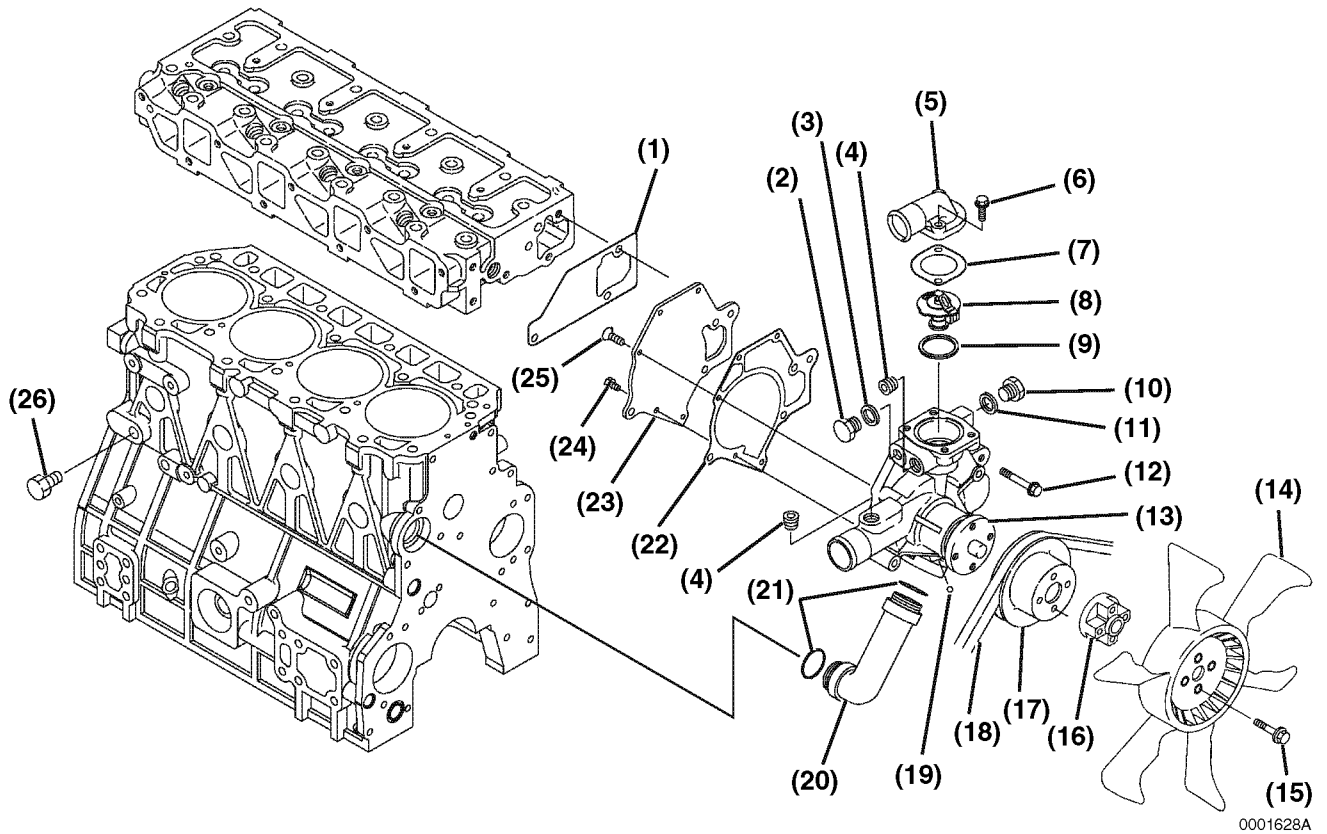

0001628A

Figure 8-2

- |                          |                           |
|--------------------------|---------------------------|
| 1. Coolant Pump Gasket   | 14. Engine Coolant Fan    |
| 2. Plug, M12 x 1.5       | 15. Bolt, M8x12 Plated    |
| 3. Gasket, Round         | 16. Spacer                |
| 4. Plug, NPT 3/8         | 17. Coolant Pump V-pulley |
| 5. Thermostat Cover      | 18. V-belt                |
| 6. Bolt, M8 x 25 Plated  | 19. 1/4 Steel Ball        |
| 7. Gasket                | 20. Coolant Pump Pipe     |
| 8. Thermostat            | 21. O-ring                |
| 9. Thermostat Gasket     | 22. Gasket                |
| 10. Plug, M16            | 23. Cover                 |
| 11. Gasket               | 24. Bolt, M6 x 16         |
| 12. Bolt, M8 x 55 Plated | 25. Bolt, M6 x 15         |
| 13. Water Pump Assembly  | 26. Drain Plug            |

## BEFORE YOU BEGIN SERVICING

### **⚠ DANGER**

#### **SCALD HAZARD!**



- NEVER remove the radiator cap if the engine is hot. Steam and hot engine coolant will spurt out and seriously burn you. Allow the engine to cool down before you attempt to remove the radiator cap.
- Securely tighten the radiator cap after you check the radiator. Steam can spurt out during engine operation if the cap is loose.
- ALWAYS check the level of engine coolant by observing the reserve tank.
- Failure to comply will result in death or serious injury.

### **⚠ WARNING**

#### **SEVER HAZARD!**



- Stop the engine before you begin to service it.
- NEVER leave the key in the key switch when you are servicing the engine. Someone may accidentally start the engine and not realize you are servicing it. This could result in a serious injury.
- If you must service the engine while it is operating, remove all jewelry, tie back long hair, and keep your hands, other body parts and clothing away from moving / rotating parts.
- Failure to comply could result in death or serious injury.

### **⚠ WARNING**

#### **BURN HAZARD!**



- If you must drain the engine oil while it is still hot, stay clear of the hot engine oil to avoid being scalded. Make sure you wear eye protection.
- Failure to comply could result in death or serious injury.

### **⚠ WARNING**

#### **EXPOSURE HAZARD!**

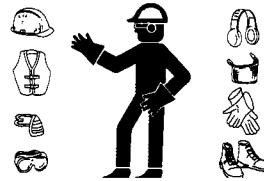

- Always read and follow safety related precautions found on containers of hazardous substances like parts cleaners, primers, sealants, and sealant removers.
- Failure to comply could result in death or serious injury.

### **⚠ CAUTION**

#### **FLYING OBJECT HAZARD!**



- ALWAYS wear eye protection when servicing engine and when using compressed air or high-pressure water. Dust, flying debris, compressed air, pressurized water or steam may injure your eyes.
- Failure to comply may result in minor or moderate injury.

## ENGINE COOLANT SYSTEM CHECK

Check the engine coolant system for leakage.

### **⚠ DANGER**

#### **SCALD HAZARD!**



- **NEVER** remove the radiator cap if the engine is hot. Steam and hot engine coolant will spurt out and seriously burn you. Allow the engine to cool down before you attempt to remove the radiator cap.

- **Securely tighten the radiator cap after you check the radiator. Steam can spurt out during engine operation if the cap is loose.**
- **ALWAYS** check the level of engine coolant by observing the reserve tank.
- **Failure to comply will result in death or serious injury.**

1. With the radiator properly filled, install a cooling system tester (Figure 8-3, (1)).

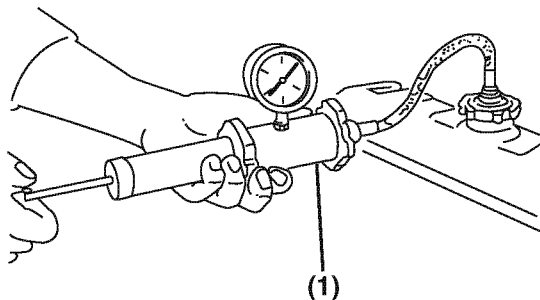

0000577A

**Figure 8-3**

2. Apply 10.8 - 14.8 psi (75 - 105 kPa, 0.75 - 1.05 kgf/cm<sup>2</sup>) to the cooling system. If the pressure reading drops, the engine coolant system is leaking. Identify the source of the leak and repair.

## DISASSEMBLY OF ENGINE COOLANT PUMP

Verify the condition of the engine coolant pump before disassembling it from the engine. Check the engine coolant pump shaft bearing for abnormal noise, sticking, excessive play and water leakage. Replace the coolant pump if any of these conditions are present.

### **NOTICE**

If the engine coolant pump must be replaced, replace the engine coolant pump as an assembly only. Do not attempt to repair the engine coolant pump or replace individual components.

1. Make sure the engine and engine coolant are not hot.
2. Before removing the engine coolant pump or thermostat, it will be necessary to drain the engine coolant. Drain the coolant into a clean container if the coolant is to be reused. Otherwise, properly dispose of the coolant.

### **⚠ WARNING**

#### **BURN HAZARD!**



- **Wait until the engine cools before you drain the engine coolant. Hot engine coolant may splash and burn you.**
- **Failure to comply could result in death or serious injury.**

- Drain the coolant from the radiator. Remove the radiator cap (Figure 8-4, (1)).
- Remove the drain plug or open the drain cock (Figure 8-4, (2)) at the lower portion of the radiator and drain the engine coolant.

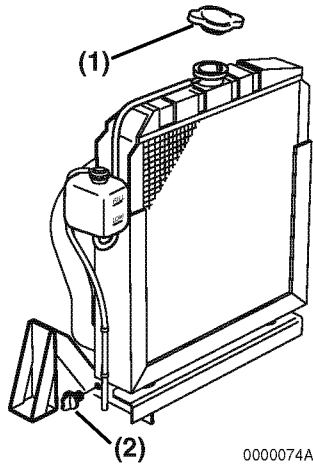

**Figure 8-4**

- Drain the coolant from the engine block. Remove the coolant drain plug (Figure 8-5, (1)) from the engine block.

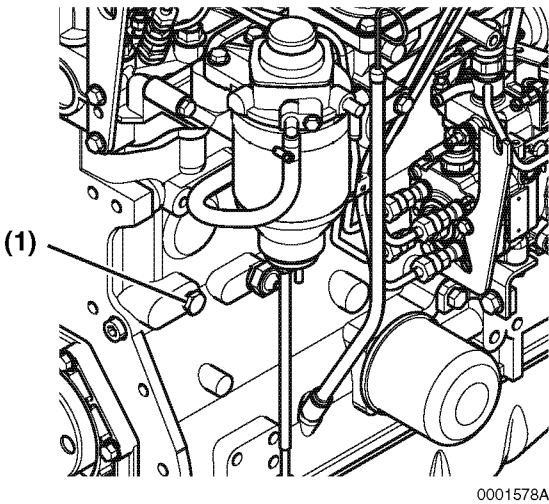

**Figure 8-5**

3. Loosen the V-belt.
4. Loosen the alternator mounting bolts and pivot the alternator out of the way.

## ⚠ CAUTION

### PINCH HAZARD!



Carefully rotate the alternator toward the cylinder block while loosening the V-belt. Failure to comply may result in minor or moderate injury.

5. Remove the engine coolant fan guard (if equipped), engine coolant fan (if equipped) (Figure 8-6, (2)), spacer (Figure 8-6, (3)), engine coolant pump V-pulley (Figure 8-6, (4)) and V-belt.

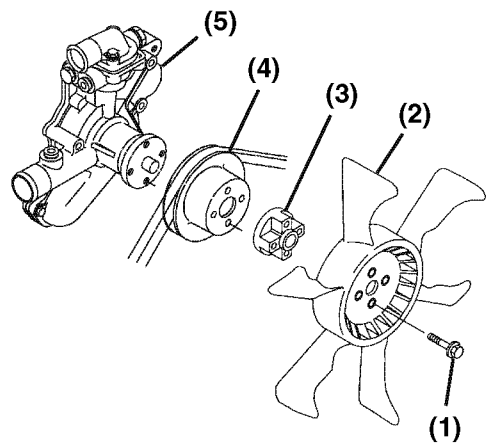

**Figure 8-6**

## Disassembly of the Coolant Pumps

1. Remove the engine coolant pump bolts (Figure 8-7, (2)). Remove the engine coolant pump (Figure 8-7, (1)). Discard the gasket (Figure 8-7, (6)).
2. Remove coolant pump pipe (Figure 8-7, (3)) from engine block. Discard the O-rings (Figure 8-7, (4)).
3. Remove the bolts (Figure 8-7, (5)) holding the cover (Figure 8-7, (7)) on the pump. Discard the gasket (Figure 8-7, (8)).



## CLEANING AND INSPECTION

### Thermostat

1. Check for proper operation of the thermostat. Place the thermostat (**Figure 8-9, (1)**) and an accurate thermometer (**Figure 8-9, (2)**) in warm water.

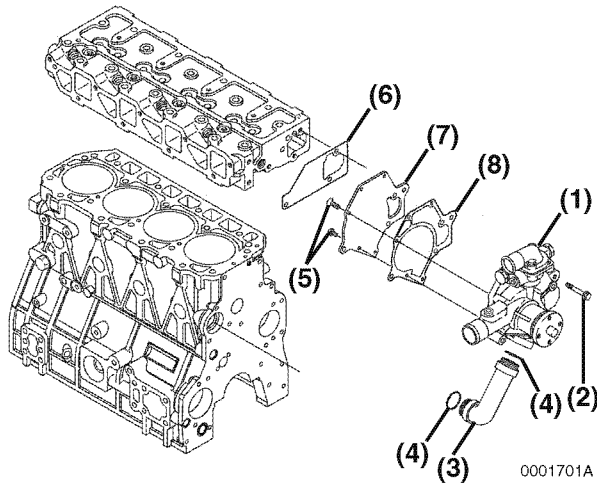

**Figure 8-7**

4. Remove the thermostat cover (**Figure 8-8, (1)**). Discard the gasket (**Figure 8-8, (2)**).

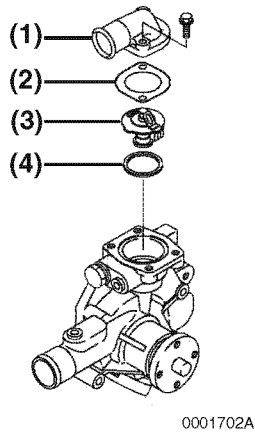

**Figure 8-8**

5. Remove the thermostat (**Figure 8-8, (3)**). Discard the gasket (**Figure 8-8, (4)**).

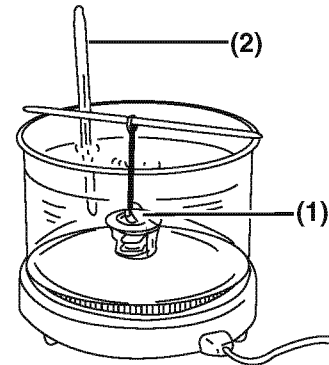

0000577A

**Figure 8-9**

2. Slowly increase temperature of the water using an external heat source.
3. The thermostat is normal if it starts to open at 160°F (71°C) and fully opens at 185°F (85°C).

### Radiator Cap

1. Check for proper operation of the radiator cap. Install the radiator cap (**Figure 8-10, (1)**) on a cooling system tester.

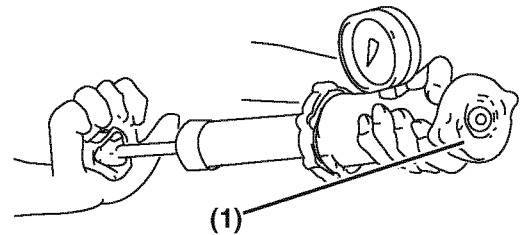

0000577A

**Figure 8-10**

2. Apply 10.8 - 14.8 psi (75 - 105 Kpa, 0.75 - 1.05 kgf/cm<sup>2</sup>) to the radiator cap. The radiator cap must open within the specified range.

## COOLING SYSTEM

### ASSEMBLY OF ENGINE COOLANT PUMP

1. Install the thermostat (Figure 8-11, (3)) using a new O-ring (Figure 8-11, (4)).

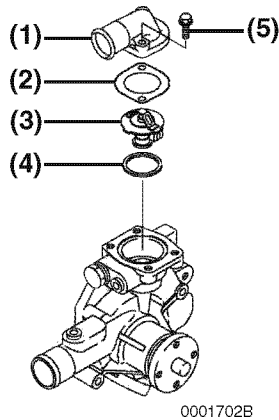

**Figure 8-11**

2. Install the thermostat cover (Figure 8-11, (1)) using a new gasket (Figure 8-11, (2)). Tighten the thermostat cover bolts (Figure 8-11, (5)) to the specified torque.
3. Assemble the cover (Figure 8-12, (7)) Using a new gasket (Figure 8-12, (8)).

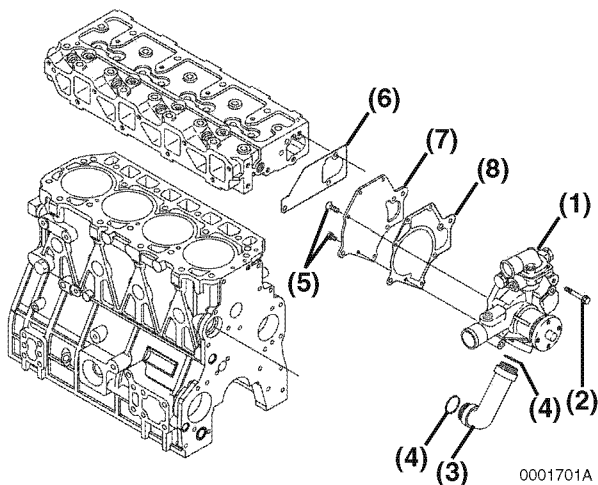

**Figure 8-12**

4. Reinstall the coolant pump pipe (Figure 8-12, (3)) to the engine coolant pump using a new O-ring (Figure 8-12, (4)).

5. Position the engine coolant pump (Figure 8-12, (1)) on the engine. Be sure a new O-ring (Figure 8-12, (4)) is positioned between the coolant pump pipe and engine. Install the engine coolant pump bolts. Tighten the bolts (Figure 8-12, (2)) to the specified torque.

## Assembly of All Coolant Pump Models

1. Install the engine coolant pump V-pulley (**Figure 8-13, (4)**), spacer (**Figure 8-13, (3)**) engine coolant fan (**Figure 8-13, (2)**) and engine coolant fan guard (if equipped).

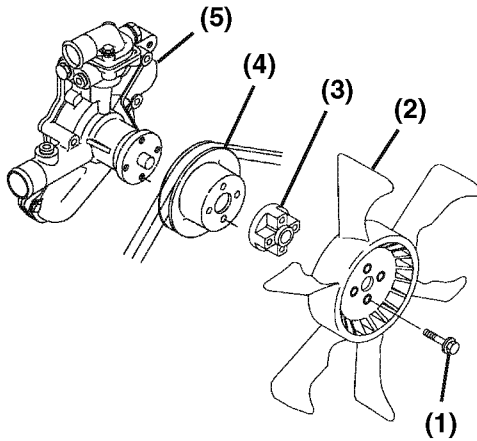

0001639A

**Figure 8-13**

2. Install the alternator.
3. Inspect the condition of the V-belt. There must be clearance (**Figure 8-14, (1)**) between the V-belt and the bottom of the pulley groove. If there is no clearance (**Figure 8-14, (2)**) between the V-belt and the bottom of the pulley groove, replace the V-belt.

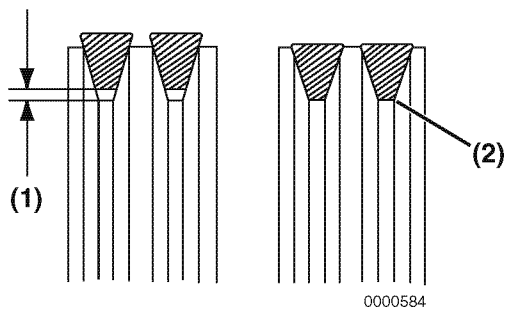

0000584

**Figure 8-14**

4. Install the V-belt. Tighten the V-belt to the proper tension. *See Check and Adjust Cooling Fan V-belt on page 5-9.*
5. Reinstall and tighten the drain plug or close the drain cock in the radiator. Reinstall and tighten the engine block drain plug or reconnect the coolant hose at the oil cooler.
6. Fill radiator and engine with engine coolant. *See Drain, Flush, and Re-fill the Coolant System with New Coolant on page 5-21.*

### NOTICE

- Only use the engine coolant specified. Other engine coolants may affect warranty coverage, cause an internal build up of rust and scale and / or shorten engine life.
- Prevent dirt and debris from contaminating engine coolant. Carefully clean the radiator cap and the surrounding area before you remove the cap.
- NEVER mix different types of engine coolants. This may adversely affect the properties of the engine coolant.

**This Page Intentionally Left Blank**

## Section 9

# LUBRICATION SYSTEM

---

## Table of Contents

	Page
Oil Pump Service Information.....	9-3
Lubrication System Diagram .....	9-4
Checking Engine Oil Pressure .....	9-5
Oil Pump Components .....	9-5
Before You Begin Servicing.....	9-5
Disassembly of Oil Pump .....	9-7
Cleaning and Inspection.....	9-7
Assembly of Oil Pump .....	9-9

**This Page Intentionally Left Blank**

This section of the *Service Manual* describes the procedures necessary to service the Trochoid oil pump.

See *Replace Engine Oil and Engine Oil Filter* on page 5-13 for engine oil and engine oil filter replacement procedures.

## OIL PUMP SERVICE INFORMATION

### Engine Oil Pressure - All Models

Model Number	at Rated Engine rpm	at Low Idle Speed
4TNE92 4TNE94L 4TNE98	42.06 - 56.57 psi (0.29 - 0.39 MPa) (3.0 - 4.0 kgf/cm <sup>2</sup> )	8.5 psi (0.06 MPa, 0.6 kgf/cm <sup>2</sup> ) or greater

### Outer Rotor Outside Clearance - All Models

Model	Standard	Limit	Reference Page
4TNE92 4TNE94L 4TNE98	0.0039 to 0.0061 in (0.100 to 0.155 mm)	0.0098 in (0.25 mm)	<i>Check Outer Rotor Outside Clearance on page 9-8</i>

### Outer Rotor Side Clearance - All Models

Model	Standard	Limit	Reference Page
4TNE92 4TNE94L 4TNE98	0.0020 to 0.0039 in (0.05 to 0.10 mm)	0.0059 in (0.15 mm)	<i>Check Outer Rotor Side Clearance on page 9-8</i>

### Outer Rotor to Inner Rotor Tip Clearance - All Models

Model	Standard	Limit	Reference Page
4TNE92 4TNE94L 4TNE98	—	0.0063 in (0.16 mm)	<i>Outer Rotor to Inner Rotor Tip Clearance on page 9-8</i>

### Rotor Shaft Clearance - All Models

Model	Inspection Item	Standard	Limit	Reference Page
4TNE92 4TNE94L 4TNE98	Gear Case Bearing I.D.	0.5110 to 0.5126 in (12.980 to 13.020 mm)	0.5138 in (13.05 mm)	<i>Check Rotor Shaft Clearance on page 9-8</i>
	Rotor Shaft O.D.	0.5089 to 0.5106 in (12.925 to 12.970 mm)	0.5085 in (12.915 mm)	
	Rotor Clearance	0.0004 to 0.0026 in (0.010 to 0.065 mm)	0.0041 in (0.105 mm)	

## LUBRICATION SYSTEM DIAGRAM

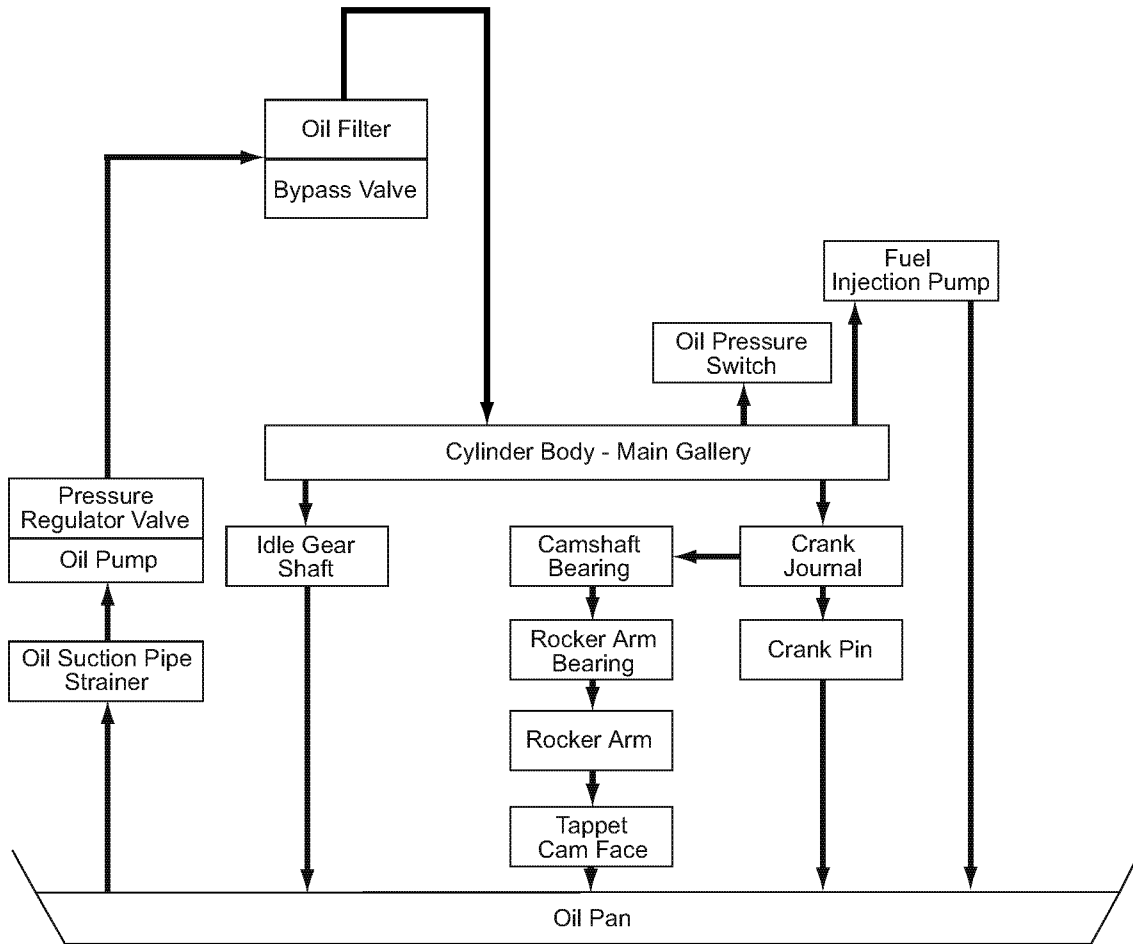

0001624

Figure 9-1



## CHECKING ENGINE OIL PRESSURE

Perform an engine oil pressure check if there is any indication of low oil pressure such as the oil pressure indicator is on or the oil pressure gauge indicates low oil pressure.

See *Engine Oil Pressure - All Models specifications on page 9-3 for the engine oil pressure.*

1. Disconnect the connector from the oil pressure switch (**Figure 9-2, (1)**).

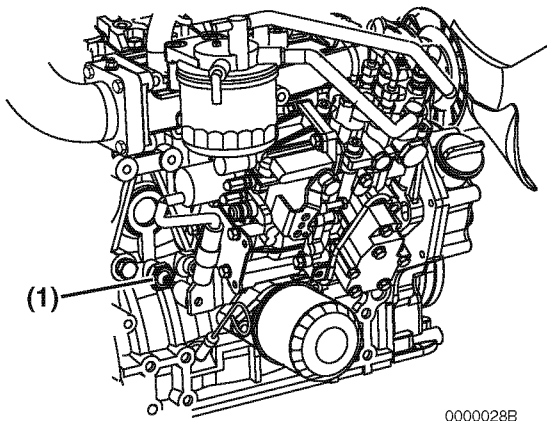

**Figure 9-2**

2. Remove the oil pressure switch.
3. Install a mechanical oil pressure gauge in the oil pressure switch port.
4. Start the engine:
  - If the mechanical oil pressure gauge indicates good oil pressure, replace the faulty oil pressure switch or faulty machine oil pressure gauge.
  - If the mechanical oil pressure gauge indicates low oil pressure, troubleshoot the lubrication system to locate the cause of the low oil pressure. See *Quick Reference Table For Troubleshooting 13-6.*

## Oil Pump Components

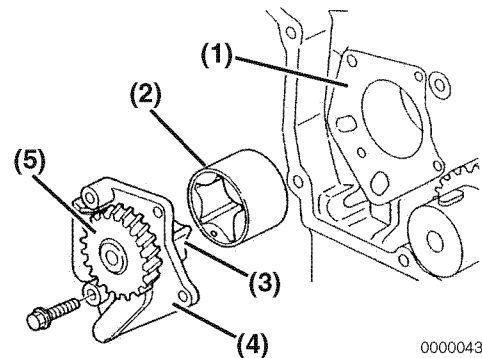

0000043A

1. Gear Case Housing
2. Outer Rotor
3. Inner Rotor
4. Cover Plate
5. Drive Gear

**Figure 9-3**

## Before You Begin Servicing

### NOTICE



NEVER permit anyone to operate the engine or driven machine without proper training.

- Read and understand this Operation Manual before you operate the machine to ensure that you follow safe operating practices and maintenance procedures.
- Machine safety signs and labels are additional reminders for safe operating and maintenance techniques.
- See your authorized Yanmar industrial engine dealer or distributor for additional training.

## ⚠ WARNING

### SEVER HAZARD!



- Stop the engine before you begin to service it.
- NEVER leave the key in the key switch when you are servicing the engine. Someone may accidentally start the engine and not realize you are servicing it. This could result in a serious injury.
- If you must service the engine while it is operating, remove all jewelry, tie back long hair, and keep your hands, other body parts and clothing away from moving / rotating parts.
- Failure to comply could result in death or serious injury.

## ⚠ WARNING

### BURN HAZARD!



- Keep your hands, and other body parts, away from hot engine surfaces such as the muffler, exhaust pipe, turbocharger (if equipped) and engine block during operation and shortly after you shut the engine down. These surfaces are extremely hot while the engine is operating and could seriously burn you.
- Failure to comply could result in death or serious injury.

## ⚠ CAUTION

### FLYING OBJECT HAZARD!



- ALWAYS wear eye protection when servicing engine and when using compressed air or high-pressure water. Dust, flying debris, compressed air, pressurized water or steam may injure your eyes.
- Failure to comply may result in minor or moderate injury.

## NOTICE

- Only use the engine oil specified. Other engine oils may affect warranty coverage, cause internal engine components to seize, or shorten engine life.
- Prevent dirt and debris from contaminating engine oil. Carefully clean the oil cap / dipstick and the surrounding area before you remove the cap.
- NEVER mix different types of engine oil. This may adversely affect the lubricating properties of the engine oil.
- NEVER overfill. Overfilling may result in white exhaust smoke, engine overspeed or internal damage.

## Disassembly of Oil Pump

### NOTICE

If the oil pump must be replaced, replace it as an assembly only. Do not replace individual components

1. Remove the engine coolant fan guard (if equipped), engine coolant fan (**Figure 9-4, (3)**), spacer (**Figure 9-4, (2)**), engine coolant pump V-pulley (**Figure 9-4, (1)**) and V-belt.

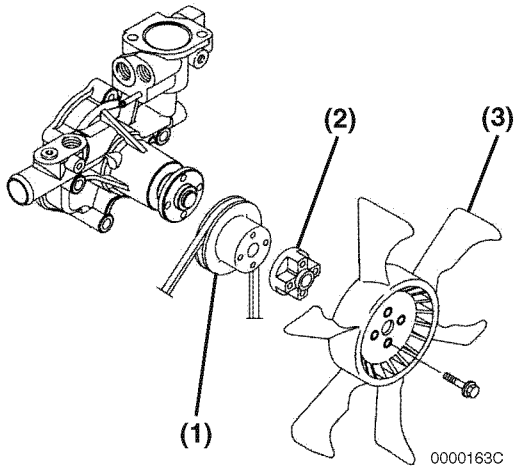

**Figure 9-4**

2. Remove the front crankshaft pulley.
3. Remove the gear case cover (**Figure 9-5, (1)**) assembly.
4. Remove the oil pump assembly bolts. Remove the oil pump assembly (**Figure 9-5, (2)**) from the gear case housing (**Figure 9-5, (3)**).

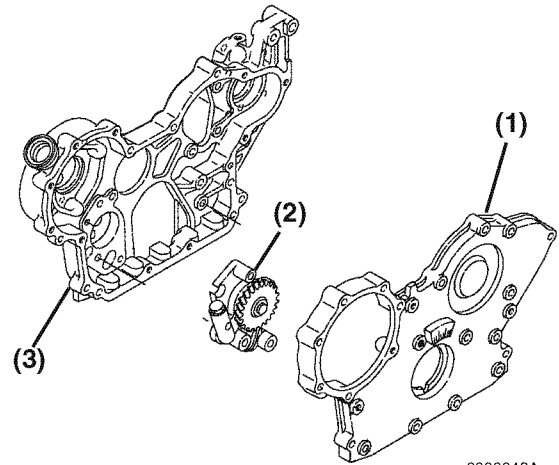

**Figure 9-5**

### Cleaning and Inspection

Wash the oil pump, oil pressure regulator and oil pump cavity. Inspect for wear or damage. Replace as necessary.

### CAUTION

If any oil pump component clearance exceeds its limit, the oil pump must be replaced as an assembly.

# LUBRICATION SYSTEM

## Check Outer Rotor Outside Clearance

Determine the outside clearance of the outer rotor. Insert a feeler gauge between the outer rotor (Figure 9-6, (1)) and gear case oil pump cavity (Figure 9-6, (2)).

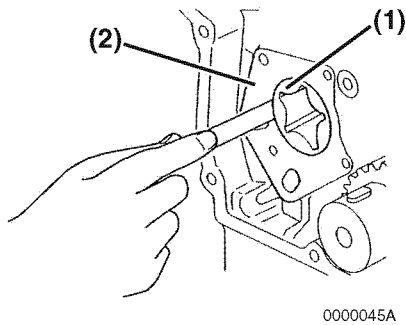

Figure 9-6

See Outer Rotor Outside Clearance - All Models specifications on page 9-3 for the service limit.

## Outer Rotor to Inner Rotor Tip Clearance

Determine the outer rotor to inner rotor tip clearance. Insert a feeler gauge between the top of an inner rotor tooth (Figure 9-7, (1)) and the top of an outer rotor tooth (Figure 9-7, (2)) and measure the clearance.

See Outer Rotor to Inner Rotor Tip Clearance specifications on page 9-3 for the service limit.

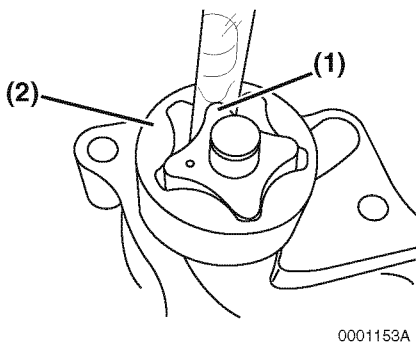

Figure 9-7

## Check Outer Rotor Side Clearance

Determine the side clearance of the outer rotor across the pump cavity. Measure the depression using a depth micrometer (Figure 9-8, (1)).

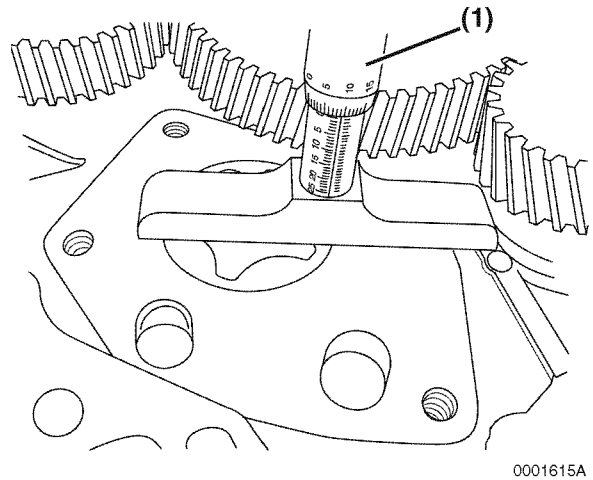

Figure 9-8

See Outer Rotor Side Clearance - All Models specifications on page 9-3 for the service limit.

## Check Rotor Shaft Clearance

Determine the rotor shaft clearance. Measure the outside diameter of the rotor shaft (Figure 9-9, (1)) and the bore diameter in the gear case housing (Figure 9-9, (2)).

Calculate the difference between the two measurements to determine the clearance.

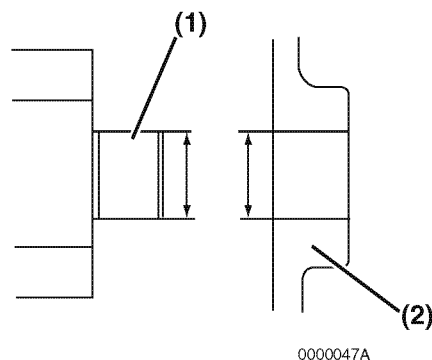
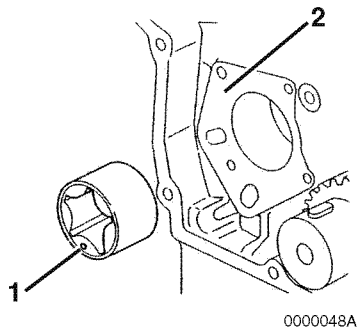

Figure 9-9

See Rotor Shaft Clearance - All Models specifications on page 9-3 for the service limits.

## Assembly of Oil Pump

1. Lubricate the outer rotor and pump bore in the gear case.
2. Install the outer rotor in the gear case housing. Punch mark (**Figure 9-10, (1)**) on end of the outer rotor must face away from the gear case housing (**Figure 9-10, (2)**).



**Figure 9-10**

3. Install the oil pump assembly (**Figure 9-11, (1)**) into the gear case housing (**Figure 9-11, (2)**). Tighten the bolts to specified torque.

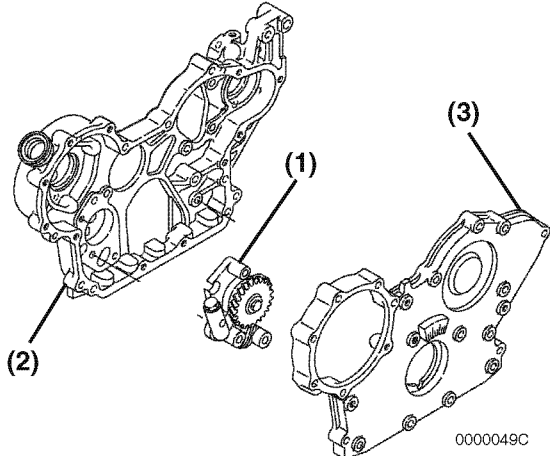

**Figure 9-11**

4. Thoroughly clean all old sealant from the gear case cover (**Figure 9-11, (3)**) and gear case housing (**Figure 9-11, (2)**). Apply ThreeBond Liquid Gasket, Yanmar Part No. 977770-01212, or equivalent sealant to the gear case cover. Install the gear case cover housing. Tighten the cover bolts to the specified torque.
5. Install the crankshaft pulley.
6. Install the engine coolant pump V-pulley (**Figure 9-12, (1)**), spacer (**Figure 9-12, (2)**), engine coolant fan (**Figure 9-12, (3)**) and engine coolant fan guard (if equipped).

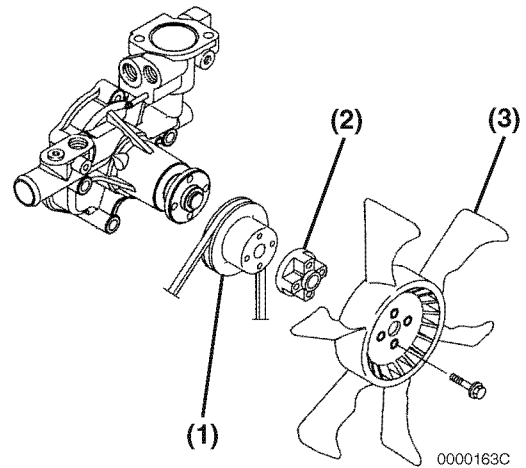

**Figure 9-12**

7. Install the V-belt. Tighten the V-belt to the proper tension. See *Check and Adjust Cooling Fan V-belt* on page 5-9.

**This Page Intentionally Left Blank**

## Section 10

# STARTER MOTOR

---

## Table of Contents

	Page
Starter Motor Service Information .....	10-3
Starter Motor Troubleshooting.....	10-4
Starter Motor Precautions .....	10-5
Starter Motor Servicing.....	10-6
Starter Motor Components .....	10-6
Before You Begin .....	10-7
Starter Motor Removal .....	10-8
Starter Motor Disassembly .....	10-8
Inspection .....	10-10
Starter Motor Assembly .....	10-16
No Load Test.....	10-18
Starter Motor Installation .....	10-18

**This Page Intentionally Left Blank**



This section of the Service Manual describes the servicing of the starter motors.

**STARTER MOTOR SERVICE INFORMATION**

Hitachi Model Number		S13-204	
Yanmar Part Number		129900-77010	
Nominal Output		3.0 HP (2.3 kW)	
Weight		12.1 lbs (5.5 kg)	
Revolution Direction (As Viewed From Pinion)		Clockwise	
Engagement System		Magnetic Shift	
No-load	Terminal Voltage / Current	11 V / 140 A max	
	Revolution	4100 rpm min	
Loaded	Terminal Voltage / Current	2.5 V / 1050 A max	
	Torque	18.1 ft lbs (24.5 N·m, 2.5 kgf·m) min	
Clutch System		Overrunning	
Pinion Projection Voltage at 212°F (100°C)		8.6 V max	
Pinion DP or Module / Number of Teeth		M3 / 9	
Difference (O-ring, Oil Seal)		Dry (none)	
Application		Standard	
Brush	Spring Force	7.868 lbf (35 N, 3.6 kgf)	
	Height	Standard	0.591 in (15 mm)
		Limit	0.354 in (9 mm)
Magnetic Switch	Series Coil Resistance	0.27 Ω at 68°F (20°C)	
	Shunt Coil Resistance	0.60 Ω at 68°F (20°C)	
Commutator	Outside Diameter	Standard	1.437 in (36.5 mm)
		Limit	1.398 in (35 mm)
	Run-Out	Standard	0.001 in (0.03 mm)
		Limit	0.008 in (0.2 mm)
	Insulation Depth	Standard	0.020 - 0.031 in (0.5 - 0.8 mm)
		Limit	0.008 in (0.2 mm)
Armature	Run-Out	Standard	0.001 in (0.03 mm)
		Limit	0.008 in (0.02 mm)
Bearing Type	Armature Front	Nominal Number	6903DDU
	Armature Rear		608DDU
	Pinion Front		60004DDU
	Pinion Rear		6904DDU
Pinion Projection Length (Length L)		0.012 - 0.059 in (0.3 - 1.5 mm)	

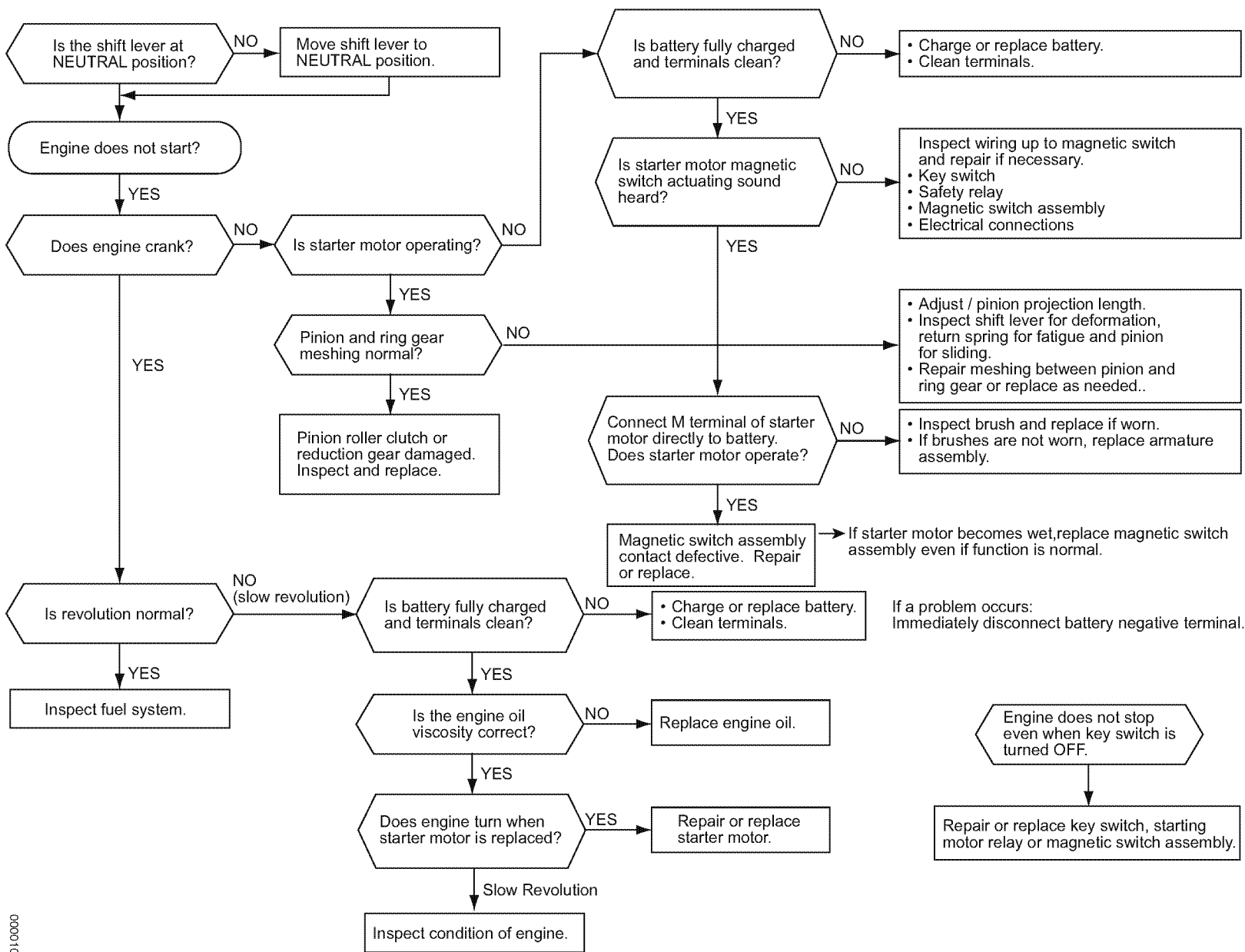

If a problem occurs: Immediately disconnect battery negative terminal.

If starter motor becomes wet, replace magnetic switch assembly even if function is normal.

0000102

## STARTER MOTOR PRECAUTIONS

Failure to follow these precautions may result in a loss of warranty coverage on a related item. Make sure that all users read and understand these precautions.

### **NOTICE**

- Make sure that the combined total resistance of the battery cable in both directions between the starter motor and the battery is within the value indicated on the wiring diagram. The starter motor will malfunction or break down if the resistance is higher than the specified value.
- The starter motor is water-proofed according to JIS D 0203, R2 which protects the motor from rain or general cleaning. Do not use high-pressure wash or submerge the starter motor in water.
- Use a specialized battery charger to recharge a battery with a voltage of 8 Volts or less. Booster starting a battery with a voltage of 8 Volts or less, will generate an abnormally high voltage and destroy electrical equipment.

# STARTER MOTOR

## STARTER MOTOR SERVICING

### Starter Motor Components

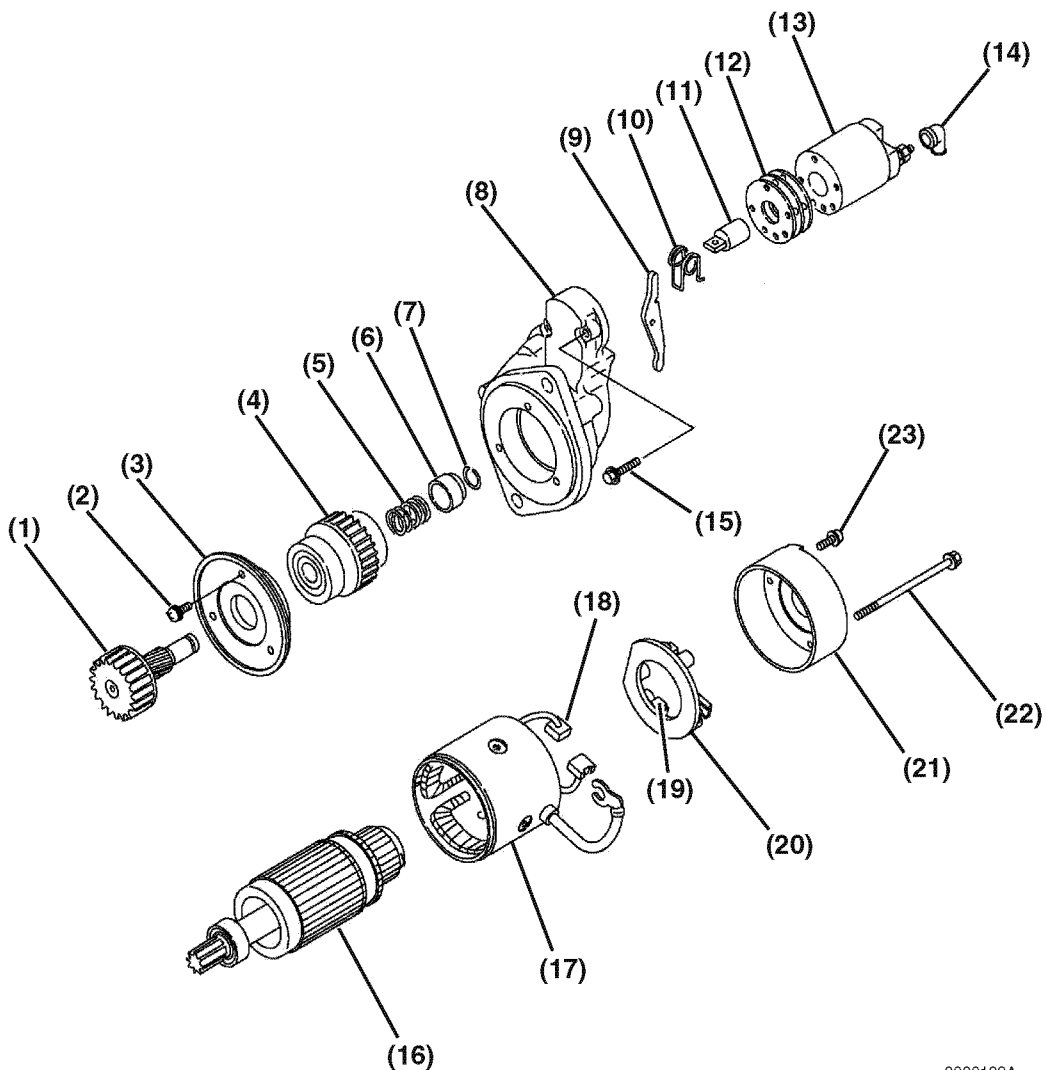

0000103A

**Figure 10-1**

- |                           |                         |                           |
|---------------------------|-------------------------|---------------------------|
| 1. Pinion Shaft           | 9. Shift Lever          | 16. Armature Assembly     |
| 2. M4 Bolts (3)           | 10. Torsion Spring      | 17. Field Coil Assembly   |
| 3. Bearing Retainer       | 11. Plunger             | 18. Positive (+) Brushes  |
| 4. Pinion Clutch Assembly | 12. Dust Covers (Shims) | 19. Negative (-) Brushes  |
| 5. Return Spring          | 13. Magnetic Switch     | 20. Brush Holder Assembly |
| 6. Pinion Stop            | 14. Cover               | 21. Rear Cover            |
| 7. Retaining Ring         | 15. M6 Bolts (2)        | 22. M5 Through Bolts (2)  |
| 8. Gear Housing           |                         | 23. M4 Bolts (2)          |

## Before You Begin

**⚠ WARNING****SEVER HAZARD!**

- Stop the engine before you begin to service it.

- NEVER leave the key in the key switch when you are servicing the engine. Someone may accidentally start the engine and not realize you are servicing it. This could result in a serious injury.
- If you must service the engine while it is operating, remove all jewelry, tie back long hair, and keep your hands, other body parts and clothing away from moving / rotating parts.
- Failure to comply could result in death or serious injury.

**⚠ WARNING****SHOCK HAZARD!**

- Turn off the battery switch (if equipped) or disconnect the negative battery cable before servicing the electrical system.

- Check the electrical harnesses for cracks, abrasions, and damaged or corroded connectors. ALWAYS keep the connectors and terminals clean.
- Failure to comply could result in death or serious injury.

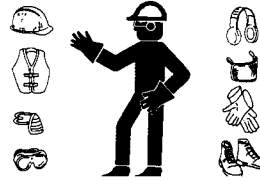
**⚠ WARNING****EXPOSURE HAZARD!**

- Always read and follow safety related precautions found on containers of hazardous substances like parts cleaners, primers, sealants, and sealant removers.
- Failure to comply could result in death or serious injury.

**⚠ CAUTION****FLYING OBJECT HAZARD!**

- ALWAYS wear eye protection when servicing engine and when using compressed air or high-pressure water. Dust, flying debris, compressed air, pressurized water or steam may injure your eyes.
- Failure to comply may result in minor or moderate injury.

# STARTER MOTOR

## Starter Motor Removal

### **WARNING**

#### **SHOCK HAZARD!**



- Turn off the battery switch (if equipped) or disconnect the negative battery cable before servicing the electrical system.

- Check the electrical harnesses for cracks, abrasions, and damaged or corroded connectors. **ALWAYS** keep the connectors and terminals clean.
- Failure to comply could result in death or serious injury.

1. Disconnect the battery cables at the battery.
2. Remove the electrical wires from the magnetic switch assembly
3. Remove the two M12 bolts (**Figure 10-2, (1)**) retaining the starter motor to the gear case. Remove the starter motor from the gear case.

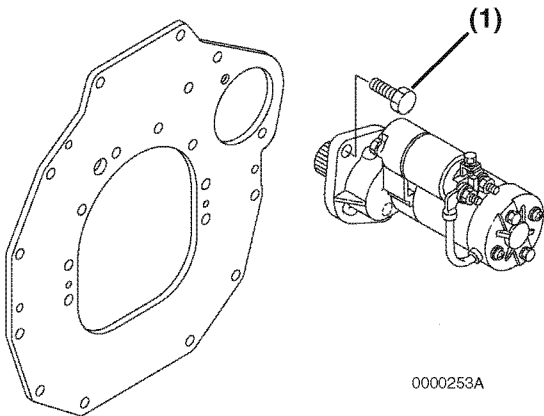

**Figure 10-2**

## Starter Motor Disassembly

1. Loosen the M8 nut from the magnetic switch assembly. Disconnect the wire from the magnetic switch.

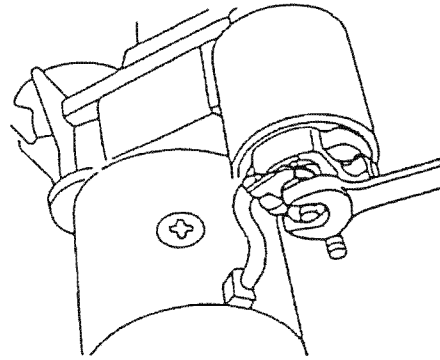

**Figure 10-3**

2. Remove the two M4 bolts (**Figure 10-4, (1)**) securing the rear cover (**Figure 10-4, (2)**) to the brush holder assembly (**Figure 10-4, (3)**).

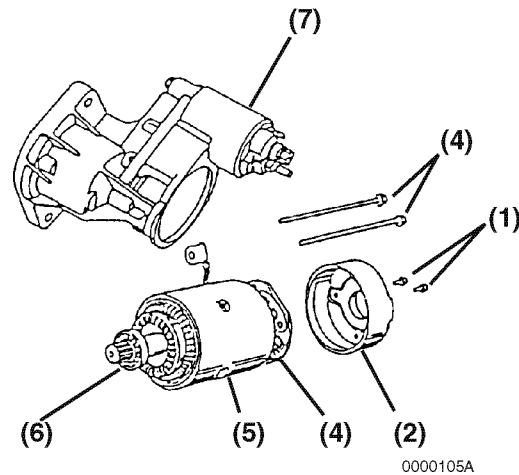

**Figure 10-4**

3. Remove the two M5 through bolts (**Figure 10-4, (4)**). Separate the rear cover (**Figure 10-4, (2)**), field coil assembly (**Figure 10-4, (5)**) with the armature assembly (**Figure 10-4, (6)**) from the gear housing (**Figure 10-4, (7)**).

- Pull the brush springs up using a brush spring puller. On the negative (-) side, bring the brush spring into contact with the side of the brush for lifting from the commutator surface. On the positive (+) side, remove the brush from the brush holder assembly **(Figure 10-5, (1))**.

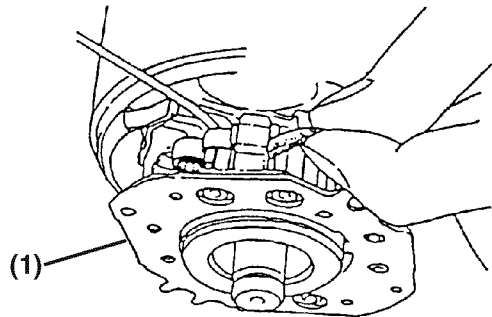

0000106A

**Figure 10-5**

- Remove the brush holder assembly **(Figure 10-6, (1))** from the armature assembly **(Figure 10-6, (3))**.

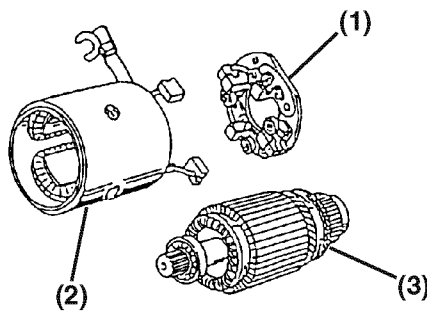

0000107A

**Figure 10-6**

- Pull the armature assembly **(Figure 10-6, (3))** out from the field coil assembly **(Figure 10-6, (2))**.
- Remove the two M6 bolts **(Figure 10-7, (1))** retaining the magnetic switch assembly **(Figure 10-7, (2))** to the gear housing. Remove the magnetic switch assembly, dust cover(s) **(Figure 10-7, (3))** and torsion spring **(Figure 10-7, (4))** from the gear housing.

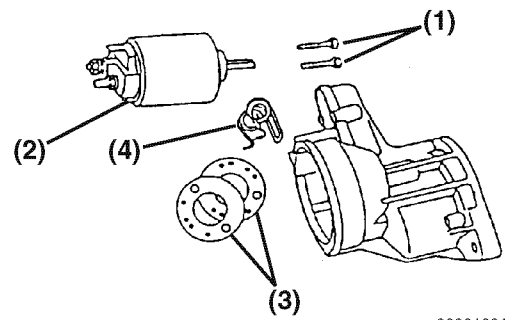

0000108A

**Figure 10-7**

- Disassemble the dust cover **(Figure 10-8, (3))** and shift lever **(Figure 10-8, (4))** from the gear housing.

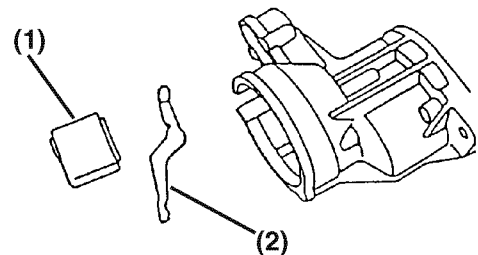

0000109A

**Figure 10-8**

- Remove the three M4 bolts **(Figure 10-9, (1))** securing the bearing retainer assembly **(Figure 10-9, (2))** to the gear housing. Remove the bearing retainer assembly from the gear housing.

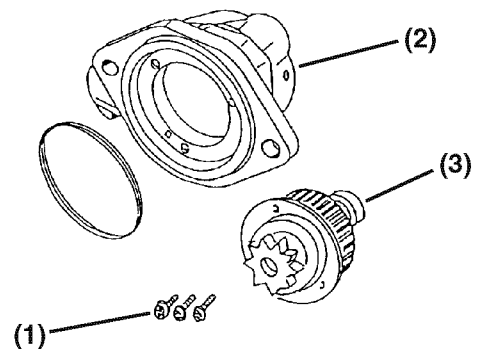

0000110A

**Figure 10-9**

- Remove the pinion clutch assembly **(Figure 10-9, (3))** from the bearing retainer assembly.

## STARTER MOTOR

- Using a flat-blade screwdriver, remove the retaining ring (**Figure 10-10, (1)**) from the shaft of the pinion.

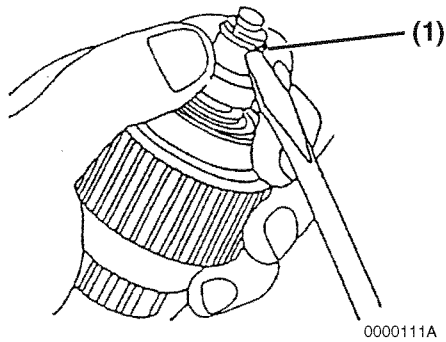

**Figure 10-10**

- Disassemble the pinion stop (**Figure 10-11, (2)**), return spring (**Figure 10-11, (4)**), pinion clutch assembly (**Figure 10-11, (1)**), and pinion shaft (**Figure 10-11, (5)**).

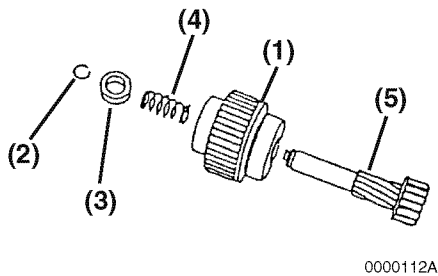

**Figure 10-11**

## Inspection

### Armature

#### **Commutator Surface Inspection**

If the commutator surface is rough, polish the surface with #500 to #600 emery cloth.

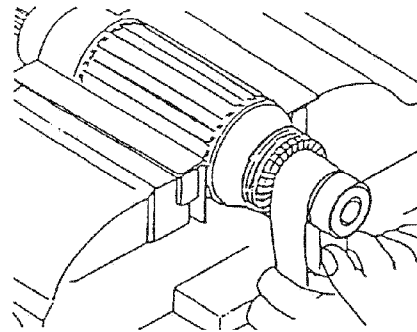
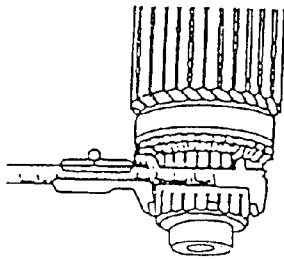

**Figure 10-12**



## Measure Commutator Outside Diameter

Measure the commutator outside diameter. Replace the armature if the measurement is less than the limit.



0000113

Figure 10-13

Standard	Limit
1.437 in (36.5 mm)	1.378 in (35 mm)

## Measure Commutator Insulation Depth

Measure the depth of the insulating material (Figure 10-14, (1)) between commutator segments (Figure 10-14, (2)). If the depth measures less than the limit, use a hacksaw blade (Figure 10-14, (3)) to remove the insulating material until the depth is within the limit.

A normal commutator condition is indicated in (Figure 10-14, (4)). An abnormal commutator condition is indicated in (Figure 10-14, (5)).

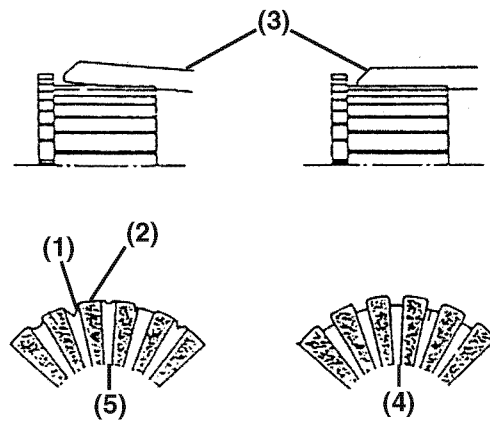

0000118

Figure 10-14

Standard	Limit
0.020 - 0.031 in (0.5 - 0.8 mm)	0.008 in (0.2 mm)

## Armature Coil Continuity Test

Check for continuity between the commutator segments using a multimeter. The multimeter should indicate continuity.

If the multimeter does not indicate continuity, replace the armature.

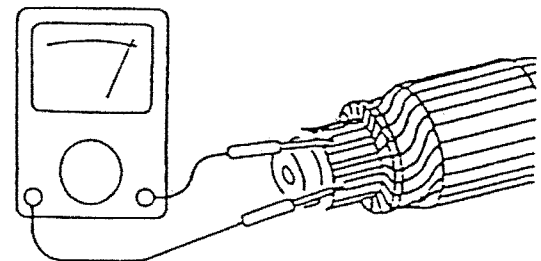

0000114

Figure 10-15

# STARTER MOTOR

## Armature Coil Insulation Test

Check for continuity between a commutator segment and the shaft or armature using a multimeter. The multimeter should not indicate continuity.

If the multimeter indicates continuity, replace the armature.

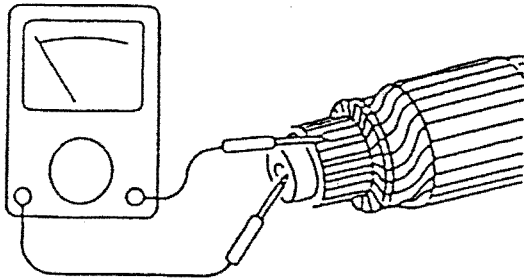

0000115

**Figure 10-16**

## Measure Armature and Commutator Run-Outs

Measure the armature core run-out and the commutator run-out using a dial indicator. Replace the armature if either of the measurements is less than the limit.

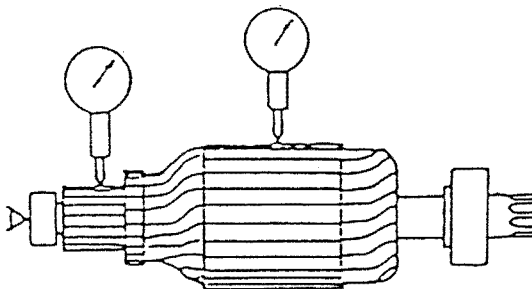

0000116

**Figure 10-17**

	Standard	Limit
Armature	0.001 in (0.03 mm)	0.008 in (0.2 mm)
Commutator	0.001 in (0.03 mm)	0.008 in (0.2 mm)

## Field Coil

### Field Coil Continuity Test

Check for continuity between the field coil terminals using a multimeter. The multimeter should indicate continuity.

If the multimeter does not indicate continuity, replace the field coil assembly.

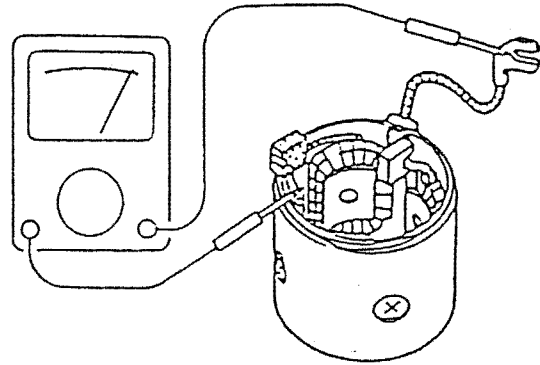

0000119

**Figure 10-18**

### Field Coil Insulation Test

Check for continuity between field coil terminal and yoke using a multimeter. The multimeter should not indicate continuity.

If the multimeter indicates continuity, replace the field coil assembly.

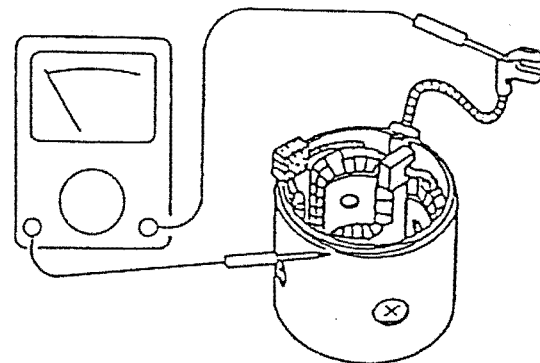

0000120

**Figure 10-19**

## Measure Brush Length

Measure the length of the brush. Replace the brush if the length is less than the limit.

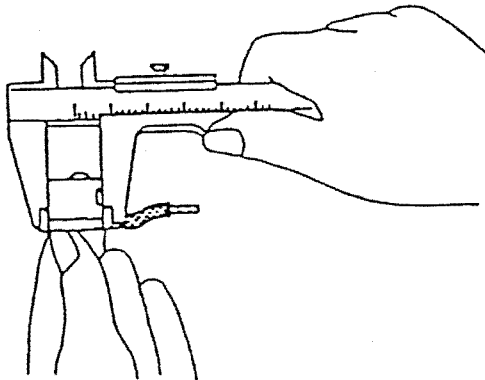

0000121

**Figure 10-20**

Standard	Limit
0.591 in (15 mm)	0.354 in (9 mm)

## Brush Holder

### Brush Holder Insulation Test

Check for continuity between each brush holder and the base using a multimeter. The multimeter should not indicate continuity.

If the multimeter indicates continuity, replace the brush holder.

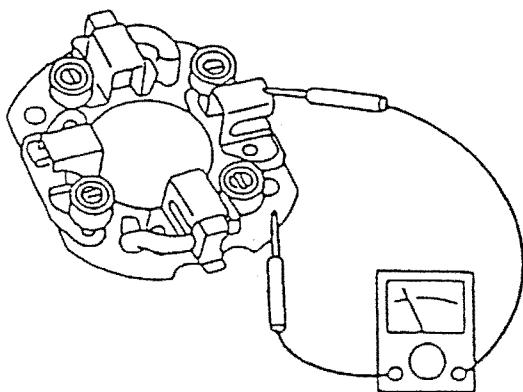

0000122

**Figure 10-21**

## Brush Spring Test

Test the spring force for each brush spring. Replace the brush spring if the force is not within the range.

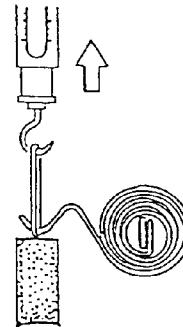

0000123

**Figure 10-22**

Standard
6.969 - 8.758 lbf (31 - 39 N, 3.1 - 3.9 kgf)

# STARTER MOTOR

## Magnetic Switch

If the starter motor becomes wet, replace the magnetic switch even if the magnetic switch assembly function is normal.

### Shunt Coil Continuity Test

Check for continuity between the “S” terminal and the switch body using a multimeter. The multimeter should indicate continuity.

If the multimeter does not indicate continuity, replace the magnetic switch.

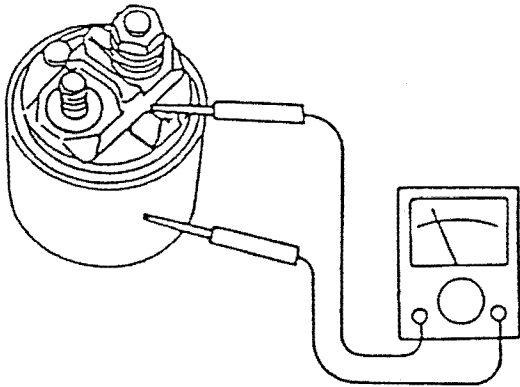

0000124

**Figure 10-23**

### Series Coil Continuity Test

Check for continuity between the “S” and “M” terminals using a multimeter. The multimeter should indicate continuity.

If the multimeter does not indicate continuity, replace the magnetic switch.

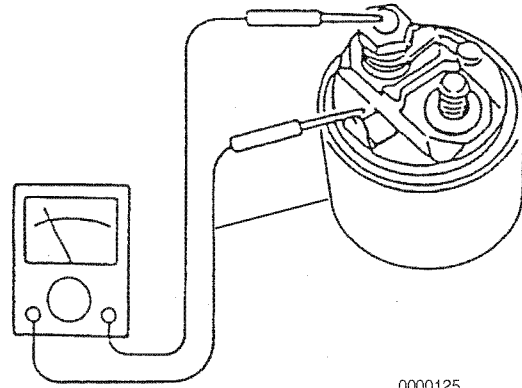

0000125

**Figure 10-24**

### Coil Resistance Test

Test	Resistance at 68°F (20°C)
Series Coil	0.27 $\Omega$
Shunt Coil	0.6 $\Omega$

## Contact Continuity Test

Depress the plunger at the bottom of the magnetic switch. Check for continuity between the "B" and "M" terminals using a multimeter. The multimeter should indicate continuity.

If the multimeter does not indicate continuity, replace the magnetic switch.

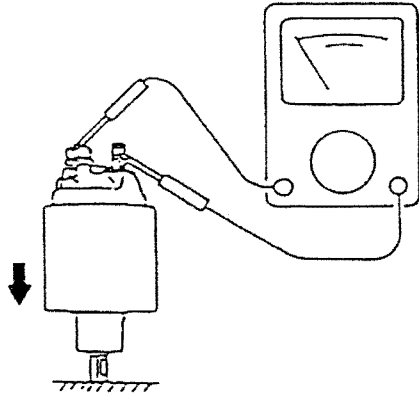

0000126

**Figure 10-25**

## Pinion Clutch Assembly

### Pinion Clutch Assembly Inspection

Manually rotate the pinion clutch assembly in the drive direction. It should rotate freely in the drive direction and locked in the opposite direction. Replace the pinion clutch assembly if the results are different.

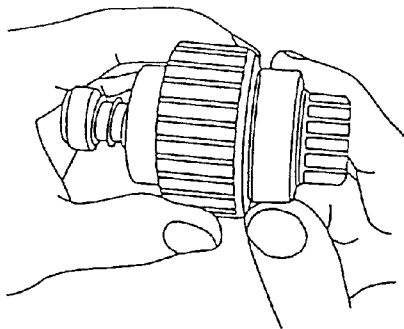

0000127

**Figure 10-26**

Slide the pinion clutch assembly on the shaft. It should slide smoothly on the shaft. Rust, too much grease or damage could prevent the pinion clutch from sliding smoothly. If the pinion clutch assembly does not slide smoothly, clean the shaft and pinion clutch assembly or replace the damaged component.

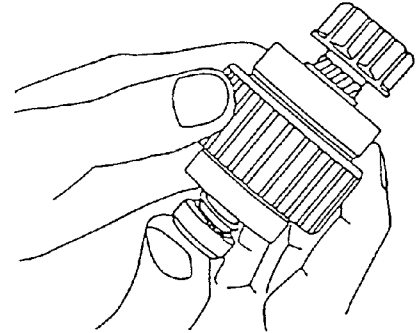

0000128

**Figure 10-27**

### Ball Bearing Inspection

Rotate each ball bearing while holding the pinion clutch assembly. Replace the ball bearing if it does not rotate smoothly or has excessive play.

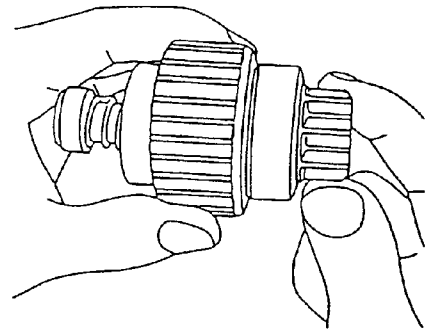

0000129

**Figure 10-28**

# STARTER MOTOR

## Starter Motor Assembly

1. Apply NPC-FC6A grease to the pinion shaft. Assemble the pinion shaft (**Figure 10-29, (5)**), pinion clutch assembly (**Figure 10-29, (1)**), return spring (**Figure 10-29, (4)**) and pinion stop (**Figure 10-29, (3)**). Install the retaining ring (**Figure 10-29, (2)**) in groove in the pinion shaft. Slide the piston stop over the retaining ring.

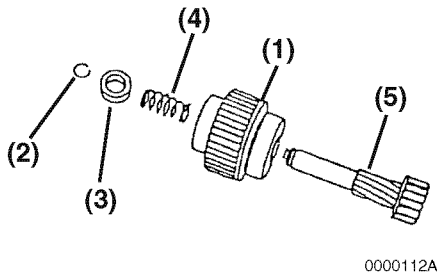

**Figure 10-29**

2. Install the pinion clutch assembly into the bearing retainer assembly.
3. Install the bearing retainer assembly and pinion assembly to the gear housing. Install and tighten the three M4 bolts.
4. Apply NFC-F6A grease to the sliding portions of the shift lever (**Figure 10-30, (1)**). Assemble the torsion spring (**Figure 10-30, (2)**), shift lever and dust cover(s) (**Figure 10-30, (3)**), plunger (**Figure 10-30, (4)**) and magnetic switch assembly (**Figure 10-30, (5)**).

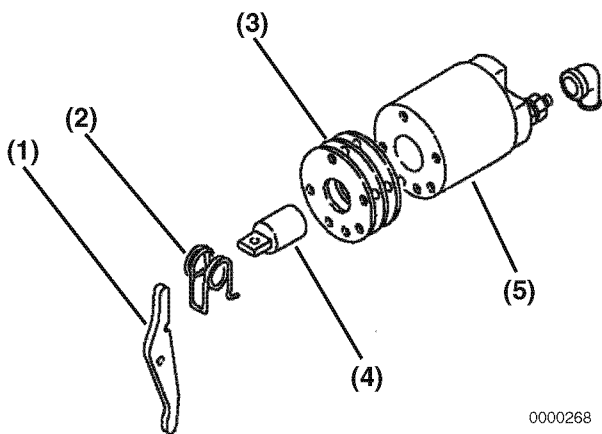

**Figure 10-30**

5. Assemble the magnetic switch assembly to the gear housing. Pry the pinion away from the gear housing to allow installation of the magnetic switch assembly.

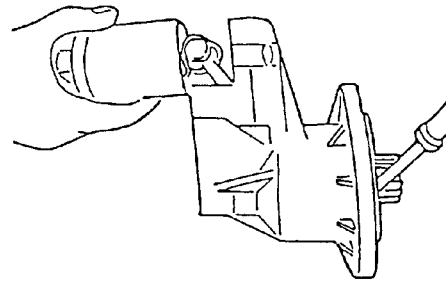

**Figure 10-31**

6. Secure the magnetic switch assembly to the gear housing using the two M6 bolts.
7. Carefully install the armature assembly (**Figure 10-32, (1)**) into the field coil assembly (**Figure 10-32, (2)**).

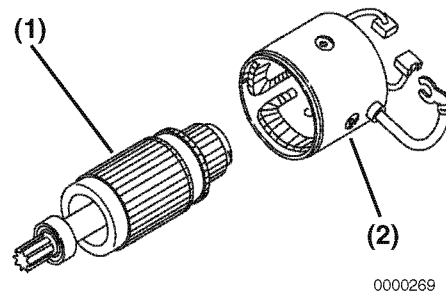

**Figure 10-32**

- Position the brush springs in brush holders. Install the brushes in the brush holders. Reversing the brushes in will cause the starter motor to turn backwards.

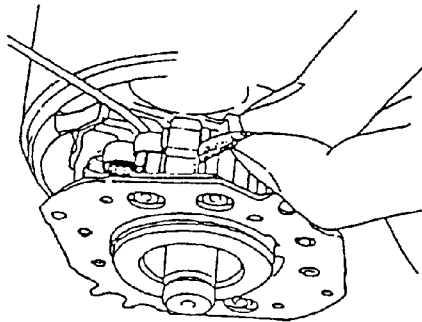

0000106

**Figure 10-33**

- Carefully install the brush holder assembly to the armature assembly.
- Install the field coil assembly with the armature assembly to the gear housing.
- Install the rear cover to the brush holder assembly. Securely tighten the two bolts.
- Install the two M4 through bolts. Tighten the through bolts to the specified torque.
- Connect the wire to the magnetic switch assembly. Tighten the M8 nut. Install the cover over the connection.

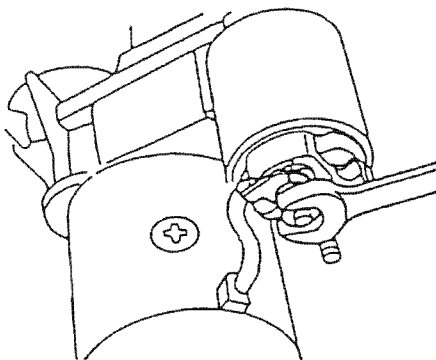

0000104

**Figure 10-34**

## Check Pinion Projection Length

- Connect the positive (+) lead from a battery to the "S" terminal.
- Connect the negative (-) lead to the "M" terminal.
- Lightly pull the pinion out away from the gear housing.
- Turn the switch ON and measure the pinion moving distance L in the thrust direction. Perform this test within 10 seconds.

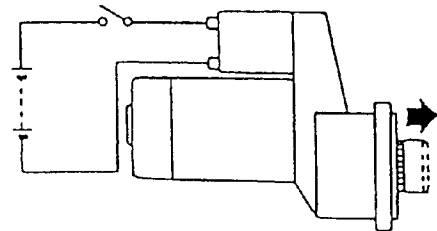

0000132

**Figure 10-35**

	Standard
L	0.012 - 0.059 in (0.3 to 1.5 mm)

- If the measured L dimension is outside the standard range, adjust the dust covers to obtain the standard range. Dust covers (**Figure 10-36, (1)**) are available in 0.020 in (0.5 mm) and 0.031 in (0.8 mm) thicknesses.

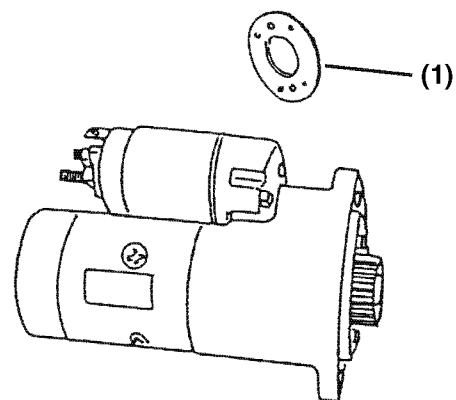

0000133

**Figure 10-36**

# STARTER MOTOR

## No Load Test

Test the characteristics of the starter motor by performing a no load test.

### NOTICE

The starter motor can be damaged if operated continuously longer than 30 seconds while performing the no load test.

1. Secure the starting motor in a vise or other suitable fixture.
2. Connect an ammeter (**Figure 10-37, (1)**) in series with the battery positive (+) terminal (**Figure 10-37, (2)**) and the "S" terminal (**Figure 10-37, (3)**) of the starter motor solenoid.
3. Connect a voltmeter (**Figure 10-37, (4)**) between the solenoid "M" terminal and the frame of the starter motor.
4. Attach a tachometer in the current or hold a vibration tachometer against the starter motor.
5. Attach a switch in the current.
6. Turn the switch to the ON position. Observe the starter rpm, amperage draw and voltage readings. See no load specifications in the chart below.

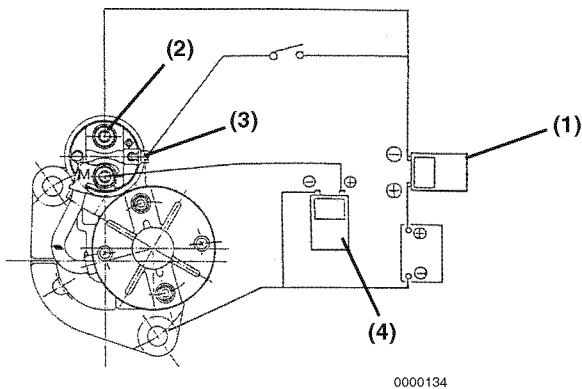
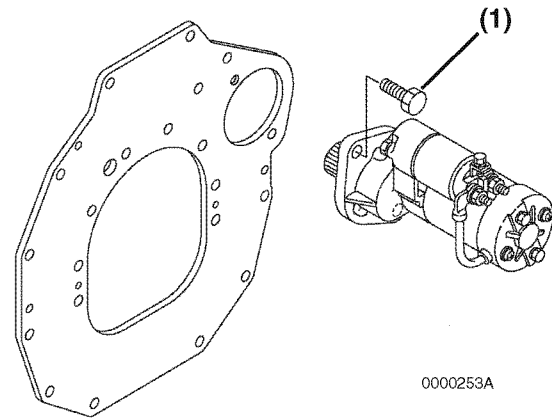

**Figure 10-37**

Terminal Voltage / Current	11 V / 140 A max
Revolution	4100 rpm min

## Starter Motor Installation

1. Install the starter motor to the gear case.
2. Install the two M12 bolts (**Figure 10-38, (1)**). Tighten the bolts to the specified torque.



**Figure 10-38**

3. Reconnect the electrical wires to the magnetic switch assembly. Be sure to place the cover over the battery positive (+) cable connection.
4. Reconnect the battery cables at the battery.



## Section 11

# ALTERNATOR

---

## Table of Contents

	Page
Alternator Service Information .....	11-3
Alternator Troubleshooting .....	11-4
Alternator Precautions .....	11-5
Alternator Components .....	11-6
Alternator Servicing .....	11-7
Before You Begin Servicing.....	11-7
Removal of Alternator.....	11-8
Disassembly of Alternator.....	11-8
Inspection .....	11-11
Assembly of Brush Holder .....	11-16
Assembly of Alternator .....	11-18
Installation of Alternator.....	11-19
Bench Test .....	11-20

**This Page Intentionally Left Blank**

This section of the Service Manual describes the servicing of the alternator.

## ALTERNATOR SERVICE INFORMATION

Yanmar Part Number	129423-77200
Rating	Continuous
Battery Voltage	12 Volts
Nominal Output (12 Volts Heat)	40 Amps
No Load Test Maximum rpm	1350 rpm (min <sup>-1</sup> )
Output Test Minimum Current (Cool)	13.5 V@ 5000 rpm (min <sup>-1</sup> )
Grounding Characteristics	Negative (-) Side of Circuit
Direction of Revolution (Viewed from Pulley)	Clockwise
Rotor Coil Resistance	2.9 Ohms
Outside Diameter of Pulley	2.7 in (69.2 mm)
Brush Length	Standard 0.41 in (10.5 mm)
	Limit 0.33 in (8.4 mm)

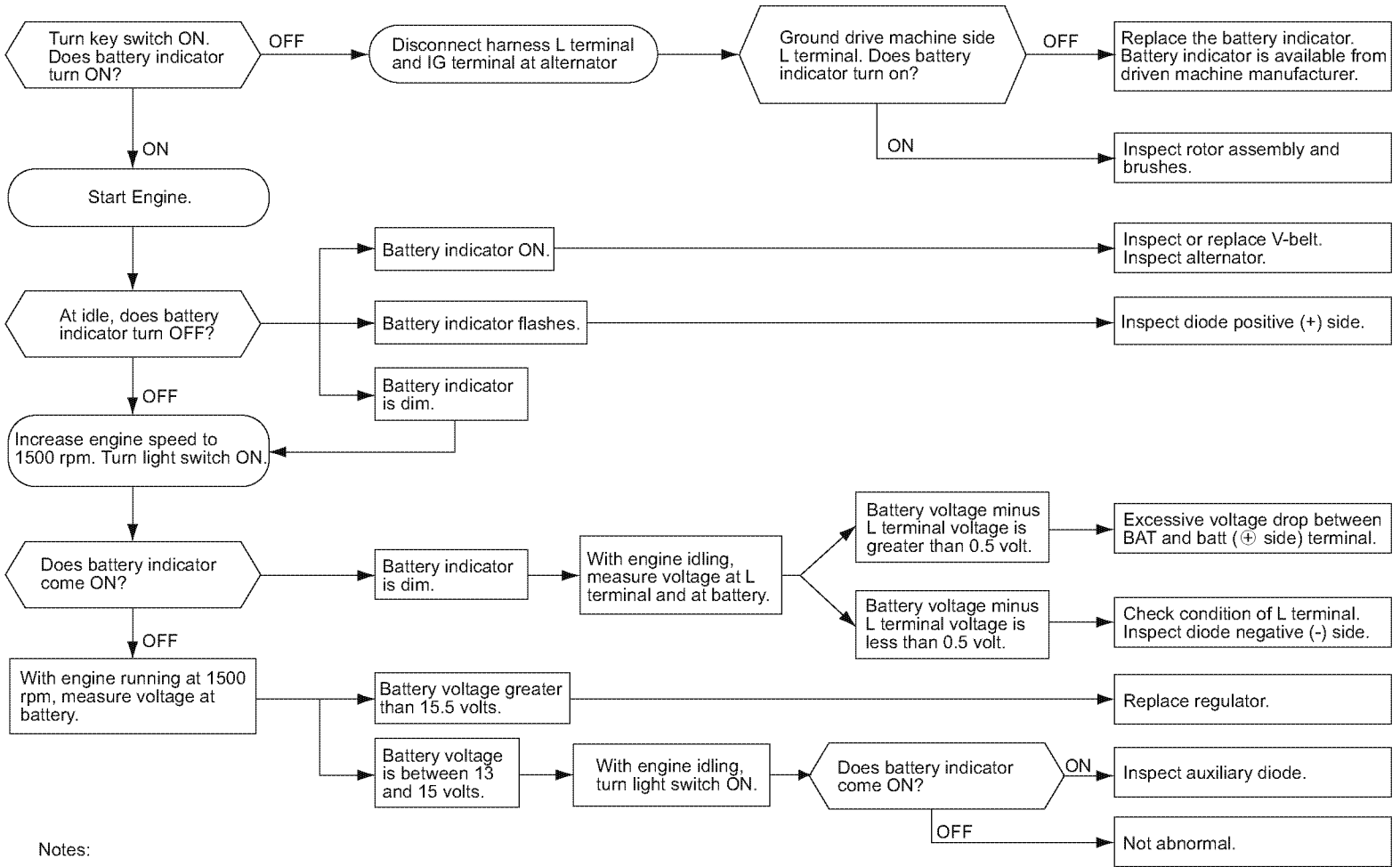

Notes:

- 1) Use a fully charged battery
- 2) DC voltmeter: 0 to 30 V, 0.5 class
- 3) The check method is also applicable to the bench test

0001666

## ALTERNATOR PRECAUTIONS

Failure to follow these precautions may result in a loss of warranty coverage on a related item. Make sure that all users read and understand these precautions.

### NOTICE

- Do not turn the battery switch OFF while the engine is operating. Damage to the alternator will result.
- Do not reverse the positive and negative ends of the battery cable. The alternator diode and stator coil will be damaged.
- When the battery indicator goes out, it should not come on again. The battery indicator only comes on during operation if the alternator fails or if the V-belt breaks. However, if an LED is used in the battery indicator, the LED will shine faintly during normal operation.
- Using a non-specified V-belt will cause inadequate charging and shorten the belt life. Use the specified belt.
- Do not use a high pressure wash directly on the alternator. Water will damage the alternator and result in inadequate charging.
- Agricultural or other chemicals, especially those with a high sulfur content, can adhere to the IC regulator. This will corrode the conductor and result in battery over-charging (boiling) and charging malfunctions. Consult Yanmar before using the equipment in such an environment or the warranty is voided.

# ALTERNATOR

## ALTERNATOR COMPONENTS

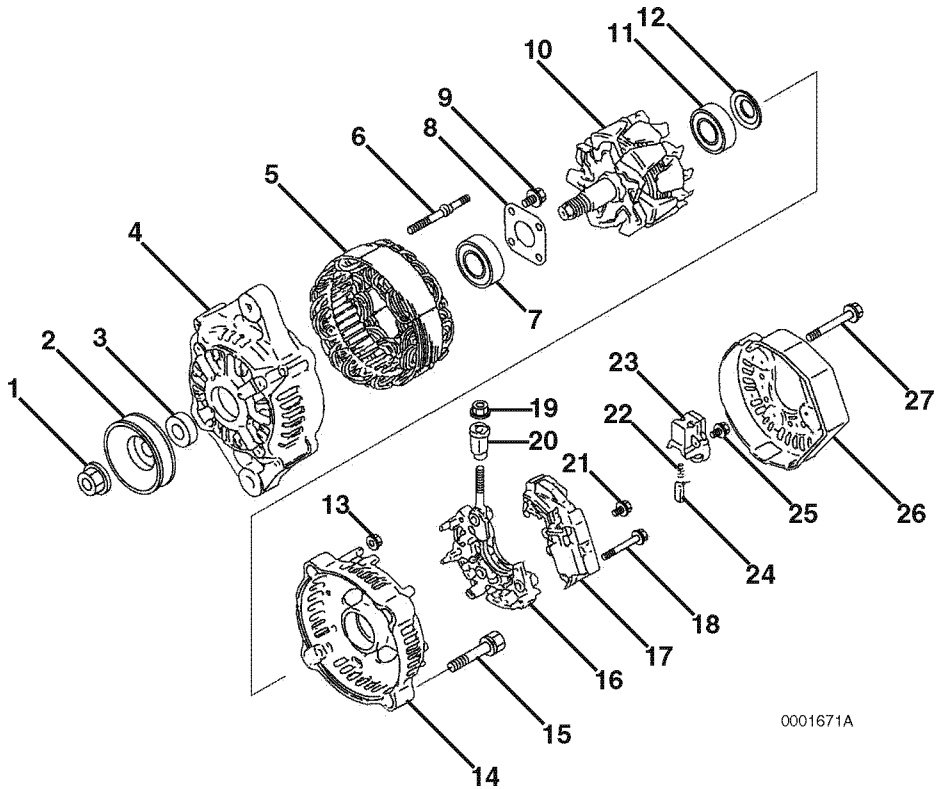

**Figure 11-1**

- |                                |                           |
|--------------------------------|---------------------------|
| 1. Nut                         | 15. Bolt (2)              |
| 2. Pulley                      | 16. Holder                |
| 3. Collar                      | 17. IC Regulator Assembly |
| 4. Front Frame Housing         | 18. Bolt (2)              |
| 5. Stator Assembly             | 19. Nut                   |
| 6. Stud (2)                    | 20. Insulation Bushing    |
| 7. Front Frame Housing Bearing | 21. Bolt                  |
| 8. Bearing Cover               | 22. Spring (2)            |
| 9. Bearing Cover Bolt (4)      | 23. Brush Holder          |
| 10. Rotor Assembly             | 24. Brush (2)             |
| 11. Rear Frame Housing Bearing | 25. Bolt                  |
| 12. Thrust Washer              | 26. Rear Cover            |
| 13. Nut (2)                    | 27. Bolt (3)              |
| 14. Rear Frame Housing         |                           |

## ALTERNATOR SERVICING

### Before You Begin Servicing

#### ⚠ WARNING

##### SEVER HAZARD!



- Stop the engine before you begin to service it.

- NEVER leave the key in the key switch when you are servicing the engine. Someone may accidentally start the engine and not realize you are servicing it. This could result in a serious injury.
- If you must service the engine while it is operating, remove all jewelry, tie back long hair, and keep your hands, other body parts and clothing away from moving / rotating parts.
- Failure to comply could result in death or serious injury.

#### ⚠ WARNING

##### BURN HAZARD!



- Keep your hands, and other body parts, away from hot engine surfaces such as the muffler, exhaust pipe, turbocharger (if equipped) and engine block during operation and shortly after you shut the engine down. These surfaces are extremely hot while the engine is operating and could seriously burn you.

- Failure to comply could result in death or serious injury.

#### ⚠ WARNING

##### EXPOSURE HAZARD!

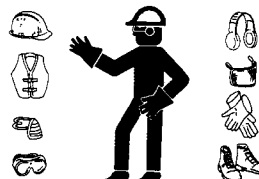

- Always read and follow safety related precautions found on containers of hazardous substances like parts cleaners, primers, sealants, and sealant removers.

- Failure to comply could result in death or serious injury.

#### ⚠ CAUTION

##### FLYING OBJECT HAZARD!



- ALWAYS wear eye protection when servicing engine and when using compressed air or high-pressure water. Dust, flying debris, compressed air, pressurized water or steam may injure your eyes.

- Failure to comply may result in minor or moderate injury.

#### NOTICE



NEVER permit anyone to operate the engine or driven machine without proper training.

- Read and understand this Operation Manual before you operate the machine to ensure that you follow safe operating practices and maintenance procedures.
- Machine safety signs and labels are additional reminders for safe operating and maintenance techniques.
- See your authorized Yanmar industrial engine dealer or distributor for additional training.

# ALTERNATOR

## Removal of Alternator

### ⚠ WARNING

#### SHOCK HAZARD!



- Turn off the battery switch (if equipped) or disconnect the negative battery cable before servicing the electrical system.

- Check the electrical harnesses for cracks, abrasions, and damaged or corroded connectors. ALWAYS keep the connectors and terminals clean.
- Failure to comply could result in death or serious injury.

### NOTICE

Do not use a high pressure wash directly on the alternator. Water will damage the alternator and result in inadequate charging.

1. Disconnect the electrical wires from the alternator.
2. Loosen the V-belt.

### ⚠ CAUTION

#### PINCH HAZARD!

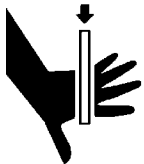

Carefully rotate the alternator toward the cylinder block while loosening the V-belt. Failure to comply may result in minor or moderate injury.

3. Remove the V-belt adjuster to alternator bolt (Figure 11-2, (1)).
4. Remove the nut (Figure 11-2, (2)) and bolt (Figure 11-2, (3)) from the gearcase. Remove the alternator.

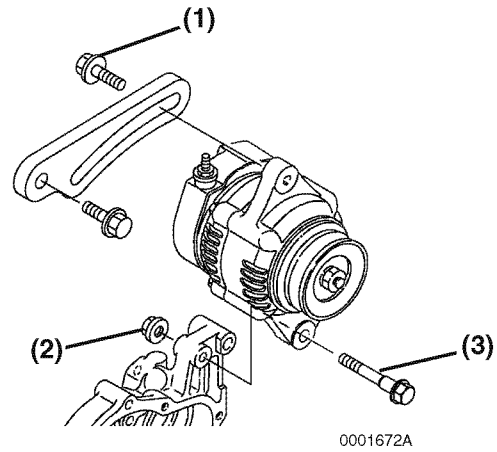

Figure 11-2

## Disassembly of Alternator

1. Remove the nut (Figure 11-3, (1)) from the shaft of the rotor assembly. Remove the pulley (Figure 11-3, (2)).

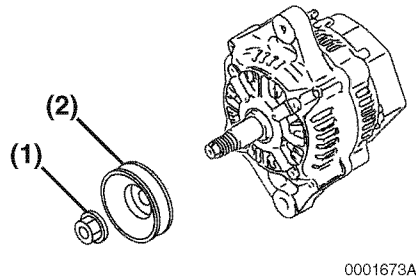
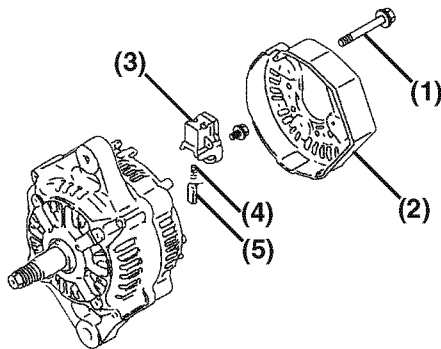

Figure 11-3

2. Remove the three bolts (Figure 11-4, (1)) retaining the rear cover (Figure 11-4, (2)) to the rear frame assembly and the nut securing terminal B.





0001674A

**Figure 11-4**

3. Remove the brush holder (**Figure 11-4, (3)**). Remove the brush springs (**Figure 11-4, (4)**) and brushes (**Figure 11-4, (5)**).
4. Remove the three bolts retaining the regulator assembly (**Figure 11-5, (1)**) to the holder (**Figure 11-5, (2)**).

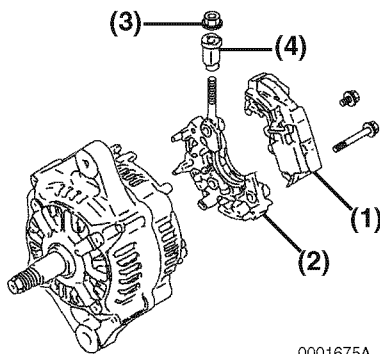

0001675A

**Figure 11-5**

Note: Retain the bolts for reassembly.

## NOTICE

If bolts of incorrect length are used for reassembly, the bolts may contact the rear frame which will cause loss of regulator control. An excessive amount of voltage could be applied to the battery, resulting in serious battery malfunction.

5. Remove the bolts retaining the holder (**Figure 11-5, (2)**) to the rear frame housing. Remove the holder.

6. Remove the nuts (**Figure 11-5, (3)**) retaining the insulation bushing (**Figure 11-5, (4)**). Remove the insulation bushing.

## NOTICE

Be careful not to stretch the stator wires when removing the bushing. Damage to the stator can result.

7. Remove the four bolts (**Figure 11-6, (1)**) and four nuts (**Figure 11-6, (2)**) securing the rear frame housing to the front frame housing.

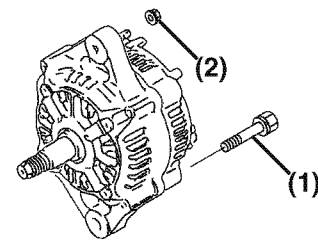

0001676A

**Figure 11-6**

8. Before disassembling the stator from the front frame housing, scratch a positioning line (**Figure 11-7, (3)**) on the housing in alignment with the lead wire (**Figure 11-7, (1)**) positioning. Make sure that the positioning line does not deviate more than  $\pm 0.02$  in ( $\pm 0.5$  mm).  
If installing a new stator, align the new stator with the old stator position mark (**Figure 11-7, (3)**). Make sure that the new and old stator positioning lines do not deviate more than  $\pm 0.02$  in ( $\pm 0.5$  mm).

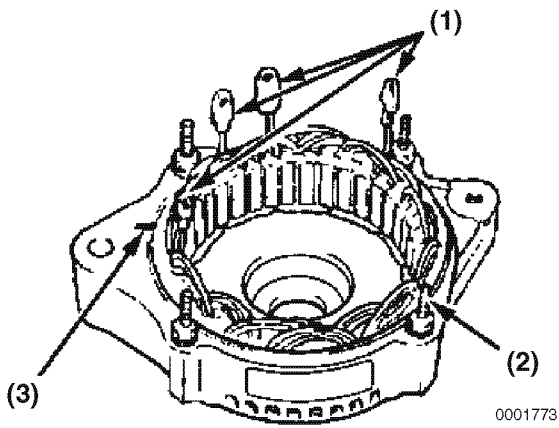

**Figure 11-7**

9. If replacing the front frame housing, scratch two positioning lines (**Figure 11-8, (1)**) on the stator before disassembly. Make sure that the positioning lines do not deviate more than  $\pm 0.04$  in ( $\pm 1$  mm). If positioning deviates, the stator lead wire cannot be connected to the rectifier.

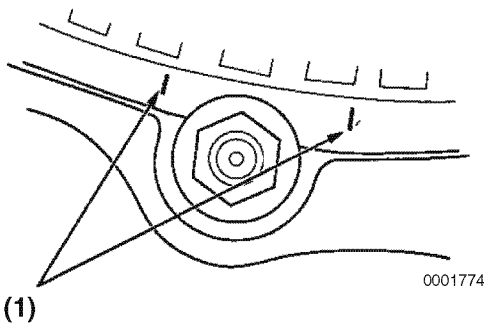

**Figure 11-8**

10. Using a press, remove the rotor assembly (**Figure 11-9, (1)**) from the front frame housing (**Figure 11-9, (2)**) and rear frame housing (**Figure 11-10, (1)**).

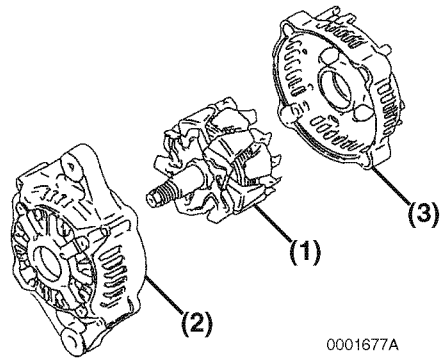
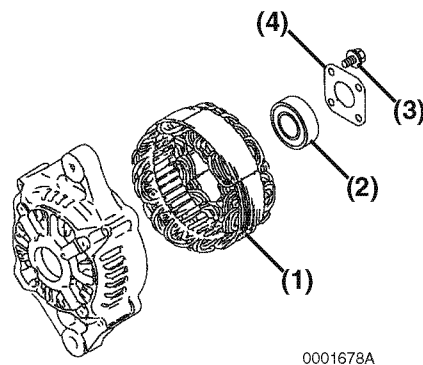

**Figure 11-9**

## NOTICE

Be careful not to drop the rotor. Damage to the slip rings or fan can result.

11. Remove the stator assembly (**Figure 11-10, (1)**) from the front frame housing.



**Figure 11-10**

12. If necessary to replace the bearing (**Figure 11-10, (2)**) in the front frame housing, remove the four bolts (**Figure 11-10, (3)**) securing the plate (**Figure 11-10, (4)**) to the front frame housing. Remove the plate. Use a puller to remove the bearing. Discard the bearing.

13. If necessary to replace the bearing (Figure 11-11, (1)) in the rear frame housing, use a puller to remove. Discard the bearing and thrust washer (Figure 11-11, (2)).

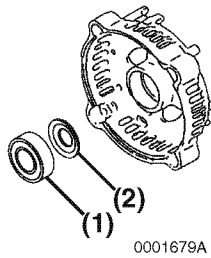

Figure 11-11

## Inspection

### Stator Coil

#### Stator Coil Continuity Test

Measure the resistance value at each of the coil terminals using a multimeter (Figure 11-12, (1)).

Standard Value	1Ω or less
----------------	------------

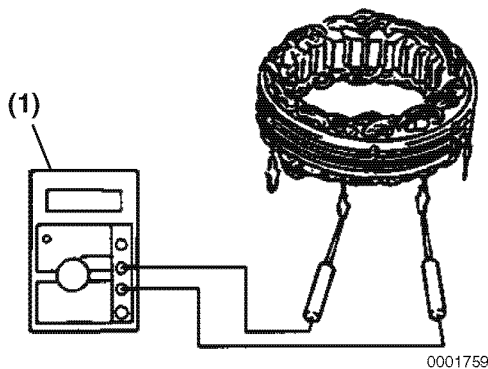

Figure 11-12

#### Stator Coil Insulation Test

Check the insulation between the coil terminal and the core using a 500 V Megger tester (Figure 11-13, (1)).

Standard Value	0.1Ω or more
----------------	--------------

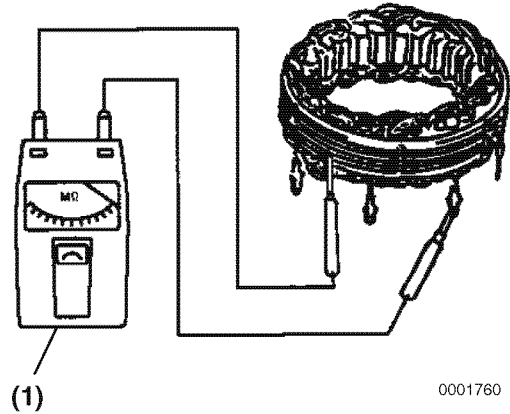

Figure 11-13

### Rotor

#### Slip Ring Surface Inspection

If the slip ring surfaces are rough or dirty, polish the surfaces with #300 to #500 emery cloth.

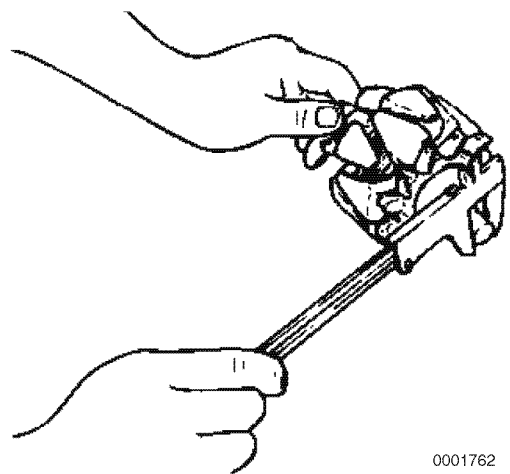

Figure 11-14

# ALTERNATOR

## Slip Ring Resistance Test

Measure the resistance value at the slip rings using a multimeter.

Standard Value	1Ω or less
----------------	------------

## Slip Ring Insulation Test

Check the insulation between the rotor core (Figure 11-15, (1)) and the slip rings (Figure 11-15, (2)) using a 500 V Megger tester (Figure 11-15, (3)).

Standard Value	0.1Ω or more
----------------	--------------

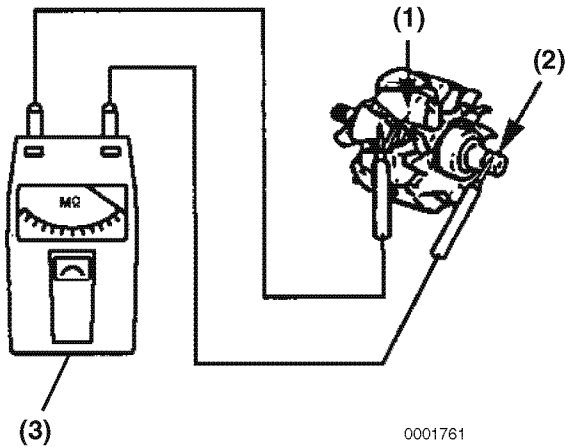

Figure 11-15

## Slip Ring Diameter Inspection

Measure the outer diameter of the rotor slip rings.

Standard Value	0.567 in (14.4 mm)
Replacement Standard	0.551 in (14.0 mm)

## Rectifier

Check for continuity using a multimeter set in the K range (Figure 11-16, (3)).

### NOTICE

NEVER use a 500 V Megger tester to test the rectifiers. The rectifier will be destroyed.

Continuity should only exist in one direction.

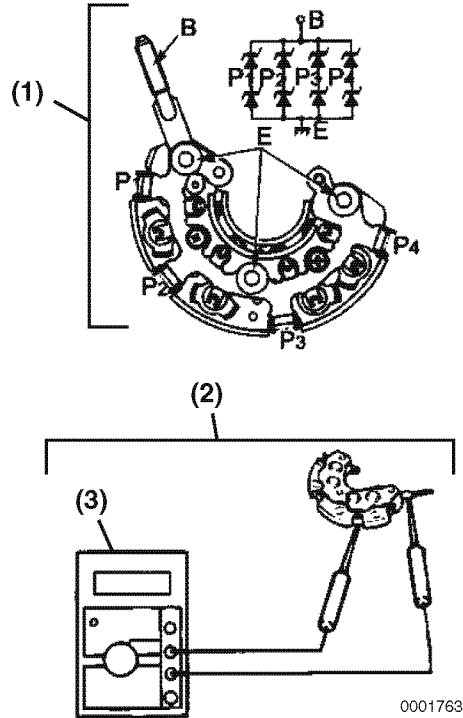

Figure 11-16

Item	Description
1	Circuit
2	Inspection

### NOTICE

The rectifier cannot be judged good or bad based solely on the correct direction resistance value. Judgement is made according to the high and low resistance values.

**IC Regulator**

The following instructions are for the M1 type IC regulator.

**Wiring Diagram**

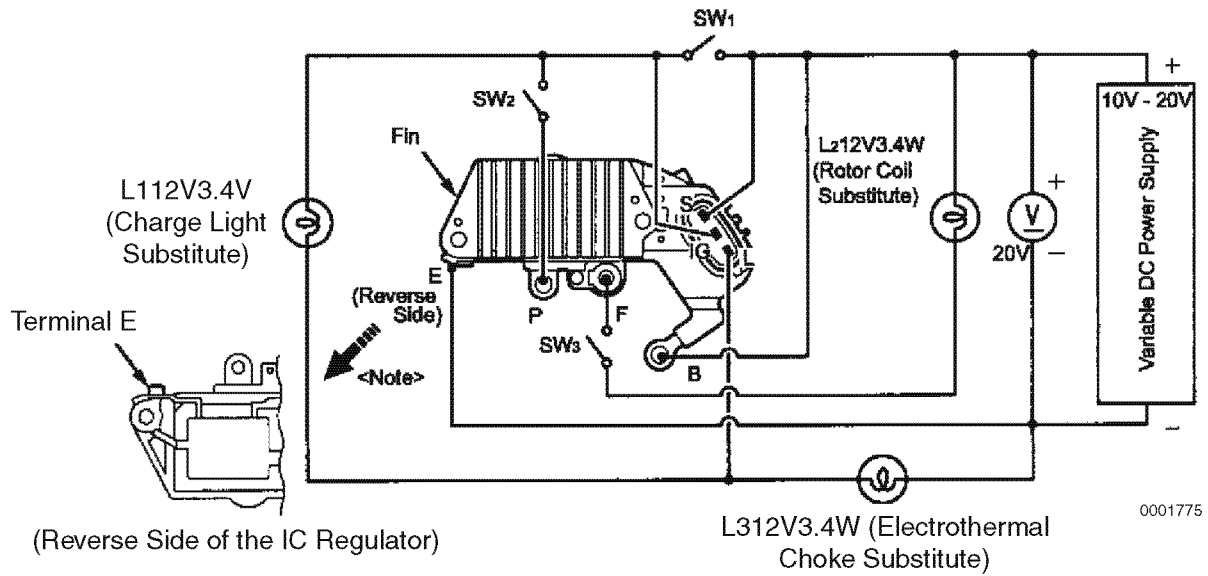

Figure 11-17

**Work Procedures and OK/NG Judgement Standards**

No.	Procedure	Voltage	Indicator	Remarks
1	Connection			
2	Set the variable DC power supply to 12 V. Set SW1 and SW2 to OFF and SW3 to ON.			
3	Turn SW1 ON (key switch ON).	12 V	L1: ON.	Charge light ON.
			L2: ON dimly.	Initial excitation.
			L3: OFF.	
4	Turn SW2 ON (during engine operation).	12 V	L1: OFF.	Charge light inspection.
			L2: ON.	Power generation inspection.
			L3: ON.	Electrothermal choke actuation inspection.
5	Switch SW1 and SW2 ON, gradually increase voltage from 12 V.	14.5 ± 0.6 V	L1: OFF.	
			L2: OFF.	Regulated voltage inspection.
			L3: ON.	
6	Return voltage to 12 V.	12 V	L3: ON	
			L2: ON.	
			L3: ON.	

# ALTERNATOR

No.	Procedure	Voltage	Indicator	Remarks
<b>Additional Functions</b>				
7	Perform operation 5 and gradually increase voltage with SW1 and SW2 ON and SW3 OFF.	16.5 ± 1.0 V	L1: ON.	Excessive Voltage Warning.
			L2: OFF.	
			L3: OFF.	
8	With SW1 and SW2 ON, turn SW3 on and gradually decrease voltage from 12 V.	10 V or less	L1: ON.	Low voltage warning.
			L2: ON.	
			L3: ON.	
9	Return voltage to 12 V and disconnect terminal S.	12 V	L1: ON.	Terminal S disconnection warning.
			L2: ON.	
			L3: OFF.	
10	Test the diode (refer to <i>Diode on page 11-15</i> ).			

**Diode**

Check for continuity between terminals B and F using a multimeter (**Figure 11-18, (1)**).

1. Disconnect the diode wiring between terminals B and F.
2. Set the multimeter in the XΩ range and measure continuity between terminals B and F. The multimeter should indicate continuity.
3. Switch the polarity between terminals B and F and measure continuity again. The multimeter should not indicate continuity.

Note: Measure in the diode measurement range on an analog or digital multimeter.

If the multimeter does not indicate continuity or indicates continuity in both directions, replace the diode.

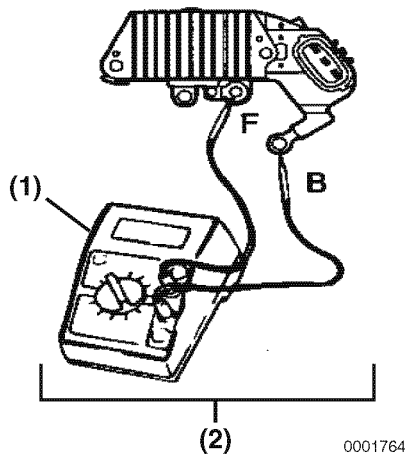
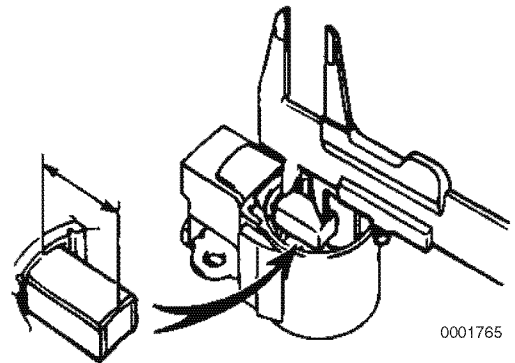

**Figure 11-18**

Item	Description
1	Multimeter
2	Diode Inspection

**Brush**

Measure the length of the brush protruding from the brush holder (**Figure 11-19**).



**Figure 11-19**

Standard Value	0.41 in (10.5 mm)
Replacement Standard	0.33 in (8.4 mm)

# ALTERNATOR

## Assembly of Brush Holder

Note: Some types of brush holders do not have a cover.

1. Insert the brush holder (**Figure 11-20, (4)**) tab (**Figure 11-20, (1)**) into the groove (**Figure 11-20, (2)**) in the holder cover (**Figure 11-20, (3)**).

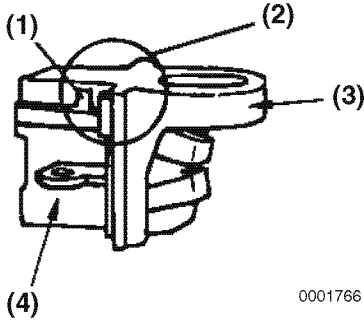

**Figure 11-20**

Note: **Figure 11-21** shows a brush holder installed incorrectly. The tab is detached from the groove (**Figure 11-21, (1)**).

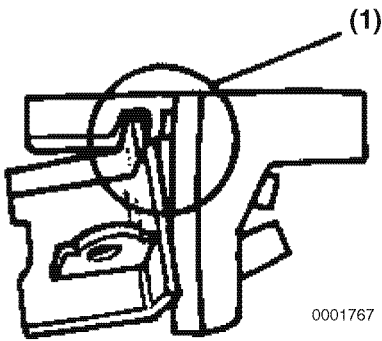

**Figure 11-21**

Note: The brush holder must be assembled before the IC Regulator is assembled to the alternator.

2. Install the brush holder (**Figure 11-22, (1)**) to the IC Regulator (**Figure 11-22, (4)**).

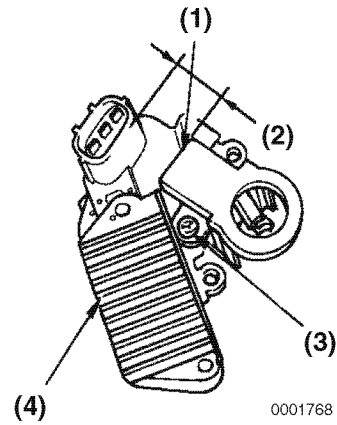

**Figure 11-22**

3. Maintain a gap of 0.047 in (1.2 mm) or more as shown (**Figure 11-22, (2)**).
4. Tighten the interior bolt (**Figure 11-22, (3)**).
5. Make sure that the housing fits into the groove (**Figure 11-23, (2)**) on the reverse side of the brush holder cover (**Figure 11-23, (1)**).

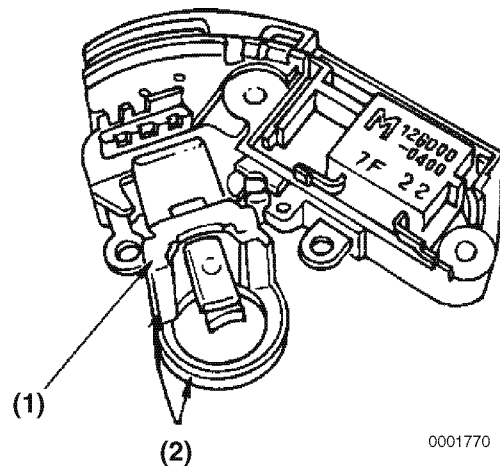

**Figure 11-23**

### NOTICE

If the housing is incorrectly assembled to the brush holder cover, the brush holder cover can pinch the rotor shaft which can result in an unsatisfactory seal.



6. Make sure that the holder cover groove and the brush holder tab are aligned (Figure 11-24, (1)).

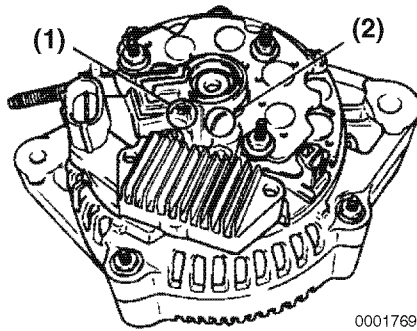

**Figure 11-24**

7. Make sure that the inner part of the holder cover is not pinched (Figure 11-24, (2)).

Note: Figure 11-25 shows a brush holder cover installed incorrectly. The brush holder tab is detached from the holder cover groove (Figure 11-25, (1)) and the inner part of the holder cover is pinched (Figure 11-25, (2)).

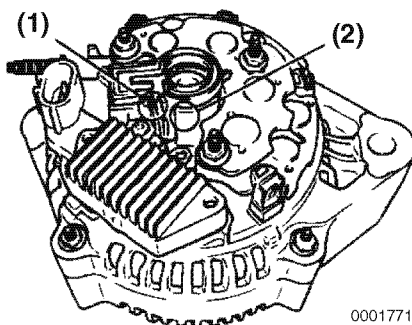

**Figure 11-25**

8. Make sure that the two brushes contact the slip rings on the rotor shaft.
9. Press as shown (Figure 11-26, (2)) and secure with the two bolts (Figure 11-26, (1)).

Tightening Torque			
	Target Value	Minimum Value	Maximum Value
SI Unit Display	1.96 N•m	1.57 N•m	2.35 N•m
Conventional Unit Display	19.9 kgf•cm	16.0 kgf•cm	23.9 kgf•cm

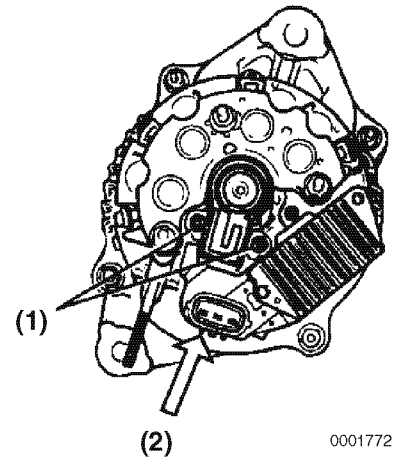

**Figure 11-26**

# ALTERNATOR

## Assembly of Alternator

1. If removed, install the thrust washer (Figure 11-27, (2)) in the rear frame housing. Lubricate the outside diameter of a new bearing (Figure 11-27, (1)). Press the bearing into the rear frame housing.

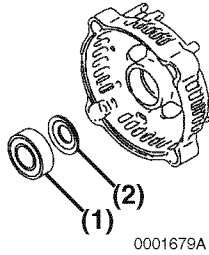

Figure 11-27

2. If removed, lubricate the outside diameter of a new front frame housing bearing. Press the bearing (Figure 11-28, (2)) into the front frame housing. Install the plate (Figure 11-28, (4)) to the front housing. Tighten the four bolts (Figure 11-28, (3)).

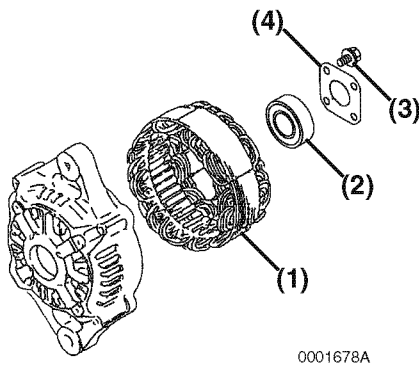

Figure 11-28

3. Position the stator assembly (Figure 11-28, (1)) on the front frame housing studs.
4. Lubricate the shaft of the rotor assembly (Figure 11-29, (1)). Press the rotor assembly into the front frame housing (Figure 11-29, (2)) and rear frame housing (Figure 11-29, (3)).

### NOTICE

Be careful not to drop the rotor. Damage to the slip rings or fan can result.

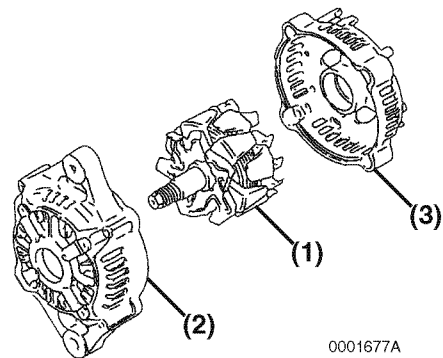

Figure 11-29

5. Align the front frame housing with the rear frame housing. Install the four bolts (Figure 11-30, (1)) and four nuts (Figure 11-30, (2)).

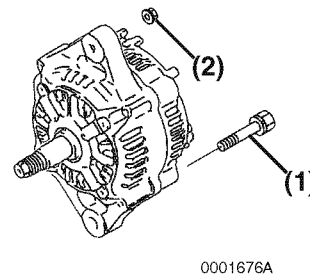

Figure 11-30

6. Install the insulation bushing (Figure 11-31, (4)) and nuts (Figure 11-31, (3)).

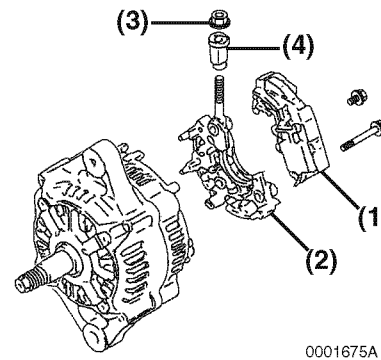
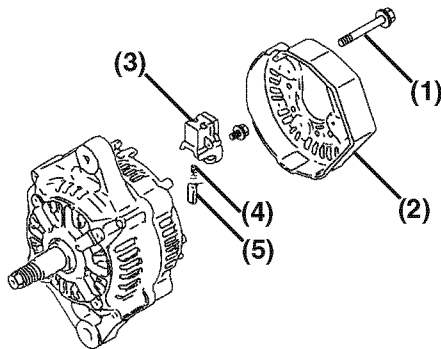

Figure 11-31

7. Install the rear cover (Figure 11-32, (2)) to the rear frame housing with three bolts (Figure 11-32, (1)).



0001674A

**Figure 11-32**

8. Assemble the pulley (Figure 11-33, (2)) and nut (Figure 11-33, (1)) to the shaft of the rotor assembly. Tighten the nut.

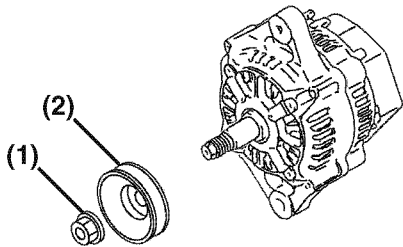

0001673A

**Figure 11-33**

## Installation of Alternator

1. Position the alternator on the gearcase. Loosely install the nut (Figure 11-34, (2)) on the gearcase stud and the V-belt adjuster bolt (Figure 11-34, (1)).

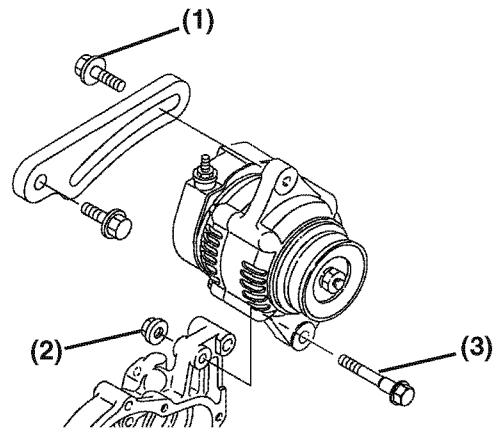

0001672A

**Figure 11-34**

2. Connect the electrical wires to the alternator. Tighten the nuts to 15 - 20 in lbs (1.7-2.3 N•m, 17-23 kgf•cm)
3. Install the V-belt. Tighten the V-belt to the proper tension. *See Check and Adjust Cooling Fan V-belt on page 5-9.*
4. Start the engine. Listen for any unusual sounds from the alternator.

### NOTICE

Do not use a high pressure wash directly on the alternator. Water will damage the alternator and result in inadequate charging.

5. Verify that the charge indicator is ON while the engine is operating. If the charge indicator is not ON, repair the problem before operating the engine.

# ALTERNATOR

## Bench Test

1. Check that the test bench is set up and that the charge light is ON.
2. Position the alternator (**Figure 11-35, (1)**) in the test bench.
3. Insert the main wiring harness (**Figure 11-35, (6)**) inspection connector into the alternator (**Figure 11-35, (1)**).
4. Connect the main wiring harness (**Figure 11-35, (6)**) and sub-wiring harness C (**Figure 11-35, (7)**).
5. Connect the voltmeter (**Figure 11-35, (2) and (3)**) and the ammeter (**Figure 11-35, (5)**) as shown.
6. Turn SW1 ON and check that the main wiring harness light (the charge light) (**Figure 11-35, (8)**) turns ON.

Note: If terminal S is disconnected during inspection, the charge light (**Figure 11-35, (8)**) may remain ON continuously. In this case, use sub-wiring harness B instead of sub-wiring harness C. Connect terminal S of sub-wiring harness B to terminal S on the alternator, turn SW1 ON, connect IG and L and check again.

7. Turn the test bench motor ON, increase speed and check that the charge light turns OFF (**Figure 11-35, (8)**).

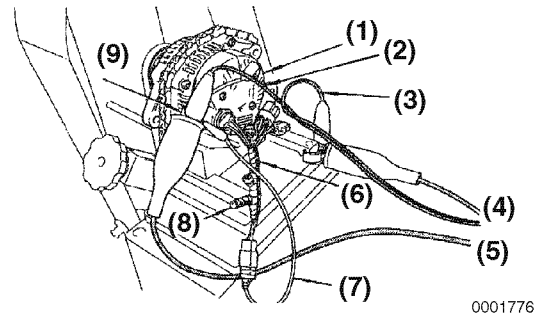
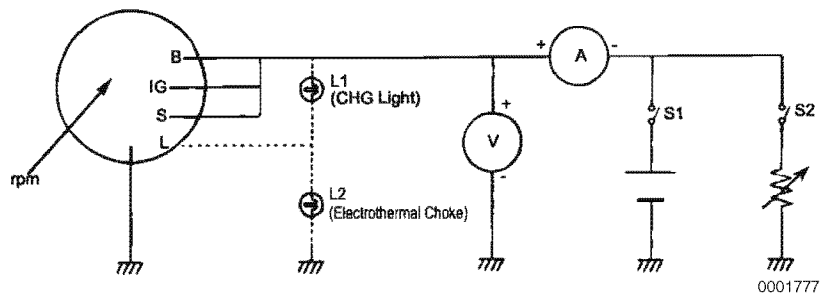

**Figure 11-35**

Item	Description
1	Alternator
2	Voltmeter Positive Side (+)
3	Voltmeter Negative Side (-)
4	To Battery Negative (-) Terminal
5	To Ammeter Positive (+) Terminal
6	Main Wiring Harness
7	Sub-wiring Harness C
8	Light
9	Terminal B

## Test Wiring

### Wiring Diagram for Alternators with an M Type Regulator.



### Wiring Diagram for Alternators with a GS Type Regulator.

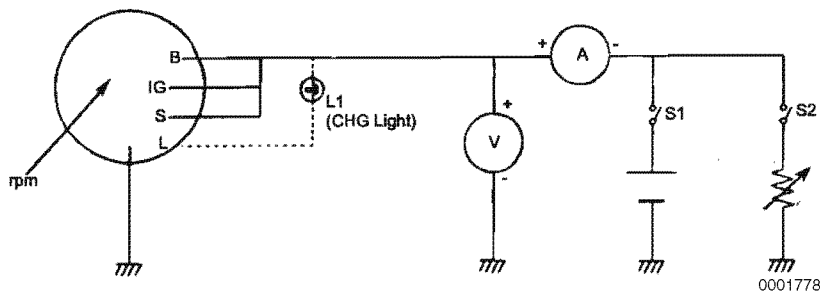

### Wiring Diagram for Alternators with a D or GA Type Regulator.

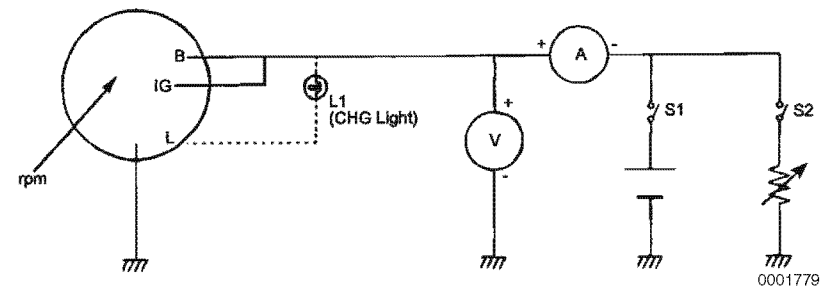

### Wiring Diagram for Alternators with a GL Type Regulator.

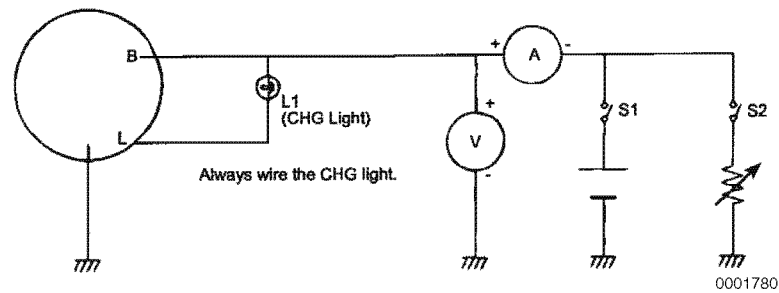

# ALTERNATOR

## Regulated Voltage Check

1. Turn battery switch S1 ON.
2. Run the alternator. Turn the load switch S2 ON when output current exceeds 0 (A).
3. Adjust the speed and the load to the standard values.
4. Check that the voltage is within the standard values.

Note: Regulated voltage has the temperature characteristics shown in **(Figure 11-36)**. Perform the measurement quickly.

3. While adjusting the speed and load resistance, set the speed and the voltage to the standard values.
4. Check that the current is within the standard values.

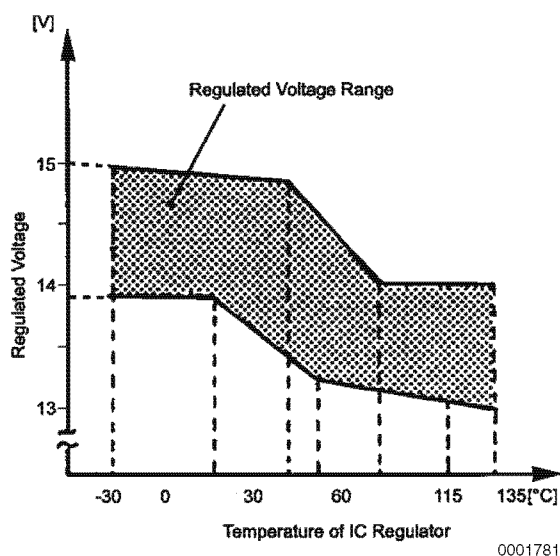

**Figure 11-36**

## No Load Test

1. Turn battery switch S1 ON.
2. Run the alternator. Turn S1 OFF when output current exceeds 0 (A).
3. Adjust the speed and the voltage to the standard values.
4. Check that the speed is within the standard values.

## Output Test

1. Turn battery switch S1 ON and load switch S2 ON.
2. Run the alternator.

## Section 12

# **ELECTRIC WIRING**

---

### Table of Contents

	<b>Page</b>
Electric Wiring Precautions .....	12-3
Electrical Wire Resistance.....	12-4
Battery Cable Resistance.....	12-5
Electrical Wire Sizes - Voltage Drop .....	12-6
Conversion of AWG to European Standards.....	12-7
Electric Wiring Diagram (Reference).....	12-8

**This Page Intentionally Left Blank**



## ELECTRIC WIRING PRECAUTIONS

Failure to follow these precautions may result in the failure of an electrical component and the loss of warranty coverage on that item as well as related items. Make sure that all users read and understand these precautions.

### NOTICE

- Do not reverse the positive and negative ends of the battery cable. The alternator diode and stator coil will be damaged.
- When the battery indicator goes out, it should not come on again. The battery indicator only comes on during operation if the alternator fails or if the V-belt breaks. However, if an LED is used in the battery indicator, the LED will shine faintly during normal operation.
- Make sure that the combined total resistance of the battery cable in both directions between the starter motor and the battery is within the value indicated in the Battery Cable Resistance chart in the Electric Wiring Section of this manual. The starter motor will malfunction and fail if the resistance is higher than the specified value.
- Removing the battery cables or battery while the engine is operating may cause damage to the current limiter depending on the electrical equipment being used. This situation could cause loss of control of output voltage. The continuous high voltage of 23-24 volts (for 5000 rpm dynamo) will damage the current limiter and other electrical equipment.
- Reversing the battery cable connections at the battery or on the engine will destroy the SCR diode in the current limiter. This will cause the charging system to malfunction and may cause damage to the electrical harnesses.

### ELECTRICAL WIRE RESISTANCE

AWG	Metric Nominal mm <sup>2</sup>	Ohms / Foot Resistance
20	0.5	0.009967
18	0.8	0.006340
16	1.25	0.004359
14	2	0.002685
12	3	0.001704
10	5	0.001073
8	8	0.000707
6	15	0.000421
4	20	0.000270
2	30	0.000158
1	40	0.000130
0 (1/0)	50	0.000103
00 (2/0)	60	0.000087
000 (3/0)	85	0.000066
0000 (4/0)	100	0.000051

Wiring voltage drop should not exceed 5%  $[0.05] \times 12 \text{ Volts} = 0.6 \text{ Volts}$ .

Voltage Drop = Current [Amps] x Length of Wire [Feet] x Resistance per Foot [Ohms]

Example:

Current draw of 100 Amps x 3 feet of 4 AWG wire

$100 \text{ Amps} \times 3 \text{ Feet} \times 0.000270 = 0.08 \text{ Volts [Voltage Drop]}$

## BATTERY CABLE RESISTANCE

AWG	mm <sup>2</sup>	Maximum Total Battery Cable Length (Positive Cable + Negative Cable + a*) 12V Starter Motor Output			
		Less Than 2.68 HP (2 kW)		Greater Than 2.68 HP (2 kW)	
		m	ft.	m	ft.
6	15	1.5	4.75	N/A	N/A
4	20	2.3	7.4	N/A	N/A
2	30	3.8	12.6	2.3	7.5
1	40	4.6	15.3	2.8	9.2
0 (1/0)	50	5.9	19.5	3.5	11.6
00 (2/0)	60	7.0	22.8	4.2	13.7
000(3/0)	85	9.3	30.5	5.6	18.3
0000 (4/0)	100	11.9	39.0	7.1	23.4
00000 (5/0)	125	N/A	N/A	8.3	27.3
000000 (6/0)	150	N/A	N/A	10.1	33.3

Note: Total allowable resistance of the complete battery cable circuit (positive cable + negative cable + a\*)  
(a\*: Resistance ( $\Omega$ ) of a battery switch or other electrical equipment having high resistance)

For starter motors of less than 2.68 HP (2 kW): the total resistance must be less than 0.002  $\Omega$

For starter motors of greater than 2.68 HP (2 kW): the total resistance must be less than 0.0012  $\Omega$

# ELECTRIC WIRING

## ELECTRICAL WIRE SIZES - VOLTAGE DROP

Total current on circuit in amps.	Length of conductor from source of current to device and back to source—feet																		
	10	15	20	25	30	40	50	60	70	80	90	100	110	120	130	140	150	160	170
<b>12 Volts</b>	Wire Size (AWG)																		
5	18	16	14	12	12	10	10	10	8	8	8	6	6	6	6	6	6	6	6
10	14	12	10	10	10	8	6	6	6	6	4	4	4	4	2	2	2	2	2
15	12	10	10	8	8	6	6	6	4	4	2	2	2	2	2	1	1	1	1
20	10	10	8	6	6	6	4	4	2	2	2	2	1	1	1	0	0	0	2/0
25	10	8	6	6	6	4	4	2	2	2	1	1	0	0	0	2/0	2/0	2/0	3/0
30	10	8	6	6	4	4	2	2	1	1	0	0	0	2/0	2/0	3/0	3/0	3/0	3/0
40	8	6	6	4	4	2	2	1	0	0	2/0	2/0	3/0	3/0	3/0	4/0	4/0	4/0	4/0
50	6	6	4	4	2	2	1	0	2/0	2/0	3/0	3/0	4/0	4/0	4/0				
60	6	4	4	2	2	1	0	2/0	3/0	3/0	4/0	4/0	4/0						
70	6	4	2	2	1	0	2/0	3/0	3/0	4/0	4/0								
80	6	4	2	2	1	0	3/0	3/0	4/0	4/0									
90	4	2	2	1	0	2/0	3/0	4/0	4/0										
100	4	2	2	1	0	2/0	3/0	4/0											
<b>24 Volts</b>																			
5	18	18	18	16	16	14	12	12	12	10	10	10	10	10	8	8	8	8	8
10	18	16	14	12	12	10	10	10	8	8	8	6	6	6	6	6	6	6	6
15	16	14	12	12	10	10	8	8	6	6	6	6	6	4	4	4	4	4	2
20	14	12	10	10	10	8	6	6	6	6	4	4	4	4	2	2	2	2	2
25	12	12	10	10	8	6	6	6	4	4	4	4	2	2	2	2	2	2	1
30	12	10	10	8	8	6	6	4	4	4	2	2	2	2	2	1	1	1	1
40	10	10	8	6	6	6	4	4	2	2	2	2	1	1	1	0	0	0	2/0
50	10	8	6	6	6	4	4	2	2	2	1	1	0	0	0	2/0	2/0	2/0	3/0
60	10	8	6	6	4	4	2	2	1	1	0	0	0	2/0	2/0	3/0	3/0	3/0	3/0
70	8	6	6	4	4	2	2	1	1	0	0	2/0	2/0	3/0	3/0	3/0	3/0	4/0	4/0
80	8	6	6	4	4	2	2	1	0	0	2/0	2/0	3/0	3/0	3/0	4/0	4/0	4/0	4/0
90	8	6	4	4	2	2	1	0	0	2/0	2/0	3/0	3/0	4/0	4/0	4/0	4/0	4/0	
100	6	6	4	4	2	2	1	0	2/0	2/0	3/0	3/0	4/0	4/0	4/0				

## CONVERSION OF AWG TO EUROPEAN STANDARDS

Conductor Size (AWG)	Conductor Diameter (mm)	Conductor Cross-sectional Area (mm <sup>2</sup> )
25	0.455	0.163
24	0.511	0.205
23	0.573	0.259
22	0.644	0.325
21	0.723	0.412
20	0.812	0.519
19	0.992	0.653
18	1.024	0.823
17	1.15	1.04
16	1.29	1.31
15	1.45	1.65
14	1.63	2.08
13	1.83	2.63
12	2.05	3.31
11	2.30	4.15
10	2.59	5.27
9	2.91	6.62
8	3.26	8.35
7	3.67	10.6
6	4.11	13.3
5	4.62	16.8
4	5.19	21.2
3	5.83	26.7
2	6.54	33.6
1	7.35	42.4
0 (1/0)	8.25	53.4
00 (2/0)	9.27	67.5
000(3/0)	10.40	85.0
0000 (4/0)	11.68	107.2
00000 (5/0)	13.12	135.1
000000 (6/0)	14.73	170.3

1.1 circular mil (CM)  $\cong$  0.0005067 mm<sup>2</sup>



## Section 13

# **TROUBLESHOOTING**

## Table of Contents

	<b>Page</b>
Special Service Tools.....	13-3
Troubleshooting By Measuring Compression Pressure .....	13-4
Quick Reference Table For Troubleshooting .....	13-6

**This Page Intentionally Left Blank**

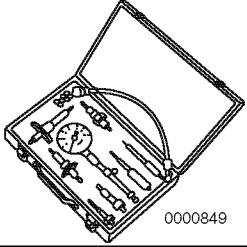

**SPECIAL SERVICE TOOLS**

Compression Gauge Kit	For measuring compression pressure Gauge Set Code No. TOL-97190080	 0000849
-----------------------	---	--

## TROUBLESHOOTING

### TROUBLESHOOTING BY MEASURING COMPRESSION PRESSURE

Compression pressure drop is one of major causes of increasing blow-by gas (engine oil contamination or increased engine oil consumption as a resultant phenomenon) or starting failure. The compression pressure is affected by the following factors:

1. Degree of clearance between piston and cylinder
2. Degree of clearance at intake / exhaust valve seat
3. Gas leak from nozzle gasket or cylinder head gasket

The pressure will drop due to increased parts wear. Pressure drop reduces the durability of the engine.

A pressure drop may also be caused by scratched cylinder or piston by dust entrance from the dirty air cleaner element or worn or broken piston ring. Measure the compression pressure to determine the condition of the engine.

#### Compression Pressure Measurement Method

1. Warm up the engine.
2. Stop the engine. Remove the high-pressure fuel injection lines as an assembly from the engine. Remove the fuel injector from the cylinder to be measured. *See Removal of the Fuel Injectors on page 7-35.*

#### NOTICE

Remove the high-pressure fuel injection lines as an assembly whenever possible. Disassembling the high-pressure fuel injection lines from the retainers or bending any of the fuel lines will make it difficult to reinstall the fuel lines.

3. Crank the engine with the stop handle at the stop position (no injection state) before installing the compression gauge (**Figure 13-1, (1)**) adapter.

4. Install a gasket at the tip end of the compression gauge adapter. Install the compression gauge and the compression gauge adapter at the cylinder to be measured.
5. Crank the engine until the compression gauge reading is stabilized.

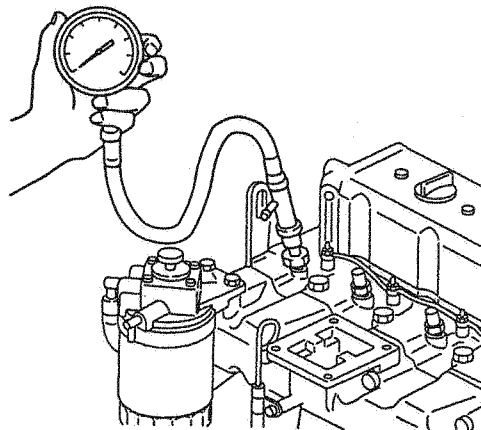

0001621

**Figure 13-1**

6. After performing the compression check, remove the compression gauge and compression gauge adapter from the cylinder. Install the fuel injector and high-pressure fuel injection lines. *See Installation of Fuel Injectors on page 7-39.*

### Standard Compression Pressure

Engine compression pressure list (reference value)

Engine Model	Compression Pressure at 250 rpm (250 min <sup>-1</sup> )		Deviation Between Cylinders
	Standard	Limit	
4TNE92 4TNE94L 4TNE98	426 ± 15 psi (2.94 ± 0.1 MPa, 30 ± 1 kgf/cm <sup>2</sup> )	341 ± 15 psi (2.35 ± 0.1 MPa, 24 ± 1 kgf/cm <sup>2</sup> )	29 to 43 psi (0.2 to 0.3 MPa, 2 to 3 kgf/cm <sup>2</sup> )

### Engine Speed and Compression Pressure (Use for Reference)

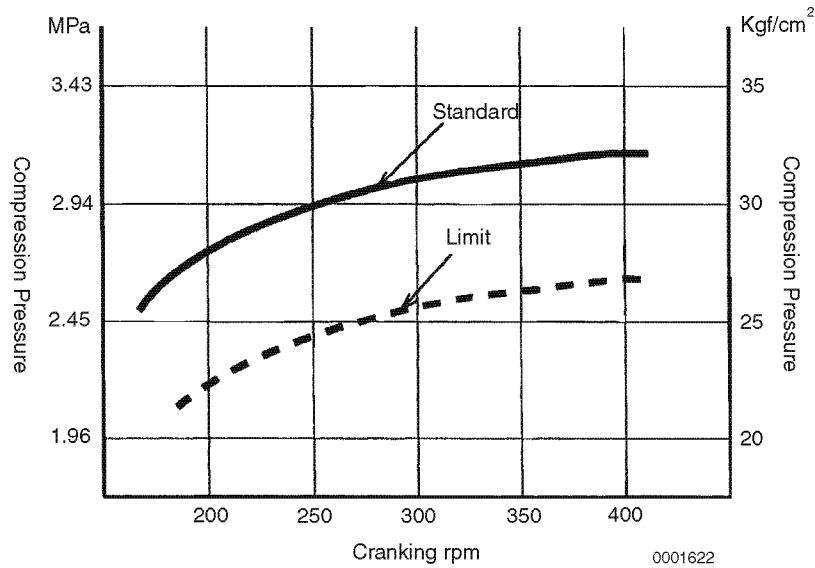

Figure 13-2

# TROUBLESHOOTING

## Measured Value and Troubleshooting

When the measured compression pressure is below the limit value, inspect each part by referring to the table below.

No.	Item	Cause	Corrective Action
1	Air Cleaner Element	Clogged element	Clean the element.
		Broken element	Replace the element.
		Defect at element seal portion	
2	Valve Clearance	Excessive or no clearance	Adjust the valve clearance.
3	Valve Timing	Incorrect valve clearance	Adjust the valve clearance.
4	Cylinder Head Gasket	Gas leak from gasket	Replace the gasket.
			Retighten the cylinder head bolts to the specified torque.
5	Intake/Exhaust Valve	Sticking valve	Replace the intake/exhaust valve.
	Valve Seat	Gas leak due to worn valve seat or foreign matter trapped in valve	Lap the valve seat.
6	Piston	Gas leak due to scratching or wear	Perform honing and use an oversized part.
	Piston Ring		
	Cylinder		

## QUICK REFERENCE TABLE FOR TROUBLESHOOTING

The following table summarizes the general trouble symptoms and their causes. If any trouble symptom occurs, take corrective action before it becomes a serious problem so as not to shorten the engine service life.

Cause	Trouble Symptom	Starting Problem			Insufficient Engine Output		Poor Exhaust Color		High Knocking Sound During Combustion	Abnormal Engine Sound	Uneven Combustion Sound	Engine Surging		Difficulty in Returning to Low Speed	Engine Oil					Engine Coolant		Air Intake		Corrective Action							
		Engine Does Not Start.	Engine Starts But Stops Soon.		Exhaust Color	During Work	During Idling	During Work Operation				Excessive Engine Vibration	Excessive Fuel Consumption		Excessive Oil Consumption	Dilution by Diesel Fuel	Oil with Water	Low Oil Pressure	Excessive Blow-by Gas	Overheat	Low Water Temperature	Pressure Drop	Pressure Rise		Exhaust Temperature Rise						
			None	Little																						Much	Ordinary	White	Black	White	Black
Engine System	Improper Intake/Exhaust Valve Clearance	<input type="checkbox"/>	<input type="checkbox"/>	<input type="checkbox"/>	<input type="checkbox"/>	<input type="checkbox"/>	<input type="checkbox"/>	<input type="checkbox"/>	<input type="checkbox"/>	<input type="checkbox"/>	<input type="checkbox"/>	<input type="checkbox"/>	<input type="checkbox"/>	<input type="checkbox"/>	<input type="checkbox"/>	<input type="checkbox"/>	<input type="checkbox"/>	<input type="checkbox"/>	<input type="checkbox"/>	<input type="checkbox"/>	<input type="checkbox"/>	<input type="checkbox"/>	<input type="checkbox"/>	Adjust the Valve Clearance.							
	Compression Leakage from Valve Seat	<input type="checkbox"/>	<input type="checkbox"/>	<input type="checkbox"/>	<input type="checkbox"/>	<input type="checkbox"/>	<input type="checkbox"/>	<input type="checkbox"/>	<input type="checkbox"/>	<input type="checkbox"/>	<input type="checkbox"/>	<input type="checkbox"/>	<input type="checkbox"/>	<input type="checkbox"/>	<input type="checkbox"/>	<input type="checkbox"/>	<input type="checkbox"/>	<input type="checkbox"/>	<input type="checkbox"/>	<input type="checkbox"/>	<input type="checkbox"/>	<input type="checkbox"/>	<input type="checkbox"/>	Lap the Valve Seat.							
	Intake/Exhaust Valve Seizure	<input type="checkbox"/>	<input type="checkbox"/>	<input type="checkbox"/>	<input type="checkbox"/>	<input type="checkbox"/>	<input type="checkbox"/>	<input type="checkbox"/>	<input type="checkbox"/>	<input type="checkbox"/>	<input type="checkbox"/>	<input type="checkbox"/>	<input type="checkbox"/>	<input type="checkbox"/>	<input type="checkbox"/>	<input type="checkbox"/>	<input type="checkbox"/>	<input type="checkbox"/>	<input type="checkbox"/>	<input type="checkbox"/>	<input type="checkbox"/>	<input type="checkbox"/>	<input type="checkbox"/>	<input type="checkbox"/>	Correct or Replace Intake/Exhaust Valve.						
	Cylinder Head Gasket Blowout	<input type="checkbox"/>	<input type="checkbox"/>	<input type="checkbox"/>	<input type="checkbox"/>	<input type="checkbox"/>	<input type="checkbox"/>	<input type="checkbox"/>	<input type="checkbox"/>	<input type="checkbox"/>	<input type="checkbox"/>	<input type="checkbox"/>	<input type="checkbox"/>	<input type="checkbox"/>	<input type="checkbox"/>	<input type="checkbox"/>	<input type="checkbox"/>	<input type="checkbox"/>	<input type="checkbox"/>	<input type="checkbox"/>	<input type="checkbox"/>	<input type="checkbox"/>	<input type="checkbox"/>	<input type="checkbox"/>	Replace the Gasket.						
	Seized or Broken Piston Ring	<input type="checkbox"/>	<input type="checkbox"/>	<input type="checkbox"/>	<input type="checkbox"/>	<input type="checkbox"/>	<input type="checkbox"/>	<input type="checkbox"/>	<input type="checkbox"/>	<input type="checkbox"/>	<input type="checkbox"/>	<input type="checkbox"/>	<input type="checkbox"/>	<input type="checkbox"/>	<input type="checkbox"/>	<input type="checkbox"/>	<input type="checkbox"/>	<input type="checkbox"/>	<input type="checkbox"/>	<input type="checkbox"/>	<input type="checkbox"/>	<input type="checkbox"/>	<input type="checkbox"/>	<input type="checkbox"/>	Replace the Piston Ring.						
	Worn Piston Ring, Piston or Cylinder	<input type="checkbox"/>	<input type="checkbox"/>	<input type="checkbox"/>	<input type="checkbox"/>	<input type="checkbox"/>	<input type="checkbox"/>	<input type="checkbox"/>	<input type="checkbox"/>	<input type="checkbox"/>	<input type="checkbox"/>	<input type="checkbox"/>	<input type="checkbox"/>	<input type="checkbox"/>	<input type="checkbox"/>	<input type="checkbox"/>	<input type="checkbox"/>	<input type="checkbox"/>	<input type="checkbox"/>	<input type="checkbox"/>	<input type="checkbox"/>	<input type="checkbox"/>	<input type="checkbox"/>	<input type="checkbox"/>	Perform Honing and Use Oversize Parts.						
	Seized Crankpin Metal or Bearing	<input type="checkbox"/>	<input type="checkbox"/>	<input type="checkbox"/>	<input type="checkbox"/>	<input type="checkbox"/>	<input type="checkbox"/>	<input type="checkbox"/>	<input type="checkbox"/>	<input type="checkbox"/>	<input type="checkbox"/>	<input type="checkbox"/>	<input type="checkbox"/>	<input type="checkbox"/>	<input type="checkbox"/>	<input type="checkbox"/>	<input type="checkbox"/>	<input type="checkbox"/>	<input type="checkbox"/>	<input type="checkbox"/>	<input type="checkbox"/>	<input type="checkbox"/>	<input type="checkbox"/>	<input type="checkbox"/>	Repair or Replace.						
	Improper Arrangement of Piston Ring Joints	<input type="checkbox"/>	<input type="checkbox"/>	<input type="checkbox"/>	<input type="checkbox"/>	<input type="checkbox"/>	<input type="checkbox"/>	<input type="checkbox"/>	<input type="checkbox"/>	<input type="checkbox"/>	<input type="checkbox"/>	<input type="checkbox"/>	<input type="checkbox"/>	<input type="checkbox"/>	<input type="checkbox"/>	<input type="checkbox"/>	<input type="checkbox"/>	<input type="checkbox"/>	<input type="checkbox"/>	<input type="checkbox"/>	<input type="checkbox"/>	<input type="checkbox"/>	<input type="checkbox"/>	<input type="checkbox"/>	Correct the Ring Joint Positions.						
	Reverse Assembly of Piston Rings	<input type="checkbox"/>	<input type="checkbox"/>	<input type="checkbox"/>	<input type="checkbox"/>	<input type="checkbox"/>	<input type="checkbox"/>	<input type="checkbox"/>	<input type="checkbox"/>	<input type="checkbox"/>	<input type="checkbox"/>	<input type="checkbox"/>	<input type="checkbox"/>	<input type="checkbox"/>	<input type="checkbox"/>	<input type="checkbox"/>	<input type="checkbox"/>	<input type="checkbox"/>	<input type="checkbox"/>	<input type="checkbox"/>	<input type="checkbox"/>	<input type="checkbox"/>	<input type="checkbox"/>	<input type="checkbox"/>	Reassemble Correctly.						
	Worn Crankpin and Journal Bearing	<input type="checkbox"/>	<input type="checkbox"/>	<input type="checkbox"/>	<input type="checkbox"/>	<input type="checkbox"/>	<input type="checkbox"/>	<input type="checkbox"/>	<input type="checkbox"/>	<input type="checkbox"/>	<input type="checkbox"/>	<input type="checkbox"/>	<input type="checkbox"/>	<input type="checkbox"/>	<input type="checkbox"/>	<input type="checkbox"/>	<input type="checkbox"/>	<input type="checkbox"/>	<input type="checkbox"/>	<input type="checkbox"/>	<input type="checkbox"/>	<input type="checkbox"/>	<input type="checkbox"/>	<input type="checkbox"/>	Measure and Replace.						
	Loose Connecting Rod Bolt	<input type="checkbox"/>	<input type="checkbox"/>	<input type="checkbox"/>	<input type="checkbox"/>	<input type="checkbox"/>	<input type="checkbox"/>	<input type="checkbox"/>	<input type="checkbox"/>	<input type="checkbox"/>	<input type="checkbox"/>	<input type="checkbox"/>	<input type="checkbox"/>	<input type="checkbox"/>	<input type="checkbox"/>	<input type="checkbox"/>	<input type="checkbox"/>	<input type="checkbox"/>	<input type="checkbox"/>	<input type="checkbox"/>	<input type="checkbox"/>	<input type="checkbox"/>	<input type="checkbox"/>	<input type="checkbox"/>	Tighten to the Specified Torque.						
	Foreign Matter Trapped in Combustion Chamber	<input type="checkbox"/>	<input type="checkbox"/>	<input type="checkbox"/>	<input type="checkbox"/>	<input type="checkbox"/>	<input type="checkbox"/>	<input type="checkbox"/>	<input type="checkbox"/>	<input type="checkbox"/>	<input type="checkbox"/>	<input type="checkbox"/>	<input type="checkbox"/>	<input type="checkbox"/>	<input type="checkbox"/>	<input type="checkbox"/>	<input type="checkbox"/>	<input type="checkbox"/>	<input type="checkbox"/>	<input type="checkbox"/>	<input type="checkbox"/>	<input type="checkbox"/>	<input type="checkbox"/>	<input type="checkbox"/>	Disassemble and Repair.						
	Excessive Gear Backlash	<input type="checkbox"/>	<input type="checkbox"/>	<input type="checkbox"/>	<input type="checkbox"/>	<input type="checkbox"/>	<input type="checkbox"/>	<input type="checkbox"/>	<input type="checkbox"/>	<input type="checkbox"/>	<input type="checkbox"/>	<input type="checkbox"/>	<input type="checkbox"/>	<input type="checkbox"/>	<input type="checkbox"/>	<input type="checkbox"/>	<input type="checkbox"/>	<input type="checkbox"/>	<input type="checkbox"/>	<input type="checkbox"/>	<input type="checkbox"/>	<input type="checkbox"/>	<input type="checkbox"/>	<input type="checkbox"/>	Adjust Gear Meshing.						
	Worn Intake/Exhaust Valve Guide	<input type="checkbox"/>	<input type="checkbox"/>	<input type="checkbox"/>	<input type="checkbox"/>	<input type="checkbox"/>	<input type="checkbox"/>	<input type="checkbox"/>	<input type="checkbox"/>	<input type="checkbox"/>	<input type="checkbox"/>	<input type="checkbox"/>	<input type="checkbox"/>	<input type="checkbox"/>	<input type="checkbox"/>	<input type="checkbox"/>	<input type="checkbox"/>	<input type="checkbox"/>	<input type="checkbox"/>	<input type="checkbox"/>	<input type="checkbox"/>	<input type="checkbox"/>	<input type="checkbox"/>	<input type="checkbox"/>	Measure and Replace.						
Governor Adjusted Incorrectly	<input type="checkbox"/>	<input type="checkbox"/>	<input type="checkbox"/>	<input type="checkbox"/>	<input type="checkbox"/>	<input type="checkbox"/>	<input type="checkbox"/>	<input type="checkbox"/>	<input type="checkbox"/>	<input type="checkbox"/>	<input type="checkbox"/>	<input type="checkbox"/>	<input type="checkbox"/>	<input type="checkbox"/>	<input type="checkbox"/>	<input type="checkbox"/>	<input type="checkbox"/>	<input type="checkbox"/>	<input type="checkbox"/>	<input type="checkbox"/>	<input type="checkbox"/>	<input type="checkbox"/>	<input type="checkbox"/>	Make Adjustment.							
Improper Open/Close Timing of Intake/Exhaust Valves	<input type="checkbox"/>	<input type="checkbox"/>	<input type="checkbox"/>	<input type="checkbox"/>	<input type="checkbox"/>	<input type="checkbox"/>	<input type="checkbox"/>	<input type="checkbox"/>	<input type="checkbox"/>	<input type="checkbox"/>	<input type="checkbox"/>	<input type="checkbox"/>	<input type="checkbox"/>	<input type="checkbox"/>	<input type="checkbox"/>	<input type="checkbox"/>	<input type="checkbox"/>	<input type="checkbox"/>	<input type="checkbox"/>	<input type="checkbox"/>	<input type="checkbox"/>	<input type="checkbox"/>	<input type="checkbox"/>	Adjust the Valve Clearance.							
Turbocharger	Fouled Blower	<input type="checkbox"/>	<input type="checkbox"/>	<input type="checkbox"/>	<input type="checkbox"/>	<input type="checkbox"/>	<input type="checkbox"/>	<input type="checkbox"/>	<input type="checkbox"/>	<input type="checkbox"/>	<input type="checkbox"/>	<input type="checkbox"/>	<input type="checkbox"/>	<input type="checkbox"/>	<input type="checkbox"/>	<input type="checkbox"/>	<input type="checkbox"/>	<input type="checkbox"/>	<input type="checkbox"/>	<input type="checkbox"/>	<input type="checkbox"/>	<input type="checkbox"/>	<input type="checkbox"/>	<input type="checkbox"/>	Wash the Blower.						
	Waste Gate Malfunction	<input type="checkbox"/>	<input type="checkbox"/>	<input type="checkbox"/>	<input type="checkbox"/>	<input type="checkbox"/>	<input type="checkbox"/>	<input type="checkbox"/>	<input type="checkbox"/>	<input type="checkbox"/>	<input type="checkbox"/>	<input type="checkbox"/>	<input type="checkbox"/>	<input type="checkbox"/>	<input type="checkbox"/>	<input type="checkbox"/>	<input type="checkbox"/>	<input type="checkbox"/>	<input type="checkbox"/>	<input type="checkbox"/>	<input type="checkbox"/>	<input type="checkbox"/>	<input type="checkbox"/>	<input type="checkbox"/>	Disassemble and Inspect.						
	Worn Radial Bearing	<input type="checkbox"/>	<input type="checkbox"/>	<input type="checkbox"/>	<input type="checkbox"/>	<input type="checkbox"/>	<input type="checkbox"/>	<input type="checkbox"/>	<input type="checkbox"/>	<input type="checkbox"/>	<input type="checkbox"/>	<input type="checkbox"/>	<input type="checkbox"/>	<input type="checkbox"/>	<input type="checkbox"/>	<input type="checkbox"/>	<input type="checkbox"/>	<input type="checkbox"/>	<input type="checkbox"/>	<input type="checkbox"/>	<input type="checkbox"/>	<input type="checkbox"/>	<input type="checkbox"/>	<input type="checkbox"/>	Disassemble and Inspect.						



Cause	Trouble Symptom	Starting Problem			Insufficient Engine Output		Poor Exhaust Color		High Knocking Sound During Combustion	Abnormal Engine Sound	Uneven Combustion Sound	Engine Surging		Excessive Engine Vibration	Difficulty in Returning to Low Speed	Excessive Fuel Consumption	Engine Oil				Engine Coolant		Air Intake		Corrective Action		
		Engine Does Not Start.	Engine Starts but Stops Soon.		Exhaust Color		During Work					During Idling	During Work Operation				Excessive Oil Consumption	Dilution by Diesel Fuel	Oil with Water	Low Oil Pressure	Excessive Blow-by Gas	Overheat	Low Water Temperature	Pressure Drop		Pressure Rise	Exhaust Temperature Rise
			None	Little	Much	Ordinary	White	Black																			
Air/Exhaust Gas System	Clogged Air Filter			○			○	○		○										○			Clean Air Filter.				
	Engine Used at High Temperatures or at High Altitude						○	○							○				○		○			Study Output Drop and Load Matching.			
	Clogged Exhaust Pipe						○	○		○												○		Clean Exhaust Pipe.			
Electrical System	Starting Motor Defect	○																						Repair or Replace Stater Motor.			
	Alternator Defect	○																						Repair or Replace Alternator.			
	Open-Circuit in Wiring	○																						Repair Open Circuit.			
	Battery Voltage Drop	○																						Inspect and Change the Battery.			

**This Page Intentionally Left Blank**



# **YANMAR®**

## **Head Office: Yanmar Co., Ltd.**

1-32 Chayamachi, Kita-ku, Osaka Japan  
<http://www.yanmar.co.jp>

---

## **Yanmar America Corporation**

951 Corporate Grove Drive  
Buffalo Grove, IL 60089-4508, U.S.A.  
TEL: 1-847-541-1900 FAX: 1-847-541-2161  
<http://www.yanmar.com>

## **Yanmar Europe B.V.**

Brugplein11, 1332 BS Almere -de Vaart,  
The Netherlands.  
TEL: 31-36-5493200 FAX: 31-36-5493209  
<http://www.yanmar.nl>

## **Yanmar Asia (Singapore) Corporation Pte. Ltd.**

4 Tuas Lane, Singapore 638613  
TEL: 65-68615077 FAX: 65-68611509  
<http://www.yanmar.co.jp/yasc/>

## **Yanmar Engine (Shanghai) Corporation Ltd.**

No.6 work shop, EUREKA City Industrial Park, Lane 333  
Zhujian road, Minhang district, Shanghai, China  
TEL: 21-62210006 FAX: 21-62211699  
<http://www.yanmar-sha.com>

## **Yanmar South America Industria De Maquinas Ltda.**

Av. Presidente Vargas 1400, Indaiatuba, S.P., Brazil, CEP: 13338-901  
TEL: 19-3801-9224 FAX: 19-3875-3899, 2241  
<http://www.yanmar.com.br>

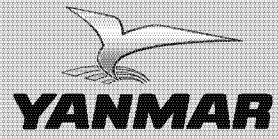

**YANMAR CO.,LTD.**