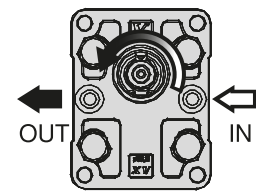
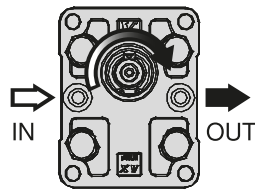

POMPES A ENGRENAGES - IDENTIFICATION

Expéditeur _____	<input type="checkbox"/> Commande	
Numéro de client _____	Date _____	<input type="checkbox"/> Demande d'offre

Marque de la pompe _____
 Cylindrée _____
 Numéro frappé _____
 Machine type _____

<input type="checkbox"/> Rotation à gauche 	<input type="checkbox"/> Rotation à droite 
--	---

Flasque

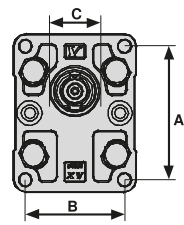
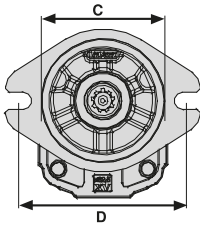
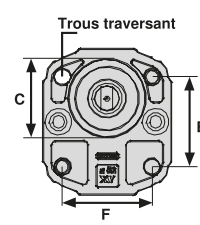
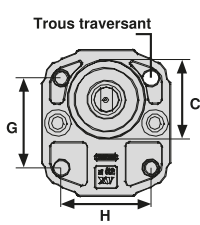
<input type="checkbox"/>  A _____ B _____ C _____	<input type="checkbox"/>  D _____ C _____	<input type="checkbox"/> Trous traversant  E _____ F _____ C _____	<input type="checkbox"/> Trous traversant  G _____ H _____ C _____
--	---	---	--

Entraînement débit

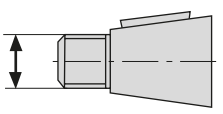
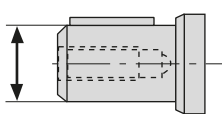
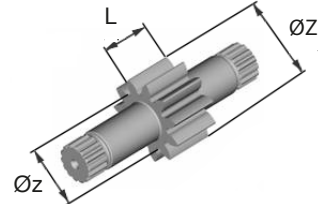
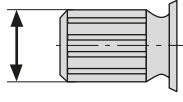
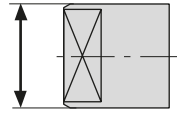
<input type="checkbox"/> Cône ____  Ø _____ Epaisseur de clavette _____	<input type="checkbox"/> Cylindrique  Ø _____ Epaisseur de clavette _____	 Øz _____ ØZ _____ L _____
<input type="checkbox"/> Entraînement cannelé  Ø _____ Nombres de dents _____	<input type="checkbox"/> Entraînement tournevis  Ø _____ Epaisseur tournevis _____	

Raccord aspiration / Raccord pression

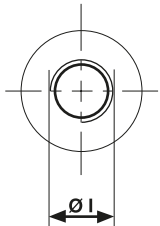
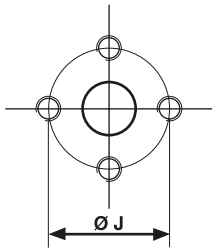
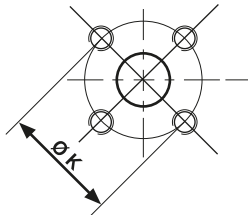
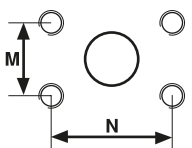
<input type="checkbox"/> Filetage intérieur Ø-Côté aspiration I _____ Ø-Côté pression I _____ 	<input type="checkbox"/> +-Orientation Ø-Côté aspiration J _____ Ø-Côté pression J _____ 	<input type="checkbox"/> X-Orientation Ø-Côté aspiration K _____ Ø-Côté pression K _____ 	<input type="checkbox"/> Flasque SAE Côté aspiration M _____ Côté aspiration N _____ Côté pression M _____ Côté pression N _____ 
--	---	--	---