

L-0 model

Sebango code: AZ	MH	PT
Assy / B1:		
TB / C1:		
Pack / F1:		
Prod.Eng:		
Date:		

Drawing No.	G2-14320-0060(1/3)
Date	Aug. 23 rd , 2006
Revision No.	
Revision Date	
Design model ID	714320G
Production model ID	114321A
Dev. Request No.	

Engine Specification

For L100N6CF1T1AA

(Standard for General : Recoil starting)

Contents		
Engine Specifications		G2-14320-0060(2/3)
Engine Performance		G2-14320-0060(2/3)
Details of specifications		G2-14320-0060(3/3)
Attached	Outline	B2-14320-0060
	Labels	G2-14220-2010
	Performance curve	Not Attached
	Tools	C2-14110-0010
	Wiring	Not Attached

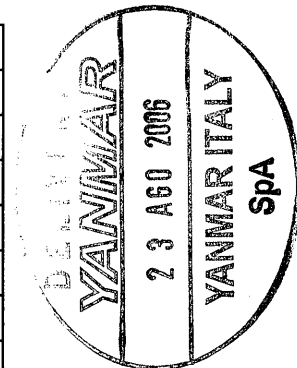

Revision	(Aug.23rd.2006)Registered by YITILU050102



YI Engineering Dept.		
Approved	Checked	Drawn
<i>J. Leone</i>	<i>A. Leone</i>	<i>J. Nishimura</i>

Revision No.

G2-14320-0060 (2/3)

1. Specification

Model name			L100N6CF1T1AA
Type			4-stroke, vertical-cyl, air-cooled diesel
Combustion system			Direct injection
No. of cyl.-bore×stroke		mm	1- ϕ 86 × 75
Displacement		liter	0.435
Output	Continuous	kW / min ⁻¹	* 6.6 (9.0PS ,8.9HP) / 3600
	Maximum	kW / min ⁻¹	* 7.4 (10.0PS ,9.9HP) / 3600
PTO Shaft	PTO position		Crankshaft
	Dir. of rotation		Counterclockwise viewed from PTO side
Injection timing (FID)		deg.	bTDC. 13.0±1.0
Fuel	Oil selection		Diesel fuel
	Tank capacity	liter	5.4
Lubricating	Oil selection		SAE 10W30, API grade CD or higher
	Oil capacity	liter	1.6 (effective, 0.6)
Cooling system			Forced air cooling by flywheel fan
Starting system			Re-coil starter
Governor			All speed type, mechanical
Balancer shaft			Single balancer shaft
Air cleaner			Dry type paper element filter
Exhaust silencer			Expansion silencer with cover
Generator			NA
Dimensions		mm	Indication in outline drawing
Dry weight		kg	Approx. 48.5

* Output is given for normal atmosphere conditions and Specs, which are defined as follows:

- Atmospheric pressure: 100 kPa (750mmHg)
- Atmospheric temperature: 25 °C
- Relative humidity: 30%

2. Engine performance

Speed at no load	Minimum	min ⁻¹	1200 or more	PTO Shaft (Without minimum idling speed adjust bolt. Adjustable figure by your end.)
	Maximum	min ⁻¹	3800±30	
Governor regulation	Instantaneous speed difference	%	8 or less	At Continuous Output point
	Permanent speed change	%	5 or less	
	Recovery time	sec.	5 or less	
	Speed fluctuation	min ⁻¹	30 or less	
Permissible angle of inclination	Continuous	deg.	20	Operation of up to 3 minutes
	Intermittent	deg.	30	
Lowest start temperature	Recoil starting	°C	0	Without starting aid agent

Revision No.			
--------------	--	--	--

G2-14320-0060 (3/3)

3. Details of specifications (STD.SPEC L100N6CA1T1AA)

System	Part name	Code	STD Spec.	Specification	Remarks
Fuel System	Fuel tank	Bm-a	1	same as STD.	
	Tank stay (A)		114210-55210	same as STD.	
	Tank stay (B)		114310-55230	same as STD.	
	Fuel injection Nozzle		714320-53100	same as STD.	
	F.O. Pump		714320-51100	same as STD.	N4A
Lubricating System	Oil pressure switch	Cm-a	NA	same as STD.	
Cooling System	Flywheel	Dm-a	114699-21590	same as STD.	DE type
	Fancase	Dm-b	114310-45100	same as STD.	Color: Gold Silver
	Engine Cover	Dm-c	1	same as STD.	
Electric System	Electric Regulator & Harness, wire	-	114399-77550	NA	
	Dynamo Assy.	-	114399-78260	NA	
	Air heater	Em-a	NA	same as STD.	
PTO & Flange	Crankshaft	Fm-a	1	same as STD.	E-D type
	Crankcase cover	-	114310-01450	same as STD.	E-D type
Intake and Exhaust System	Air cleaner	Gm-a	1	same as STD.	
	Intake bend	Gm-b	NA	same as STD.	
	Silencer	Gm-c	1	same as STD.	
Starting System	Recoil starter Assy	Hm-a	1	same as STD.	Recoil angle R5
	Starting motor	Hm-b	114362-77011	NA	With Cover
Speed Control System	Control device Assy	lm-a	1	same as STD.	General type
	Governor lever Assy	-	114311-61500	same as STD.	2 lever type
	Spring Regulator	-	114320-66010	same as STD.	Spring Position 1-B
	Fuel limiter Assy	-	114320-66600	same as STD.	Torque limiter type For 3600 rpm
Decomp System	Bonnet	Lm-a	1	same as STD.	
Remarks	Fuel oil limiter: locked by wire High idle adjust bolt: locked by wire Lubricating oil: not provided				
Loose Parts	Key switch panel CMP		114351-77500	NA	
	Connector		NA	same as STD.	
	Deflector		114699-13800	same as STD.	
	Tools		114299-92590	same as STD.	

NEED	PURCHASING SPECIFICATION	REQUEST FOR APPROVAL	DELIVERY DRAWING	INSPECTING STANDARD	QC-PROCESS
GEN. TO.	OUTSIDE 2/100 INSIDE 3/100	NOMINAL DIM. DIVISION	5 MAX = 10 = 18 = 30 = 50	5 TO = 10 = 18 = 30 = 50	30 TO = 50
DRAFT ANG.	CAST MALL THICK	SANDMOLD	±1.0 ±1.5 ±2.0 ±3.0 ±3.5	±1.0 ±1.5 ±2.0 ±3.0 ±4.0 ±5.0 ±7.0	L.-CAST
		SHELL	±0.8 ±1.0 ±1.5 ±2.0 ±2.0	±1.0 ±1.5 ±2.0 ±3.0 ±4.0 ±6.0	

L.-CHIP	ANG.-CHIP	10 MAX ±1DEG.
0.5 TO = 6 ±0.1	400 TO = 1000 ±0.8	10 TO = 50 ±30MIN
6 TO = 30 ±0.2	1000 TO = 2000 ±1.2	50 TO = 120 ±20MIN
30 TO = 120 ±0.3	2000 TO = 4000 ±2.0	120 TO = 400 ±10MIN
120 TO = 400 ±0.5		400 MIN ±5MIN

FIGURE DIMENSION	GT.CODE	○ AND √: RADIAL
------------------	---------	-----------------

CAREER

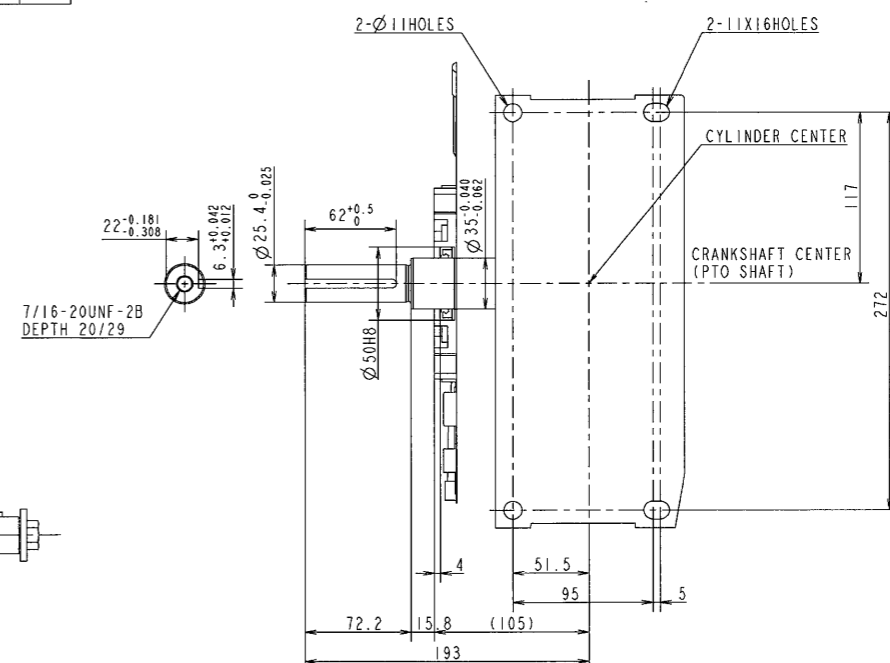
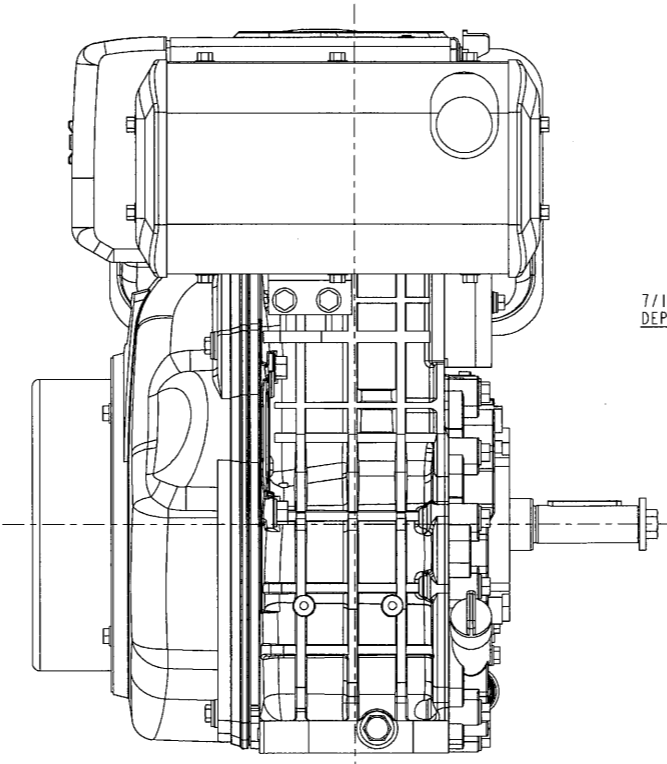
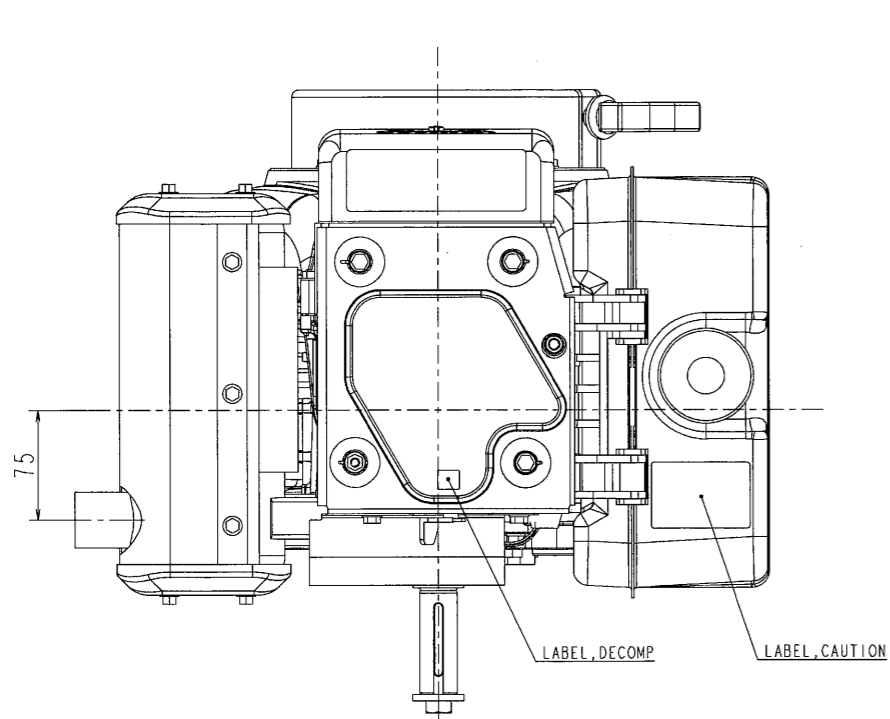

ENGINE MOUNTING PLATE AND PTO SHAFT SEEN THROUGH FROM THE TOP OF THIS ENGINE

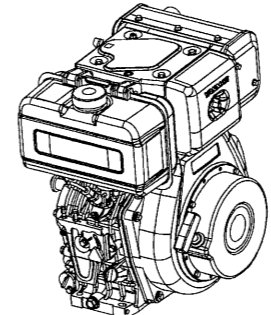
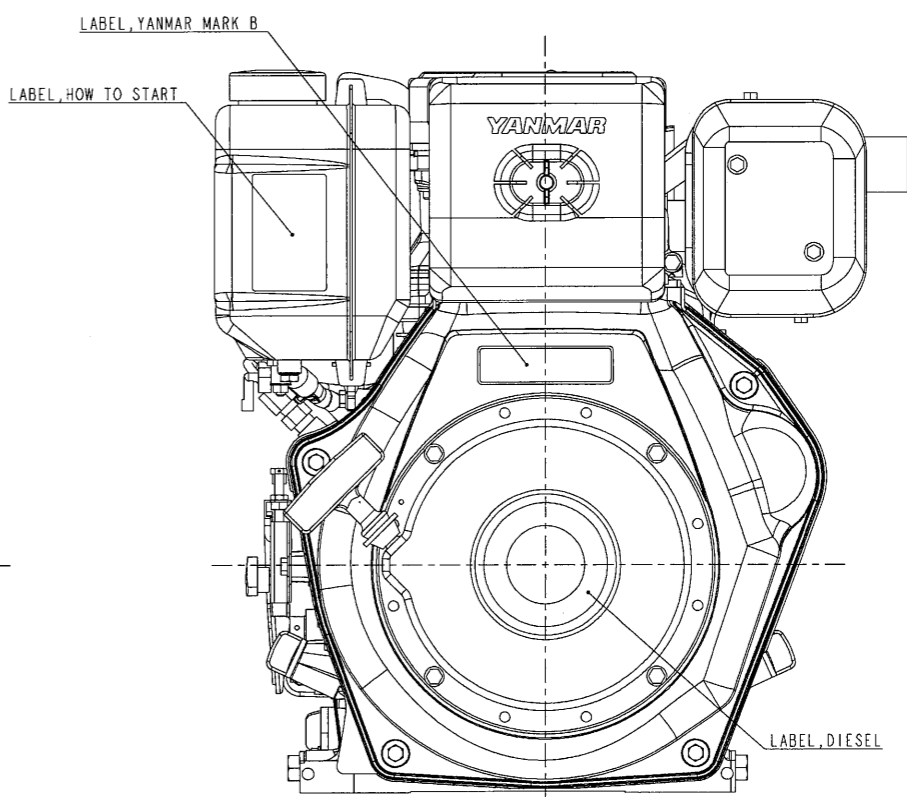
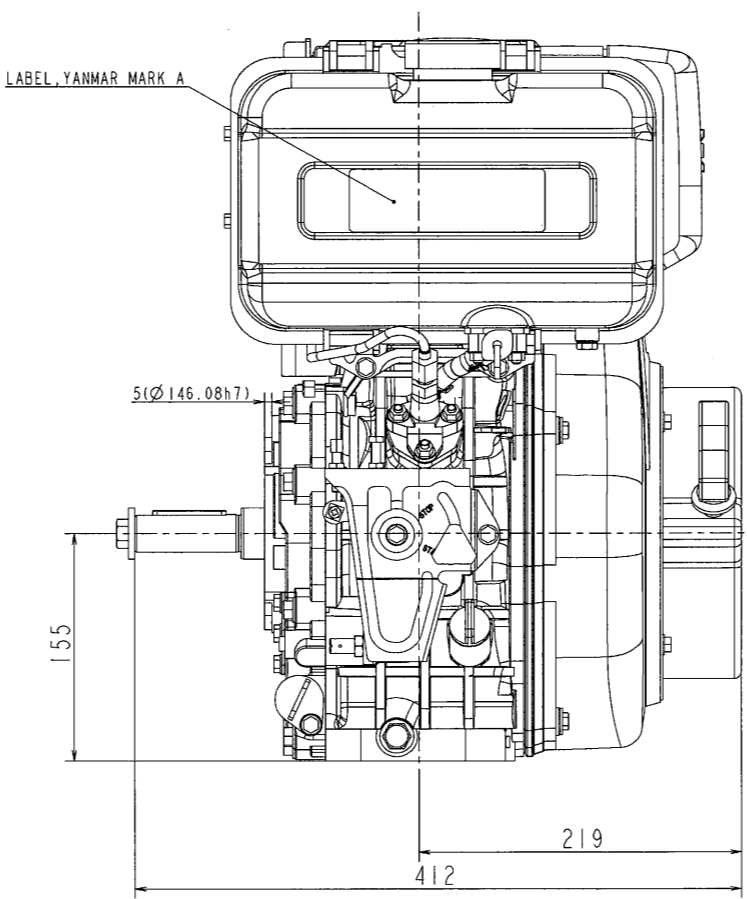
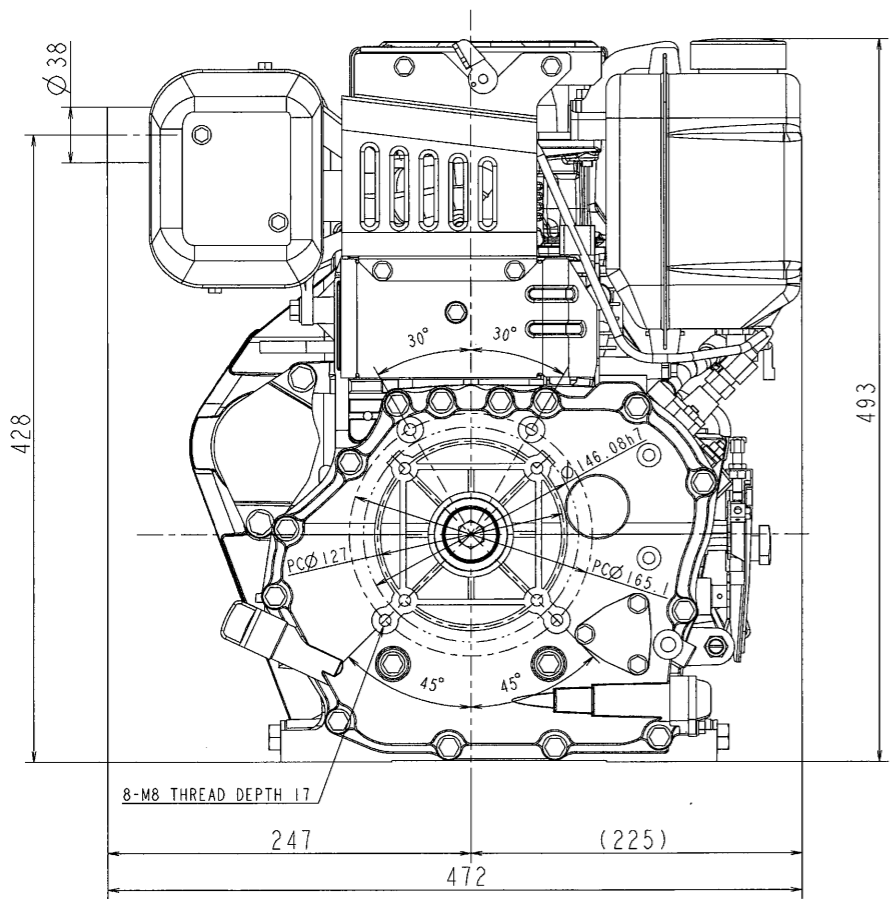

WEIGHT (RAW)	kg (± X)	SEC. MANAGER	MODEL	SCALE	FREE
WEIGHT (CALC.)	kg (± X)	J. SAMO		MATERIAL	
CHECKED	SPECIALIST	QTY	OUTLINE		
DESIGNED	DRAWN	DATE: Y. M. D. NAME	L10N6CFITIAA OUTLINE		
S. NISHIMURA	H. OGAWA	10 JAN. 2006			
YANMAR			CODE	B2-14320-0060	DRAW SIZE A1
YANMAR CO., LTD. ENGINE PRODUCT OPERATIONS DIV.					

3D-CAD	NOTICE
GEOMETRICAL TOLERANCE	SYMBOL
FORM	SYMBOL
ORIENTATION	SYMBOL
LOCATION	SYMBOL

LABELS

G2-14220-2010

No.	L A B E L S	P L A C E	C O N T E N T S
1	LABEL, ENGINE NAME	COVER (CYLINDER	_____
2	LABEL, YANMAR MARK (A	F. O. TANK	THE FOLLOWING DETAILS
3	LABEL, CAUTION	F. O. TANK	//
4	LABEL, HOW TO START	F. O. TANK	//
5	LABEL, YANMAR MARK (B	FANCASE, COOLING	//
6	LABEL, DIESEL	RECOIL STARTER	//
7	LABEL, DECOMP	COVER, TOP	//

② LABEL, YANMAR MARK (A



⑤ LABEL, YANMAR MARK (B



③ LABEL, CAUTION

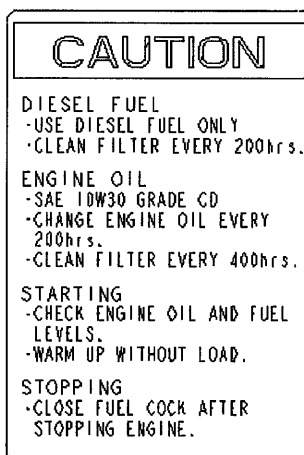

⑥ LABEL, DIESEL

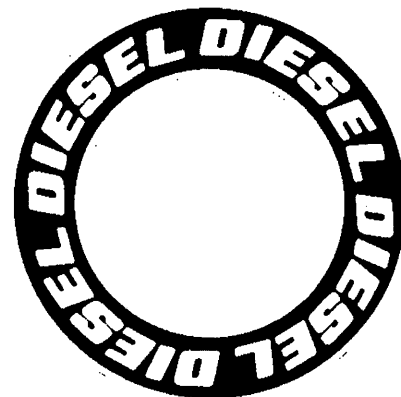

④ LABEL, HOW TO START

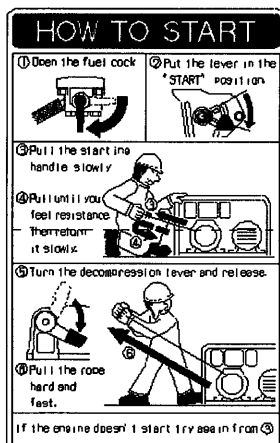

⑦ LABEL, DECOMP

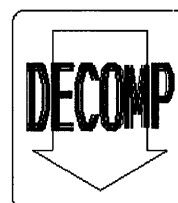

標準工具 TOOLS

C2-14110-0010

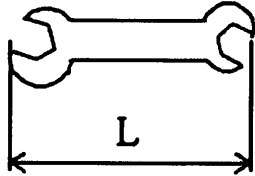
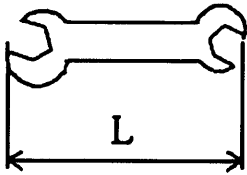
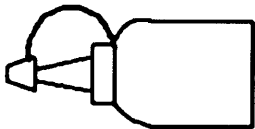
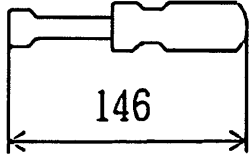
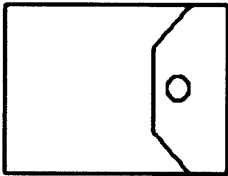
区分 ITEM	名称 DESCRIPTION	部品コード及び略図 PART NUMBER	材質 MATERIAL	個数 Q'ty	備考 NOTES
工 具	1 両口スパナ WRENCH 14×17	114299-92720 	UNI EN 10083/1 C40	1	L=163
	2 両口スパナ WRENCH 10×12	114299-92710 	UNI EN 10083/1 C40	1	L=128
	3 油さし FEEDER, OIL	114299-92740 	合成樹脂 POLYETHYRENE	1	
	4 +-ねじまわし SCREWDRIVER	114299-92730 	UNI EN 10083/1 C40 & 合成樹脂 PVC	1	
	5 工具袋 BAG, TOOL	114299-92600 	黒色ビニール PVC	1	