

# PARTS LIST

## BACKPACK BLOWER

# EBZ8001

**NOTE :**

1. Use ZENOAH genuine parts specified in the parts list for repair and/or replacement.
2. ZENOAH does not warrant the machines, those which have been damaged by the use of any parts other than those specified by the company.
3. When placing orders of parts for repair and/or replacement, check if the model name and the serial number are suitable to those specified in the parts list, then use parts number described in the parts list.
4. The contents described in the parts list may change due to improvement.
5. The parts for the machine shall be supplied within ten (10) years after the machine is discontinued.  
[It is possible that some specific parts may be subject to change of their delivery term and list price within the limit of ten (10) years after the machine is discontinued. And it is also possible that some parts may be available even after the limit of ten (10) years.]

Fig.1 BLOWER GROUP

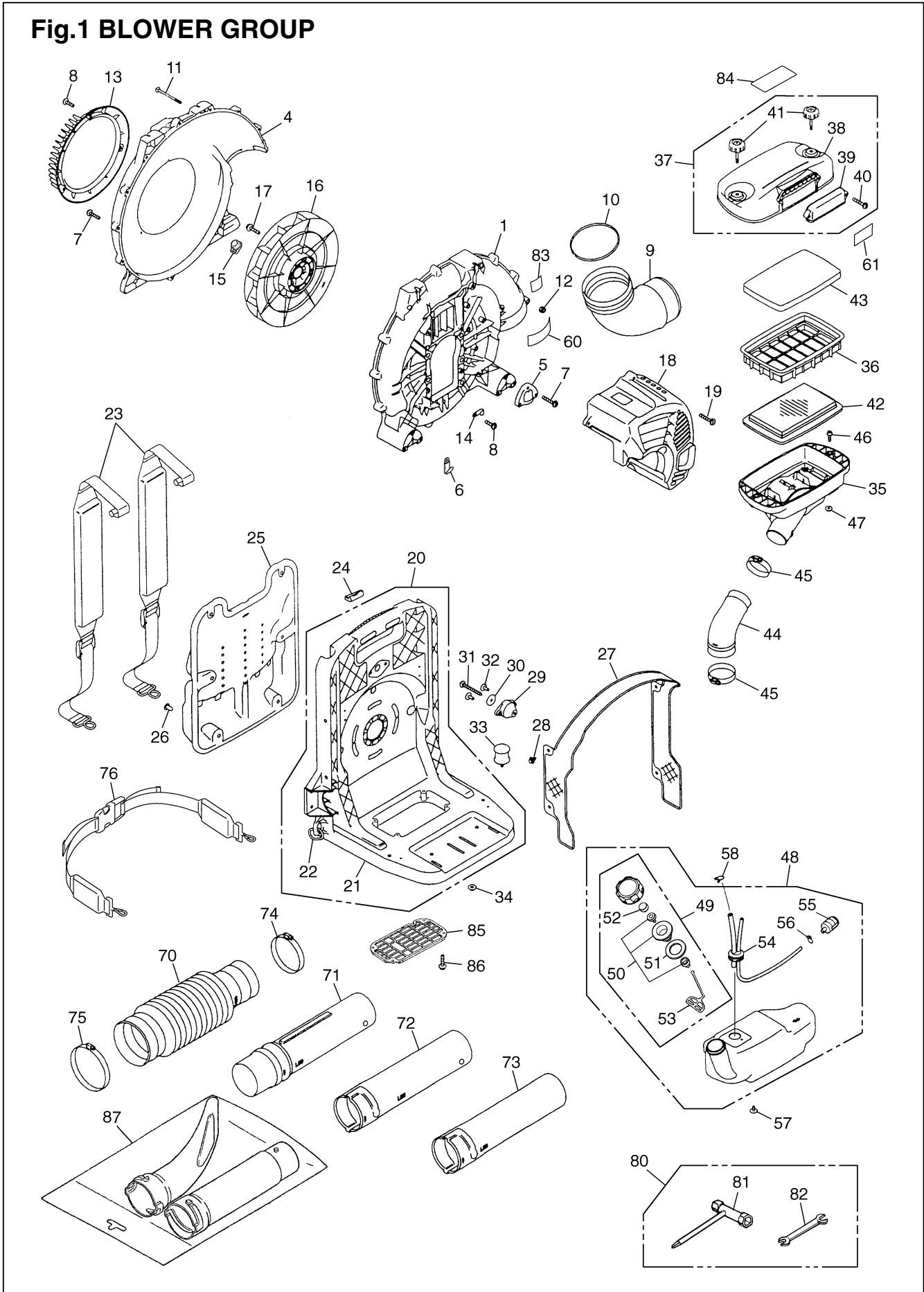

**Fig.1 BLOWER GROUP**

Key#	PART NUMBER	DESCRIPTION	Q'TY /UNIT	NOTE	Key#	PART NUMBER	DESCRIPTION	Q'TY /UNIT	NOTE
1	848L5855A4	VOLUTE CASE	1		54	848L588530	• PIPE COMP.	1	
					55	3302-85400	• FILTER	1	
4	848L5855Z0	VOLUTE COVER	1		56	1260-85460	• CLIP	1	
5	848L5855G0	BRACKET	2		57	T4960-51231	SCREW TORX	3	
6	2750-72230	CLAMP	1		58	1950-86120	CLIP	1	
7	T4970-52510	SCREW TORX	17						
8	T4970-51410	SCREW TORX	4		60	3436-91170	LABEL, CAUTION	1	
9	848L5855C2	ELBOW	1		61	848L5890R0	LABEL, EBZ8001	1	
10	07000-12100	O-RING	1						
11	T4960-57030	SCREW TORX	2		70	848L5865A1	HOSE	1	
12	3310-53331	NUT	2		71	848L586510	SWIVEL JOINT	1	
13	848L5855D4	COVER INLET	1		72	848L5865D0	PIPE, STRAIGHT	1	
14	8488K40010	CLAMP	1		73	848L5865E0	PIPE, END	1	
15	848L5855J0	CAP	1		74	8488K40020	CLAMP	1	
16	848L5952A0	FAN COMP.	1		75	8488K40030	CLAMP	1	
17	T4950-63031	BOLT TORX	4		76	848L583621	BAND ASSY	1	
18	848L5831A3	ENGINE COVER	1						
19	T4970-52510	SCREW TORX	4		80	8488U00020	TOOL-SET	1	
20	848L583514	FRAME COMP.	1		81	3540-91120	• SPANNER	1	
21	-	• FRAME	1		82	8488U10020	• SOCKET	1	
22	3490-21121	• RING	2		83	T2990-21120	LABEL (112dB)	1	
23	848L5Z3610	BAND ASSY	2		84	848L5A90W0	LABEL	1	
24	848L5836C1	CLIP	2		85	848L5835S0	NET	1	
25	848L5835C2	PAD	1		86	T4970-51410	SCREW	4	
26	3495-21320	CLIP	6		87	848L740001	FLAT NOZZLE SET		ACC
27	848L583521	NET COMP.	1						
28	1480-74710	CLIP	4						
29	2750-32510	DAMPER	1						
30	8488705040	WASHER	1						
31	8488154000	BOLT TORX	1						
32	T4960-51631	SCREW TORX	2						
33	2750-32610	DAMPER	2						
34	2750-32620	NUT (M6)	2						
35	848L5883A2	BODY, CLEANER	1						
36	848L5883U2	CASE, INNER	1						
37	848L588322	COVER ASSY	1						
38	-	• COVER	1						
39	T4012-82220	• COVER	1						
40	T4970-52510	• SCREW TORX	2						
41	848L5883J1	• KNOB BOLT	2						
42	T4012-82311	ELEMENT	1						
43	T4012-82321	ELEMENT	1						
44	848L5883P2	HOSE	1						
45	8488K40000	CLAMP	2						
46	T4950-52030	BOLT TORX	4						
47	8488645000	NUT	4						
48	848L588511	TANK ASSY	1						
49	T1015-85202	• CAP ASSY	1						
50	4500-85300	•• HOLDER ASSY	1						
51	4500-85220	•• PACKING	1						
52	5601-85260	•• FILTER	1						
53	4820-85260	•• STOPPER	1						

Fig.2 ENGINE GROUP

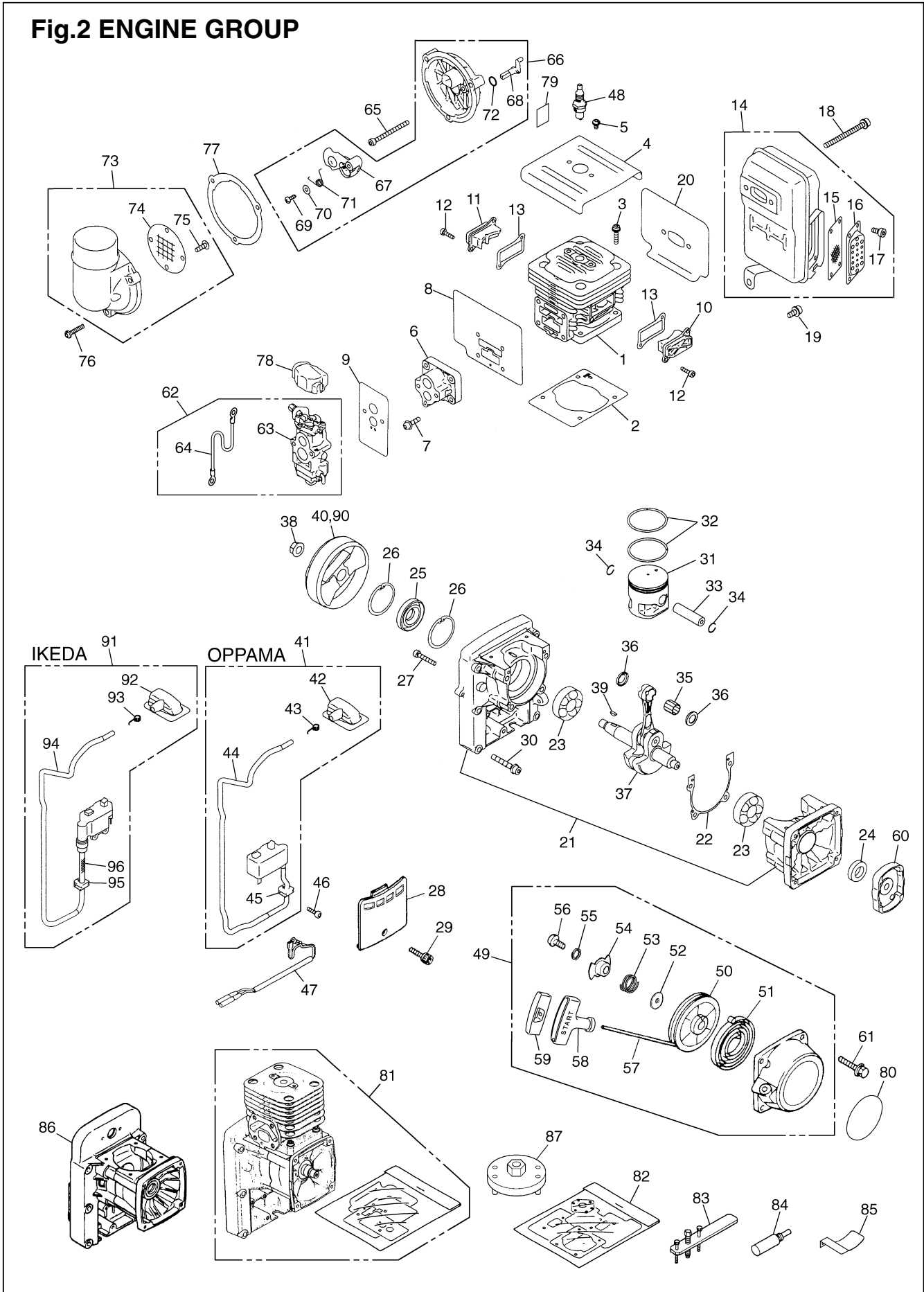

**Fig.2 ENGINE GROUP**

Key#	PART NUMBER	DESCRIPTION	Q'TY /UNIT	NOTE	Key#	PART NUMBER	DESCRIPTION	Q'TY /UNIT	NOTE
1	848H0012A3	CYLINDER	1		53	848H0075L2	• SPRING FRICTION	1	
2	848H0012B1	GASKET, BASE	1		54	848H0075K2	• PLATE FRICTION	1	
3	4820-12130	BOLT TORX	4		55	848H0075W1	• WASHER	1	
4	848H0012G0	PLATE, CYL	1		56	4500-75150	• SCREW	1	
5	T4960-50810	SCREW TORX	2		57	8488S90000	• ROPE	1	
6	848H0014A1	INSULATOR	1		58	848H0075J0	• KNOB	1	
7	8488152002	BOLT TORX	4		59	848H0075Z0	• KNOB CAP	1	
8	848H0014B2	GASKET, INSU	1		60	848H007521	PULLEY ASSY	1	
9	848H0014C1	GASKET, CARB	1		61	4820-32120	BOLT TORX	4	
10	848H0012C0	COVER, TR-S	1		62	848H008000	CARBURETOR SET	1	
11	848H0012D0	COVER, TR-F	1		63	848H008100	• CARBURETOR ASSY	1	
12	4820-72150	BOLT TORX	4		64	8488M10550	• CORD	1	
13	848H0012E1	GASKET TR	2		65	4820-82310	BOLT TORX	2	
14	848H101510	MUFFLER ASSY	1		66	848H018331	CUP ASSY	1	
15	848H1015B0	• ARRESTER	1		67	848H0183C0	• PLATE, CHOKE	1	
16	848H1015U0	• DIFFUSER	1		68	848H0183D0	• LEVER	1	
17	T4950-40800	• BOLT	4		69	8488541600	• SCREW	1	
18	T4950-67031	BOLT TORX	2		70	8488704000	• WASHER	1	
19	T4950-61431	BOLT TORX	1		71	848H0084A0	• SPRING	1	
20	848H0015C2	GASKET, MUFFLER	1		72	07000-11007	• O-RING	1	
21	848H002110	CRANKCASE COMP.	1		73	848H008341	COVER ASSY	1	
22	848H0021D1	GASKET, CASE	1		74	848H0083K1	• SCREEN	1	
23	84889G4200	BEARING	2		75	1491-82360	• SCREW	2	
24	8488AG2700	SEAL	1		76	T4970-52510	SCREW TORX	3	
25	8488AG4200	SEAL	1		77	848H0083M1	GASKET, CUP	1	
26	04065-04218	SNAP RING	2		78	4500-81910	COVER	1	
27	4820-21310	BOLT TORX	4		79	T1108-82061	LABEL, CHOKE	1	
28	848H0021H0	COVER	1		80	848L5A90C0	LABEL, RECOIL	1	
29	4820-72150	BOLT TORX	1		81	577 91 15 01	SHORT BLOCK	1	
30	8488164500	BOLT TORX	6			848H0014B2	• GASKET (#8)	1	
31	848H0041A1	PISTON	1			848H0014C1	• GASKET (#9)	1	
32	8488C50200	RING	2			848H0015C2	• GASKET (#20)	1	
33	8488BC4500	PIN	1		82	848H000610	GASKET KIT (#2,8,9,& 20)	1	
34	8488T31300	SNAP RING	2		83	2750-96100	PULLER ASSY	1	
35	84888C1600	BEARING	1		84	4810-96220	STOPPER	1	
36	848873C000	WASHER	2		85	2750-96240	GAUGE	1	
37	848H004203	CRANKSHAFT COMP.	1		86	848H002100	CASE ASSY	1	
38	1400-43230	NUT	1				(#21,22,23,24,25 26 & 27)		
39	1000-43240	KEY	1		87	8488W00020	PULLER	1	
*40	848H1071A0	ROTOR * OPPAMA	1	~#91210970					
*41	848H107121	COIL ASSY * OPPAMA	1	~#91210970	**90	574 81 42-01	ROTOR ** IKEDA	1	#91210971~
42	T1108-72110	• CAP	1		**91	574 81 43-01	COIL ASSY ** IKEDA	1	#91210971~
43	T1108-72120	• SPRING	1		92	T1108-72110	• CAP	1	
44	T1108-72130	• TUBE (PVC; Black)	1		93	5500-72120	• SPRING	1	
45	5500-72130	• GROMMET	1		94	T1108-72130	• TUBE (PVC; Black)	1	
46	4820-72150	BOLT TORX	2		95	5500-72130	• GROMMET	1	
47	T1108-71240	CORD COMP.	1		96	574 81 85-01	• TUBE (GLASS; White)	1	
48	3699-91867	SPARKPLUG NGK CMR7H	1				** IKEDA ONLY		
49	848H007512	RECOIL ASSY	1						
50	848H0075C2	• REEL	1						
51	848H0075B0	• SPRING	1						
52	848H0075M1	• WASHER	1						

\*: OPPAMA ROTOR & COIL: ~#91210970 (Engine)

\*\* : IKEDA ROTOR & COIL: #91210971~ (Engine)

**Fig.3 CARBURETOR COMPONENTS**

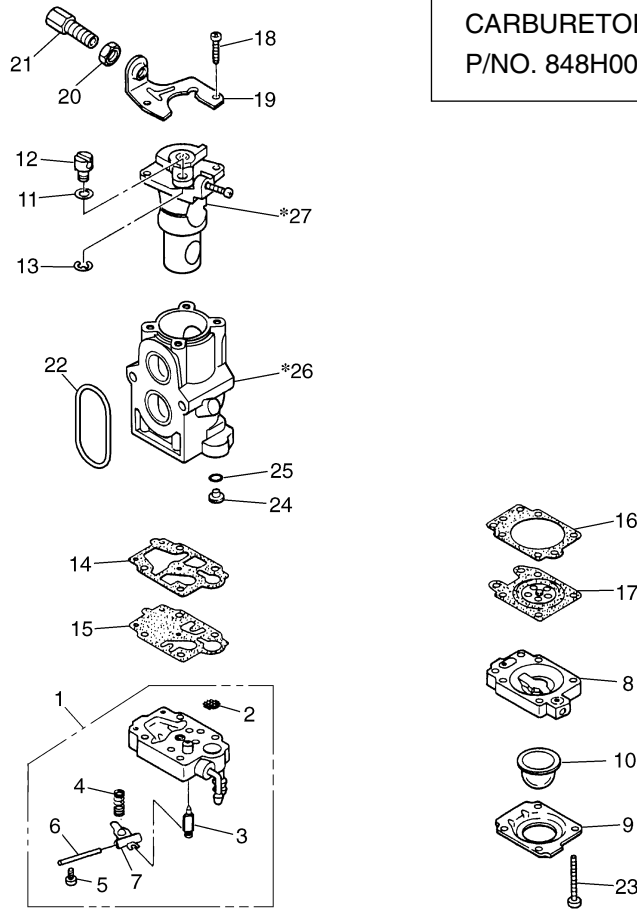

Key#	PART NUMBER	DESCRIPTION	Q'TY /UNIT	NOTE	Key#	PART NUMBER	DESCRIPTION	Q'TY /UNIT	NOTE
1	T1108-81450	Body assy	1		19	5500-81120	Bracket	1	
2	-	Screen	1		20	1751-81180	Nut	1	
3	-	Valve	1		21	1918-81170	Screw	1	
4	-	Spring	1		22	848H0080A0	Ring, packing	1	
5	-	Screw	1		23	1850-81530	Screw	4	
6	-	Pin	1		24	2750-81250	Jet #59.0	1	
7	-	Lever	1		25	1751-81240	O-Ring	1	
8	1850-81490	Body	1		*26	-	Body	1	
9	1850-81520	Cover	1		*27	-	Valve assy	1	
10	1751-81510	Pump	1						
11	5500-81160	Washer	1						
12	1881-81140	Swivel	1						
13	1751-81130	Ring	1						
14	4810-81410	Gasket	1						
15	1065-81420	Diaphragm	1						
16	1850-81470	Gasket	1						
17	4810-81260	Diaphragm	1						
18	1752-81110	Screw	2						

[NOTE]  
 \*26-BODY and \*27-VALVE ASSY are not supplied as an individual part respectively, but supplied as a CARBURETOR ASSY (P/NO. 848H008100).

**Fig.4 LEVER SET**

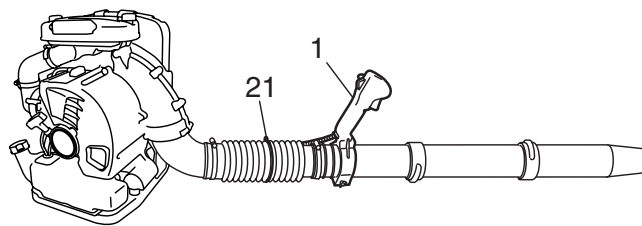
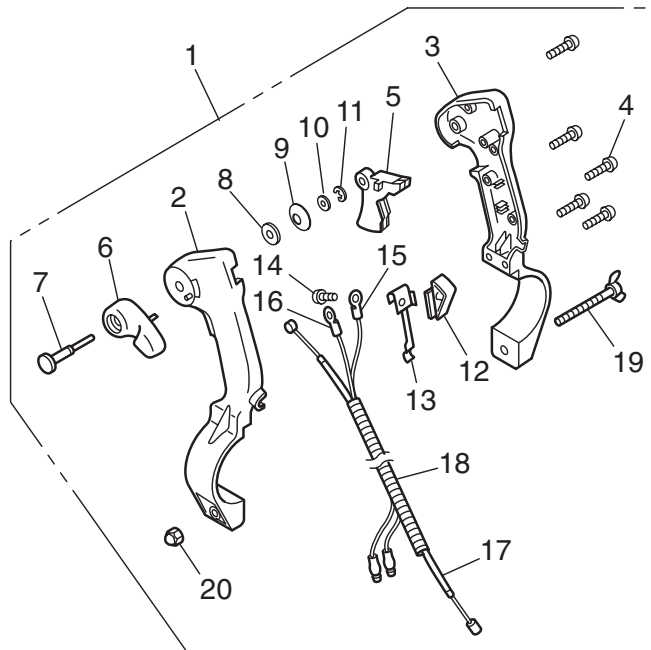

Key#	PART NUMBER	DESCRIPTION	Q'TY /UNIT	NOTE	Key#	PART NUMBER	DESCRIPTION	Q'TY /UNIT	NOTE
1	848L5A3410	LEVER SET	1		19	3495-51420	• WING BOLT	1	
2	848L5934A0	• CASE	1		20	2750-51540	• NUT	1	
3	848L5934B0	• COVER	1		21	848L5965G0	CLAMP	1	
4	T4023-25310	• SCREW 4x14	5						
5	T4023-25410	• LEVER, throttle	1						
6	848L5434D1	• LEVER	1						
7	T4023-25440	• SHAFT	1						
8	T4023-25450	• WASHER	1						
9	T4023-25460	• SPRING WASHER	1						
10	3238-15230	• WASHER	1						
11	T4023-25480	• CLIP	1						
12	T4023-25710	• SWITCH	1						
13	T4023-25721	• SPRING	1						
14	T4023-25730	• SCREW 4x10	1						
15	T4023-25740	• CORD	1						
16	T4023-25750	• CORD	1						
17	8488P30390	• CABLE	1						
18	8488H19402	• TUBE	1						