

PARTS LIST

RECIPROCATORS

SGCZ2610DL
SGCZ2610DW

NOTE :

1. Use ZENOAH genuine parts as specified in the parts list for repair and/or replacement.
2. ZENOAH does not warrant the machines, which have been damaged by the use of any parts other than those specified by the company.
3. When placing parts orders for repair and/or replacement, check if the model name and the serial number are applicable to those specified in the parts list, then use parts number described in the parts list.
4. The contents described in the parts list are accurate as of the date and may change due to improvement.
5. The parts for the machine shall be supplied ten (10) years after the machine is discontinued. [It is possible that some specific parts may be subject to change of their delivery term and list price within the limit of ten (10) years after the machine is discontinued. It is also possible that some parts may be available even after the limit of ten (10) years.]

APPLICABLE SERIAL NUMBERS:

SGCZ2610DL : 80200001 and up
SGCZ2610DW : 80200001 and up

May 2008

Fig.1 DRIVE UNIT

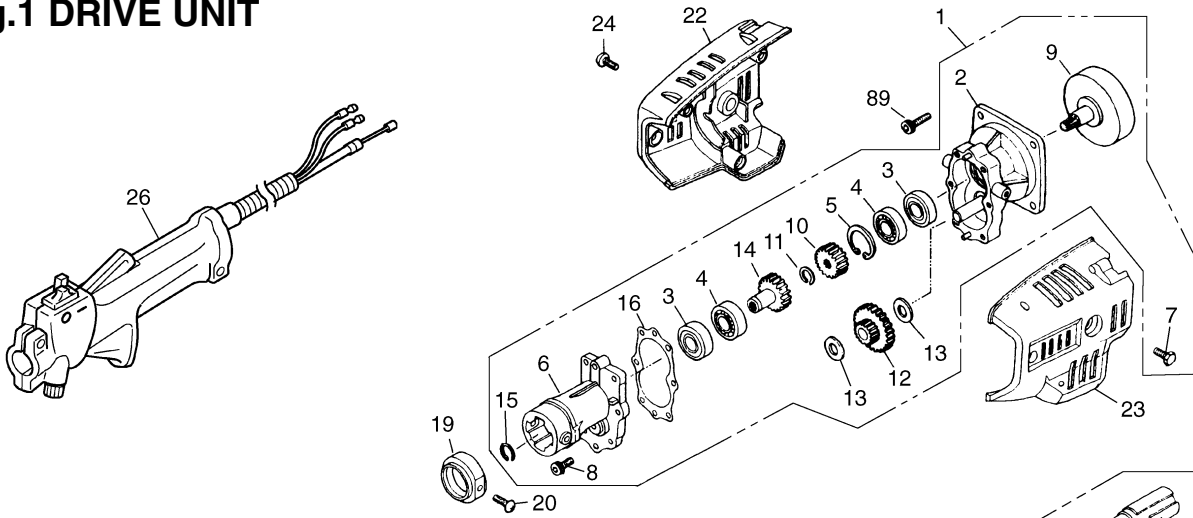

Fig.2 CASE UNIT

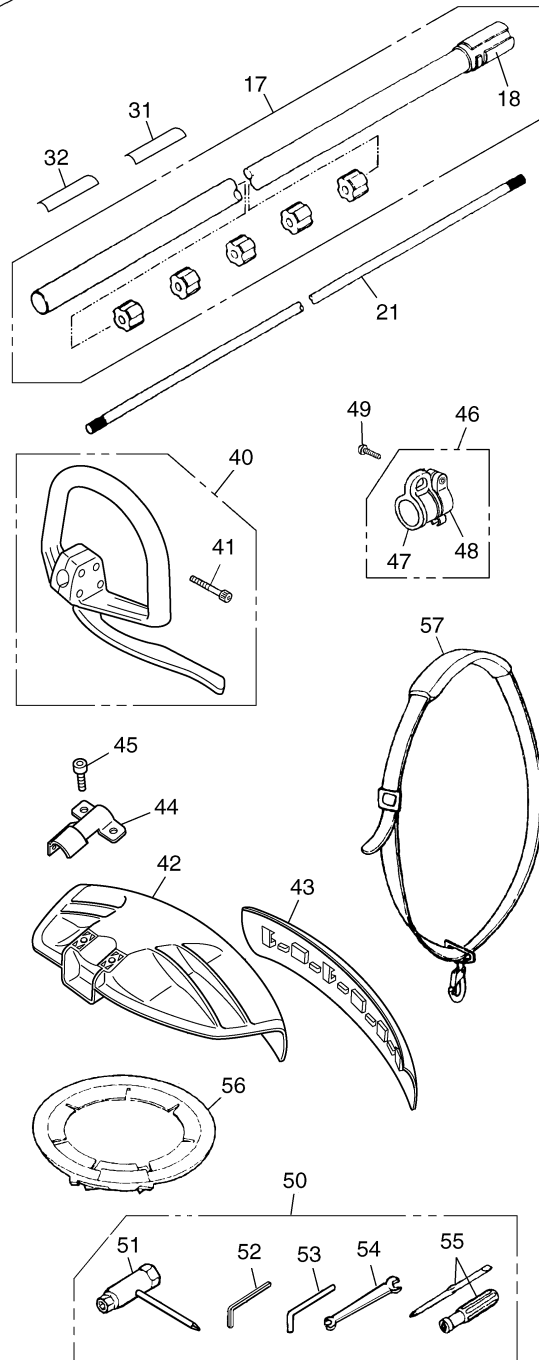
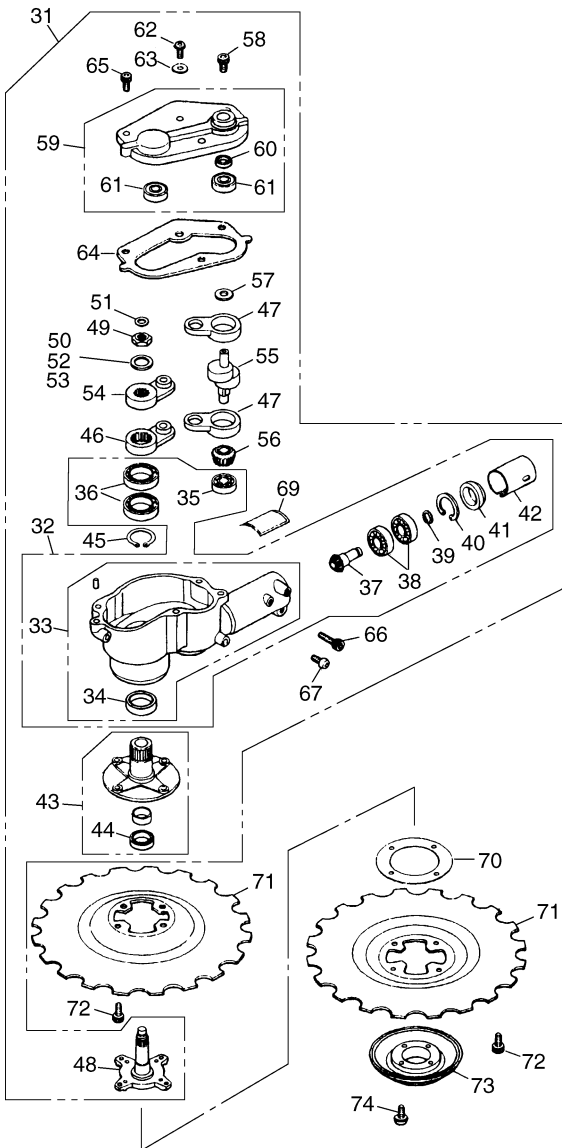

Fig.1 DRIVE UNIT

Key#	PART NUMBER	DESCRIPTION	Q'TY /UNIT	NOTE	Key#	PART NUMBER	DESCRIPTION	Q'TY /UNIT	NOTE
1	T3065-11000	MISSION ASSY	1		44	848JN366C0	BRACKET	1	
2	3805-11102	• CASE COMP, rear	1		45	T4950-63040	BOLT TORX	2	M6x30
3	06002-06001	• BEARING	2		46	T3300-17202	HANGER ASSY	1	
4	06000-06001	• BEARING	2		47	T3300-17212	• HANGER	1	
5	04065-02812	• RING	1		48	T3300-17222	• CLAMP	1	
6	3805-11211	• CASE, front	1		49	8488052000	SCREW	1	
7	0225-00608	• BOLT	2		50	8488U00170	TOOL SET	1	
8	01252-30520	• BOLT	6		51	T4017-91130	• SOKET	1	
9	3805-11310	• DRUM	1		52	09007-00425	• WRENCH	1	
10	3805-11320	• GEAR, pinion	1		53	09007-00528	• WRENCH	1	
11	3180-13330	• RING	1		54	3540-91120	• SPANNER	1	
12	3805-11331	• GEAR, idler	1		55	1030-91340	• DRIVER	1	
13	2850-55211	• WASHER	2		56	848JL092B1	COVER	1	
14	3805-11360	• GEAR, wheel	1		57	848J823610	STRAP ASSY	1	
15	3130-13270	• RING	1						
16	3805-11412	• GASKET	1		89	T4950-62040	BOLT	4	
17	3805-12101	PIPE COMP.	1						
18	3805-12131	• CUSHION	1	*					
19	3565-11341	CAP	1						
20	0263-90510	SCREW	2						
21	3805-12210	SHAFT	1						
22	3805-11511	COVER, right	1						
23	3805-11521	COVER, left	1						
24	2200-76210	SCREW	3						
26	T3101-11330	GRIP ASS'Y	1						
31	848JN590R0	PLATE, name	1						
32	848JN590X0	LABEL	1						
40	T3110-14000	HANDLE ASSY	1						
41	0263-90530	• SCREW	4						
42	848JL066A4	GUARD	1						
43	848JN366E0	GUARD	1						

Fig.2 CASE UNIT

Key#	PART NUMBER	DESCRIPTION	Q'TY /UNIT	NOTE	Key#	PART NUMBER	DESCRIPTION	Q'TY /UNIT	NOTE
31	848JN36110	CASE ASSY	1		57	01641-20812	• WASHER	1	
32	3974-98102	• CASE COMP, cutter	1		58	3805-13750	• BOLT	1	
33	3974-13102	•• CASE COMP, cutter	1		59	T3065-13800	• COVER COMP.	1	
34	3805-13130	••• SEAL	1		60	3805-13840	•• SEAL	1	
35	06000-00608	•• BEARING	1		61	06000-00608	•• BEARING	2	
36	06000-06804	•• BEARING	2		62	0263-00610	• SCREW	1	
37	3805-13930	•• PINION	1		63	01642-20608	• WASHER	1	
38	06000-06000	•• BEARING	2		64	3805-13910	• GASKET	1	
39	3180-13330	•• RING	1		65	01252-40520	• BOLT	3	
40	04065-02612	•• RING	1		66	01010-50635	• BOLT	1	
41	3805-13940	•• PACKING	1		67	01252-70514	• SCREW	1	
42	3805-13951	•• SPACER	1						
43	3805-13200	• SHAFT COMP.	1		69	3975-13990	• LABEL	1	
44	3805-13230	•• SEAL	1		70	3805-13590	SHIM	1	
45	04064-02012	• RING	1		71	8488Z07051	BLADE	2	
46	3805-13412	• ARM, lower	1		72	01252-40608	BOLT	8	
47	8488R261M3	• CONROD	2		73	3805-15140	STABILIZER	1	
48	3805-13510	• SHAFT, inner	1		74	0263-30508	SCREW	4	
49	3805-13520	• NUT	1						
50	3805-13550	• SHIM, 0.3t	0~1						
51	3805-13560	• SHIM	1						
52	3805-13570	• SHIM, 0.2t	0~1						
53	3805-13580	• SHIM, 0.1t	0~1						
54	3805-13612	• ARM, upper	1						
55	3805-13711	• CRANKSHAFT	1						
56	3805-13720	• GEAR	1						

* Use Threebond 1521 for adhesion.

Fig.3 DRIVE UNIT

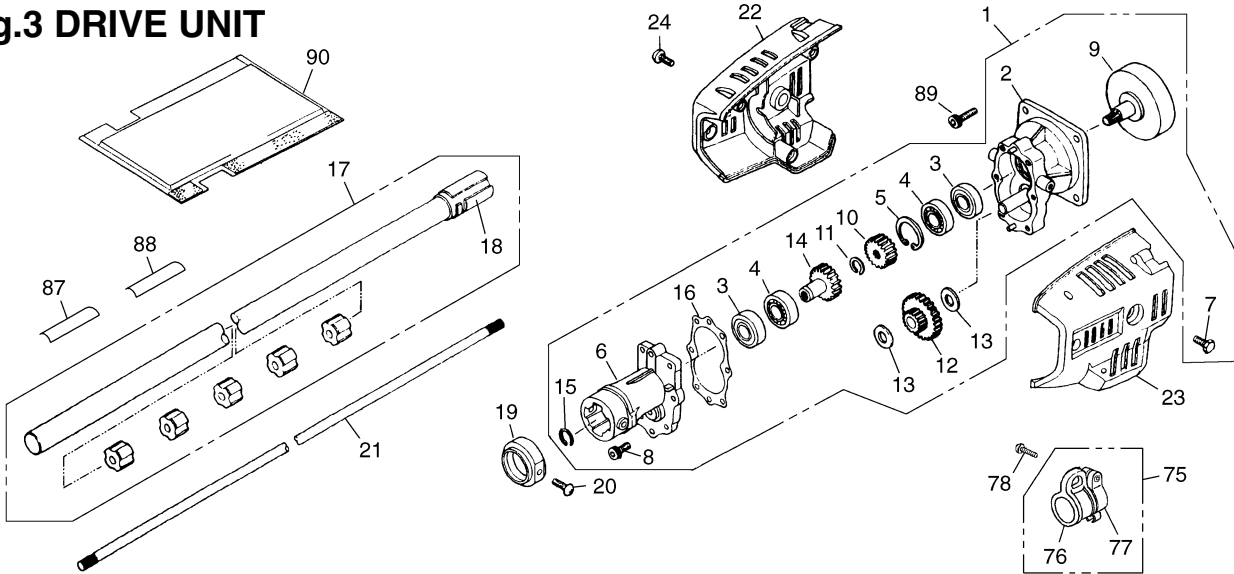

Fig.4 CASE UNIT

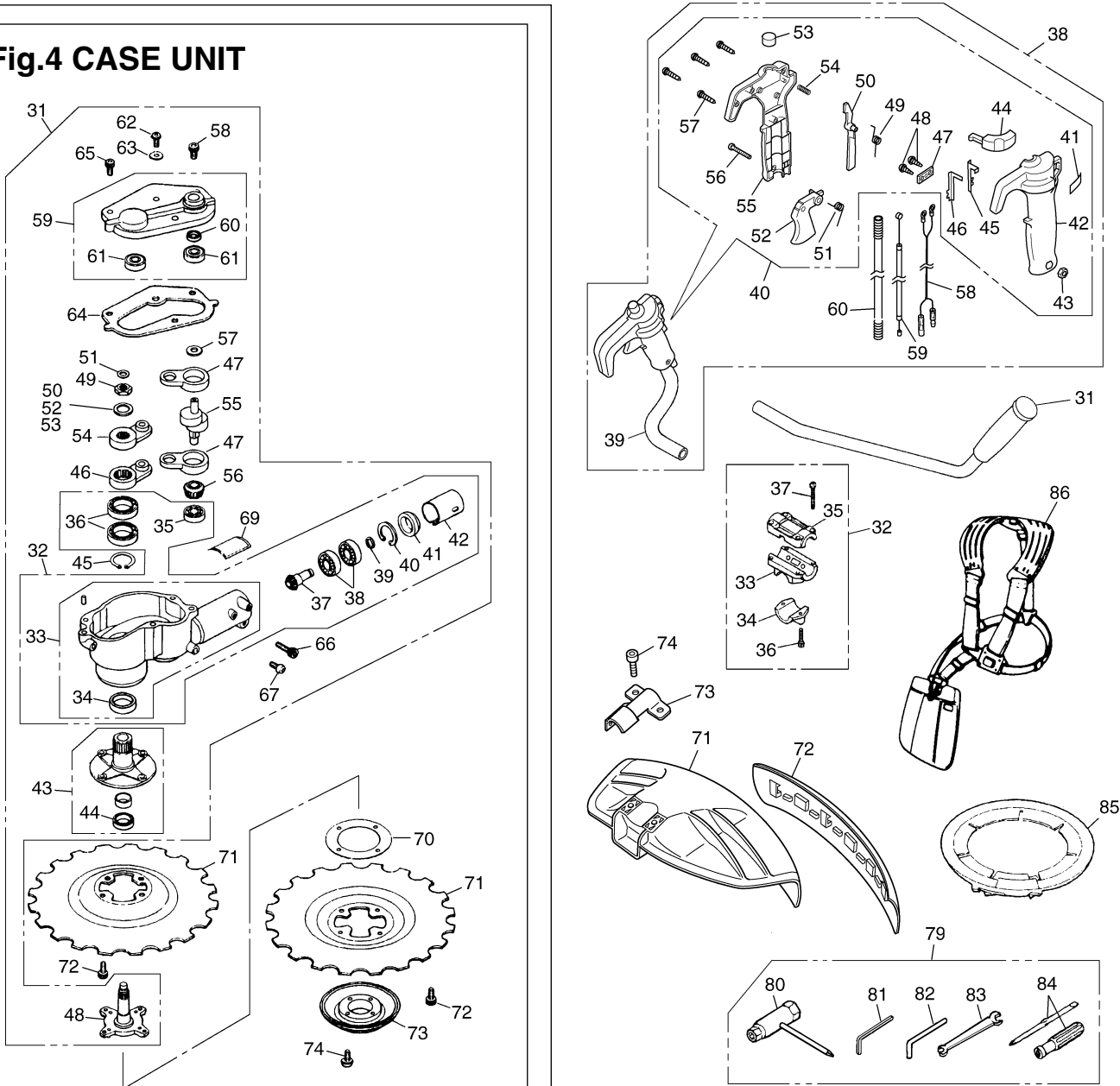

Fig.3 DRIVE UNIT

Key#	PART NUMBER	DESCRIPTION	Q'TY /UNIT	NOTE	Key#	PART NUMBER	DESCRIPTION	Q'TY /UNIT	NOTE
1	T3065-11000	MISSION ASSY	1		44	K2300-000080	•• SWITCH	1	
2	3805-11102	• CASE COMP, rear	1		45	K5100-000030	•• SPRING	1	
3	06002-06001	• BEARING	2		46	K5100-000040	•• SPRING	1	
4	06000-06001	• BEARING	2		47	K2300-000090	•• HOLDER	1	
5	04065-02812	• RING	1		48	B1122-C2910H	•• SCREW, tapping	2	M3x10
6	3805-11211	• CASE, front	1		49	K5100-000020	•• SPRING	1	
7	0225-00608	• BOLT	2		50	K2300-000070	•• LEVER	1	
8	01252-30520	• BOLT	6		51	K5100-000010	•• SPRING	1	
9	3805-11310	• DRUM	1		52	K2300-000060	•• LEVER	1	
10	3805-11320	• GEAR, pinion	1		53	K1300-000060	•• PLUG	1	
11	3180-13330	• RING	1		54	K5100-000050	•• SPRING	1	
12	3805-11331	• GEAR, idler	1		55	K2300-000040	•• GRIP (R)	1	
13	2850-55211	• WASHER	2		56	B1111-A0530H	•• SCREW	1	M5x30
14	3805-11360	• GEAR, wheel	1		57	B1122-C4220H	•• SCREW, tapping	5	M4x20
15	3130-13270	• RING	1		58	K5200-000060	• CORD	1	
16	3805-11412	• GASKET	1		59	K5100-000130	• CABLE	1	
17	3805-12101	PIPE COMP.	1		60	K5200-000080	• TUBE	1	
18	3805-12131	• CUSHION	1	*	71	848JL066A4	GUARD	1	
19	3565-11341	CAP	1		72	848JN366E0	GUARD	1	
20	0263-90510	SCREW	2		73	848JN366C0	BRACKET	1	
21	3805-12210	SHAFT	1		74	T4950-63040	BOLT TORX	2	M6x30
22	3805-11511	COVER, right	1		75	T3300-17202	HANGER ASSY	1	
23	3805-11521	COVER, left	1		76	T3300-17212	• HANGER	1	
24	2200-76210	SCREW	3		77	T3300-17222	• CLAMP	1	
31	T3111-14300	HANDLE-L COMP.	1		78	8488052000	SCREW	1	
32	848JC13230	BRACKET ASSY	1		79	8488U00170	TOOL SET	1	
33	3583-14111	• BRACKET	1		80	T4017-91130	• SOKET	1	
34	3583-14121	• CAP-L	1		81	09007-00425	• WRENCH	1	
35	3257-14192	• CAP-U	1		82	09007-00528	• WRENCH	1	
36	4820-13180	• BOLT	2		83	3540-91120	• SPANNER	1	
37	T4950-52500	• BOLT	4		84	1030-91340	• DRIVER	1	
38	T3111-14001	HANDLE-R ASSY	1		85	848JL092B1	COVER	1	
39	T3111-14310	• HANDLE-R	1		86	6220-17202	HARNES ASSY	1	
40	K6010-000550	• GRIP&LEV COMP.	1		87	8488X10020	LABEL	1	
41	K2200-000040	•• LABEL	1		88	848JN590R0	PLATE, name	1	
42	K2300-000050	•• GRIP (L)	1		89	T4950-62040	BOLT	4	
43	B1181-040545	•• NUT	1		90	848B8138A1	PROTECTOR	1	

Fig.4 CASE UNIT

Key#	PART NUMBER	DESCRIPTION	Q'TY /UNIT	NOTE	Key#	PART NUMBER	DESCRIPTION	Q'TY /UNIT	NOTE
31	848JN36110	CASE ASSY	1		54	3805-13612	• ARM, upper	1	
32	3974-98102	• CASE COMP, cutter	1		55	3805-13711	• CRANKSHAFT	1	
33	3805-13123	•• CASE COMP, cutter	1		56	3805-13720	• GEAR	1	
34	3805-13130	••• SEAL	1		57	01641-20812	• WASHER	1	
35	06000-00608	•• BEARING	1		58	3805-13750	• BOLT	1	
36	06000-06804	•• BEARING	2		59	T3065-13800	• COVER COMP.	1	
37	3805-13930	•• PINION	1		60	3805-13840	•• SEAL	1	
38	06000-06000	•• BEARING	2		61	06000-00608	•• BEARING	2	
39	3180-13330	•• RING	1		62	0263-00610	• SCREW	1	
40	04065-02612	•• RING	1		63	01642-20608	• WASHER	1	
41	3805-13940	•• PACKING	1		64	3805-13910	• GASKET	1	
42	3805-13951	•• SPACER	1		65	01252-40520	• BOLT	3	
43	3805-13200	• SHAFT COMP.	1		66	01010-50635	• BOLT	1	
44	3805-13230	•• SEAL	1		67	01252-70514	• SCREW	1	
45	04064-02012	• RING	1		69	3975-13990	• LABEL	1	
46	3805-13412	• ARM, lower	1		70	3805-13590	SHIM	1	
47	8488R261M3	• CONROD	2		71	8488Z07051	BLADE	2	
48	3805-13510	• SHAFT, inner	1		72	01252-40608	BOLT	8	
49	3805-13520	• NUT	1		73	3805-15140	STABILIZER	1	
50	3805-13550	• SHIM, 0.3t	0~1		74	0263-30508	SCREW	4	
51	3805-13560	• SHIM	1						
52	3805-13570	• SHIM, 0.2t	0~1						
53	3805-13580	• SHIM, 0.1t	0~1						

* Use Threebond 1521 for adhesion.

Fig.5 ENGINE UNIT

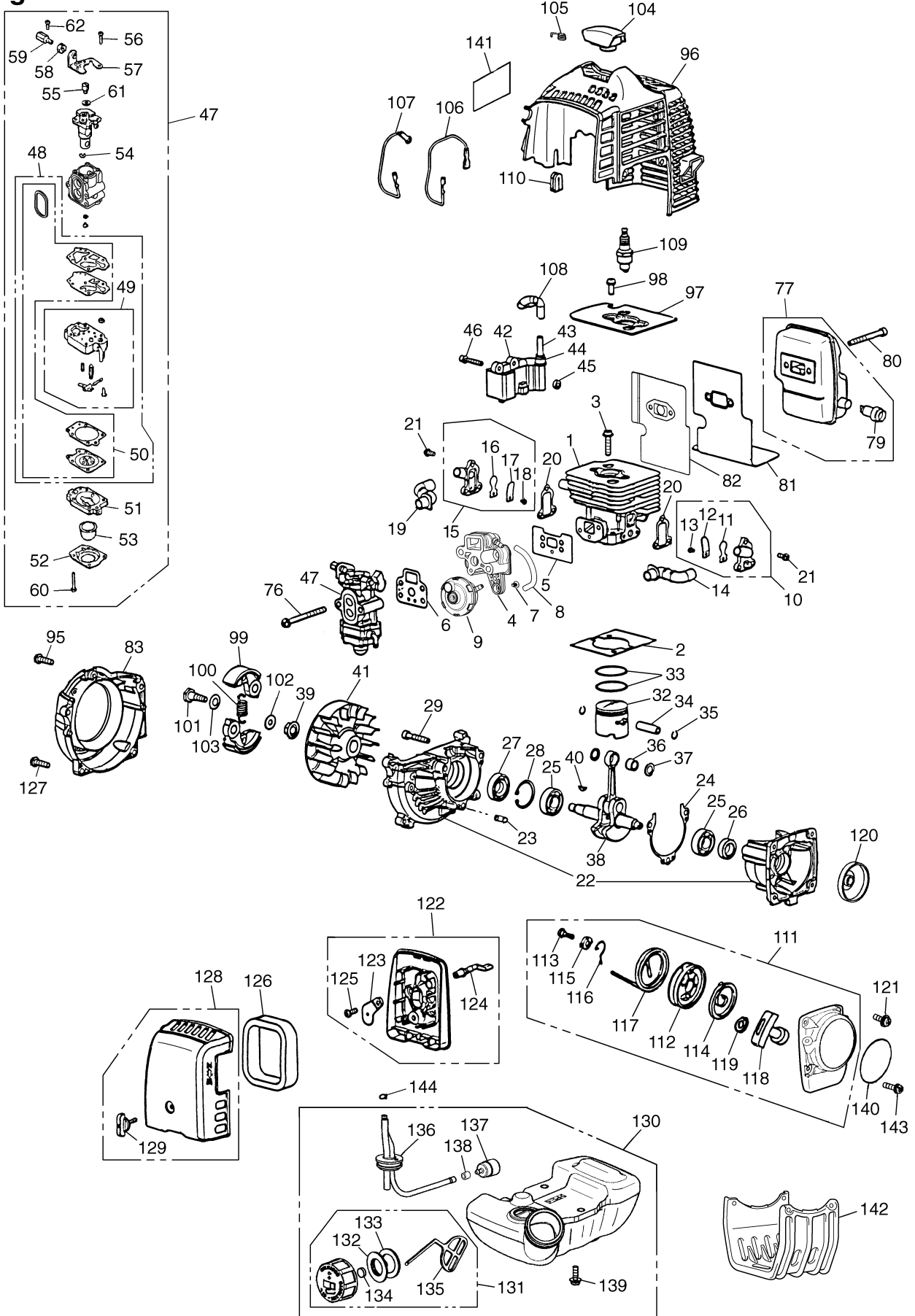

Fig.5 ENGINE UNIT

Key#	PART NUMBER	DESCRIPTION	Q'TY /UNIT	NOTE	Key#	PART NUMBER	DESCRIPTION	Q'TY /UNIT	NOTE
1	848F3R12A2	CYLINDER	1		81	848F3R15C0	GASKET	1	
2	848F3R12B0	GASKET, base	1		82	848F3R15D0	PLATE, muffler	1	
3	4820-12130	BOLT, M5x22	2		83	T1500-31110	COVER ASSY	1	
4	848F4014A0	INSULATOR	1						
5	848F4014B0	GASKET, insulator	1		95	4820-32120	SCREW, M5x16	3	
6	T1590-13130	GASKET, carburetor	1		96	848F3R31A0	COVER, engine	1	
7	8488530600	SCREW, M3x6	1		97	848F3R12G0	PLATE	1	
8	8488F40550	TUBE	1		98	4820-12350	SCREW, M5x10	2	
9	848F408801	PUMP ASSY	1		99	4820-51110	SHOE	2	
10	848F3R1601	REEDVALVE (S) ASSY	1		100	4820-51220	SPRING	1	
11	848F3R16C0	• REEDVALVE	1		101	T1500-51250	SCREW	2	
12	4810-16130	• STOPPER	1		102	T1500-51230	WASHER	2	
13	4810-16170	• SCREW, M3x8	1		103	1140-51242	WASHER	2	
14	848F3R16E0	PIRE AIR (S)	1		104	848F3071C2	CAP	1	
15	848F3R1611	REEDVALVE (F) ASSY	1		105	1900-72120	SPRING	1	
					106	4810-71240	CORD	1	
16	848F3R16C0	• REEDVALVE	1		107	4810-71250	CORD, earth	1	
17	4810-16130	• STOPPER	1		108	T1512-71320	TUBE	1	
18	4810-16170	• SCREW, M3x8	1		109	3699-91867	PLUG, NGK CMR7H	1	
19	848F3R16F0	PIPE AIR (F)	1		110	4810-72120	GROMMET	1	
20	848F3R16H0	GASKET, valve	2		111	4810-75100	RECOIL ASSY	1	
21	8488141000	SCREW	6		112	4500-75120	• REEL	1	
22	4810-21101	CRANKCASE COMP.	1		113	4500-75150	• SCREW	1	
23	2629-21130	• PIN	3		114	1850-75130	• SPRING, spiral	1	
24	4810-21140	GASKET	1		115	4500-75180	• COLLAR	1	
25	06030-06001	BEARING	2		116	4500-75190	• ARM	1	
26	4810-21210	SEAL	1		117	4810-75160	• ROPE	1	
27	1850-21220	SEAL	1		118	3330-75421	• KNOB	1	
28	04065-02812	SNAP RING	1		119	4810-75170	• PLATE, stopper	1	
29	4820-21310	BOLT, M5x30	3		120	4500-75210	PULLEY	1	
					121	T1501-32120	SCREW, M5x16	2	
32	848F4041A0	PISTON	1		122	4810-82100	BODY ASSY	1	
33	8488C34101	RING	2		123	4810-82130	• PLATE, choke	1	
34	8488B82800	PIN	1		124	5500-82140	• LEVER, choke	1	
35	1260-41320	RING	2		125	2630-33610	• SCREW	1	
36	T1551-41410	BEARING	1		126	4810-82170	ELEMENT	1	
37	8488738002	WASHER	2		127	4820-12310	BOLT, M5x22	2	
38	848F3R4200	CRANKSHAFT COMP.	1		128	848F408321	COVER ASSY	1	
39	1650-43230	NUT	1		129	5500-82221	• KNOB	1	
40	1000-43240	KEY	1		130	848F348501	TANK ASSY	1	
41	4810-71110	ROTOR	1		131	T1015-85202	• CAP ASSY	1	
42	T1512-71200	COIL ASSY	1		132	4500-85300	•• HOLDER ASSY	1	
43	T1512-71220	• CORD	1		133	4500-85220	•• PACKING	1	
44	2616-71320	• CAP	1		134	5601-85260	•• FILTER	1	
45	1260-71261	SPACER	2		135	4820-85260	•• STOPPER	1	
46	4820-72150	BOLT, M4x22	2		136	4810-85300	• PIPE COMP.	1	
47	848F4C8100	CARBURETOR ASSY	1		137	3302-85400	• FLTER ASSY	1	
48	848F600630	• REBUILD KIT	1		138	1260-85460	• CLIP	1	
49	1850-81450	•• BODY ASSY	1		139	4820-85510	SCREW, M5x16	3	
50	4810-06021	•• GASKET KIT	1		140	T1504-75411	LABEL, recoil	1	
51	848F4081G0	• BODY	1		141	848F6190B1	LABEL, cover	1	
52	1850-81520	• COVER	1		142	848F4085Z0	GUARD	1	
53	1751-81510	• PUMP	1		143	4820-12130	BOLT, M5x22	2	
54	1751-81130	• RING	1		144	1950-86120	CLIP	1	
55	1881-81140	• SWIVEL	1						
56	1752-81110	• SCREW	2						
57	5500-81120	• BRACKET	1						
58	1751-81180	• NUT	1						
59	8488361200	• SCREW	1						
60	1850-81530	• SCREW	4						
61	5500-81160	• WASHER	1						
62	8488330400	• SCREW	1						
76	4820-82310	SCREW, M5x60	2						
77	848F401510	MUFFLER ASSY	1						
79	4810-15140	• ARRESTER	1						
80	4820-15310	BOLT, M5x50	2						